

Chariot à roulettes pour îlot de cuisine
Kücheninsel-Rollwagen
Carrello scorrevole per Isola della cucina
Carro con ruedas para isla de cocina
アイランドキッチン ローリングカート
带轮中岛台

A



B



ASSEMBLY INSTRUCTION

Montageanleitung
Instructions De Montage
Istruzioni Per L'assemblaggio
Instrucciones De Montaje
組立説明書
安装说明书



HELPFUL HINTS

BEFORE YOU START

- Inspect product packaging to ensure the appearance is good.
- Read the assembly instruction carefully and follow it step by step.
- To avoid any scratching, putting a soft blanket on the floor is suggested.
- Identify, sort and count all the parts with tags.
- Find out installation position according to the drawing and install it in correct steps.

OTHER

- People needed for assembly: 1-2.
- Estimated assembly time: 0.5-1h.

CAUTION

- Be cautious when using a power drill or power screwdriver.
- Please be aware to slow down and stop when screw is nearly tight.
- Do Not use any harsh chemicals or abrasive cleaners for this item.
- Push, pull or drag this item carefully.

ASTUCES UTILES

AVANT DE COMMENCER

- Inspectez l'emballage du produit pour vous assurer que l'apparence est bonne.
- Lisez attentivement les instructions de montage et suivez-les étape par étape.
- Pour éviter toute rayure, posez une couverture douce sur le sol est suggéré.
- Identifiez, triez et comptez toutes les pièces avec des étiquettes.
- Trouver la position d'installation selon le dessin et l'installer dans les étapes correctes.

AUTRE

- Personnes nécessaires pour l'assemblage : 1-2.
- Temps de montage estimé : 0.5-1 h.

AVERTIR

- Soyez prudent lorsque vous utilisez une perceuse électrique ou un tournevis électrique.
- Veuillez être conscient de ralentir et d'arrêter lorsque la vis est presque serrée.
- N'utilisez pas de produits chimiques corrosifs ou de nettoyeurs abrasifs pour cet article.
- Poussez, tirez ou tirez cet article avec précaution.

CONSEJOS ÚTILES

ANTES DE EMPEZAR

- Inspeccione el paquete del producto para asegurarse de que la apariencia es buena.
- Lea atentamente las instrucciones de montaje y sígalas paso a paso.
- Para evitar rayas, se sugiere poner una manta suave en el suelo.
- Identifique, clasifique y enumere todas las piezas con etiquetas.
- Averigüe la posición de instalación según el dibujo e instálela en los pasos correctos.

OTROS

- Personas necesarias para el montaje: 1-2.
- Tiempo de montaje estimado: 0.5-1 h.

PRECAUCIÓN

- Tenga cuidado al utilizar un taladro eléctrico o un destornillador eléctrico.
- Tenga en cuenta que debe hacerlo más despacio y detenerse cuando el tornillo esté casi apretado.
- No utilice productos químicos agresivos ni limpiadores abrasivos para este artículo.
- Empuje, tire o arrastre este elemento con cuidado.

SUGGERIMENTI UTILI

PRIMA DI INIZIARE

- Controllare la confezione del prodotto per assicurarsi che sia in buono stato.
- Leggere con attenzione le istruzioni per l'assemblaggio e seguirle passo dopo passo.
- Per evitare graffi al pavimento, suggeriamo di stendervi una coperta morbida.
- Identificare, suddividere e contare tutte le parti con etichetta.
- Trovare la posizione adatta per il montaggio in base al disegno e montare lo scaffale seguendo correttamente i vari passaggi.

ALTRO

- Persone necessarie per l'assemblaggio: 1-2.
- Tempo di assemblaggio stimato: 0.5-1 ora.

ATTENZIONE

- Prestare molta attenzione quando si utilizza un trapano elettrico o un cacciavite elettrico.
- Rallentare con accortezza e fermarsi quando una vite è già sufficientemente serrata.
- Non utilizzare prodotti chimici aggressivi o detergenti abrasivi su questo articolo.
- Spingere, tirare o trascinare questo articolo con cautela.

NÜTZLICHE HINWEISE

⚠️ BEVOR SIE BEGINNEN

- Überprüfen Sie die Produktverpackung auf Schäden.
- Lesen Sie sich die Montageanleitung sorgfältig durch und befolgen Sie sie Schritt für Schritt.
- Um etwaiges Zerkratzen zu vermeiden, wird das Auslegen einer weichen Decke auf dem Boden empfohlen.
- Identifizieren, sortieren und zählen Sie alle Teile mit Tags nach.
- Identifizieren Sie die Montageposition gemäß der Zeichnung und bauen Sie das Regal den richtigen Schritten entsprechend auf.

SONSTIGES

- Für den Zusammenbau erforderliche Anzahl an Menschen: 1-2.
- Ungefähre Montagedauer: 0.5-1 h.

⚠️ VORSICHT

- Seien Sie bei der Verwendung einer Bohrmaschine oder eines Akkuschraubers vorsichtig.
- Bitte vergessen Sie nicht darauf, langsamer zu werden und zu stoppen, sobald die Schraube fast festgezogen ist.
- Verwenden Sie keinerlei aggressive Chemikalien oder scheuernden Reinigungsmittel für dieses Produkt.
- Schieben oder ziehen Sie dieses Produkt vorsichtig.

温馨提示

⚠️ 组立前说明

- 检查产品包装，确保外观良好。
- 仔细阅读组装说明，并按步骤操作。
- 为了避免任何刮伤，建议在地板上放一条柔软的毯子。
- 用标签识别、分类和计数所有部件。
- 根据图纸找到安装位置，按正确步骤安装。

其他:

- 组装所需人员: 1-2人。
- 预计组装时间: 0.5-1小时。

⚠️ 注意:

- 建议优先使用电动螺丝刀组装,使用电钻或电动螺丝刀时请谨慎。
- 当螺丝快要拧紧时, 请注意减速并停止。
- 不要使用任何粗糙的化学物质或研磨清洁剂。
- 小心地推、拉或拖此产品。

役に立つヒント

⚠️ 組立の場所を確保し、順番通りに組み立てる

- 組立場所（充分広くて平たい場 v 所）を確保してください。
- 床や壁、商品を傷つけないように、商品の下に厚めの布や段ボールなどを敷いてください。
- 組立の順番を守らないと、組立できなくなったり、商品を傷つけたりします。

その他

- 組み立てに必要な人: 1-2。
- 組立時間: 約0.5~1時間。

⚠️ 部品を確認する

- ネジ類などの部品番号、形状を説明書の部品一覧で確認してください。
- 部品をなくさないように纏めて置いてください。
- 部品を取り出すときに使う分だけ取り出してください。

DETAILS

DETAILS
DÉTAILS/POINTS DE MONTAGE
NOTE PARTICOLARI

DETALLES
組み立てのポイント
詳細情報

UNIT:INCH/CM/厘米

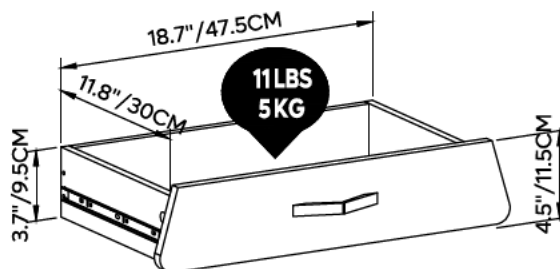
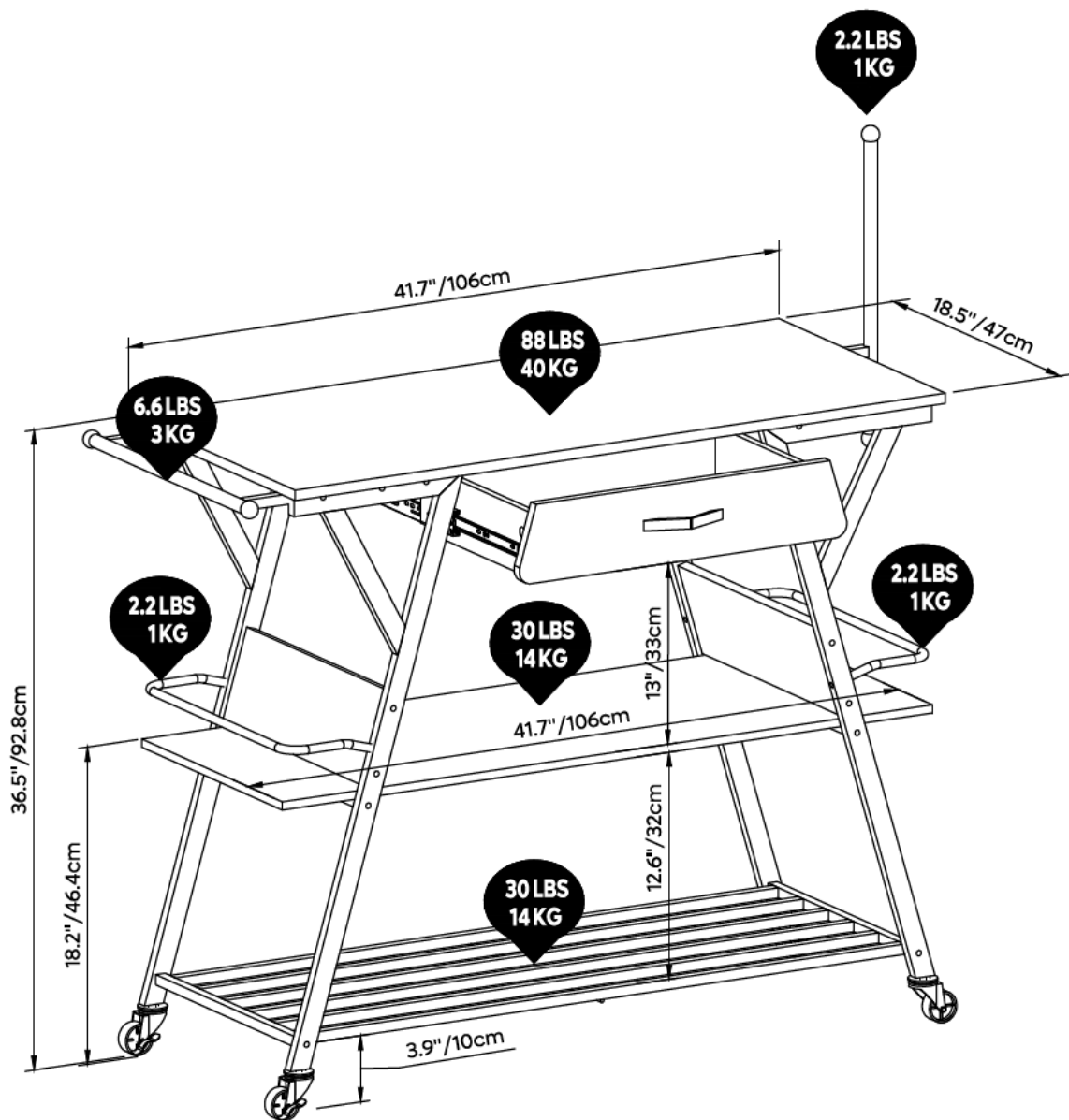

DETAILS

DETAILS
DÉTAILS/POINTS DE MONTAGE
NOTE PARTICOLARI



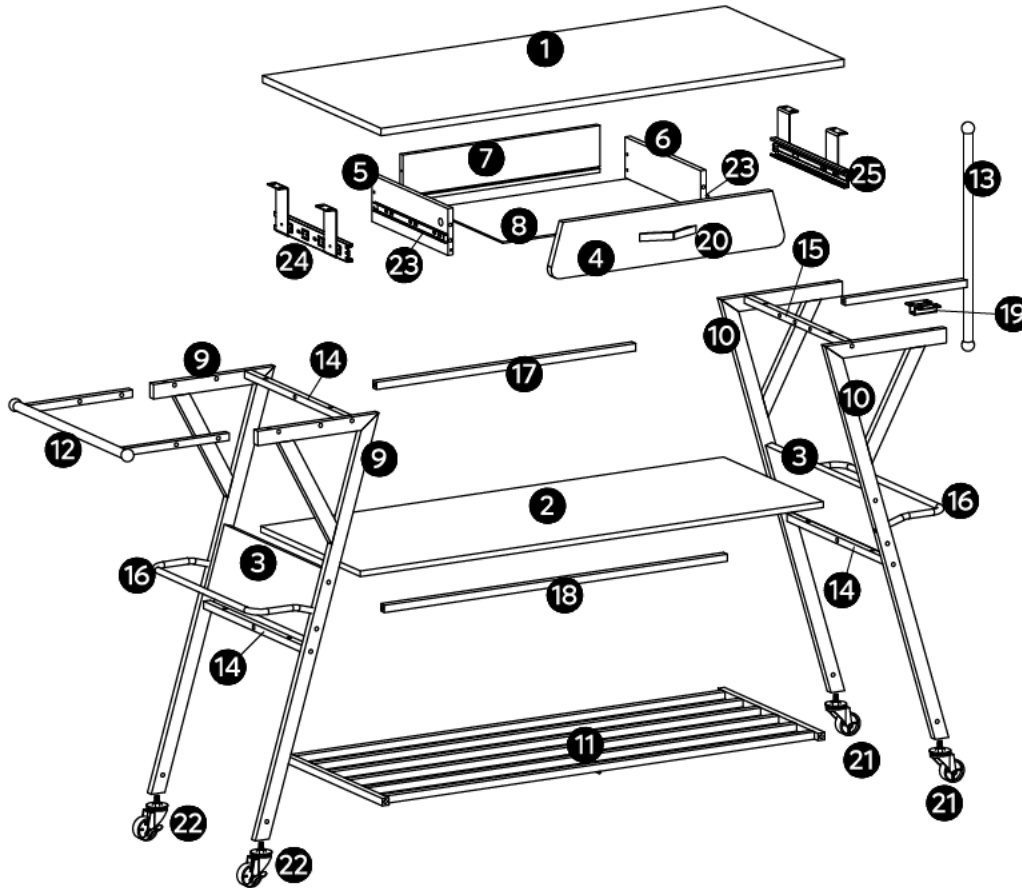

DETALLES
組み立てのポイント
詳細情報



PART LIST

STÜCKLISTE
LISTE DES PIÈCES
ELENCO DEI PEZZI



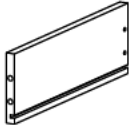
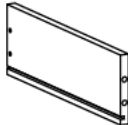









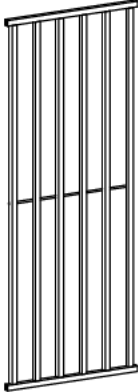

LISTA DE PIEZAS
部品の確認
部件清单

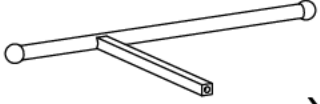
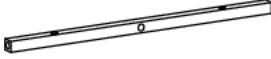
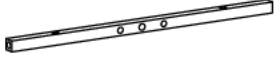
<p>1</p>  <p>X1</p>	<p>2</p>  <p>X1</p>	<p>3</p>  <p>X2</p>
<p>4</p>  <p>X1</p>	<p>5</p>  <p>X1</p>	<p>6</p>  <p>X1</p>

PART LIST

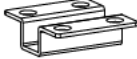
STÜCKLISTE
LISTE DES PIÈCES
ELENCO DEI PEZZI



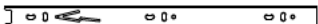
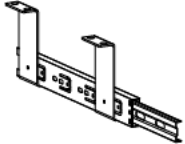
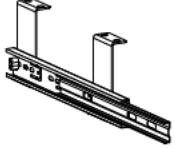

LISTA DE PIEZAS
部品の確認
部件清单

<p>7</p>  <p>X1</p>	<p>8</p>  <p>X1</p>	<p>9</p>  <p>X2</p>	
<p>10</p>  <p>X2</p>	<p>11</p>  <p>X1</p>	<p>12</p>  <p>X1</p>	
<p>13</p>  <p>X1</p>	<p>14</p>  <p>X3</p>	<p>15</p>  <p>X1</p>	
<p>16</p>  <p>X2</p>	<p>17</p>  <p>Short Court Corto Kurz 短い Corto 短的</p> <p>X1</p>	<p>18</p>  <p>Long Long Largo Lang 長い Lungo 长的</p> <p>X1</p>	
<p>19</p>  <p>X1</p>	<p>20</p>  <p>X1</p>	<p>21</p>  <p>X2</p>	
<p>22</p>  <p>X2</p>	<p>23</p>  <p>X2</p>	<p>24</p>  <p>X1</p>	<p>25</p>  <p>X1</p>

ACCESSORY LIST

ZUBEHÖRLISTE
LISTE DES ACCESSOIRES
ELENCO DEGLI ACCESSORI

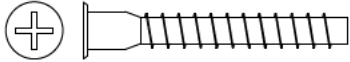
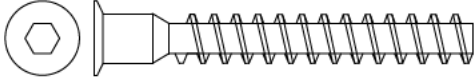
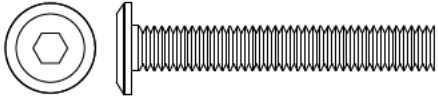
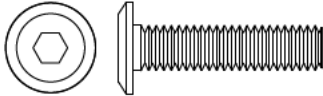
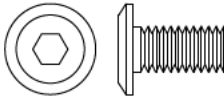
LISTA DE ACCESORIOS
付属品部品の確認
配件清单

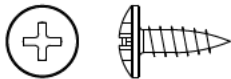
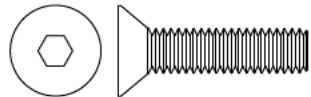
A	ST6x35mm	4+1	
B	Ø15mm	4+1	
C	ST5x35mm	4+1	
D	ST7x50mm	8+1	
E	M6x40mm	12+1	
F	M6x25mm	21+1	
G	M6x12mm	12+1	
H	M6	4+1	
I	M4x20mm	2	
J	ST4x12mm	6+1	
K	M6x25mm	4+1	

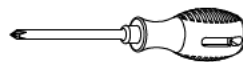

Detailed Installation for Accessory A B

Installation détaillée pour l'accessoire A B
 Detaillierte Installation des Zubehörs A B
 Installazione dettagliata per l'accessorio A B
 Instalación detallada del accesorio A B
 カムロック取り付け方
 配件A、B详细安装

1

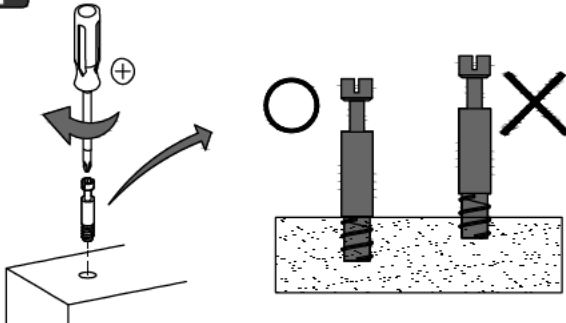

Screw cam dowel on the panel.
 Vissez la goupille de came au panneau.
 Nockendübel auf die Platte schrauben.
 Avvitare il tassello a camme sul pannello.
 tornillo de pasador de leva en el panel.
 カムロックネジを部品に取り付ける。
 螺杆用十字螺丝刀装入对应的预留孔内

Place another panel via the dowel.
 Placez un autre panneau par le goujon.
 Setzen Sie eine weitere Platte über den Dübel ein.
 Posizionare un altro pannello tramite il tassello.
 Coloque otro panel a través del pasador.
 カムロックネジをカムロック穴に差し込む。
 螺杆插入对应孔位，将两块板材对接起来。

2

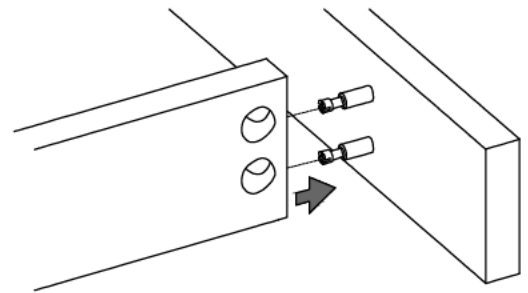

3

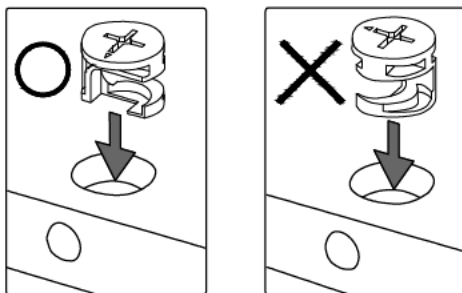

Pay attention to the direction of cam lock when putting it into hole.
 Faites attention à la direction du verrou à came en entrant dans le trou.
 Achten Sie auf die Richtung des Nockenschlosses, wenn Sie es in das Loch stecken.
 Fare attenzione alla direzione della serratura a camme quando lo si inserisce nel foro.
 Preste atención a la dirección de la leva de fijación al insertarla en el orificio.
 カムロックネジの方向にカムロックの穴の穴の向きを合わせ取り付け。
 装入锁扣圆盘，注意锁扣圆盘的方向；

Tighten up cam lock clockwise until it stops.
 Serrez le verrou à came dans le sens des aiguilles d'une montre jusqu'à ce qu'il s'arrête.
 Ziehen Sie die Nockenverriegelung im Uhrzeigersinn bis zum Anschlag an.
 Stringere la serratura a camme in senso orario fino all'arresto.
 Apriete la leva de fijación en sentido horario hasta el tope.
 カムロックをドライバーで締め固定する。
 顺时针旋转锁扣圆盘并锁紧。

4

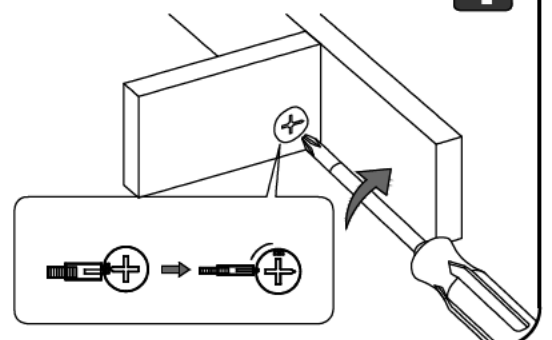

1

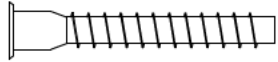
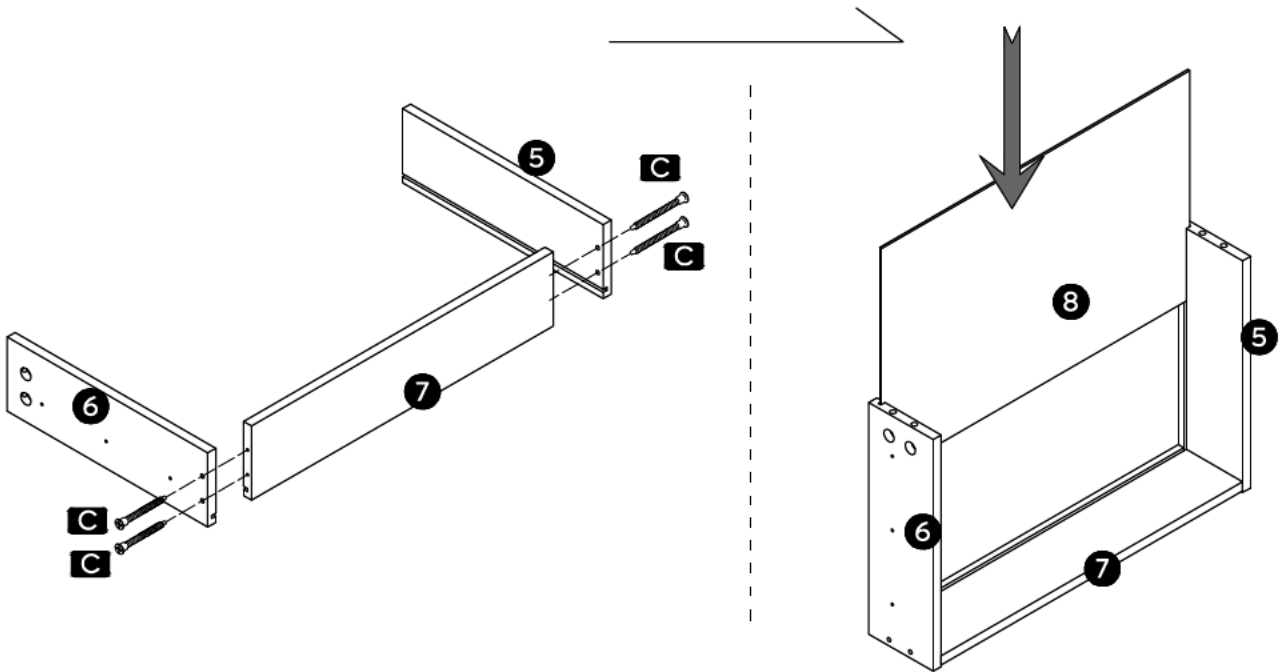

C ST5x35mm x 4

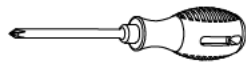

2

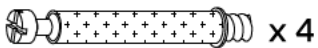
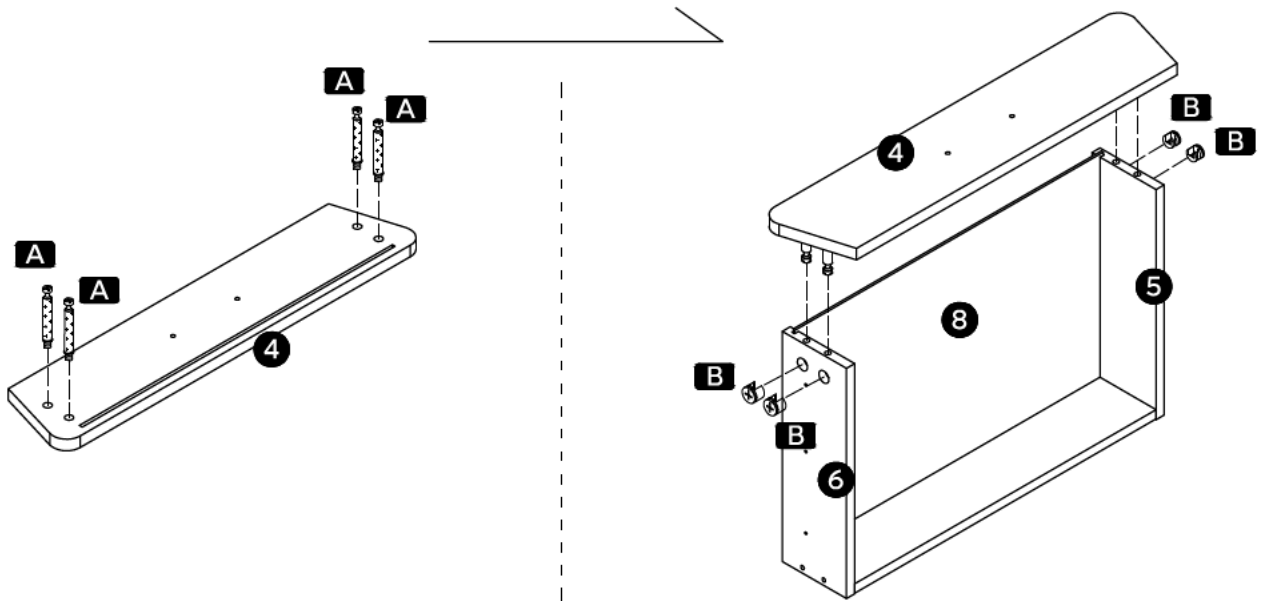

x 4

A ST6x35mm



x 4

B Ø15mm

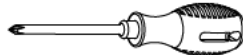

3

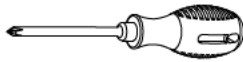
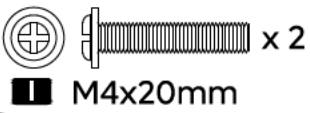
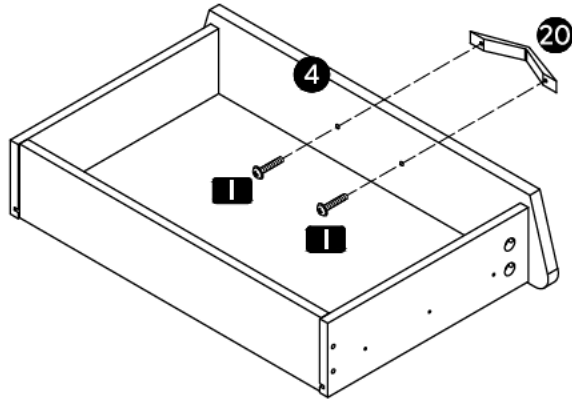

4

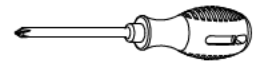
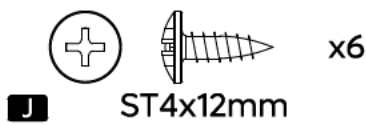
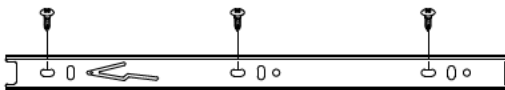
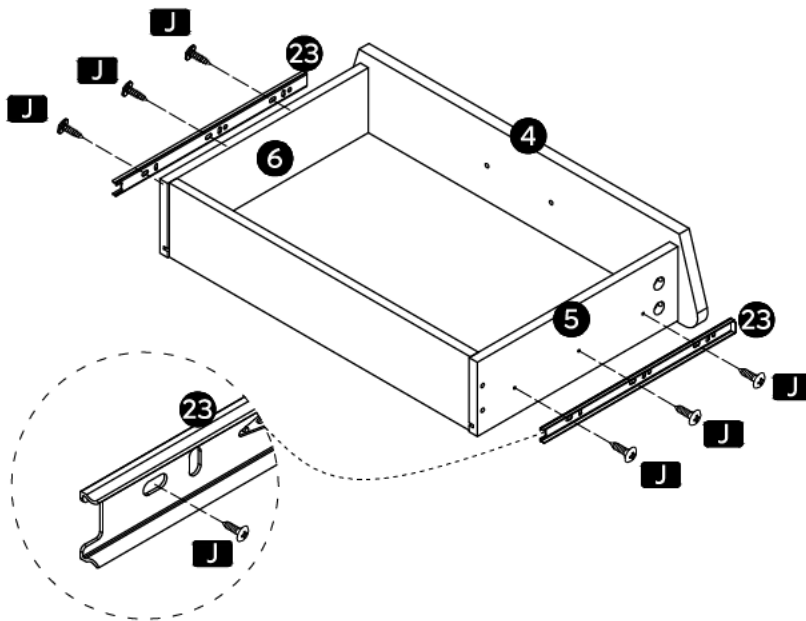

5

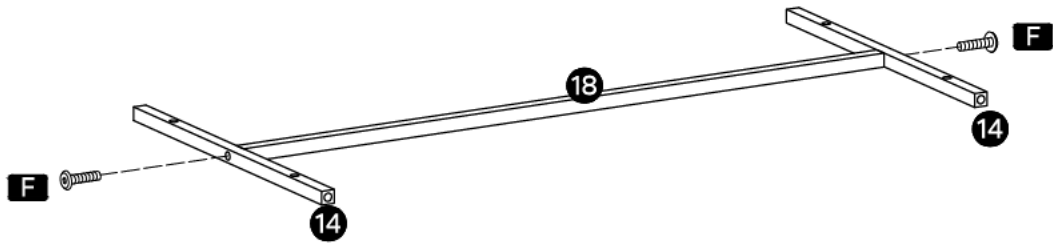

F



x2

M6x25mm



6

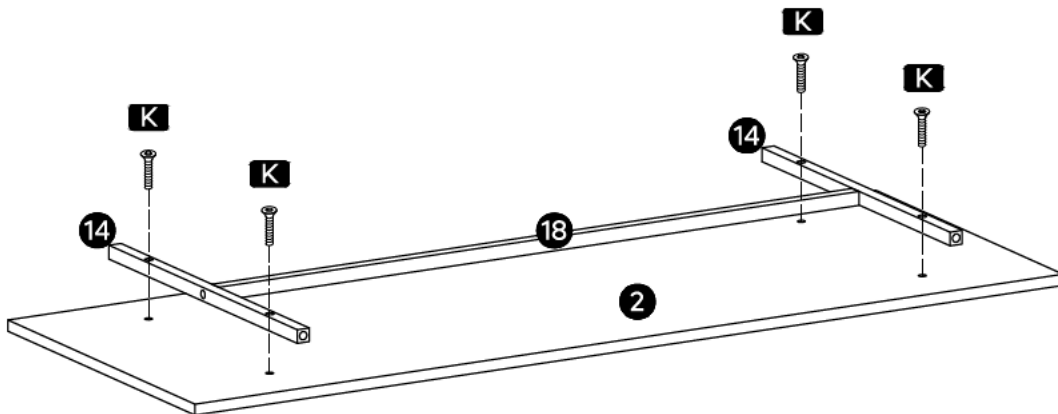

K

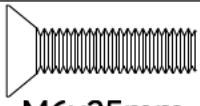

x4

M6x25mm



7

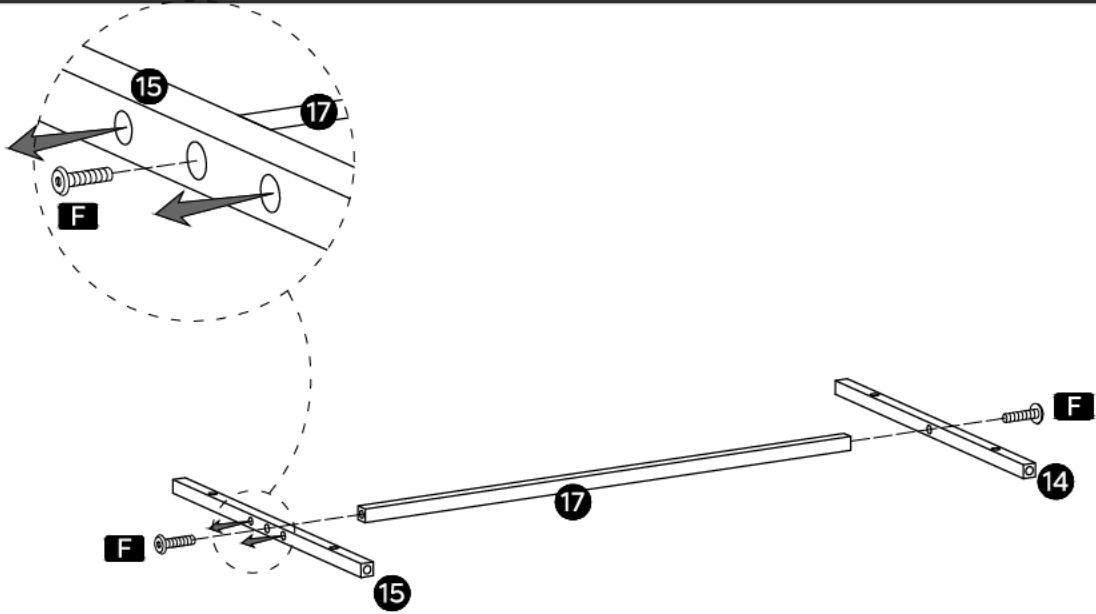

F

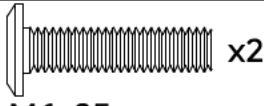

x2

M6x25mm



8

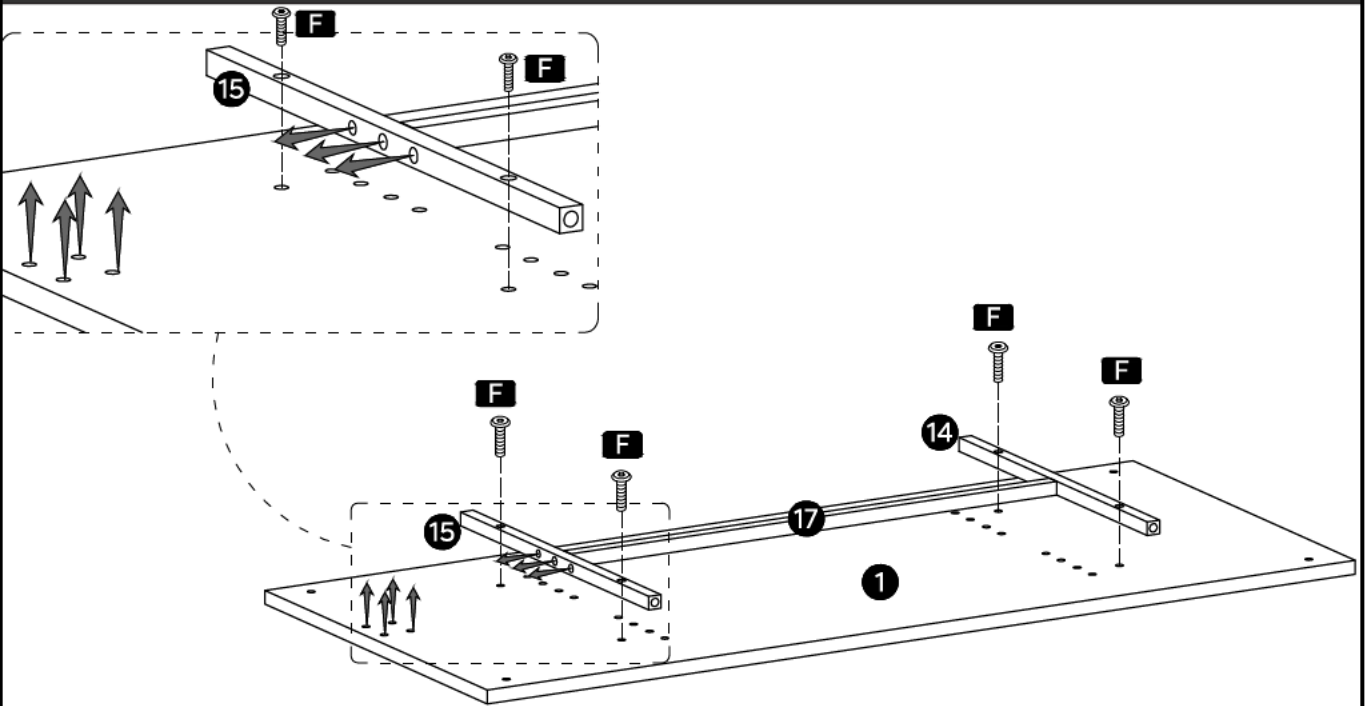

F

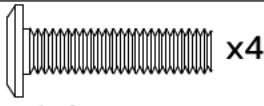

x4

M6x25mm



9

 70% tighten
 70 % serré
 70% festziehen
 Serraggio al 70%
 70 % reforzado
 70%締め付け
 70%锁紧

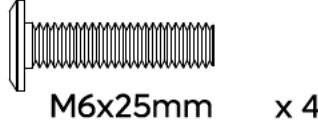
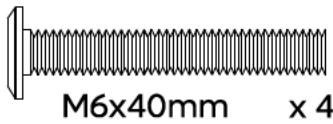
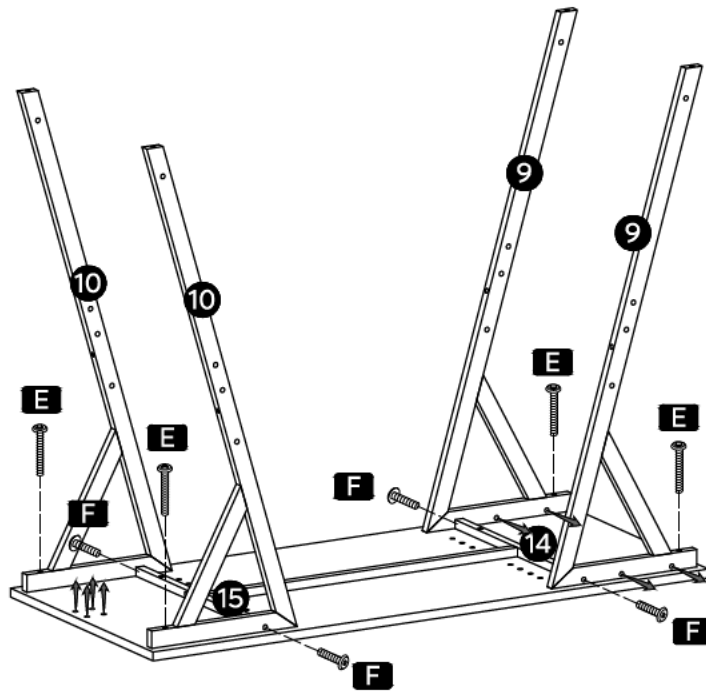

10

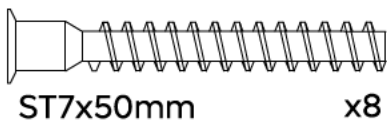
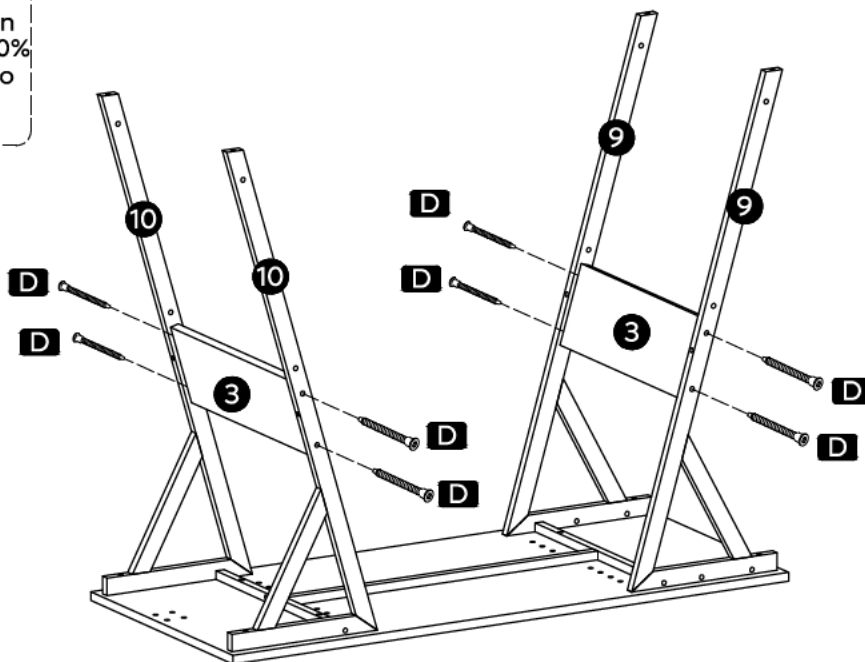

 70% tighten
 70 % serré
 70% festziehen
 Serraggio al 70%
 70 % reforzado
 70%締め付け
 70%锁紧



11

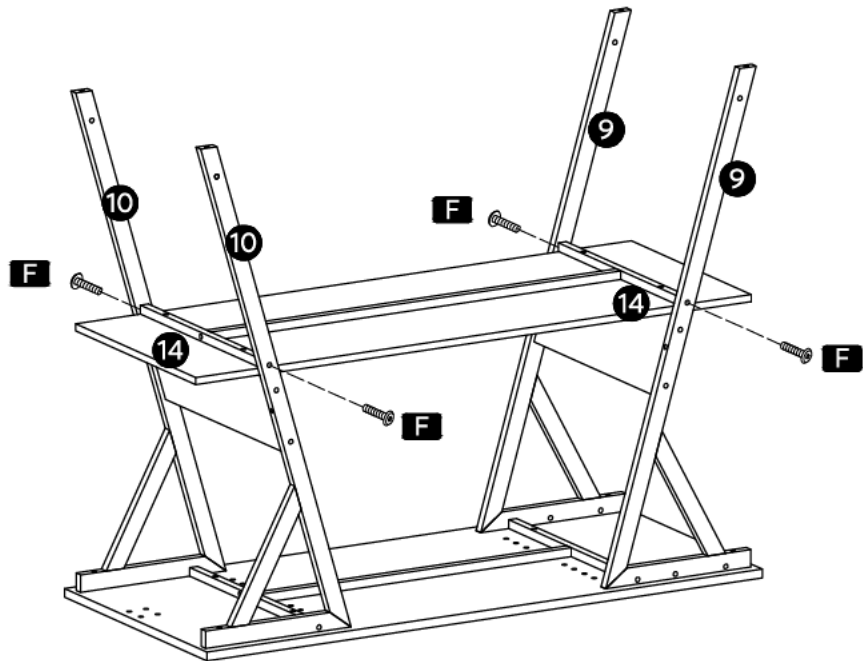

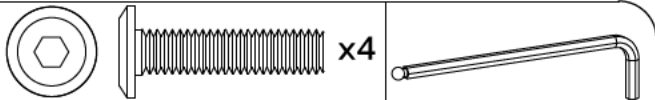
 70% tighten
 70 % serré
 70% festziehen
 Serraggio al 70%
 70 % reforzado
 70%締め付け
 70%锁紧



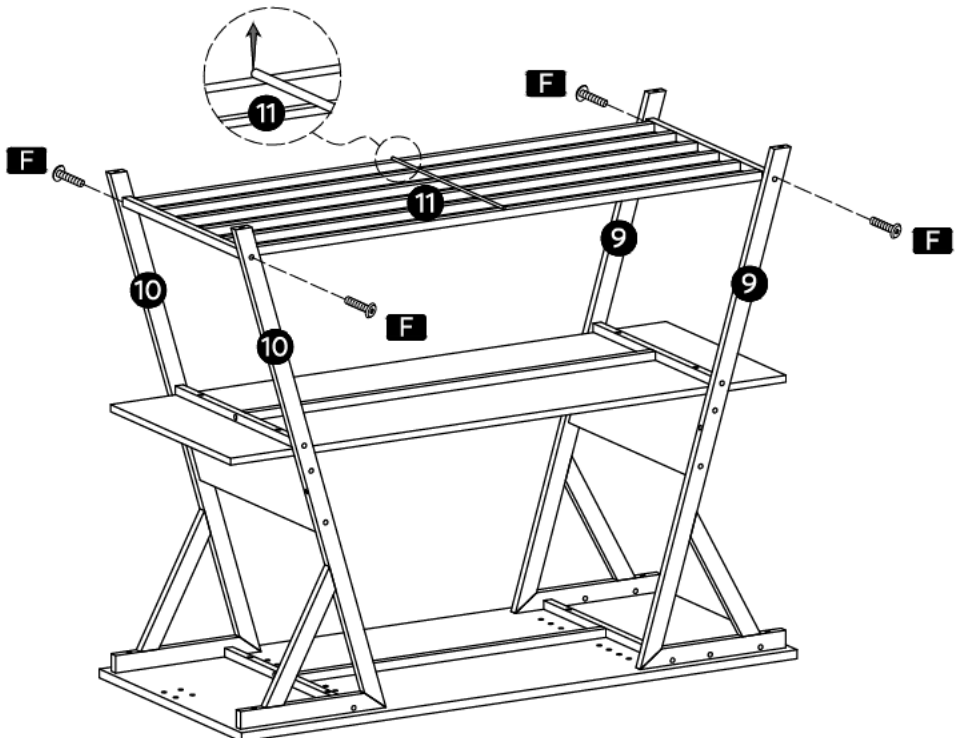

 x4
F M6x25mm

12

 100% tighten
 100 % serré
 100% festziehen
 Serraggio al 100%
 100 % reforzado
 100%締め付け
 100%锁紧

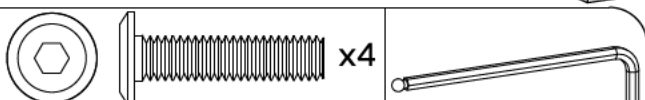

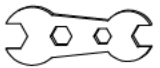
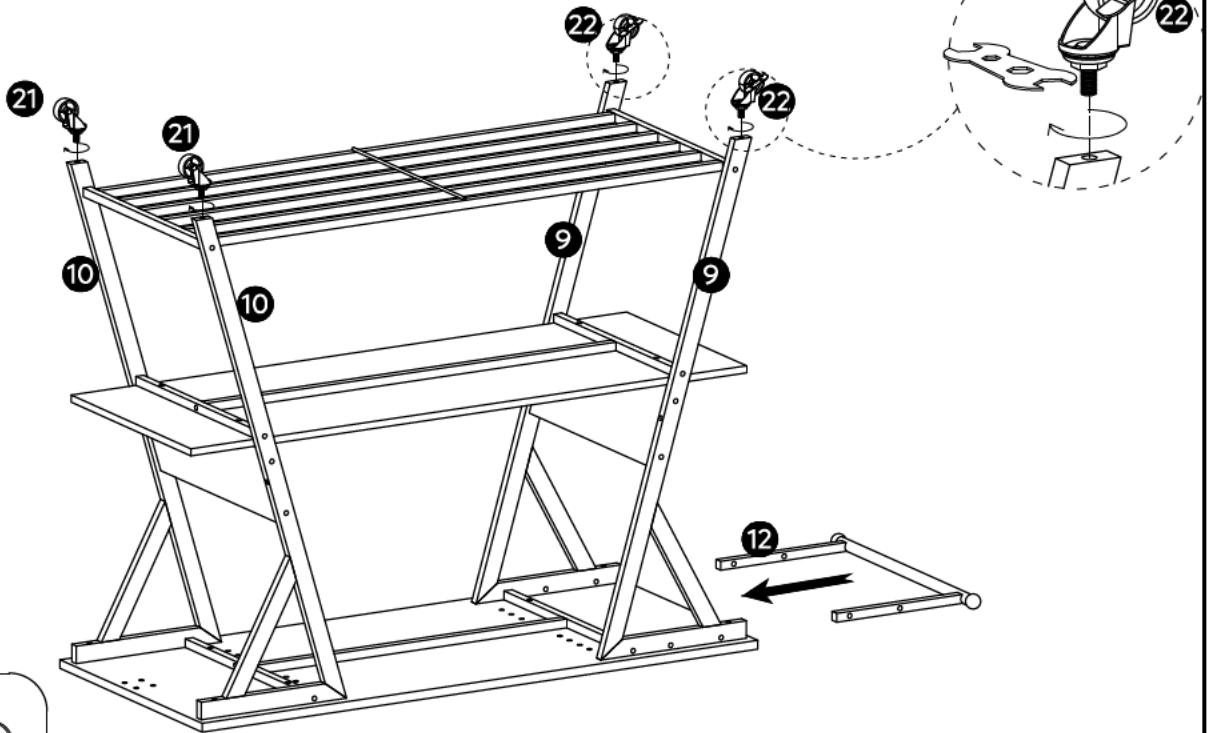

 x4
F M6x25mm

13

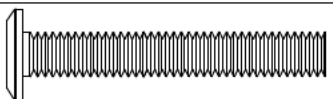
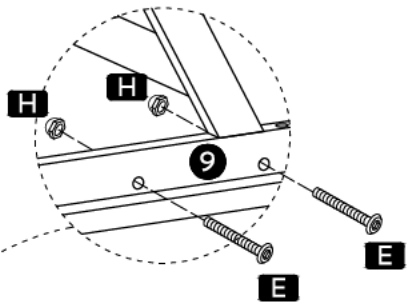
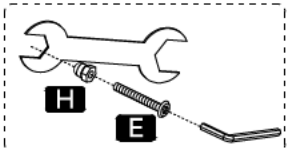
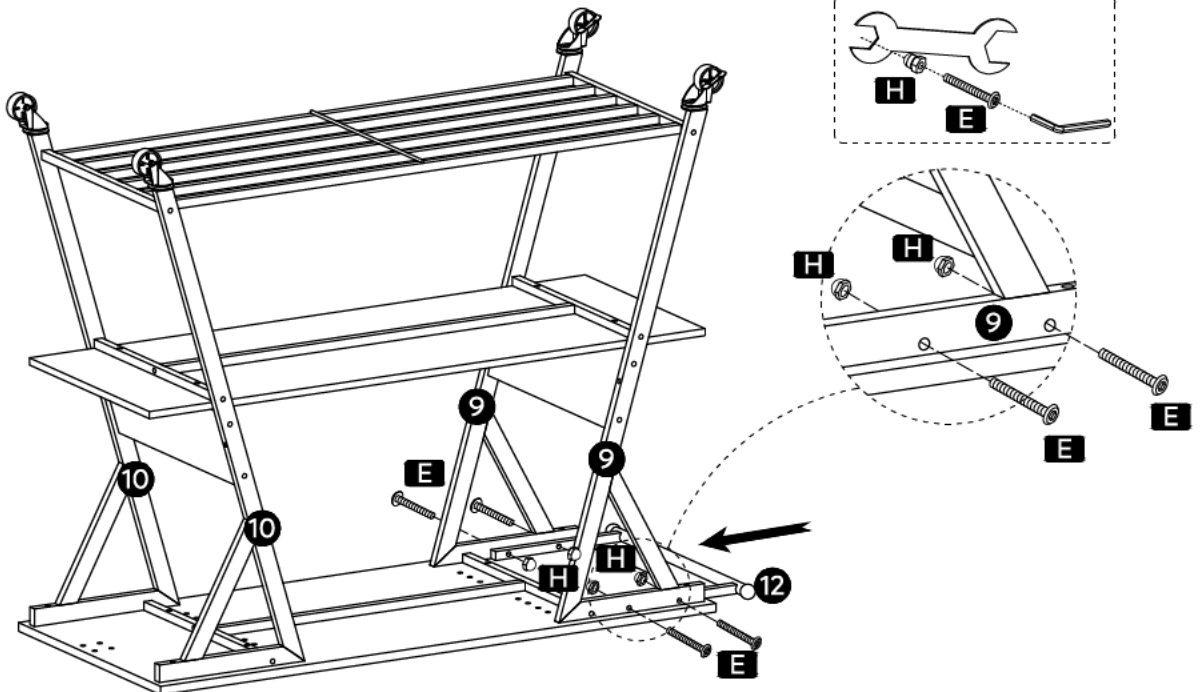

14



E

M6x40mm x4



x4

H M6mm

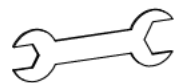

- A** Style A: Step 15-18
Style A : Étape 15-18
Ausführung A: Schritt 15-18
Stile A: Step 15-18
Estilo A: paso 15-18
スタイルA: ステップ^o15-18
安装方式A: 步骤15-18



- B** Style B: Step 19-22
Style B : Étape 19-22
Ausführung B: Schritt 19-22
Stile B: Step 19-22
Estilo B: paso 19-22
スタイルB: ステップ^o19-22
安装方式B: 步骤19-22



(A)

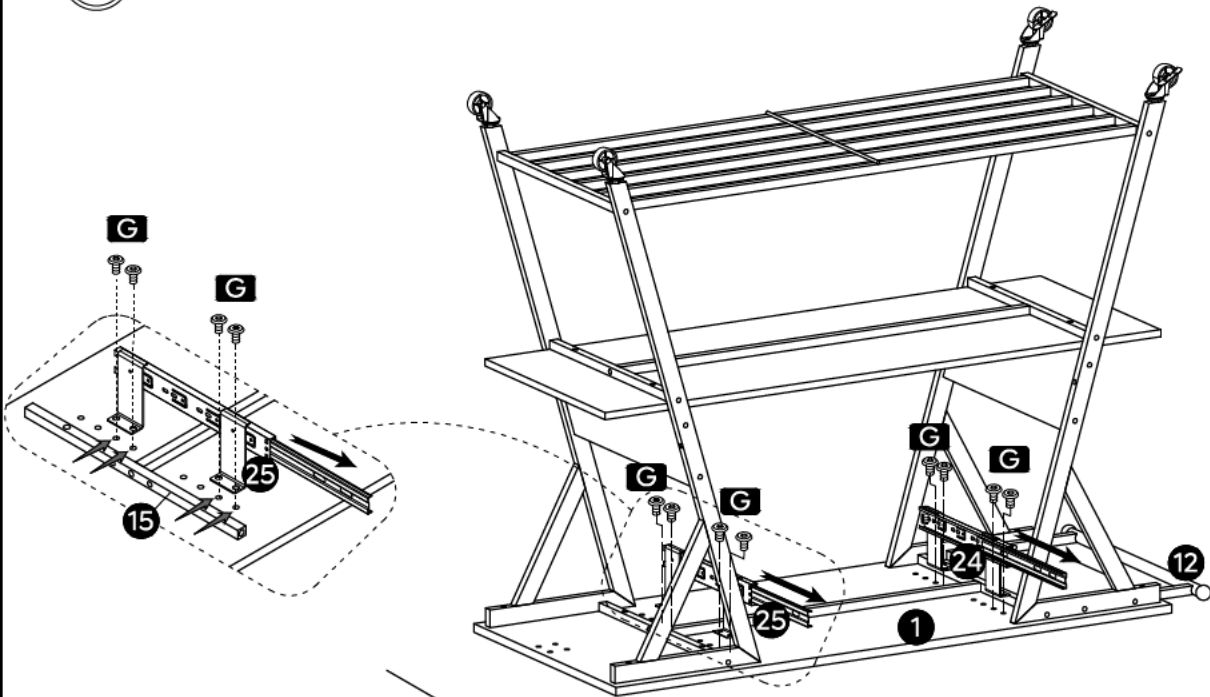

Front

De face
VORDERSEITE
DAVANTI
PARTE DELANTERA
フロント
前

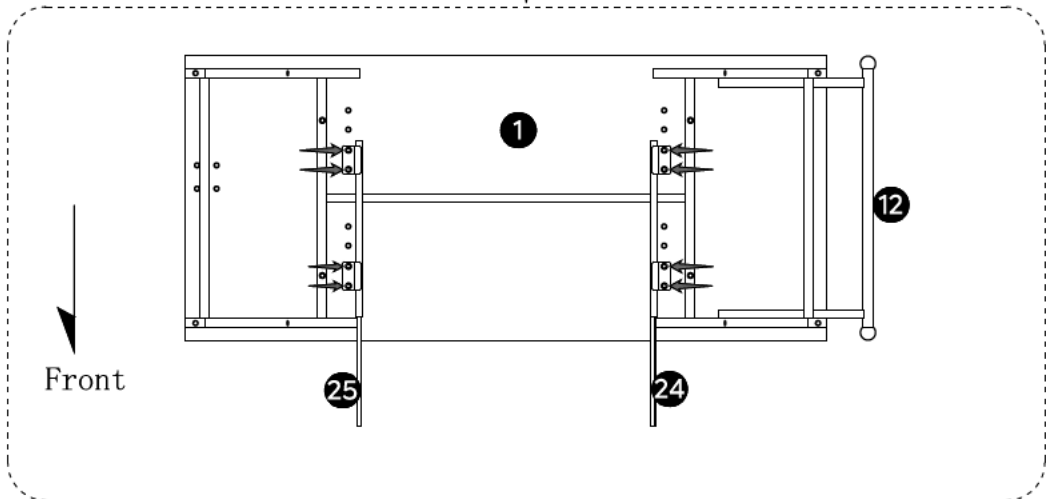

Front



G

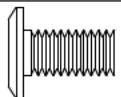

x8

M6x12mm



16

A

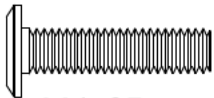
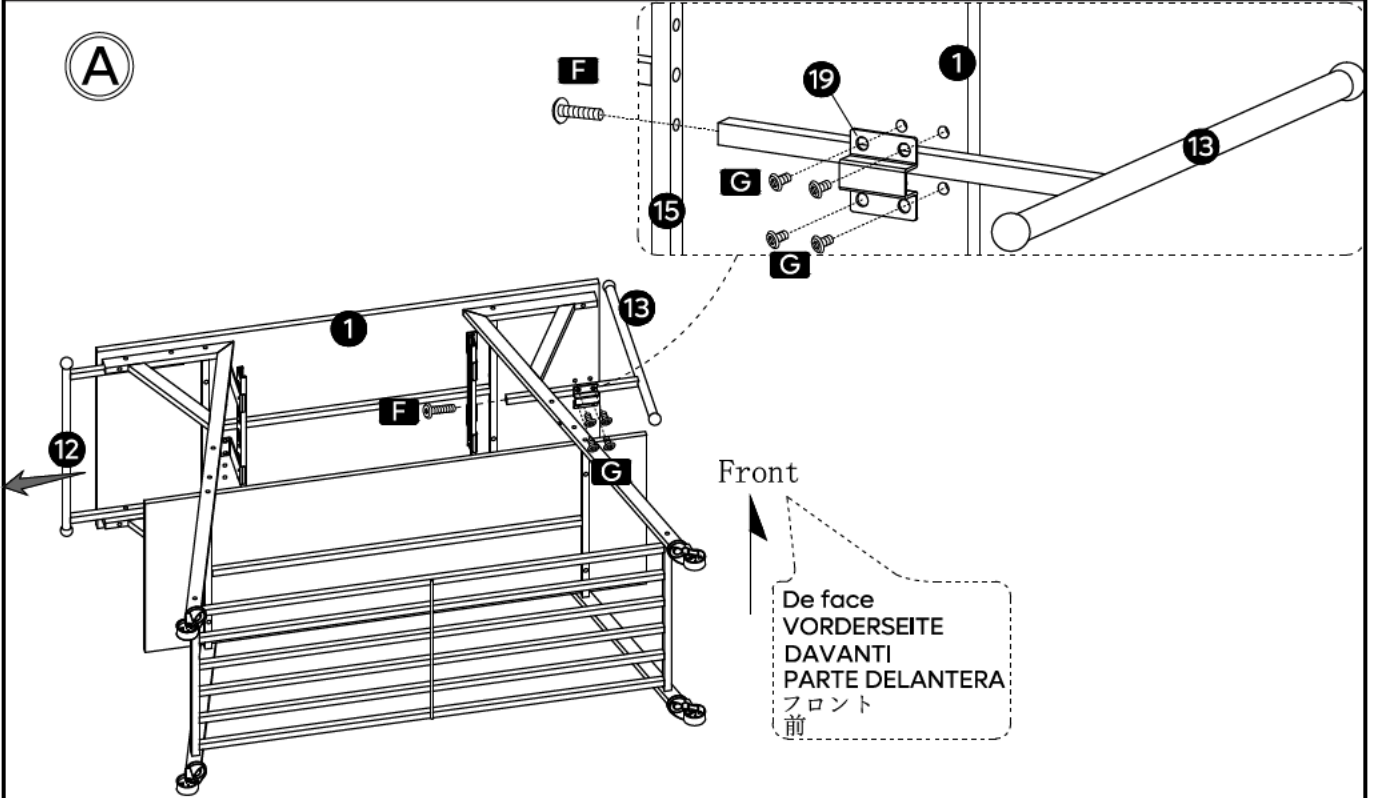

M6x25mm

x1

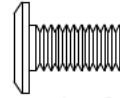

M6x12mm

x4



A

17

De face
VORDERSEITE
DAVANTI
PARTE DELANTERA
フロント
前

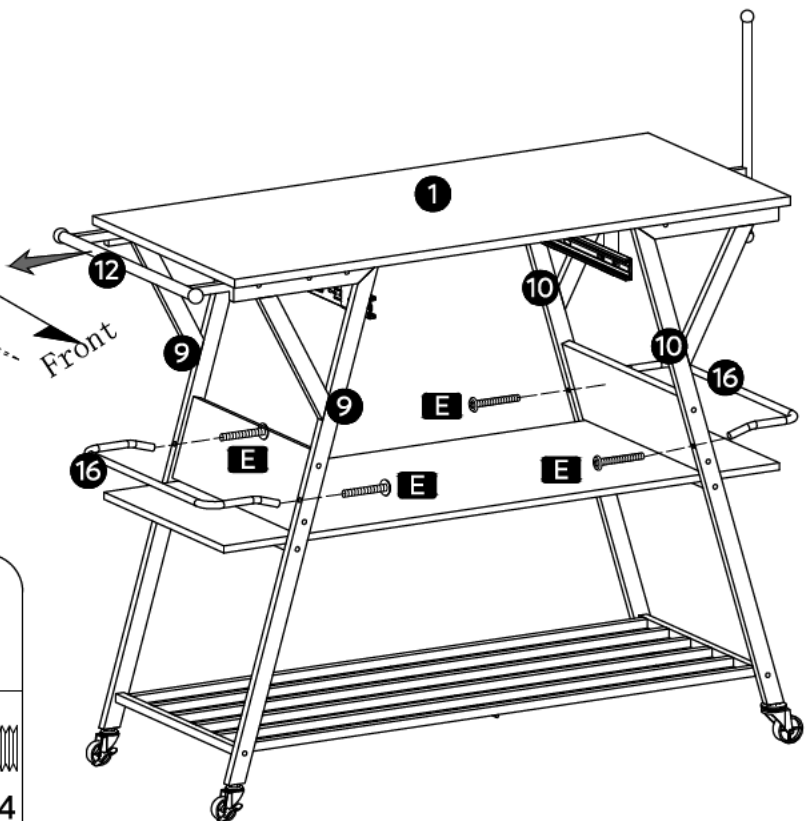

M6x40mm

x 4

A

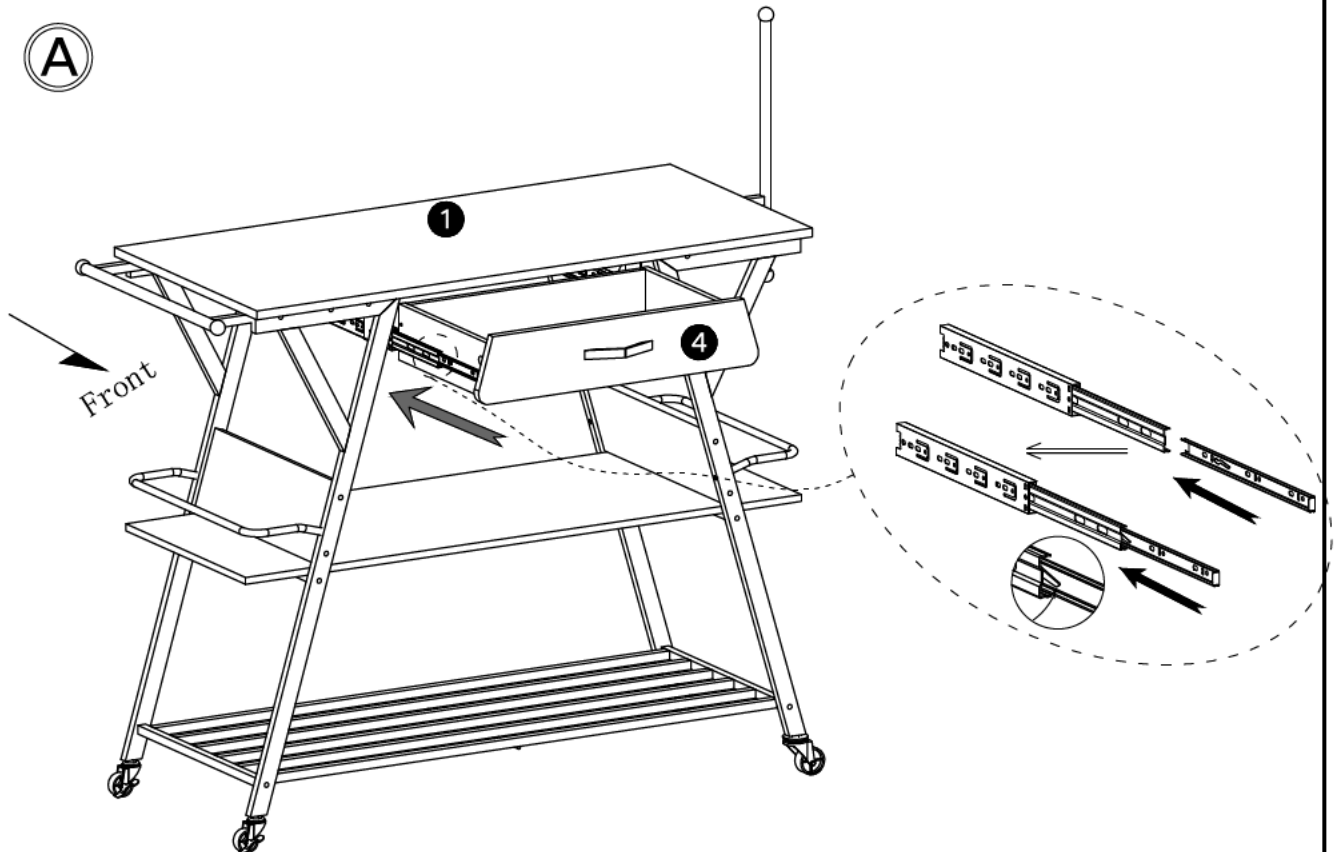
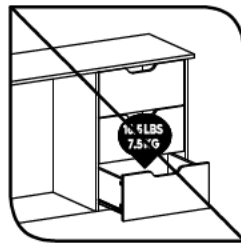
**STOP!****OVERLOAD!****WARNING**

- * Never allow children to climb or hang on drawers, handles, towel rack, paper towel holder.
- * Do not overload.

"AVERTISSEMENT"

- * Ne pas laisser les enfants grimper ou s'accrocher aux tiroirs, poignées, porte-serviettes, porte-essuie-tout.
- * Ne pas surcharger.

ACHTUNG

- * Erlauben Sie Kindern nicht, auf Schubladen, Griffe, Handtuchhalter und Papiertuchhalter zu klettern oder sich daran zu hängen.
- * Nicht überlasten

AVVERTENZA

- * Non consentire mai ai bambini di arrampicarsi o aggrapparsi a cassetti, maniglie, portasciugamani, porta asciugamani di carta.
- * Non sovraccaricare.

ADVERTENCIA

- * Nunca permita que los niños se suban o se cuelguen de los cajones, las manijas, el toallero o el soporte para toallas de papel.
- * No sobrecargue.

警告

- * 引き出し、取っ手、タオル掛け、ペーパータオルホルダーにお子様に登ったり、ぶら下がったりしないように十分注意してください。
- * 無理な荷重を加えないようにしてください。

警告

- * 切勿让儿童攀爬或悬挂在抽屉、把手、毛巾架、纸巾架上。
- * 不要超载。

(B)

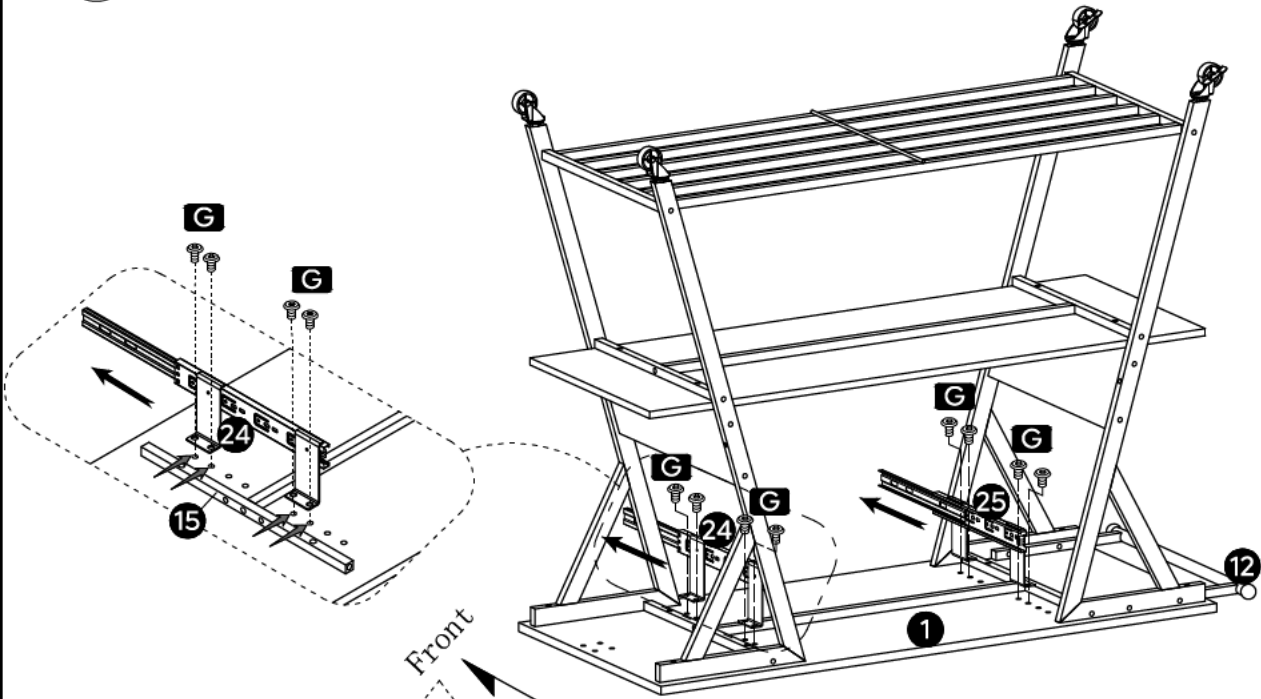

De face
VORDERSEITE
DAVANTI
PARTE DELANTERA
フロント
前

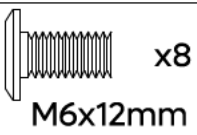
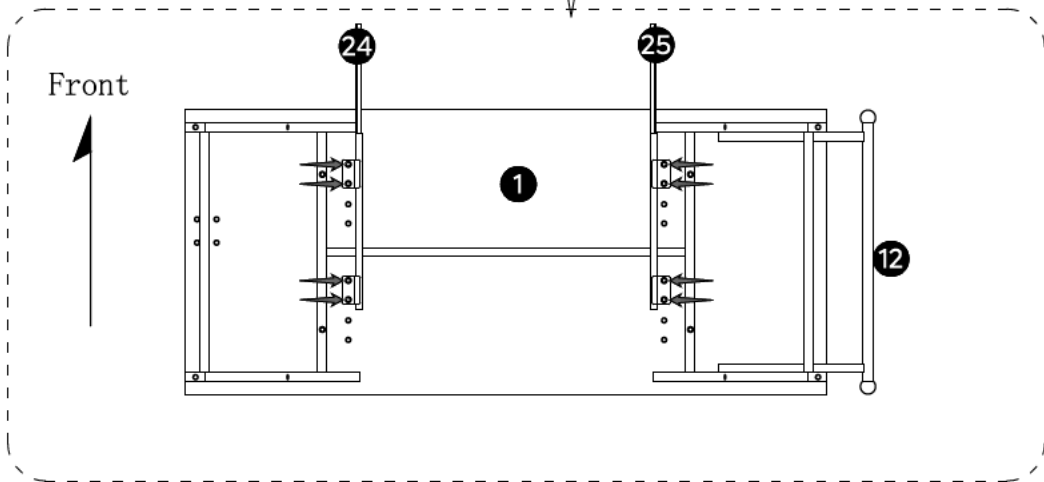

20

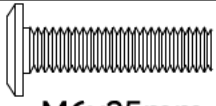
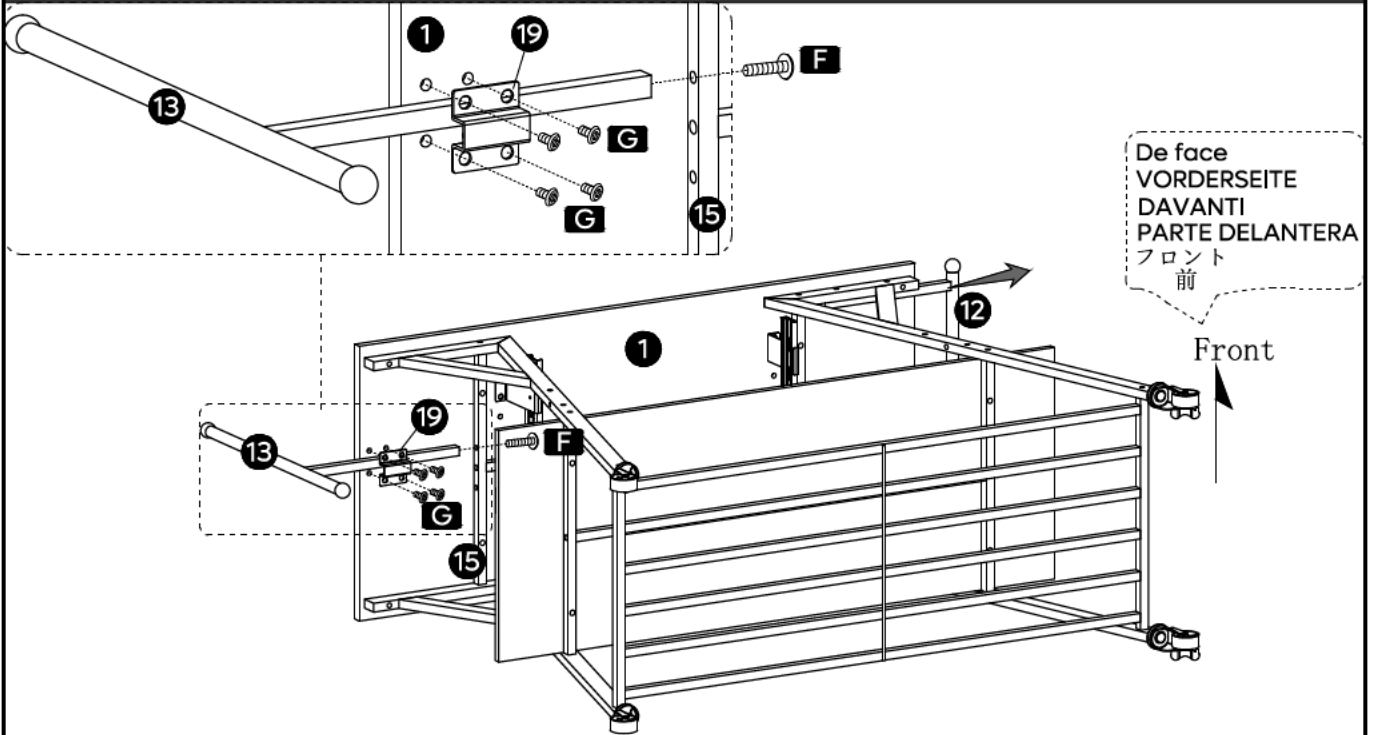

M6x25mm

x1

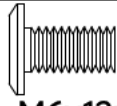

M6x12mm

x4



21

(B)

De face
VORDERSEITE
DAVANTI
PARTE DELANTERA
フロント
前

Front

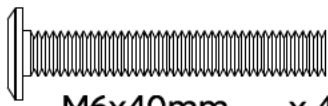
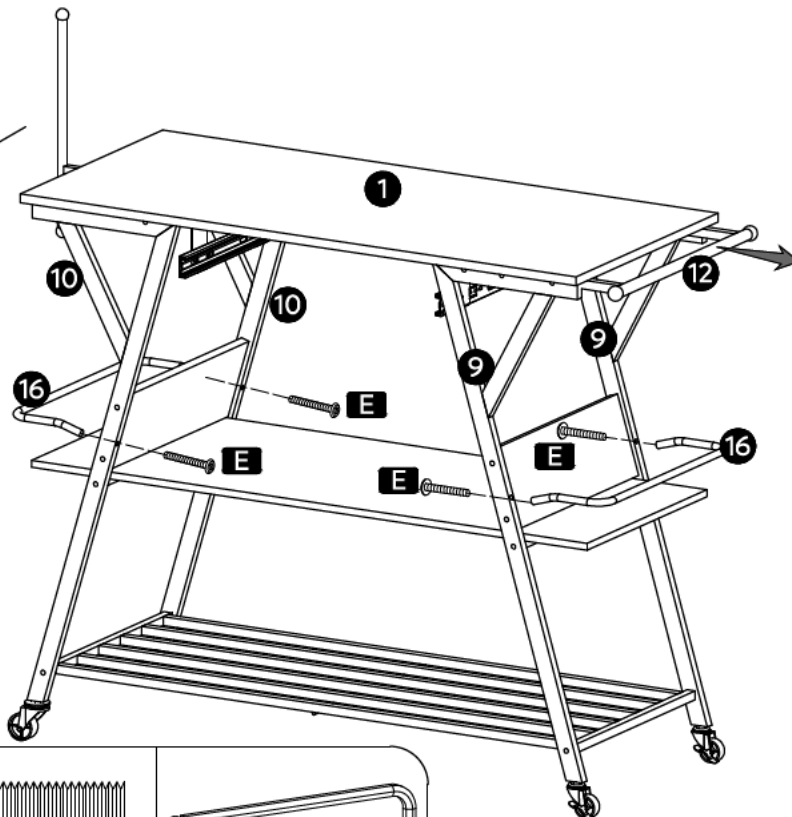

M6x40mm

x 4

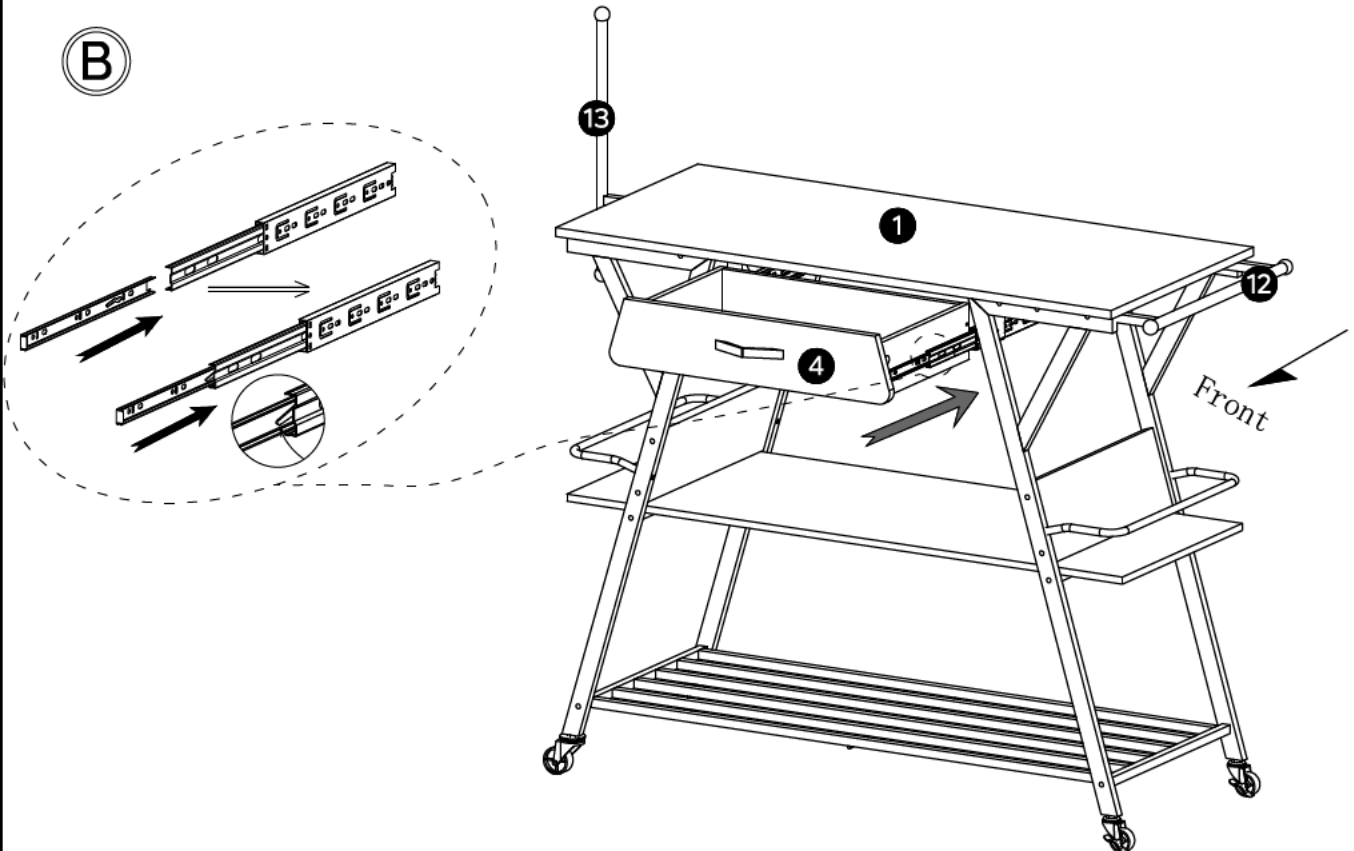
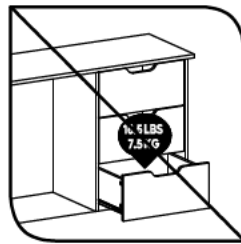

B

**STOP!****OVERLOAD!****WARNING**

- * Never allow children to climb or hang on drawers, handles, towel rack, paper towel holder.
- * Do not overload.

"AVERTISSEMENT"

- * Ne pas laisser les enfants grimper ou s'accrocher aux tiroirs, poignées, porte-serviettes, porte-essuie-tout.
- * Ne pas surcharger.

ACHTUNG

- * Erlauben Sie Kindern nicht, auf Schubladen, Griffe, Handtuchhalter und Papiertuchhalter zu klettern oder sich daran zu hängen.
- * Nicht überlasten

AVVERTENZA

- * Non consentire mai ai bambini di arrampicarsi o aggarrarsi a cassetti, maniglie, portasciugamani, porta asciugamani di carta.
- * Non sovraccaricare.

ADVERTENCIA

- * Nunca permita que los niños se suban o se cuelguen de los cajones, las manijas, el toallero o el soporte para toallas de papel.
- * No sobrecargue.

警告

- * 引き出し、取っ手、タオル掛け、ペーパータオルホルダーにお子様に登ったり、ぶら下がったりしないように十分注意してください。
- * 無理な荷重を加えないようにしてください。

警告

- * 切勿让儿童攀爬或悬挂在抽屉、把手、毛巾架、纸巾架上。
- * 不要超载。

