





KEEP INSTRUCTIONS  
FOR FUTURE USE

## Assembly Instructions

ASSEMBLY REQUIRES  
TWO PEOPLE



Hardware and Tools		
A	BOLT 0.39" x 2.36" Ø 10mm x 60mm	
	Qty: 08	
B	WASHER 0.39" x 0.91" x 0.08" Ø 10mm x 23mm x 2.0mm	
	Qty: 08	
C	OPEN WRENCH K17	
	Qty: 01	

### Components:

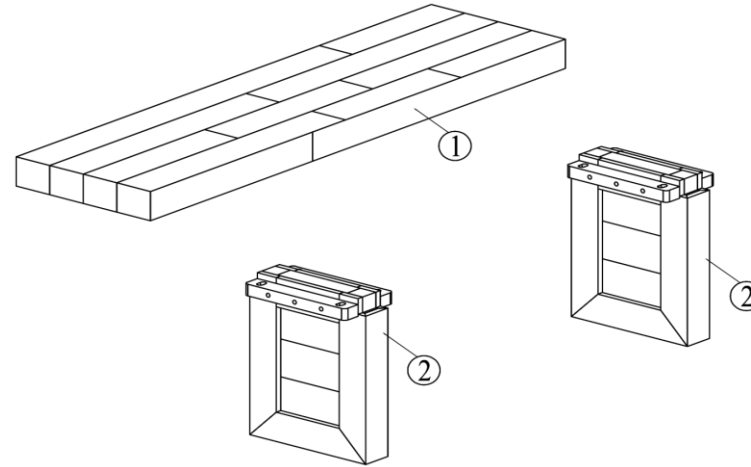

1	BENCH TOP x 1
2	LEGS x 2

### Before Starting:

1. Choose a clean, level, spacious assembly area. Avoid hard surfaces that may damage the product.
2. Always read the instructions carefully before beginning assembly to ensure that you have all required contents.
3. To prevent choking hazards, keep the packaging material out of reach of small children
4. Do not over tighten the bolts as this may damage the thread.
5. Use only vendor supplied hardware to assemble. Using unauthorized hardware could jeopardize the structural integrity of the item.
6. The use of power tools to aid in assembly is not recommended. Power tools can damage hardware and split wood.

### Step 1:

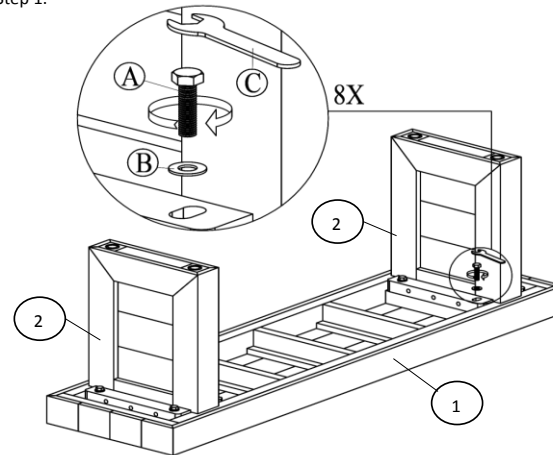

- Assemble the Legs (2) into the Bench Top (1) as picture. Tighten all Bolts (A) and Washers (B) by using Open Wrench (C).

### Step 2:

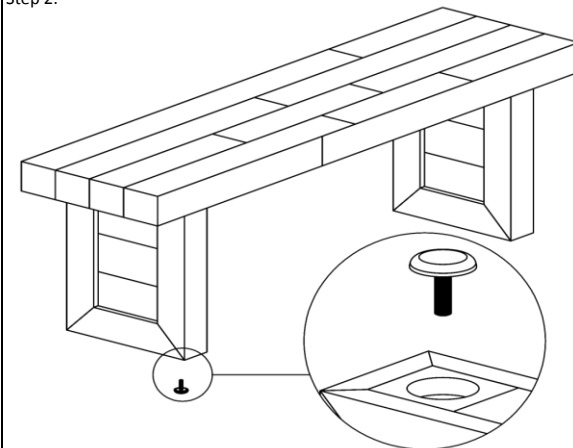

- Carefully turn the bench over and stand on its legs.  
- If the bench doesn't sit level, please adjust the adjustable feet under the legs.