

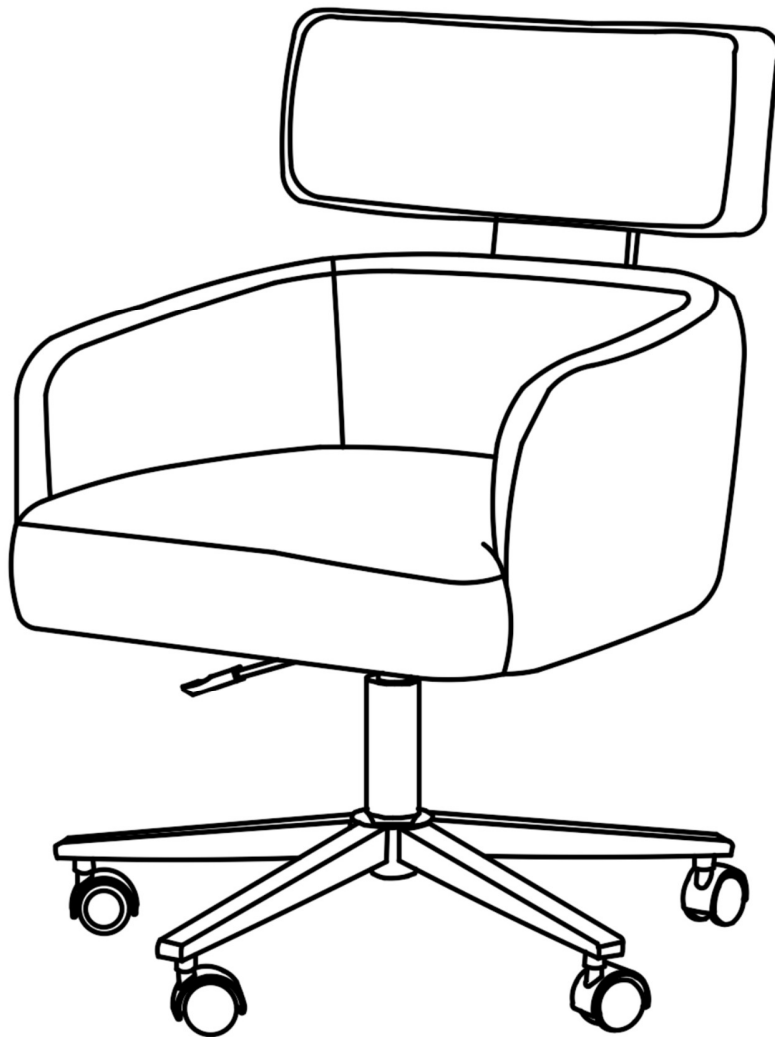







Assembling Instruction



PRODUCTS ARE NOT INTENDED
FOR COMMERCIAL USE.

MADE IN CHINA
Page 1 of 3 Pages

List of package

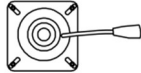
Parts#	Name	Drawing	Qty
A	Body		1
B	Bolts Ø5/16"X1-1/4"		4
C	Flat Washer		4
D	Lock Washer		4
E	Allen Key		1
F	Wheel		4
G	Gas Pole		1
H	Leg		1
I	Rotation Device		1

Step 1: Take off the hardware Box from the Main Box

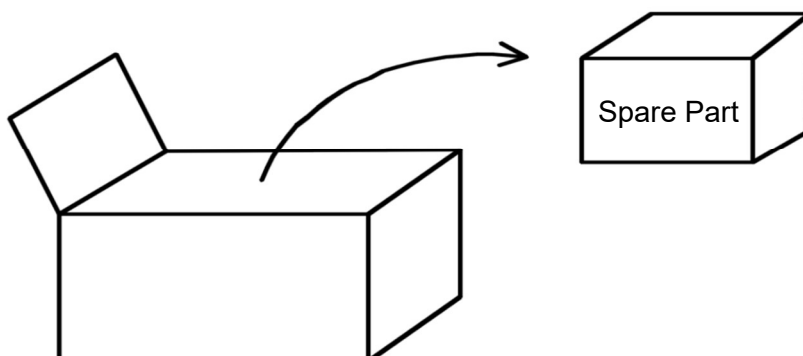

Step 2: Using bolts (B), lock washers (C), flat washers (D) to connect Rotation Device(I) to Body(A)

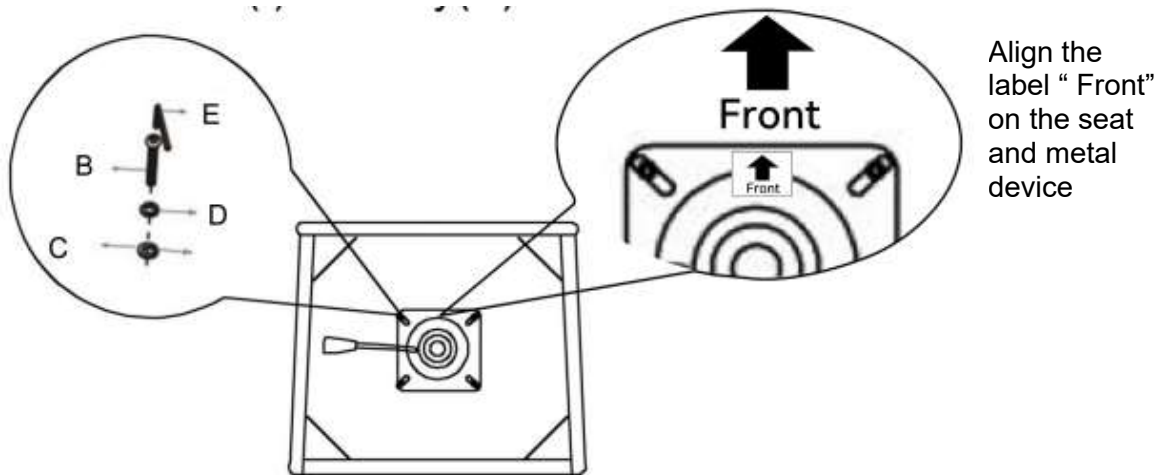

Step 3: Insert the wheels into the bottom of leg and the gas pole into the leg

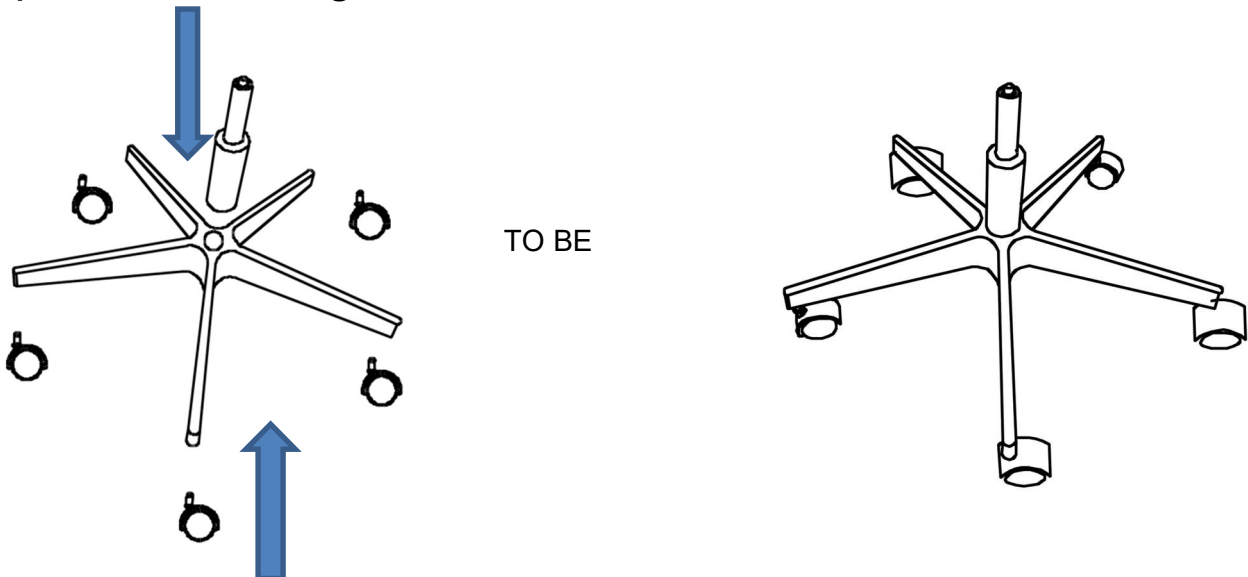

Step 4: Insert the leg into the Rotation Device under the chair body

