

# ASSEMBLY & CARE INSTRUCTIONS

## 1 Table Overview

Introducing our modern minimalist dining table, a perfect blend of style and durability. This table features a sintered stone tabletop, crafted from natural stone and fired at high temperatures. The sintered stone surface ensures unparalleled durability, resilience, and easy maintenance, with exceptional wear and corrosion resistance.

The tabletop is complemented by a solid white waxwood frame, renowned for its fine texture, distinct grain, and enduring strength. Together, these materials create a dining table that exudes timeless elegance and stability, making it a sophisticated addition to any dining space.

## 2 Included Components

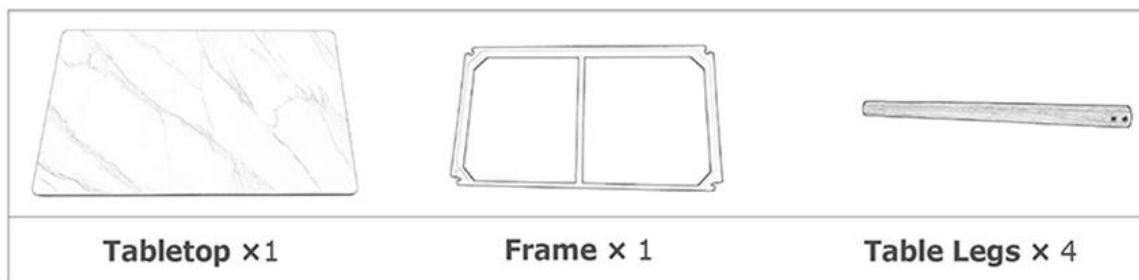

## 3 Tools Required

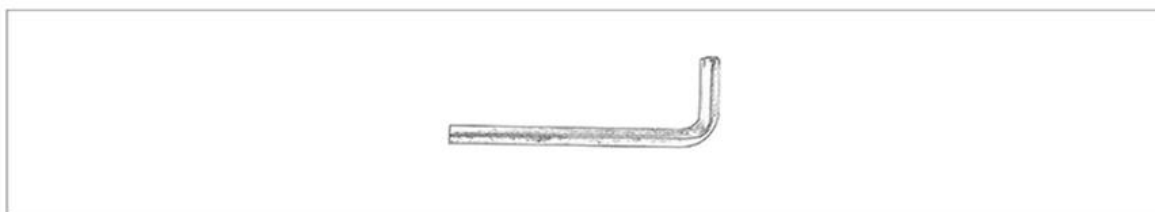

L-shaped Hex Key × 1 (provided)

•Phillips Screwdriver or Electric Screwdriver – (not included; please provide)

## 4 Parts List

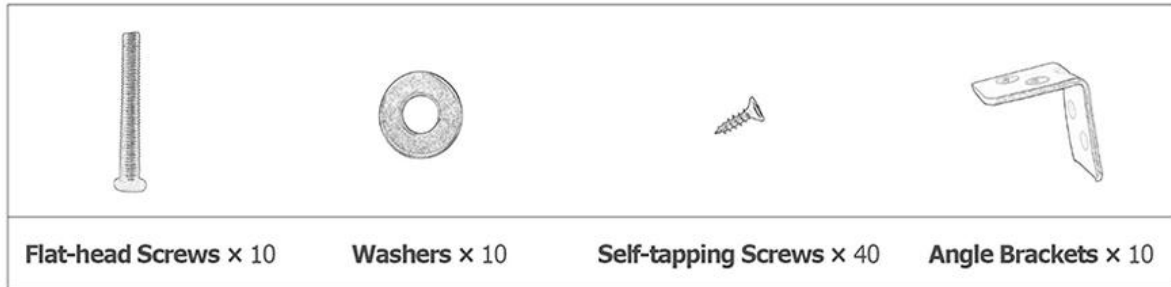

## 5 ASSEMBLY INSTRUCTIONS

### Install the Table Legs.

-----

A. Place the table frame on a flat surface. Position the table legs at the designated locations on the frame.

B. Combine the flat-head screws with the washers and insert them into the corresponding holes. Use the L-shaped hex key to tighten the flat-head screws, securing the legs to the frame.

C. Ensure that all four legs are firmly installed and the assembly is stable.

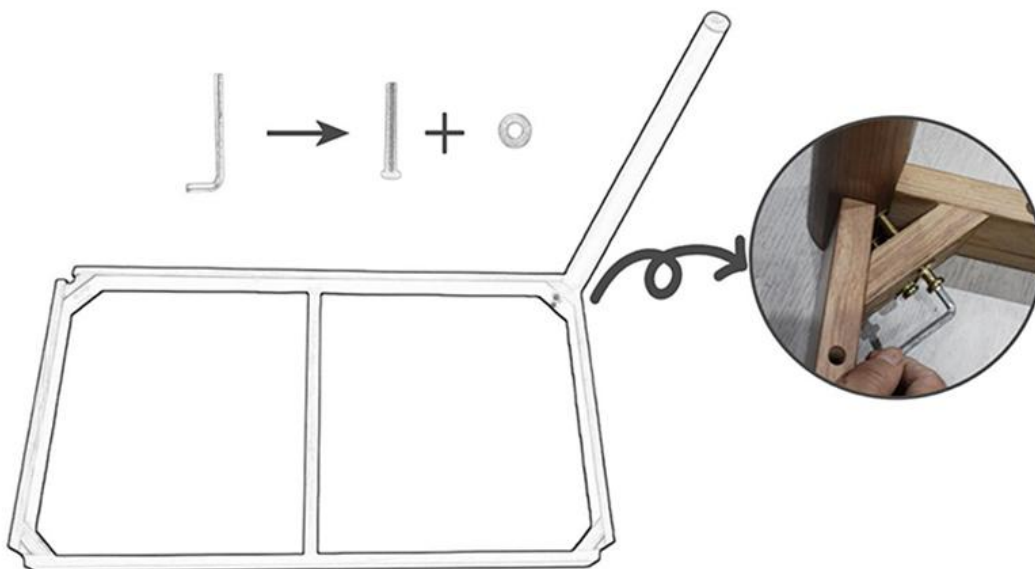

## Attach the Tabletop

---

- A. Carefully flip the assembled frame over so that it is upright.
- B. Place the tabletop on the frame, ensuring it is properly aligned.

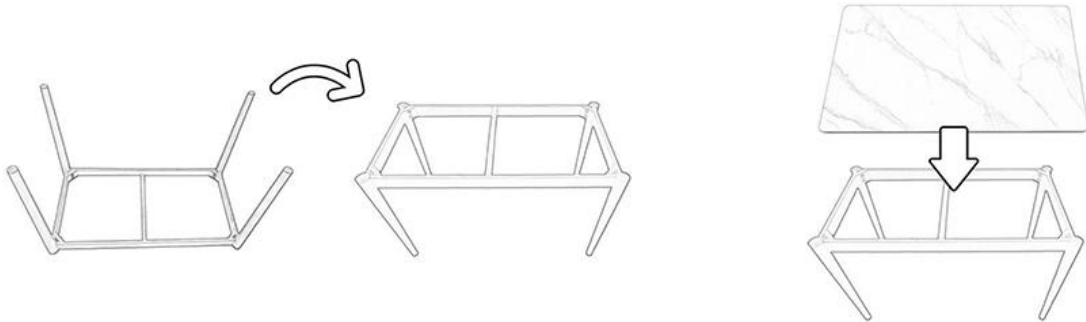

## Secure the Tabletop

---

- A. Position the angle brackets at suitable locations on the underside of the tabletop where it meets the frame.
- B. Use the self-tapping screws to attach the angle brackets to both the tabletop and the frame. Two angle brackets are required per edge.
- C. Ensure all brackets are securely fastened and the tabletop is firmly connected to the frame.

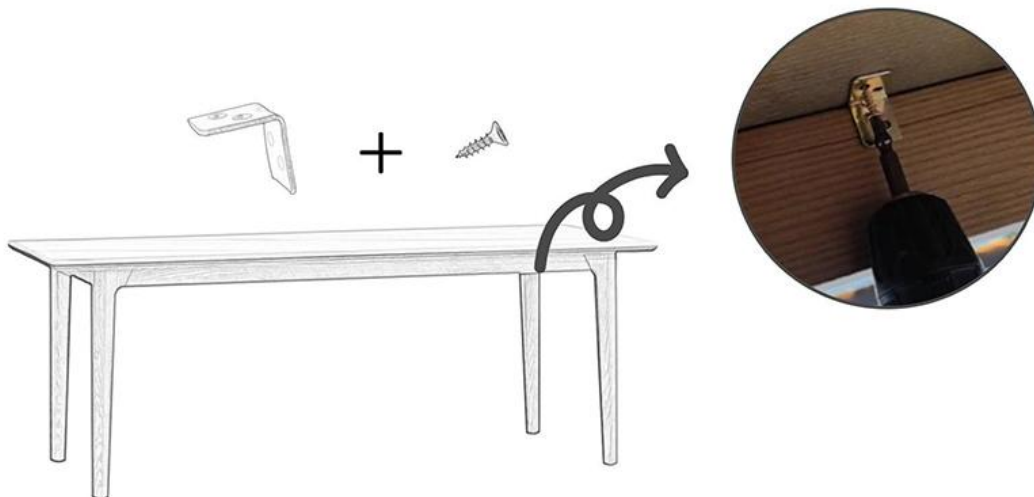

## Completion

---

Once all screws and brackets are properly installed, the assembly is complete. Check the stability of the table and make any necessary adjustments.

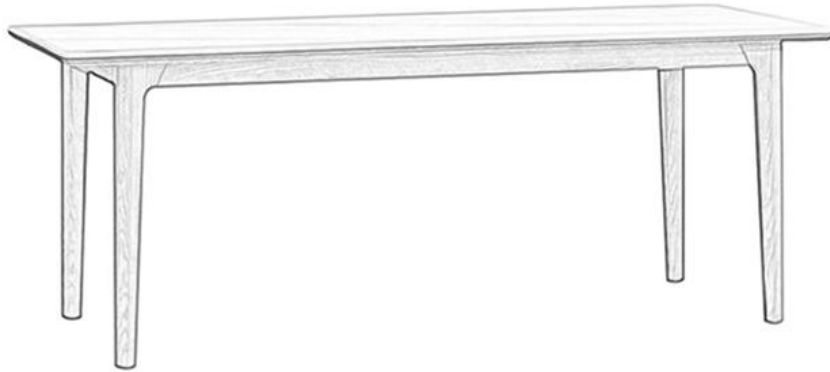

## 6 Safety Warnings:

### Assembly:

A. Ensure the table is assembled on a flat, stable surface to prevent accidental tipping or instability.

B. Use appropriate tools and follow the assembly instructions carefully to avoid injury or damage.

### Usage:

A. Do not overload the table with excessive weight, which could compromise its stability and structure.

B. Keep the table away from direct heat sources, such as stoves or heaters, to prevent potential damage to the materials.

### Children and Pets:

A. Keep small parts and assembly tools out of reach of children to prevent choking hazards or injuries.

B. Supervise children and pets around the table to avoid accidents or damage to the furniture.