

ASSEMBLY INSTRUCTIONS

VANITY SET WHITE

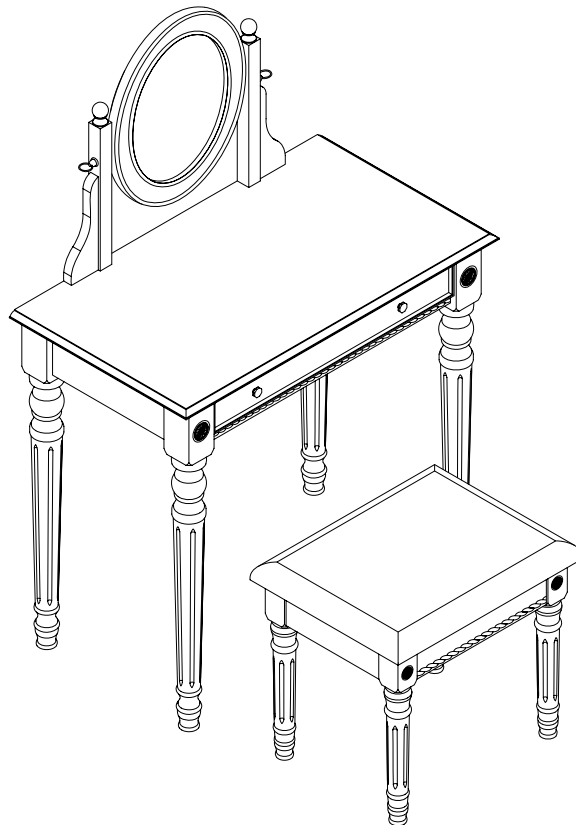









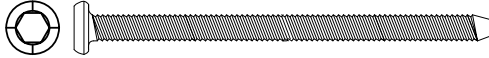

WE ARE HERE TO HELP!

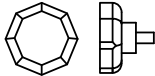
HARDWARE PACKAGE COUNT

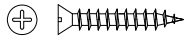
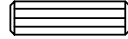
OPEN HARDWARE PACKAGE ON A FLAT SURFACE COVERED WITH NEWSPAPER. COUNT EACH PIECE OF HARDWARE TO MATCH THE QUANTITY NUMBER IN THE HARDWARE LIST COLUMN. CALL CUSTOMER SERVICE IF ANY OF THE PARTS ARE MISSING. FOLLOW THE LETTER IDENTIFICATION WHEN READING THE ASSEMBLY GRAPHICS "A" THROUGH "M".

HARDWARE IDENTIFICATION

CODE	GRAPHICS	DESCRIPTION	QTY
A	 Ø1/4xL.2-1/4"	MIDDLE BOLT	8
B		SPRING WASHER	8
C		FLAT WASHER	8
D		ALLEN KEY	1
E	 Ø1/4"xL.1"	SHORT BOLT	4
F		GLASS KNOB	2
G		KNOB SCREW	2
H	 Ø4x25mm	FLAT HEAD SCREW	8
I	 Ø8.8x25mm	WOOD DOWEL	4
K		LONG BOLT	2
L		METAL WASHER	2
M		PLASTIC WASHER	2

ALL PARTS ARE LABELED WITH STICKERS MATCHING THE PART IDENTIFICATION NUMBERS LISTED IN LEFT COLUMN.

IMPORTANT
PLEASE USE ALL THE HARDWARE MENTIONED ABOVE.
THEY WILL ASSURE THE ITEM STABILITY AND SAFETY.

TOOLS REQUIRED

A STANDARD PHILLIPS HEAD SCREWDRIVER (NOT PROVIDED) AND AN ALLEN WRENCH "D" (PROVIDED) ARE REQUIRED TO ASSEMBLE THIS UNIT. USE A PLASTIC HEAD MALLETT, NOT PROVIDED, TO TAP IN STRETCHERS OR OTHER COMPONENTS.

PART IDENTIFICATION:

CODE	DESCRIPTION	QTY
1	TABLE - TOP WITH FRAME	01
2	TABLE - BACK LEG	02
3	TABLE - FRONT LEFT LEG	01
4	TABLE - FRONT RIGHT LEG	01
5	MIRROR - OVAL FRAME	01
6	MIRROR - LEFT POST	01
7	MIRROR - RIGHT POST	01
8	STOOL - CUSHION	01
9	STOOL - FRAME	01
10	STOOL - LEG	04

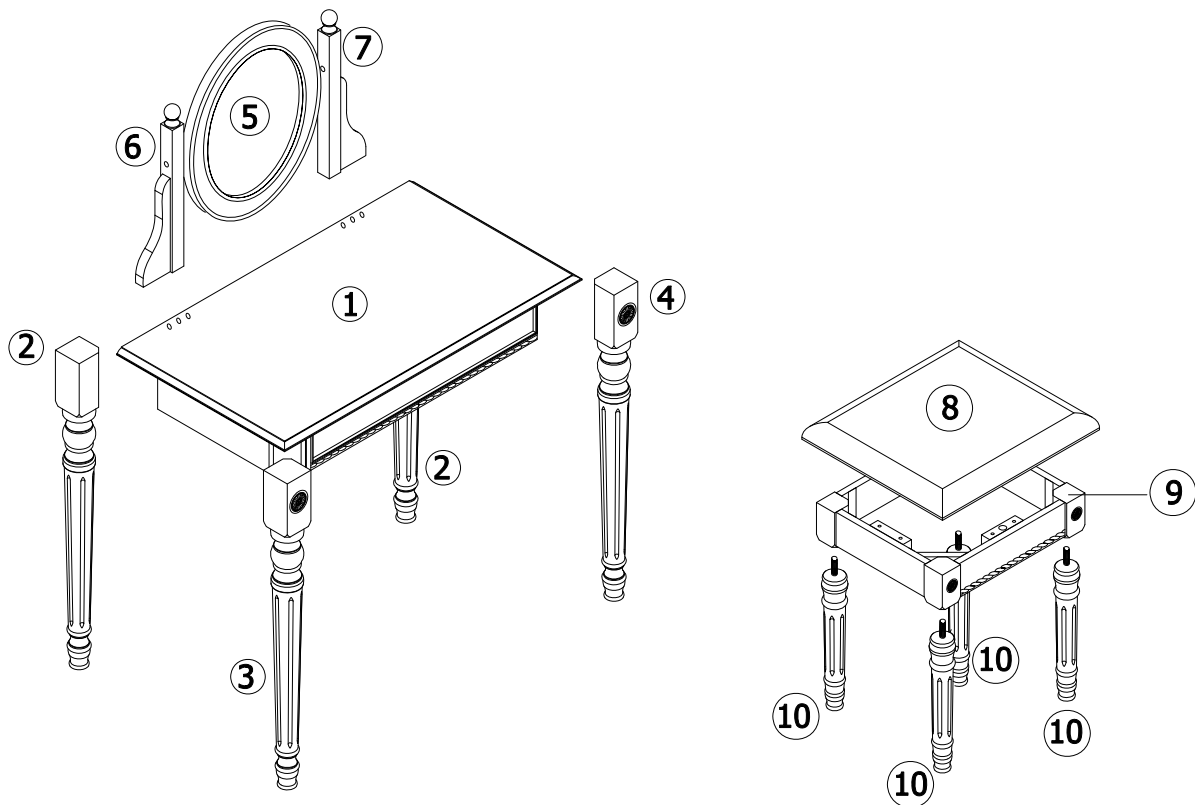

STEP 1:

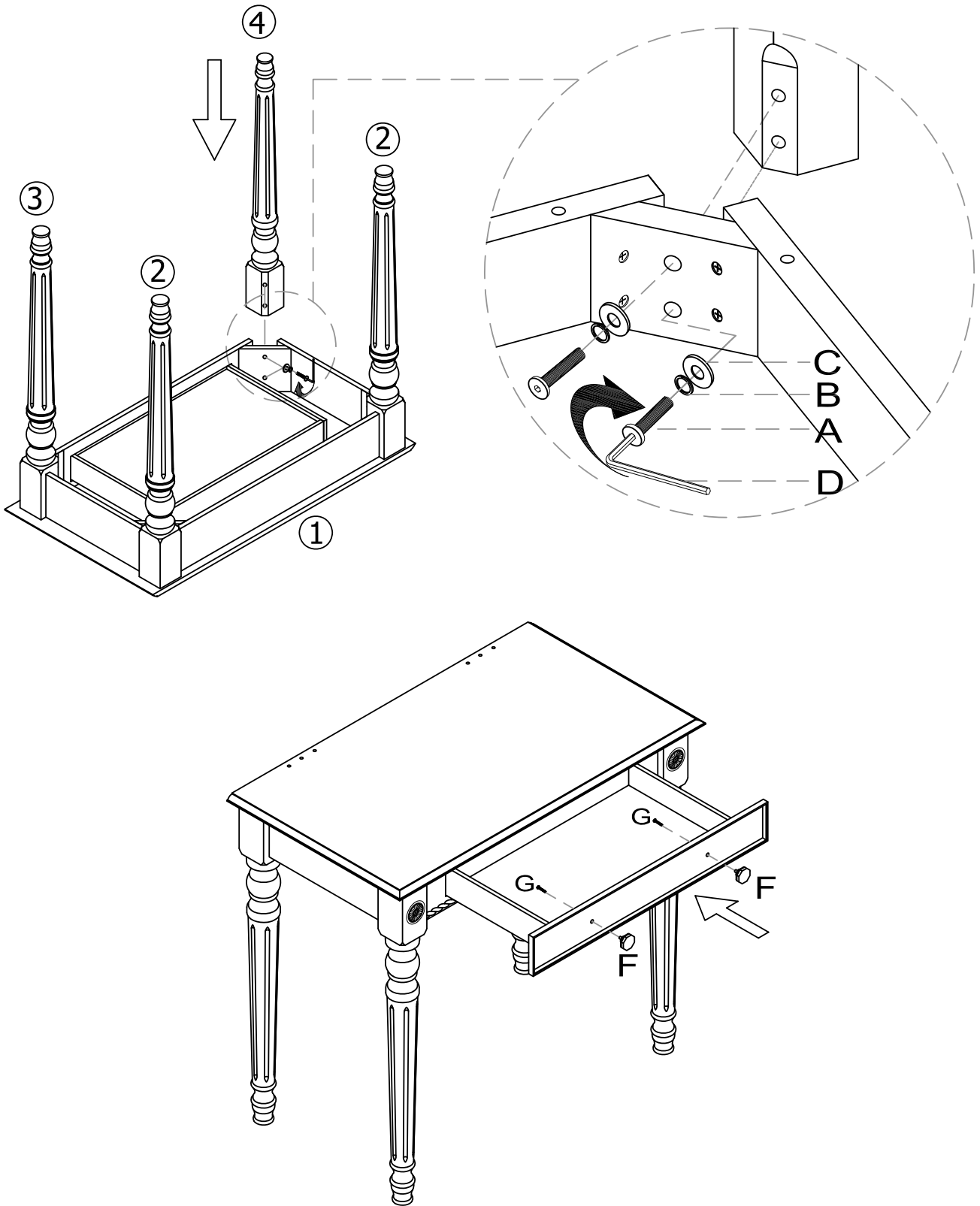

STEP 2:

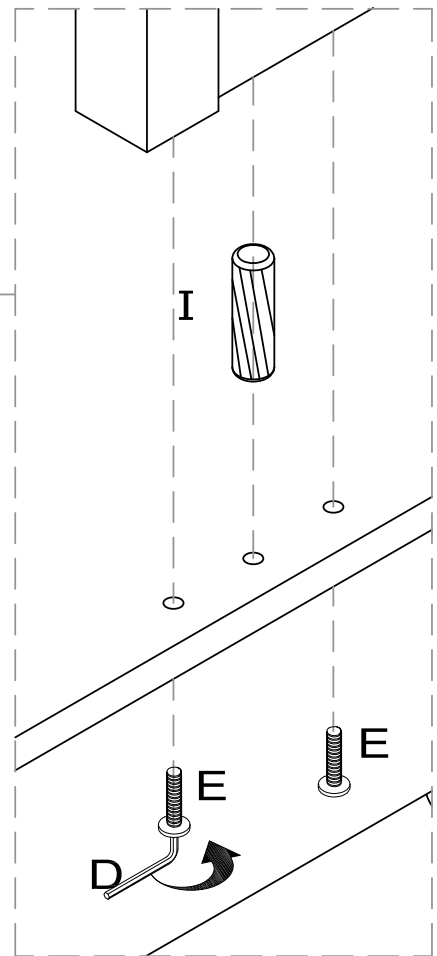
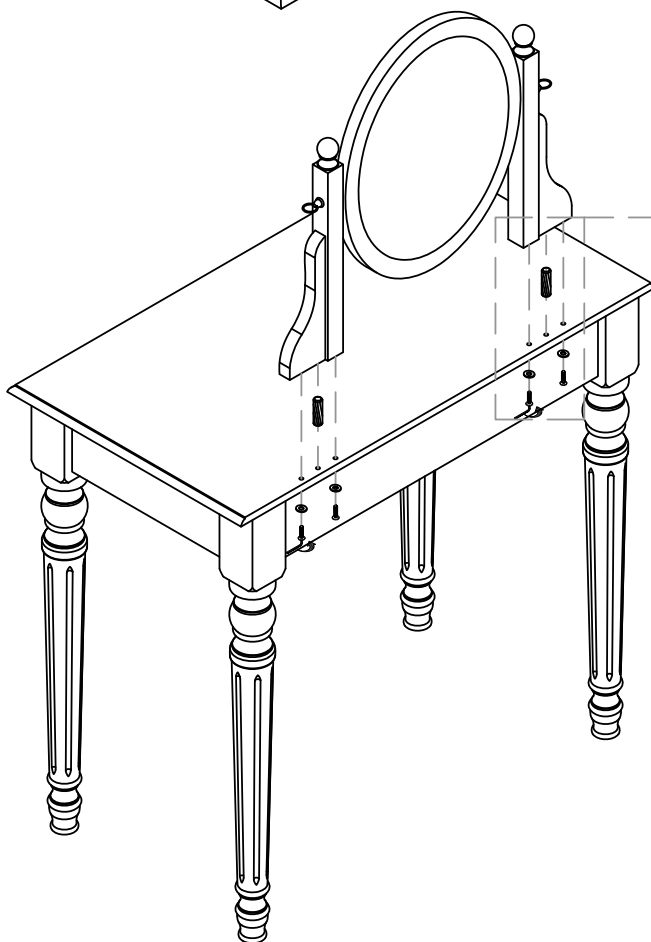
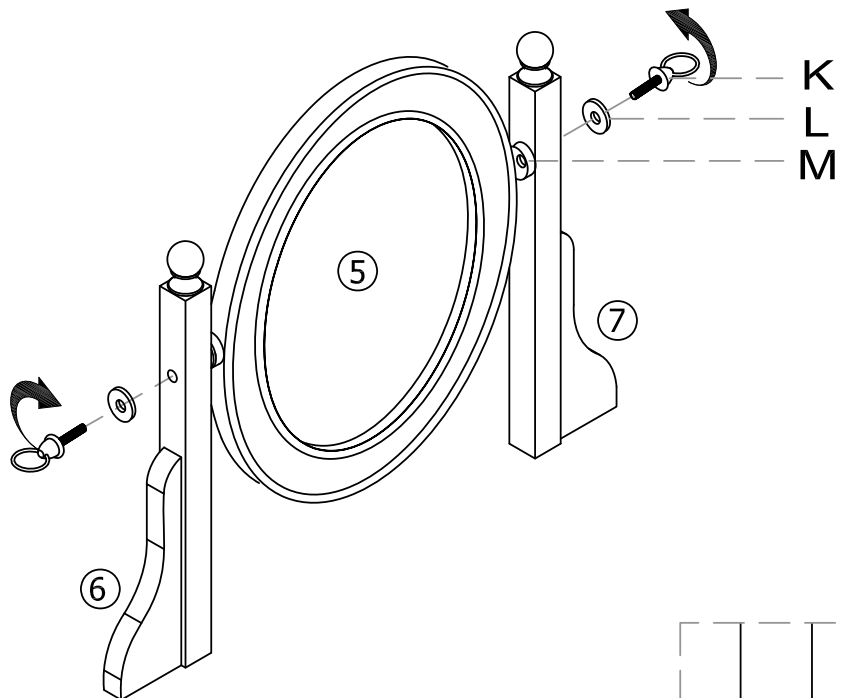

STEP 3:

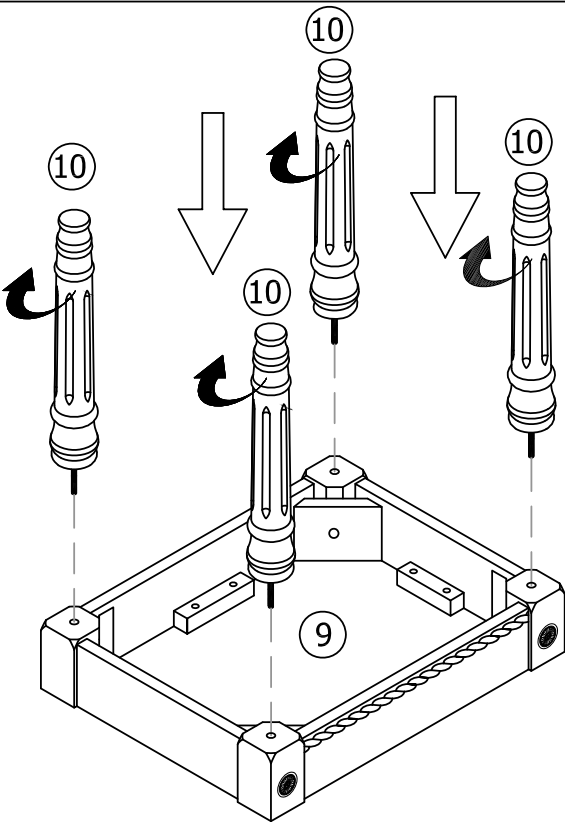

I

H

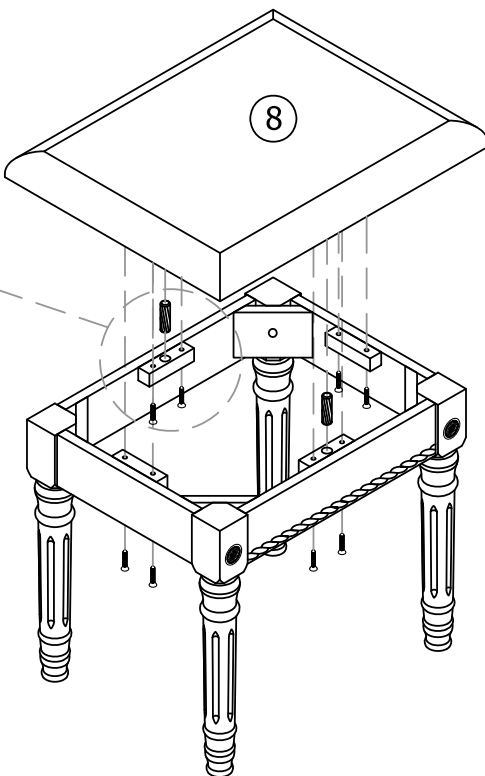
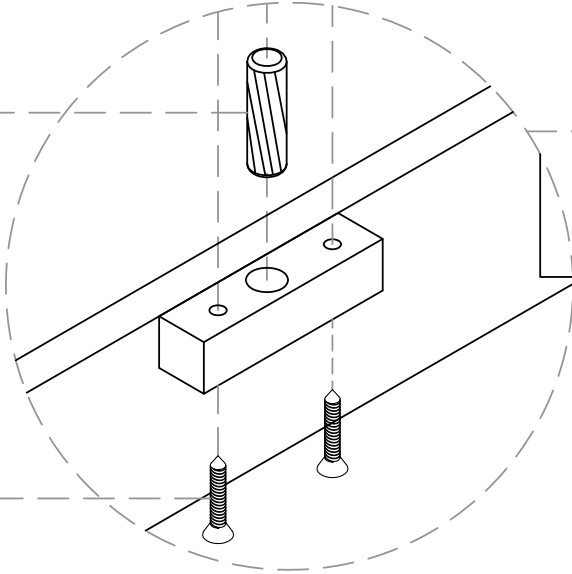

COMPLETED ASSEMBLY

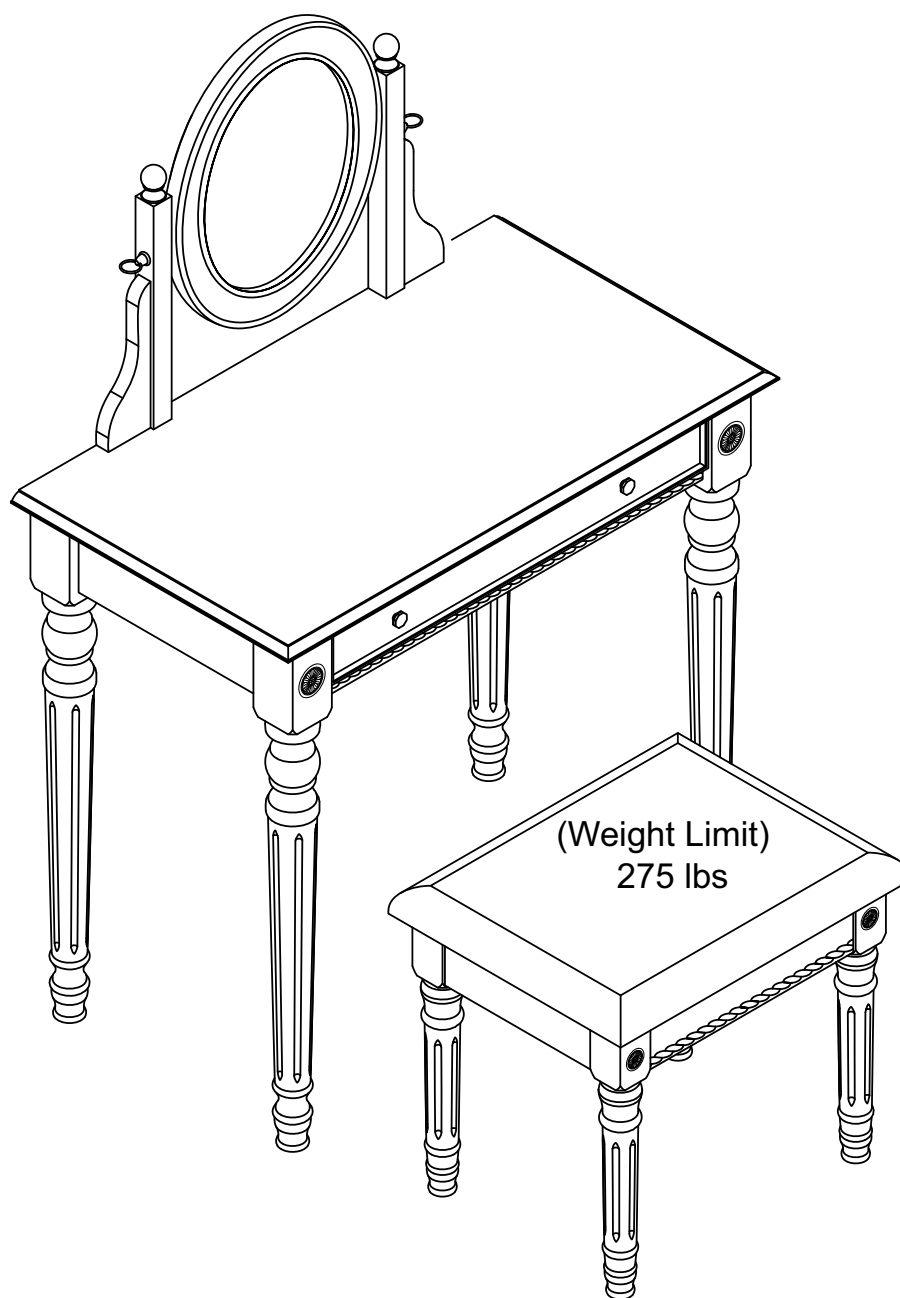

LIMITED WARRANTY
WHAT IS COVERED

WHAT IS NOT COVERED

HOW TO OBTAIN SERVICE