

LONG BENCH

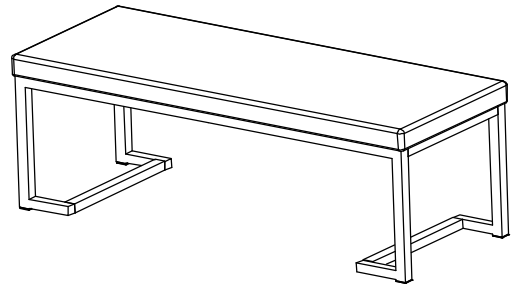
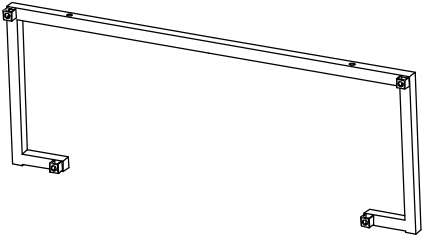
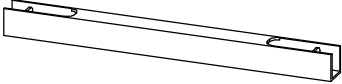
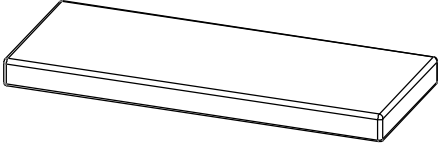
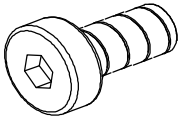
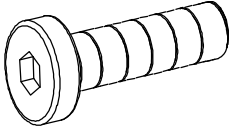
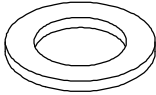
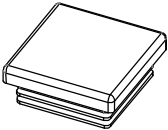
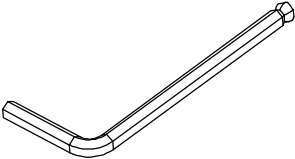

ASSEMBLY INSTRUCTIONS

1	2	3
 <p>SIDE FRAME 2PCS</p> <p>A</p>	 <p>STRETCHER 4PCS</p> <p>B</p>	 <p>CUSHION 1PC</p> <p>C</p>
 <p>BOLT 1/4\"X5/8\" 8PCS</p> <p>D</p>	 <p>BOLT 1/4\"X1-5/8\" 4PCS</p> <p>E</p>	 <p>WASHER 4PCS</p>
 <p>FOOT CAP 4PCS</p>	 <p>ALLEN KEY 1PC</p>	

***** Do not tighten screws & bolts until the entire unit is completely assembled. *****

STEP 1

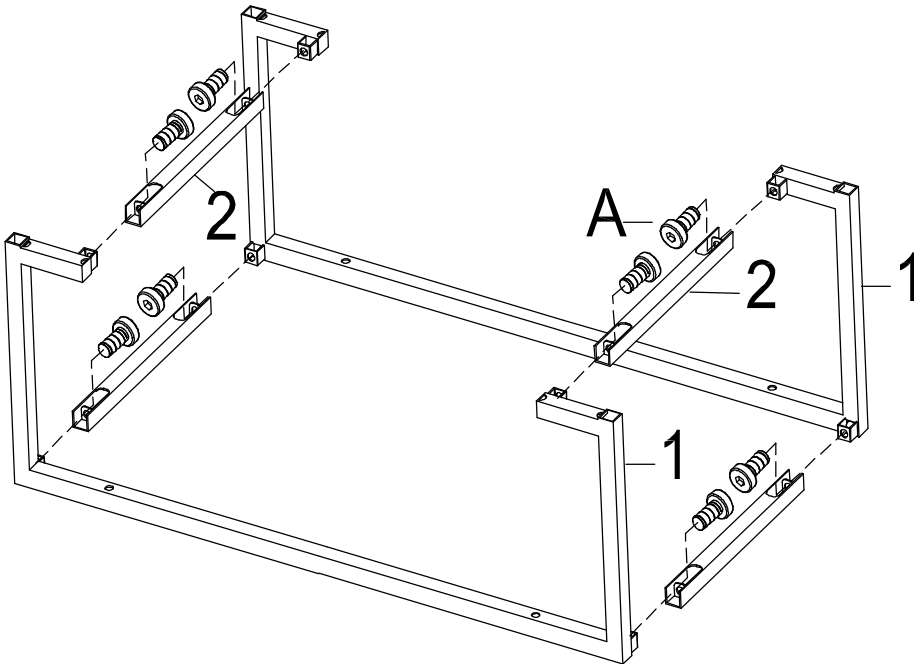

*Please put all parts on a soft surface to prevent scratches.

Attach stretcher (2) to side frame (1) by using bolt (A) as shown.

STEP 2

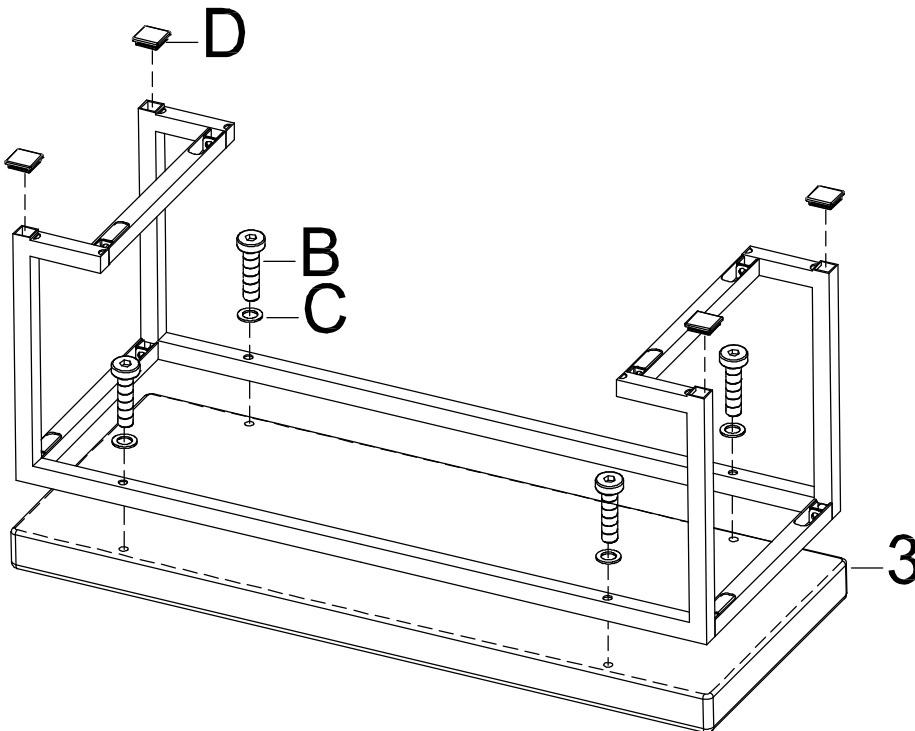

Attach metal frame unit to cushion (3) by using bolt (B) and washer (C) as shown and then insert foot cap (D) into the end of side frame.

Tighten all bolts firmly and turn the bench upright.

Your long bench is now complete.