

New Working New Living

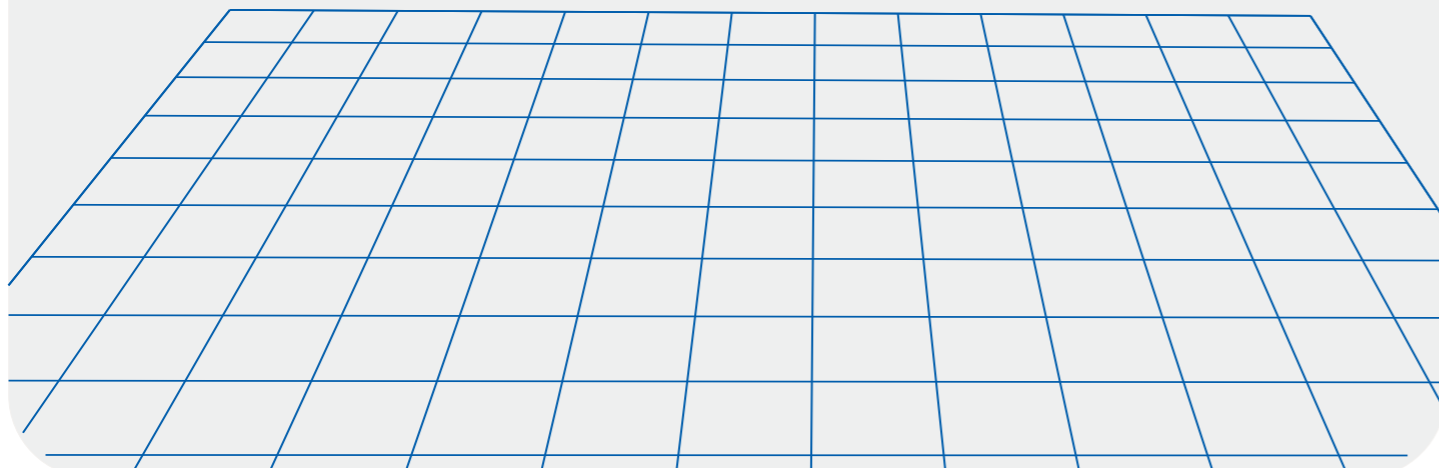

+1 (855) 585-5618



FlexiSpot

User Manual

Item No. EN2-4024/EN2-4824

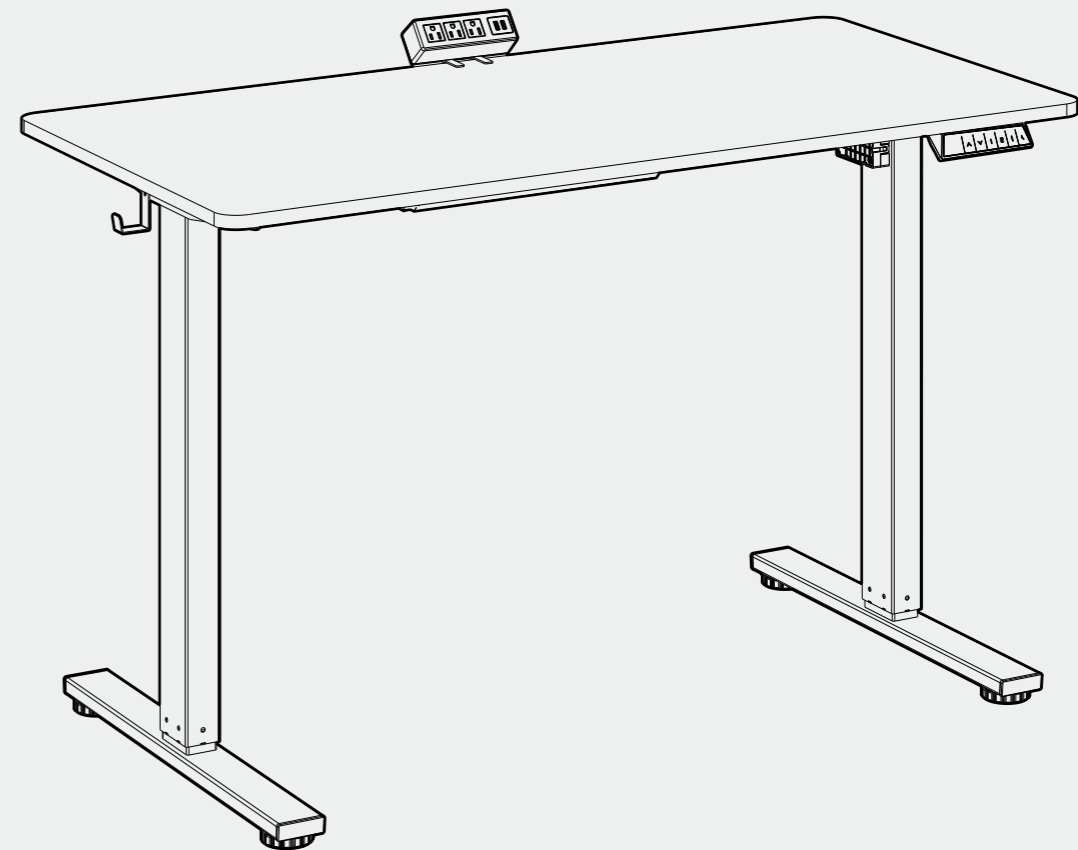

Specifications

Column No.	2
Max. Weight Capacity	154 lbs (Including hooks, with a hook load capacity of 11 lbs)
Max Speed	0.6"/s
Height Range (Min to Max)	28.9"-46.5"
Desktop Size (EN2-4024)	39.4"x23.6"x0.6"
Desktop Size (EN2-4824)	47.2"x23.6"x0.6"

Assembly Notes

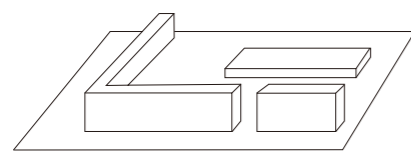

Assemble on carpet to prevent scratches

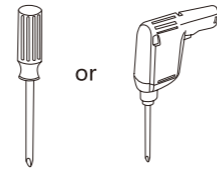

Phillips screwdriver or drill required (not provided)

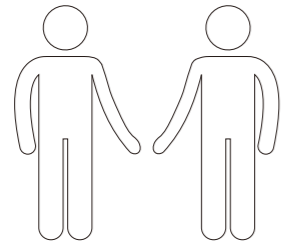

Cooperative assembly





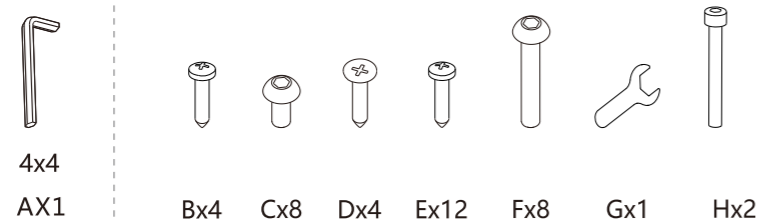

Product List





Accessory Package

Note: The following line drawings are for reference only and in some cases may be different from the actual part; please refer to the actual part. If you find missing parts or have installation problems, please contact customer service.

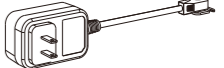

Parts Included

No.	Part
①	Desk board x1 
②	Supporting plate x2 
③	Crossbeam x1 
④	Right lifting column x1 
⑤	Left lifting column x1 
⑥	Transmission rod x1 
⑦	Motor with keypad x1 

No.	Part
⑧	Hook x2 
⑨	Desk foot x2 
⑩	Cable tie x4 
⑪	Power plug x1 
⑫	Power strip x1 
⑬	Cable management tray x1 

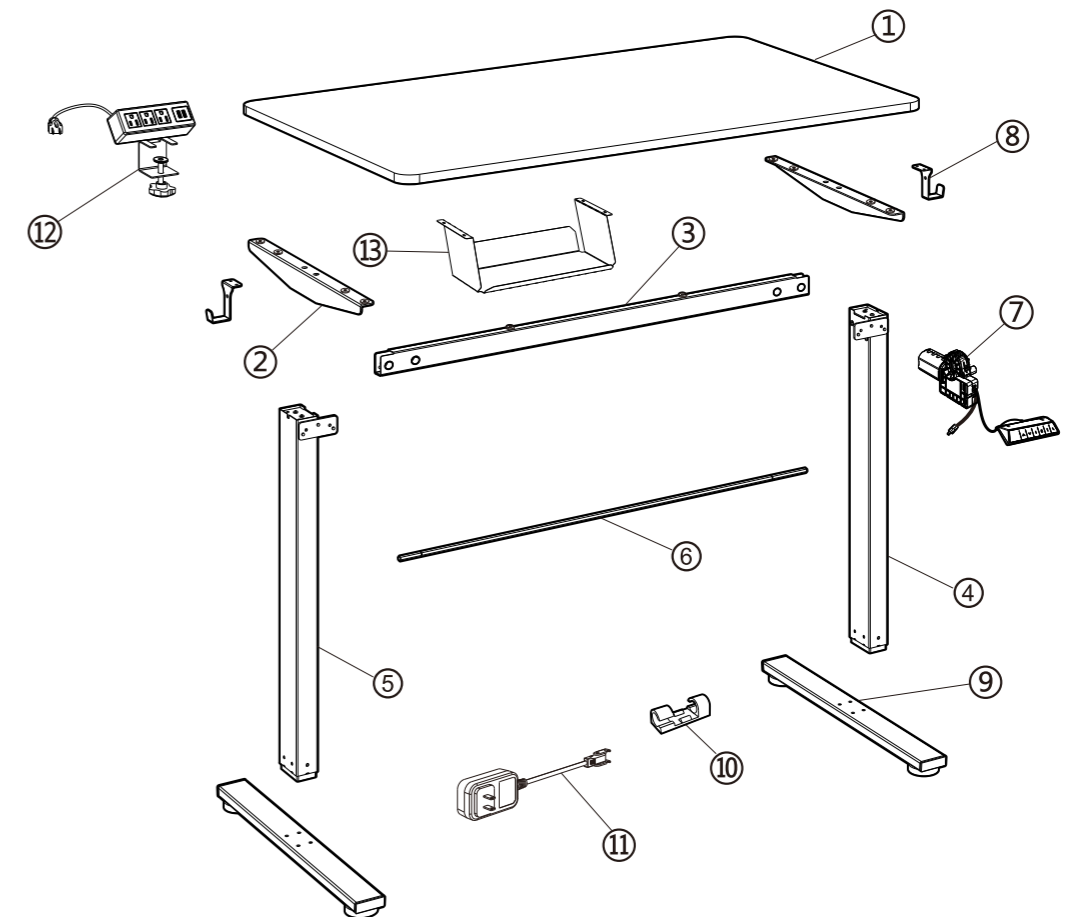

1 Insert the transmission rod into the motor

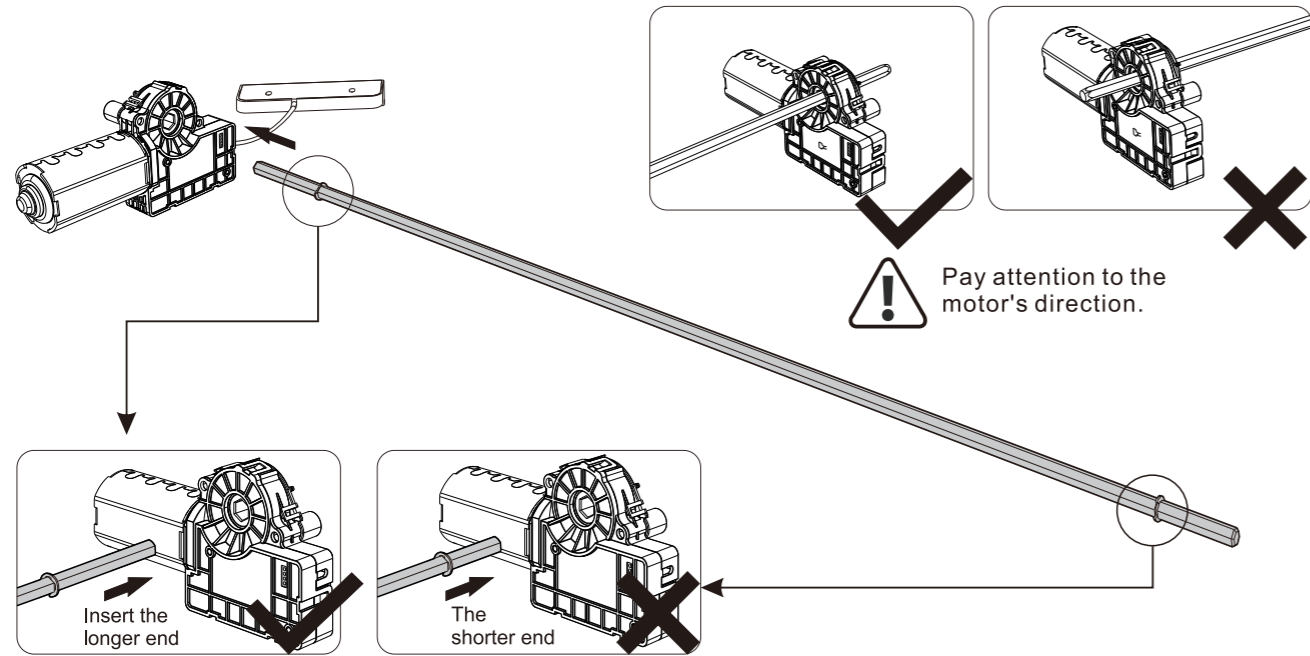

2 Install the motor and the right lifting column

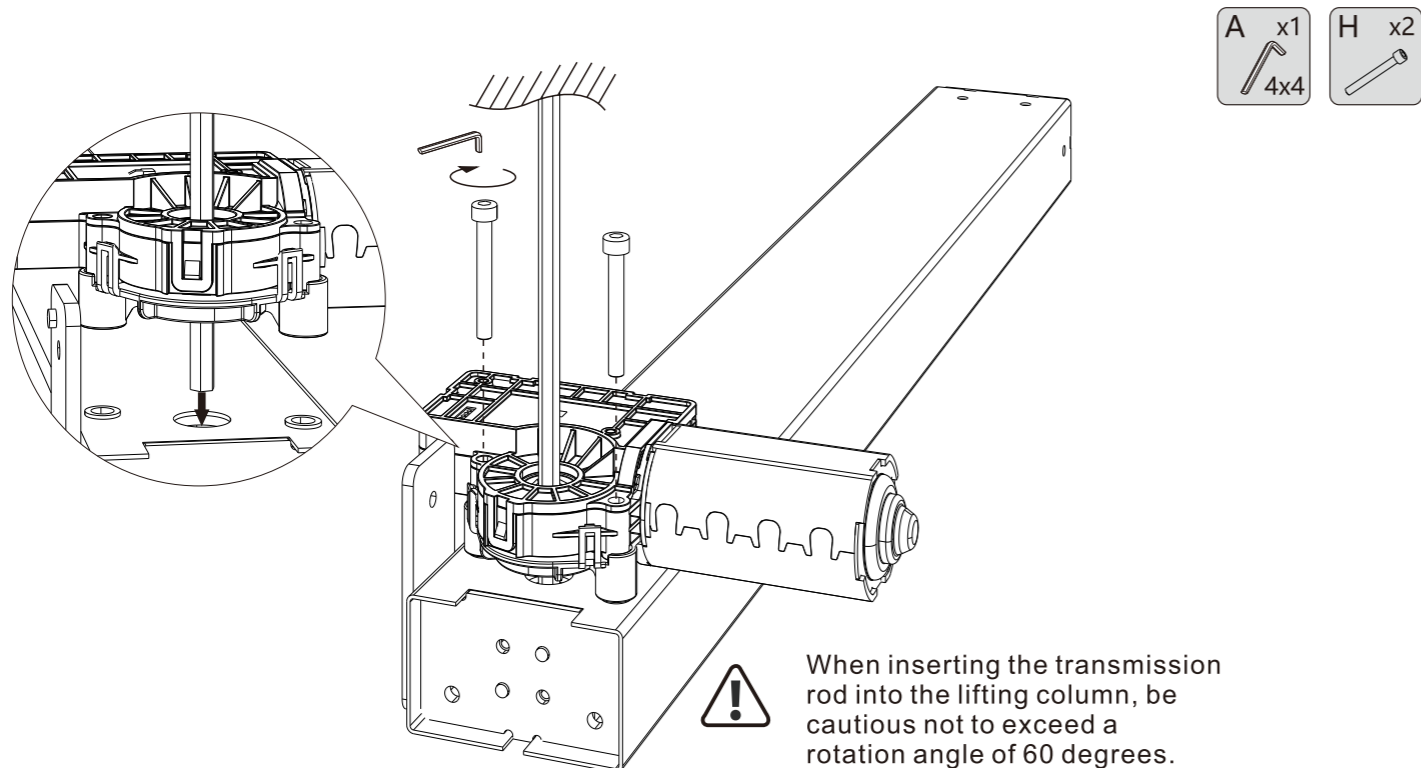

3 Install the crossbeam

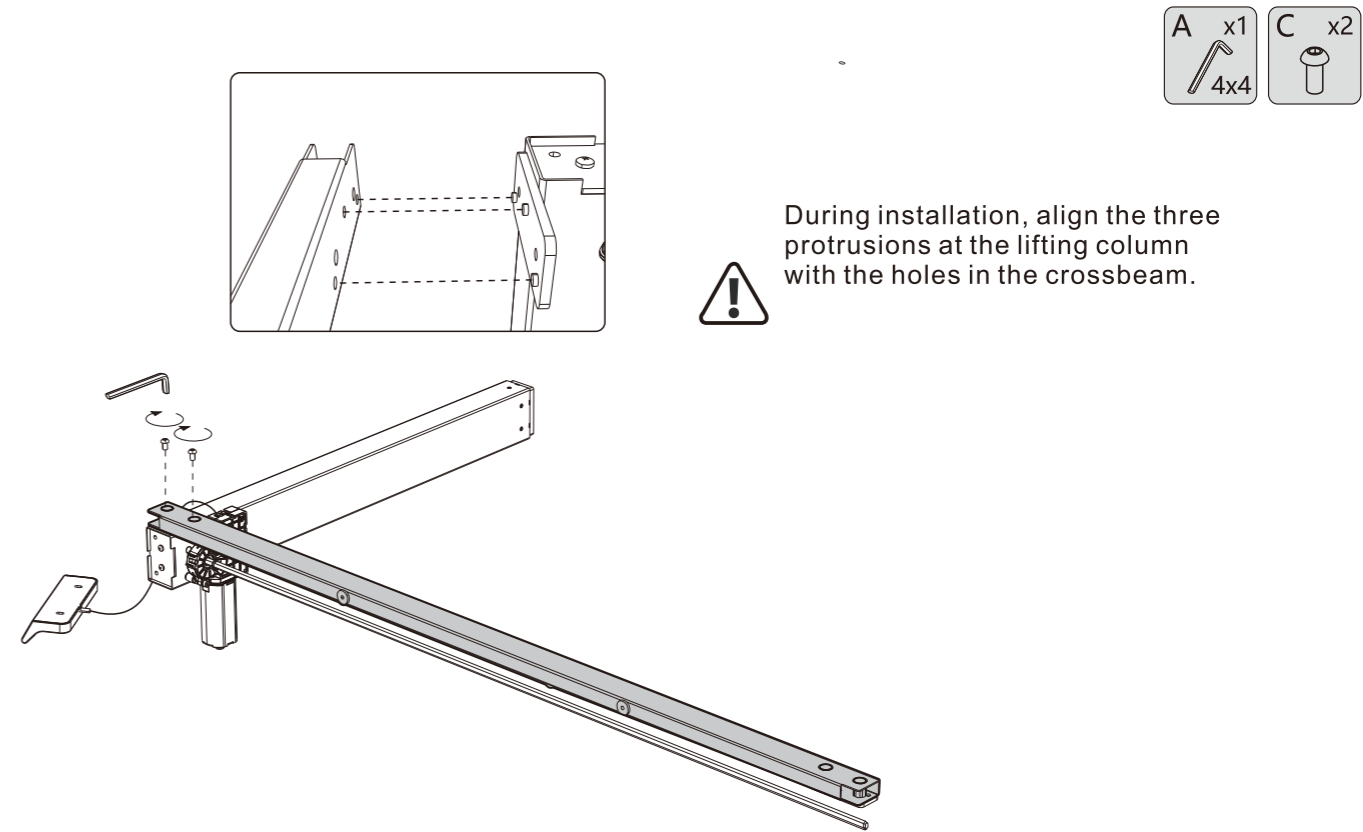

4 Adjust the height of the left and right columns

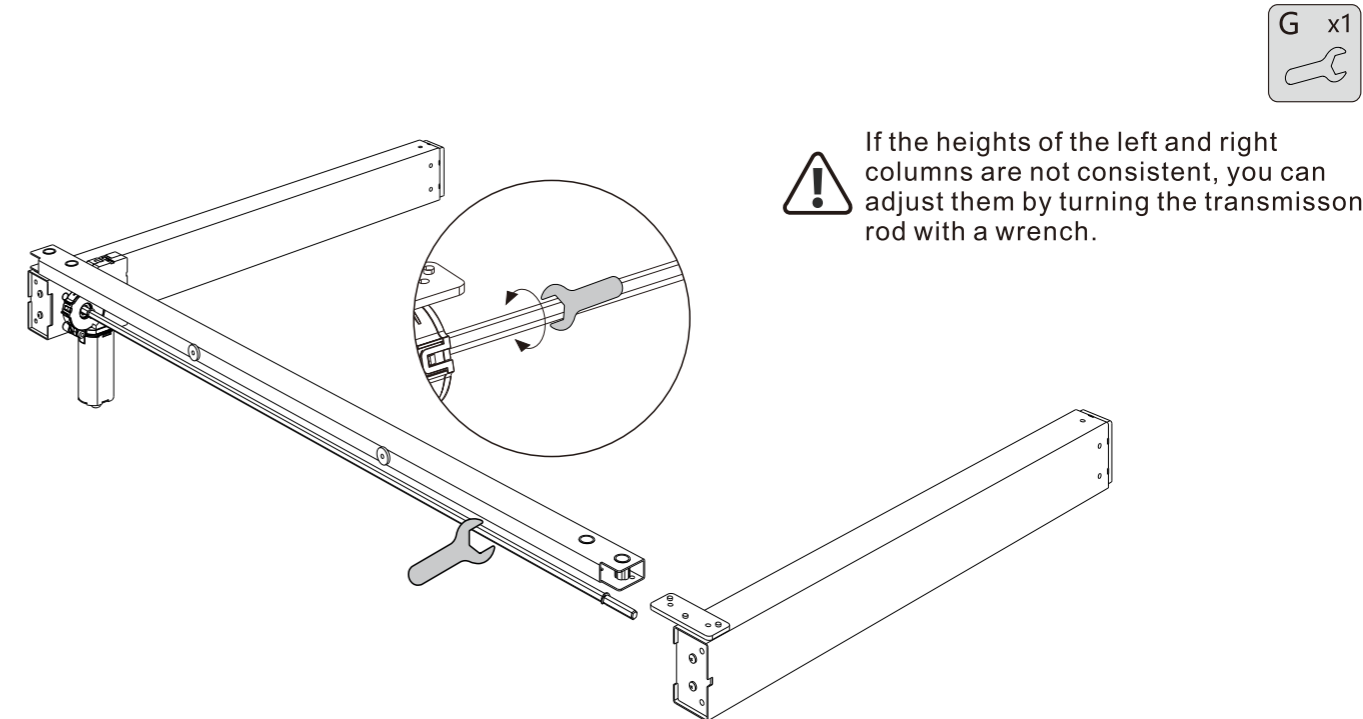

5 Install the Left lifting column

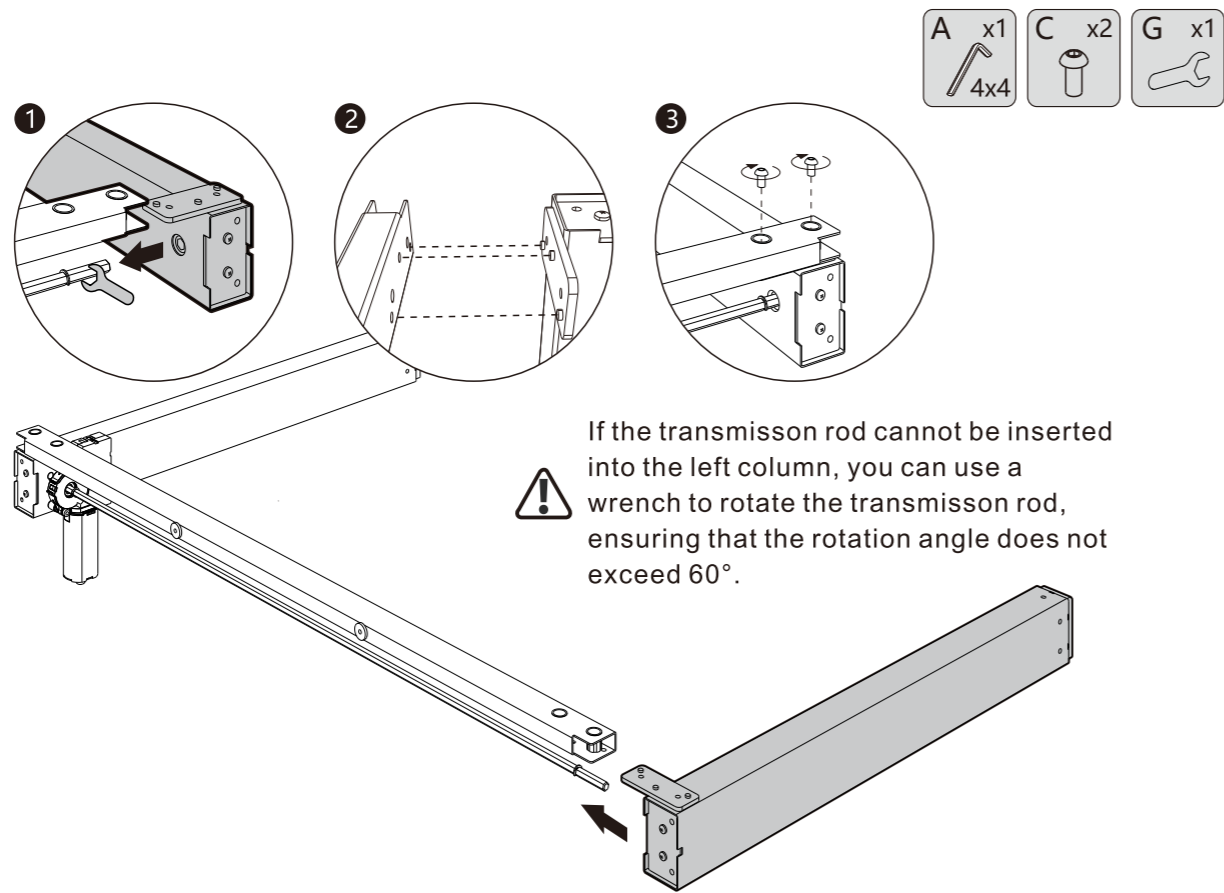

6 Install the supporting plates

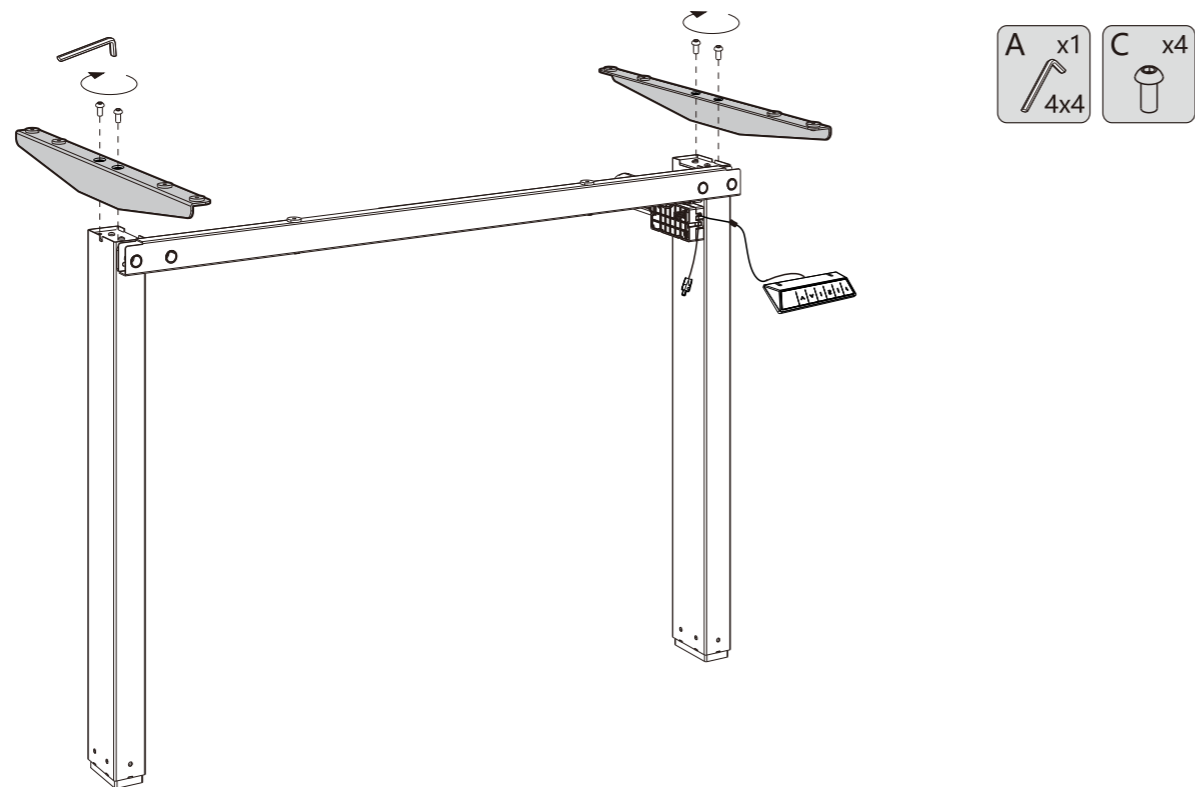

7 Install the desk foot

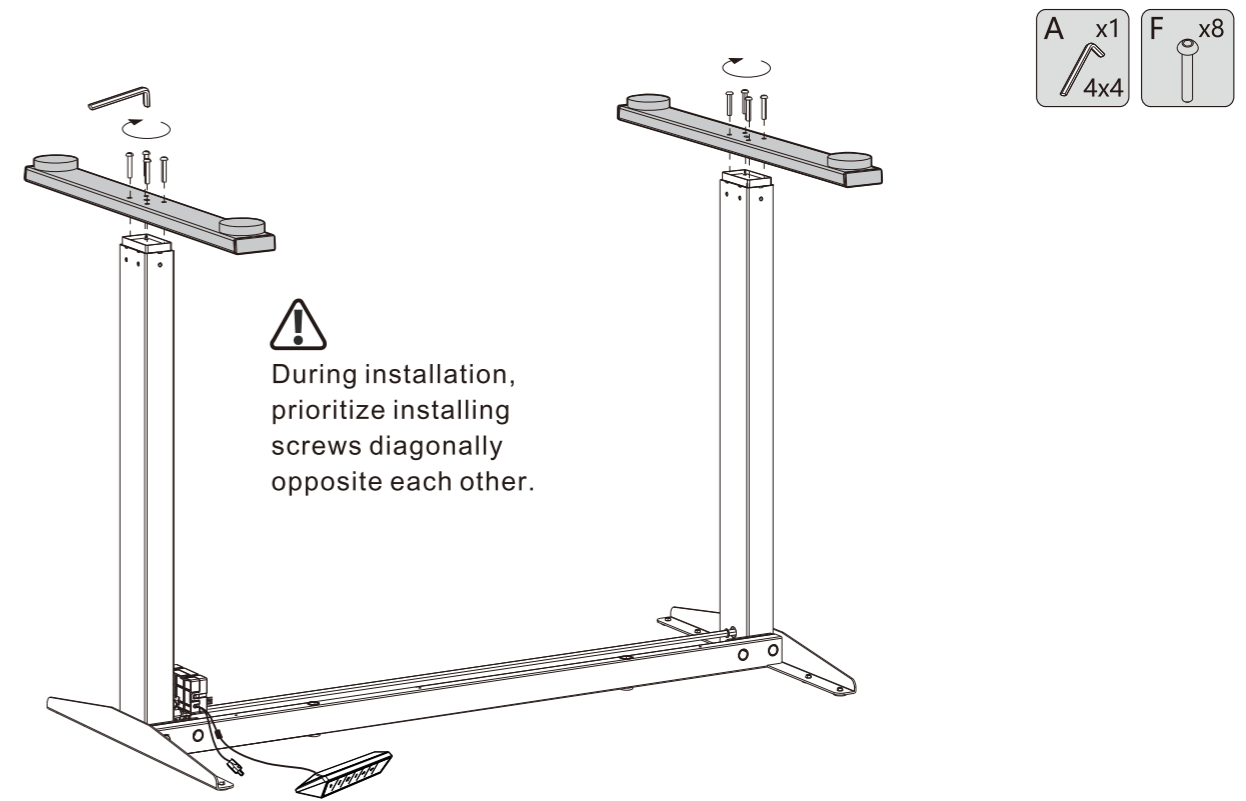

8 Install the desk board

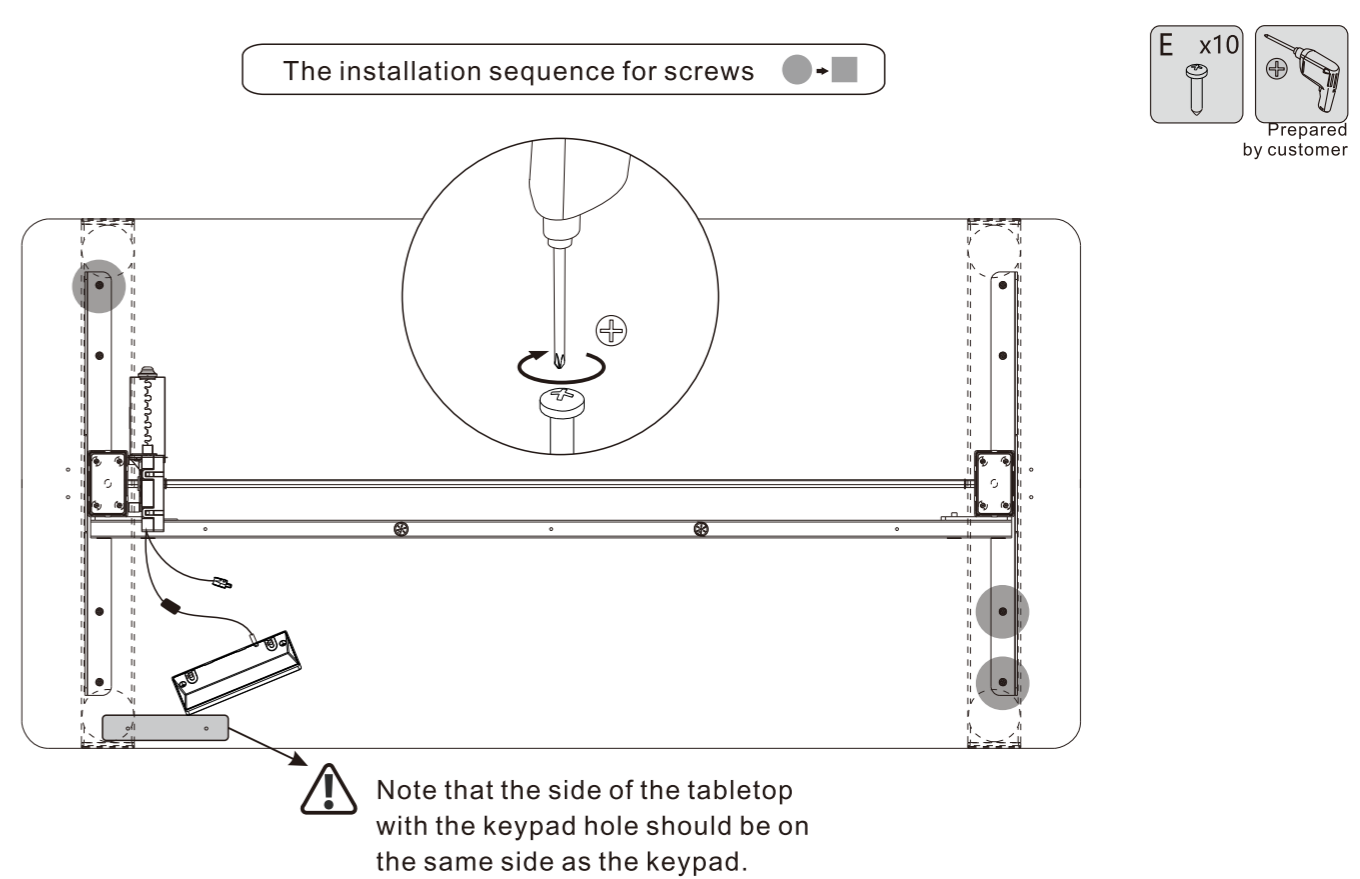

9 Install the keypad

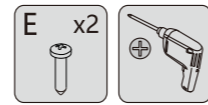
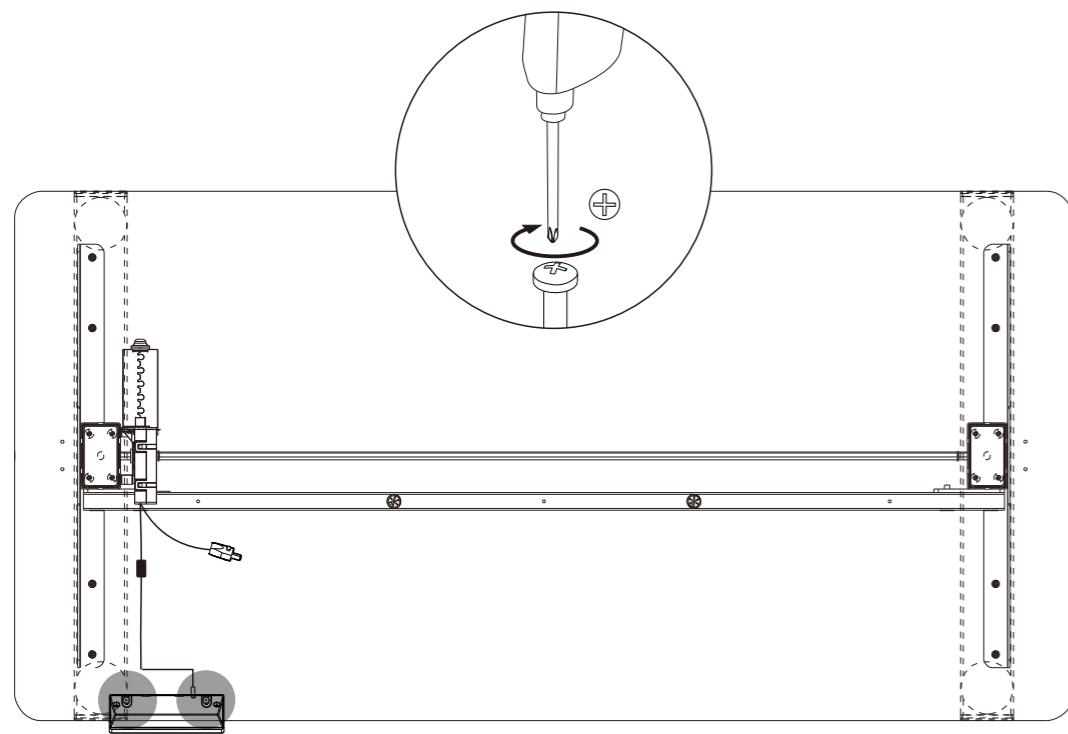

Prepared by customer

11 Fold cable management tray

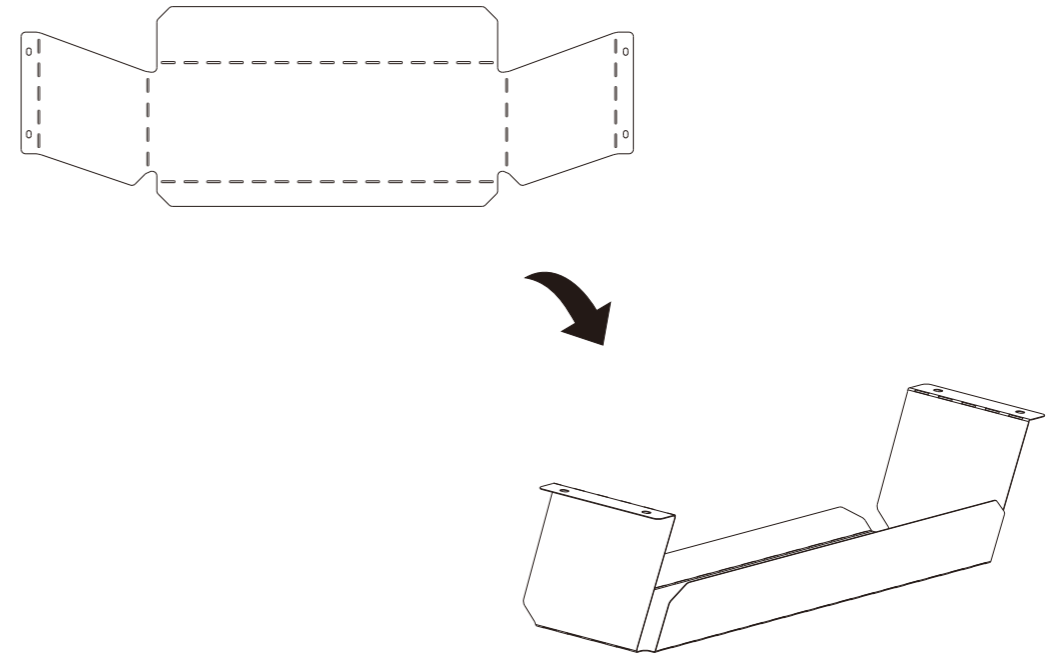

10 Install the hook

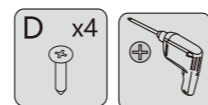
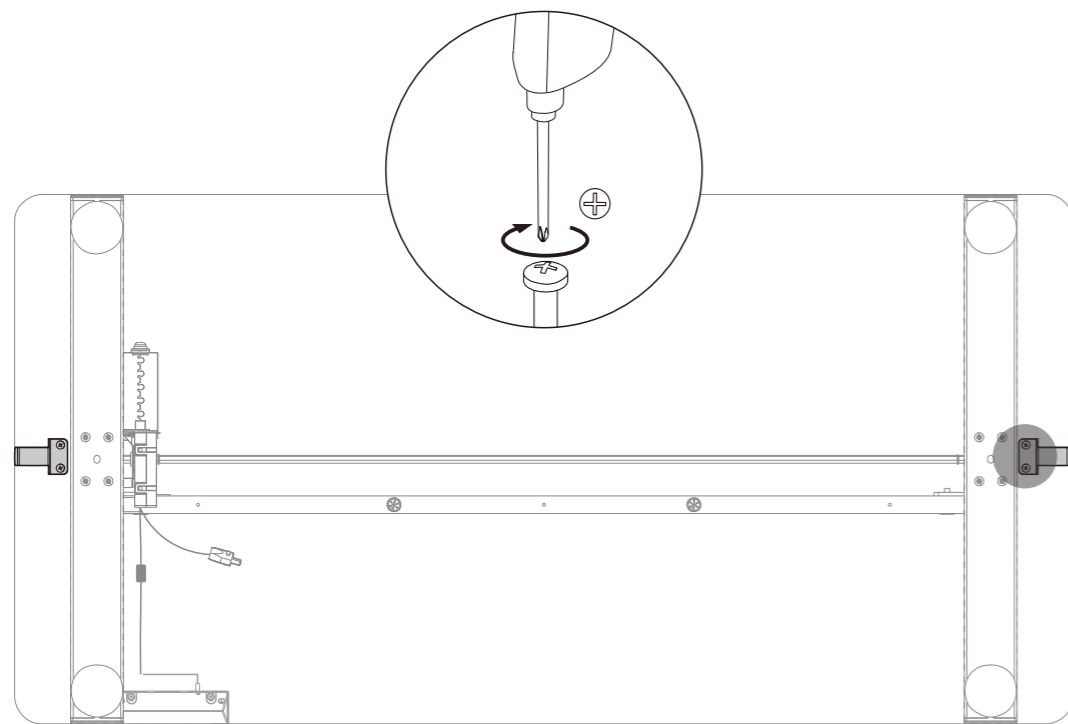

Prepared by customer

12 Install cable management tray

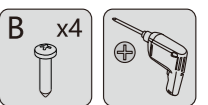
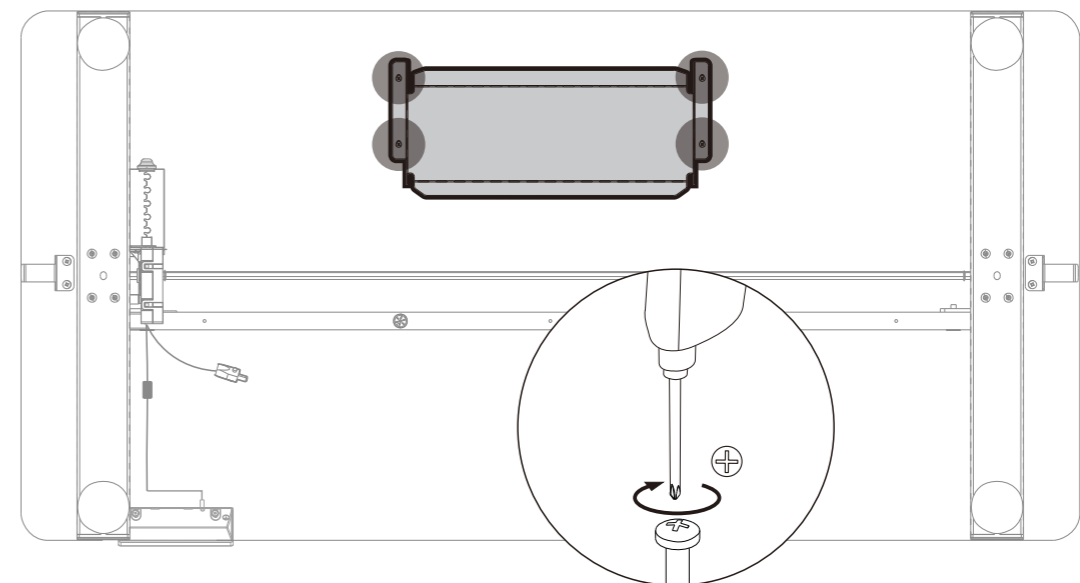

Prepared by customer

13 Wiring

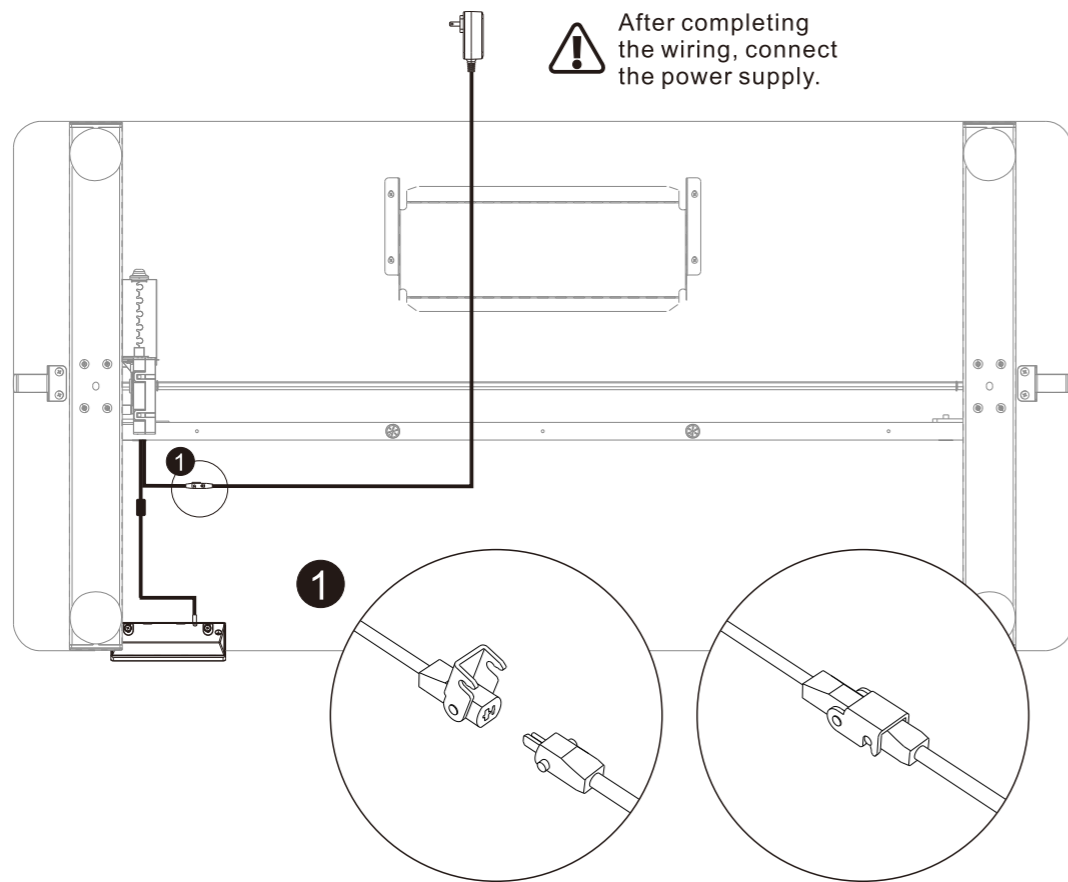

Use cable ties to secure each connection line to the desk board, keeping the cables tidy.

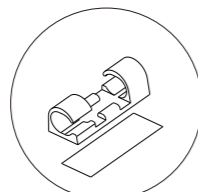

Open up

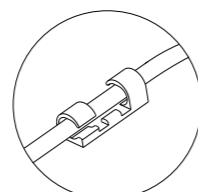

Sort out cords

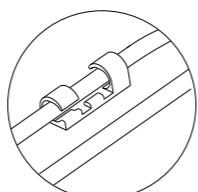

Buckle up

14 Flip the desk

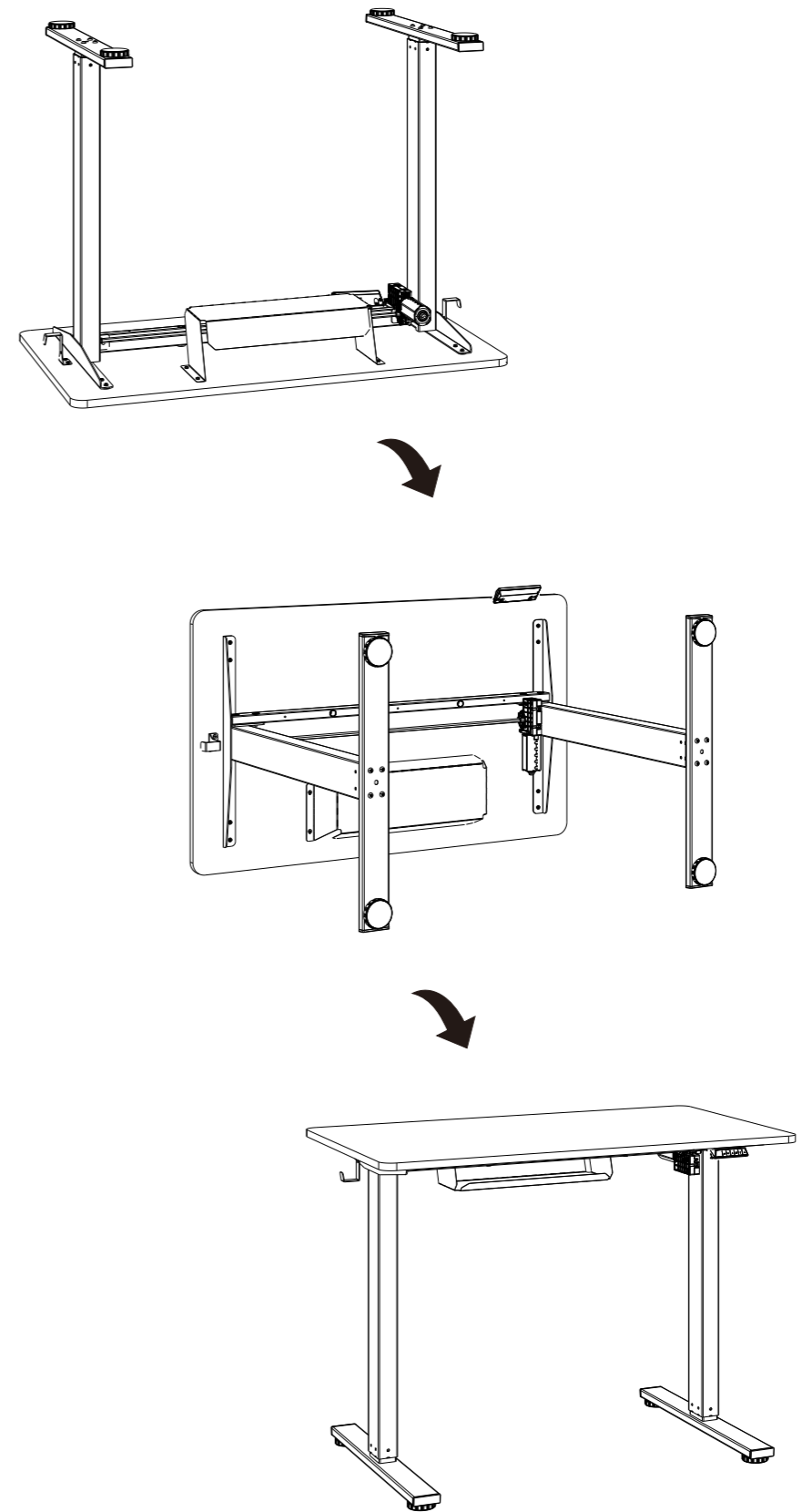

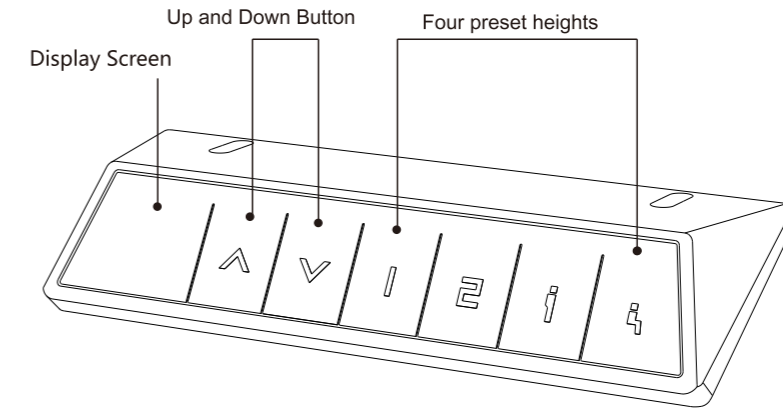
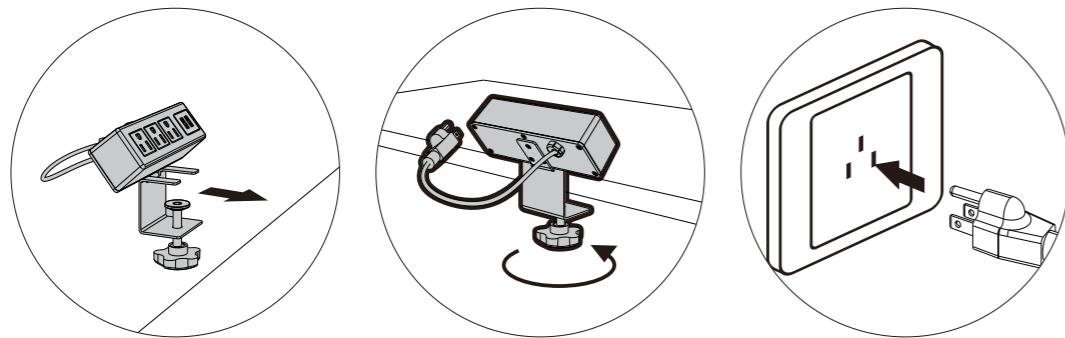
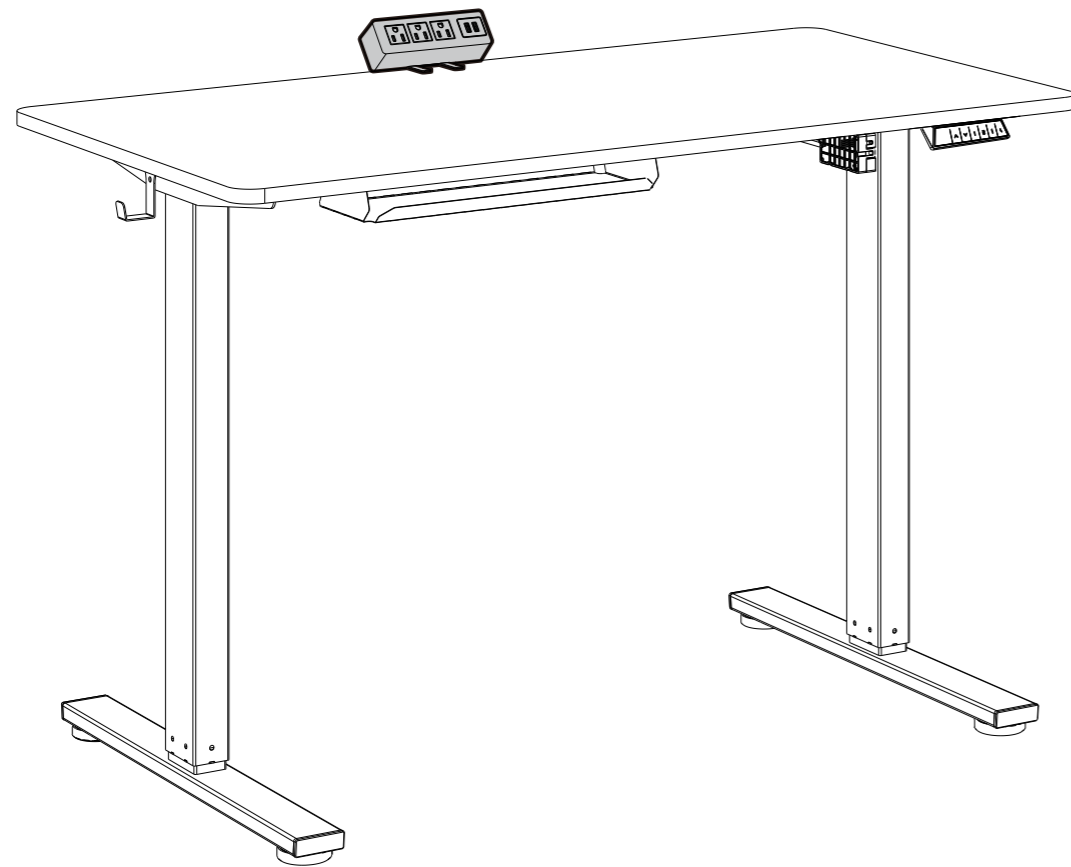

Note

During the desk's lifting, ensure there are no obstacles blocking its movement, and all cable lengths are sufficient for the desk to move up and down.

Suggestion

Preset the most comfortable height while standing as "1", and the most comfortable height while sitting as "4"; other preset heights can be freely set to different levels.



Height Adjustment Buttons:

Use the "∧" or "∨" buttons to adjust the table height up or down, and the current height is displayed on the screen.

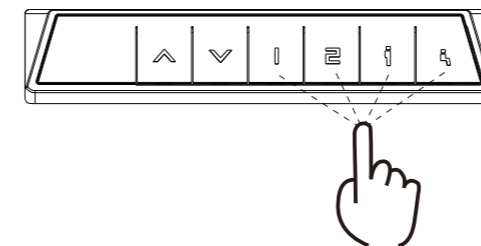

Height Memory Function:

A. In the stationary state of the desk, press and hold the "1" button for 3 seconds. The screen will display "5-1", indicating successful memory of the current height. To automatically run the desk to the memorized height, simply press the "1" button after adjusting the desk to any height.
 B. The "2", "3", and "4" buttons also have the same height memory function as the "1" button. Repeat the above steps to save the corresponding height in memory, and press the button again to automatically run to the memorized height.



Sensitivity Adjustment for Anti-collision:

A. There are four sensitivity levels. When the lift system encounters an obstacle, this function is triggered to protect against retraction.
 B. Simultaneously press and hold the "∧" and "∨" buttons for 3 seconds to switch sensitivity levels. Each operation switches one level, with four levels: A-0, A-1, A-2, A-3.
 C. The screen displays "R-0" to turn off the anti-collision function; "R-1" for low sensitivity; "R-2" for medium sensitivity; "R-3" for high sensitivity.
 D. When encountering obstacles during lifting, it will immediately retract, serving as a protective measure.



Reset Function:

A. Specific reset operations:

Method 1:

Hold the "v" down button until the desk descends to the lowest position, then release the button. Next, long-press the "v" down button until the screen shows the current height, then release the "v" down button to complete the reset.

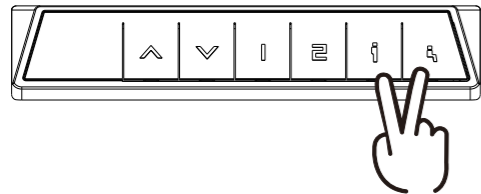

Method 2:

Simultaneously press and hold the "f" and "i" buttons for 3 seconds to view the software version of the entire system. After viewing, continue to press and hold the "f" and "i" buttons. When the LED display shows "r5t", release the buttons. This enters the reset state. Long-press the "v" down button until the screen displays the current height, then release the "v" down button to complete the reset.

B. In case of a malfunction in the lift system, hold the "v" down button until the desk descends to the lowest position, then release the button. Next, long-press the "v" down button until the screen shows the current height, then release the "v" down button to complete the reset.

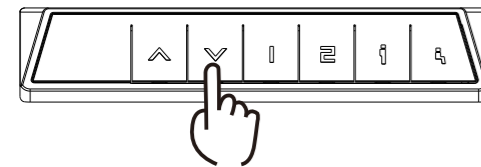

Code Handling:

- A. The reset function is defined, and the LED screen displays "r5t". Hold down the "v" button until the screen shows the current height, then release the "v" button to end the reset, and the table can be used normally.
- B. If "E01" or "E02" appears, let the table rest for at least 18 minutes to resume normal operation.
- C. If other codes appear and there is no response when holding down the "v" button, please check that the connection lines are intact and properly connected.
- D. Power off for more than 10 seconds, then reconnect the power, displaying "r5t", then long-press the "v" button to reset.

Resolving Common Issues

The following tips will help you identify and correct common issues. If you encounter an issue not listed in the table below, or if you follow the instructions below and the issue is still not resolved, please contact your supplier. All such anomalies or errors can only be investigated and corrected by the manufacturer or specially trained personnel.

Abnormal Phenomenon	Handling Method
Electronic functions fail	Check if the connection lines are properly connected
Slow ascent speed	Check if the equipment load exceeds 154 lbs.
Downward sliding	
Frequently enters reset state	
Only descends or only ascends	Perform a reset operation.
Insufficient ascent and descent heights	
The motor not move as instructed	
Overwork (Duty cycle: Max 2min on/18min OFF)	Power off for 18 minutes and then reconnect.
Pressing the down button results in ascen	Check for obstacles or hanging cables under the table.

Attention



- Power supply: AC100 - 240 V, frequency 50/60HZ;
- Working environment: 32°F - 104°F;
- Before cleaning, you have to unplug the power supply cable. Clean with a slightly damp cloth to wipe away the surface dust. Keep all electrical components away from liquids. Do not damage the connection line and keep the plug in a safe position.
- Inside the control box, there are electronic components, metal parts, plastic parts, wires and so on. They should be disposed in accordance with the local laws and regulations. They cannot be disposed as household waste.
- Before using the product, please make sure the product has been installed correctly.
- Before starting use of the product, please read the instructions to fully understand all the product's functions and settings.
- Keep children away from electric height-adjustable desks, control units and handsets. Manufacturer is not responsible of any damages that result from children's unpredictable behaviour.
- Slight noise caused by the multi wedge belt or brake system will not impact the use of this product.
- Do not use corrosive or abrasive materials to clean this product and please dispose of cleaning solutions in an environmentally friendly manner.
- Understand the risks associated with using this product. Children or those with cognitive impairment should not use this product without supervision.
- If the power supply cord is damaged or broken, it must be replaced by the manufacturer or a relevant specialist to avoid any injuries.
- Please operate in a clean and safe environment. For example, do not left around your tools. And always be careful to deal with packaging materials, in order to avoid any kinds of possible danger. Potential choking risk exists when children play with plastic bags!
- If necessary, retain the original package for future transportation.

Recycling and Disposal



This product cannot be disposed of as household waste. To prevent damage to the environment, this product should be recycled. Please use the relevant recycling systems available to you or contract the distributor or manufacturer for recycling assistance.

FlexiSpot Limited Warranty

This limited warranty offered by FlexiSpot covers defects in material or workmanship in new FlexiSpot products. This warranty extends to the original purchaser only and is non-transferable. Only consumers purchasing FlexiSpot products from authorized FlexiSpot retailers or resellers may benefit from our limited warranty.

What is Covered?

The FlexiSpot limited warranty covers our products against defects in material or workmanship as follows:

·FlexiSpot Height Adjustable Desk Frames

All height-adjustable desks feature a 5-year warranty for the frame & motor and a 2-year warranty for the controller, switch, electronics and other mechanisms.

·FlexiSpot Sit-Stand Desktop Workstations

All sit-stand desktop workstations feature a 5-year warranty for the frame and MDF desktop and 3-year warranty for the gas spring system and other mechanisms.

·FlexiSpot Desk Bikes

All desk bikes and parts, including the frame, electronics, and other mechanisms, feature a 1-year warranty.

·FlexiSpot Monitor Mounts

All monitor mounts and parts, including arms, gas spring systems and other mechanisms, feature a 5-year warranty.

What are your Remedies?

FlexiSpot will replace at no charge to the consumer the defective parts only or, at FlexiSpot's option, replace any product or part of the product that is defective because of improper workmanship and/or material, under normal installation, use, service and maintenance. If FlexiSpot is unable to provide a replacement and repair is not practical or cannot be completed in a timely fashion, FlexiSpot may elect to refund the purchase price in exchange for the return of the product. In the rare event that your FlexiSpot product is defective, we will provide you with a replacement item shipped at no cost to you within the continental United States. The shipping method for replacement products is FedEx Ground, but expedited shipping is available if you choose to pay the additional expense. In addition, you will need to pay the shipping costs if any products need to be shipped to you at an address outside the continental United States.

REPAIR OR REPLACEMENT (OR, IN LIMITED CIRCUMSTANCES, REFUND OF THE PURCHASE PRICE) AS PROVIDED UNDER THIS WARRANTY IS THE EXCLUSIVE REMEDY OF THE PURCHASER. FLEXISPOT NEITHER ASSUMES NOR AUTHORIZES ANY PERSON TO CREATE FOR ANY OTHER OBLIGATION OR LIABILITY IN CONNECTION WITH THIS PRODUCT.

FlexiSpot Limited Warranty

What is Not Covered?

Our limited warranty does not cover any problem that is caused by:

1. Conditions, malfunctions or damage not resulting from defects in material or workmanship.
 2. Conditions, malfunctions or damage resulting from normal wear and tear, improper installation, improper maintenance, misuse, abuse, negligence, accident or alteration.
 3. Accessories, connected materials and products, or related products not manufactured by FlexiSpot.
 4. Conditions, malfunctions or damage resulting from failure to follow the instructions and guidelines relating to the product's intended use.
- Our limited warranty is void if a product is returned with removed, damaged or tampered labels or any alterations (including removal of any component or external cover).

How to File a Claim?

In order to receive the benefit of our limited warranty, you need to process your claim in compliance with the terms of this limited warranty and follow proper return procedure. To request warranty service, please contact customer service via email at contact@FlexiSpot.com or toll free at +1-855-585-5618. You will need to provide the sales receipt or other evidence of the date and place of purchase for your FlexiSpot product.

Implied Warranties and Limitation of Damages

EXCEPT TO THE EXTENT PROHIBITED BY APPLICABLE LAW, ALL IMPLIED WARRANTIES (INCLUDING WARRANTIES OF MERCHANTABILITY AND FITNESS FOR A PARTICULAR PURPOSE) SHALL BE LIMITED IN DURATION TO THE DURATION OF THIS WARRANTY, AND FLEXISPOT SHALL NOT BE LIABLE FOR ANY INCIDENTAL, INDIRECT, SPECIAL, OR CONSEQUENTIAL DAMAGES, INCLUDING BUT NOT LIMITED TO LOSS OF PROFITS OR REVENUE, RESULTING FROM ANY BREACH OF EXPRESS OR IMPLIED WARRANTY OR CONDITION, OR UNDER ANY OTHER LEGAL THEORY, EVEN IF FLEXISPOT HAS BEEN ADVISED OF THE POSSIBILITY OF SUCH DAMAGES. Some jurisdictions do not allow limitations on the duration of an implied warranty or the exclusion or limitation of special, indirect, incidental or consequential damages, so the above limitations or exclusions may not apply to you.

Governing Law

This Warranty shall be governed by the laws of the State of California, USA, without giving effect to any conflict of laws principles that may provide the application of the law of another jurisdiction.

How State Law Applies

This Warranty gives you specific legal rights, and you may also have other rights which vary from state to state.