

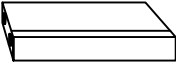

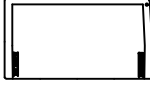

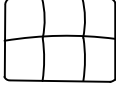





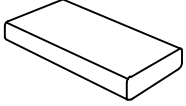
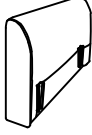
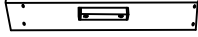

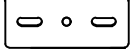





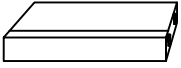
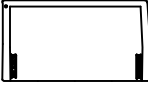

Accessories list(sitting sofa)

Carton 2/2

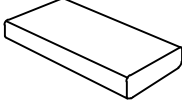
A  Right seat frame(1)	B  Right backrest(1)	C  Back cushion(2)	D  Ottoman base plate (1)	E  Ottoman panel (1)
F  Double seat cushion(1)	G  Right armrest(1)	H  Ottoman side panel (4)	I  Sofa feet (10)	J  Metal plate(2)
K  8*35 Screw(6)	L  18mm Gasket (6)	N  Corner brace connector (4)	M  6*16 Screw(16)	O  18mm Gasket(16)
P  M5*100*55 Wrench(1)	Q  Metal plate(1)	R  M4*65*23 Wrench(1)	X  Sofa feet(2)	

Carton 1/2

S  Left seat frame(1)	T  Left backrest(1)	C  Back cushion(2)	F  Double seat cushion(1)	U  Left armrest(1)
V  Ottoman seat cushion(1)	W  Armrest soft bag(2)			

STEP1:

Install sofa feet to the base plate of ottoman with hardware
Note: Hardware face the smooth surface of ottoman base.

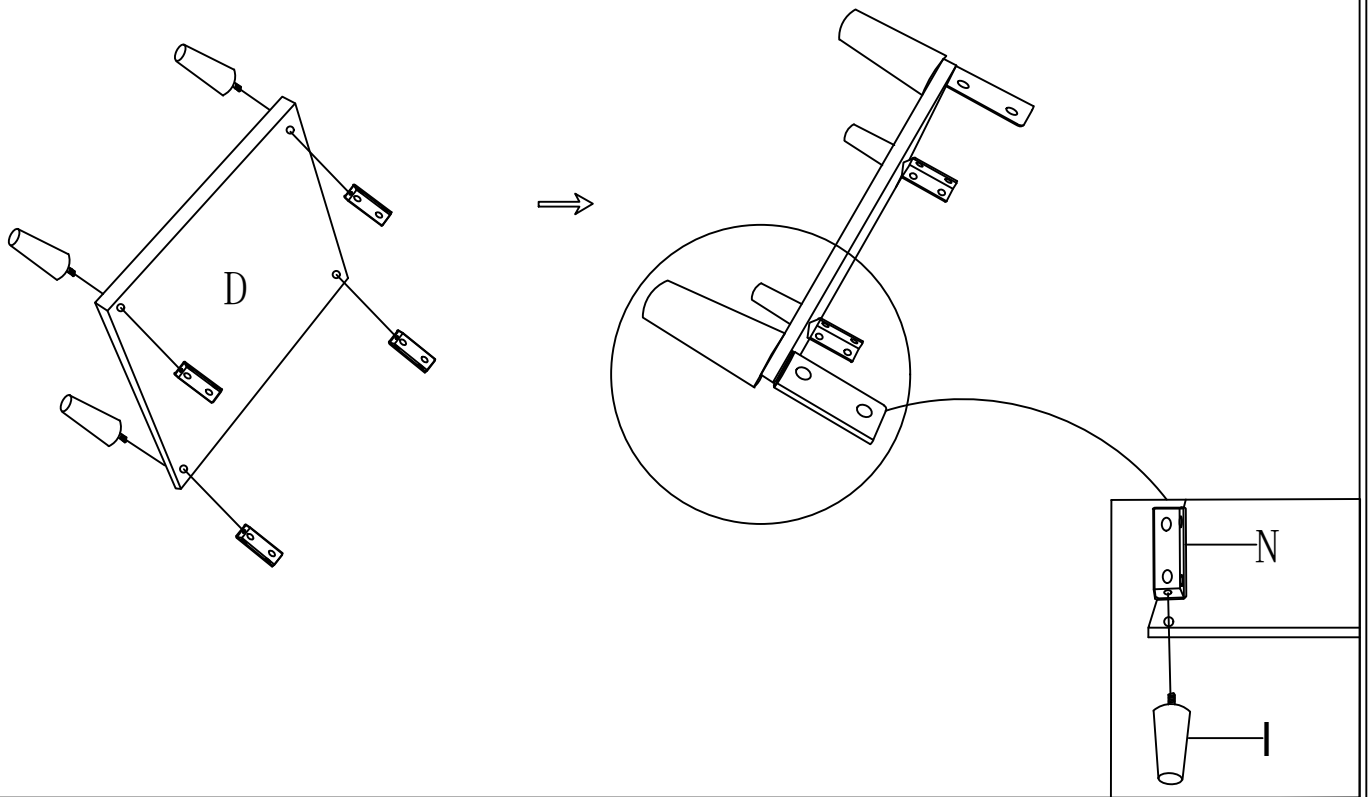

STEP3:

Connect the side panels of ottoman to the base plates with conner brace connector. Note: please distinguish between top and bottom of the side panels

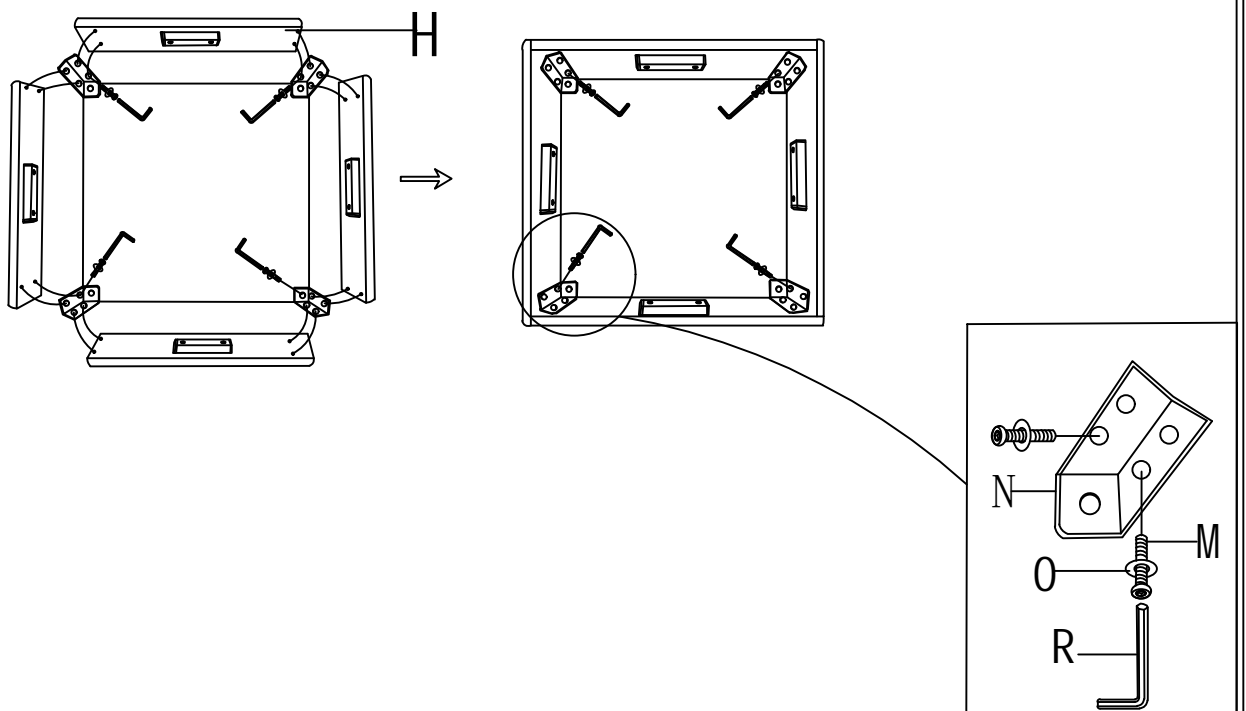

STEP3: Place the ottoman panel on the ottoman frame

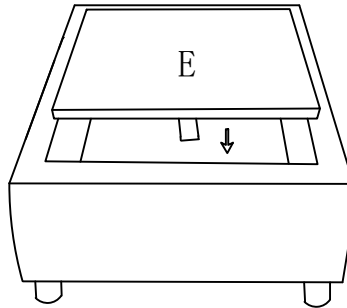

STEP4: Install the right armrest to the right seat frame.

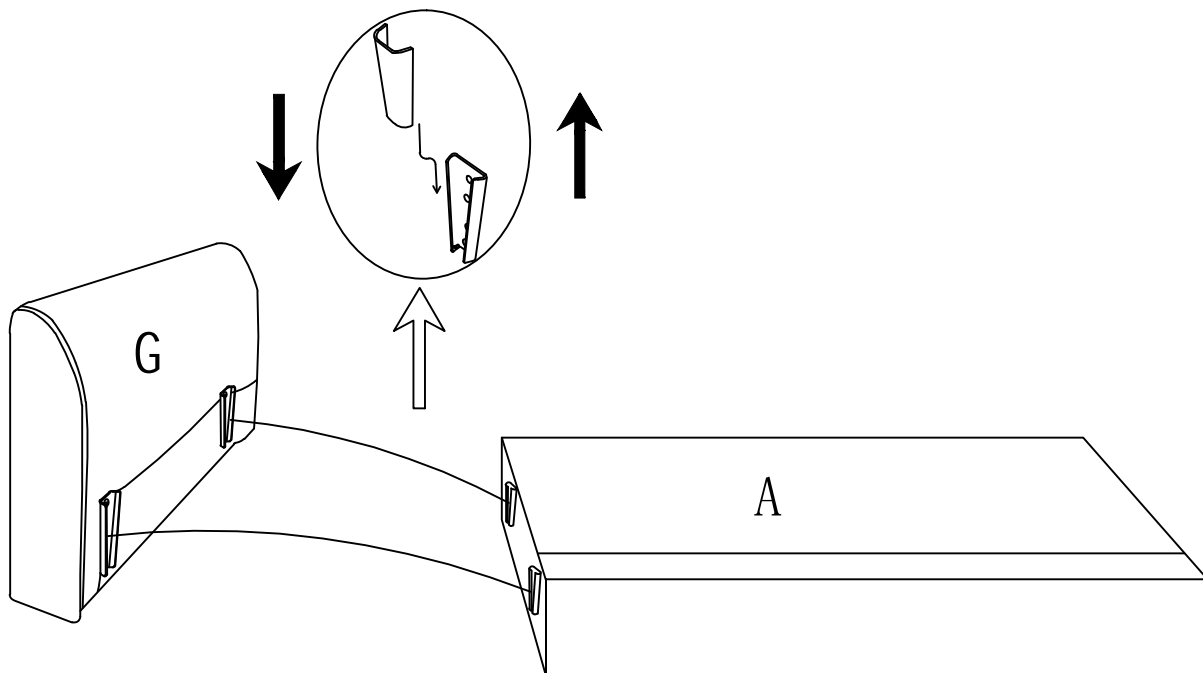

STEP5: Install the left armrest to the left seat frame.

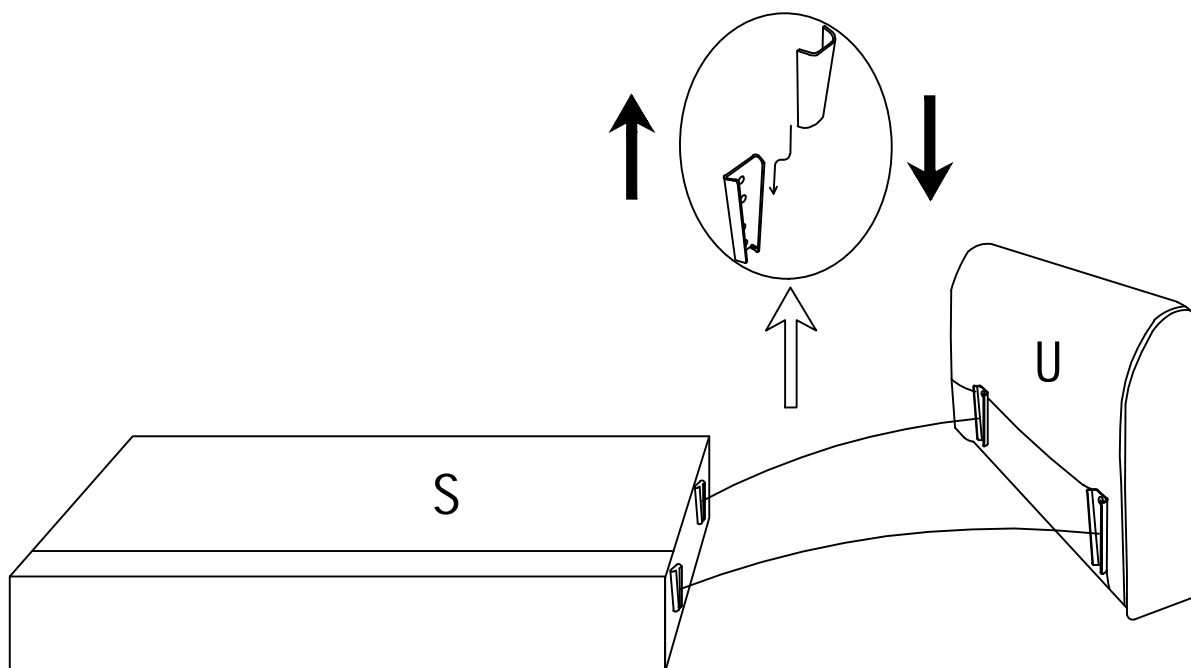

STEP6: Connect the fixed hardware in the middle of the sofa and install the sofa feet.

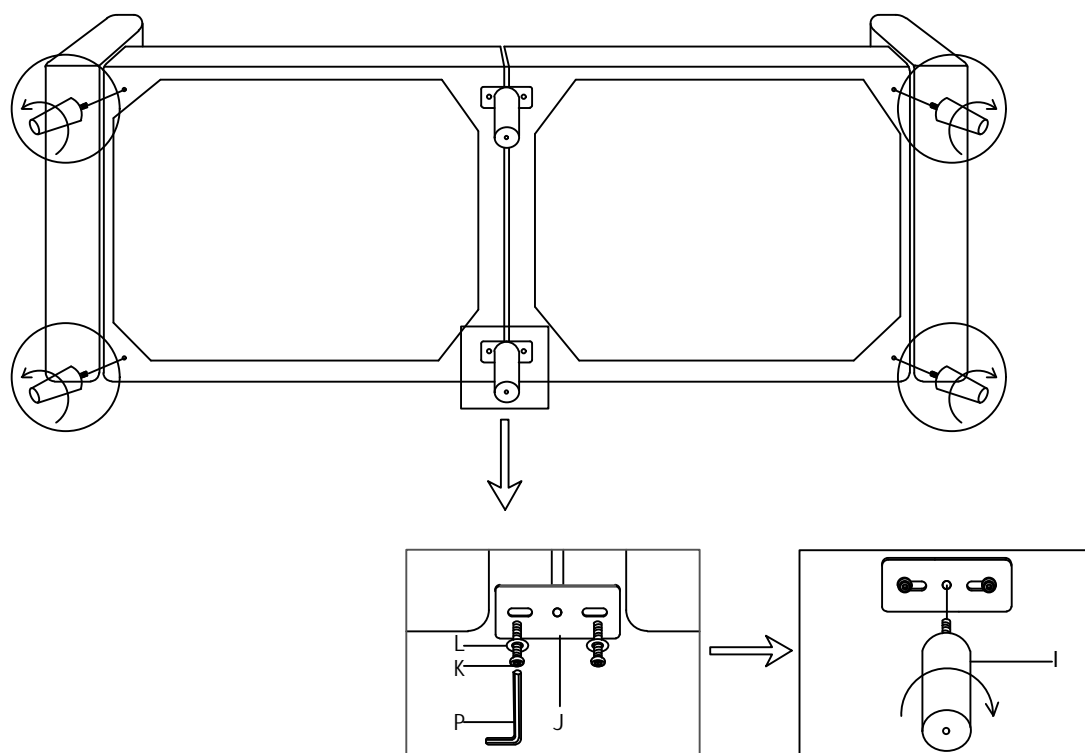

STEP7: Insert the backrest into the sofa base

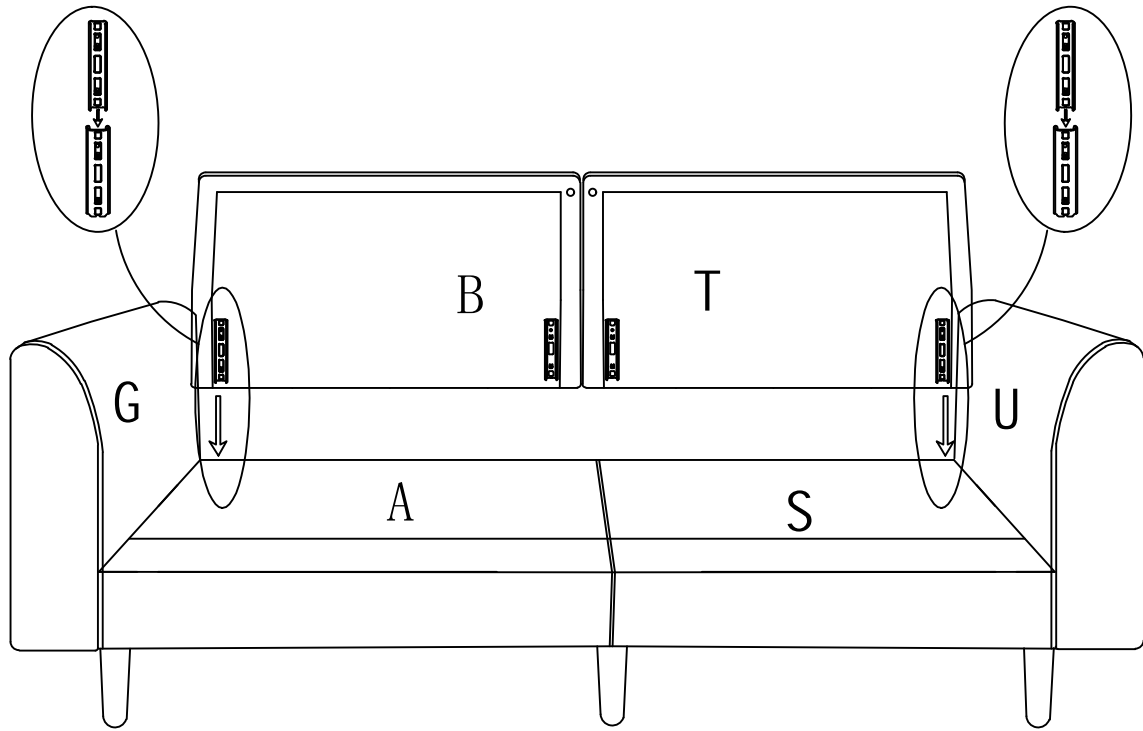

STEP8: Lock the backrest with the metal plate

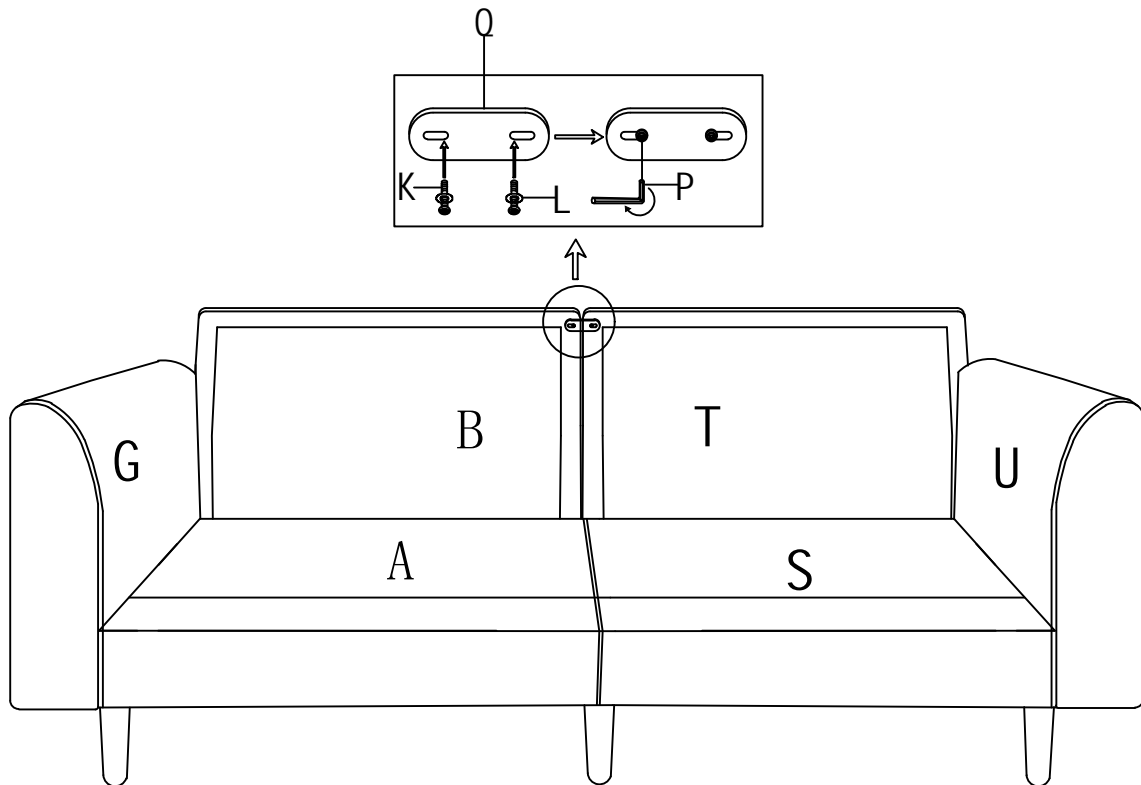

STEP9: Cutting open the compression bag

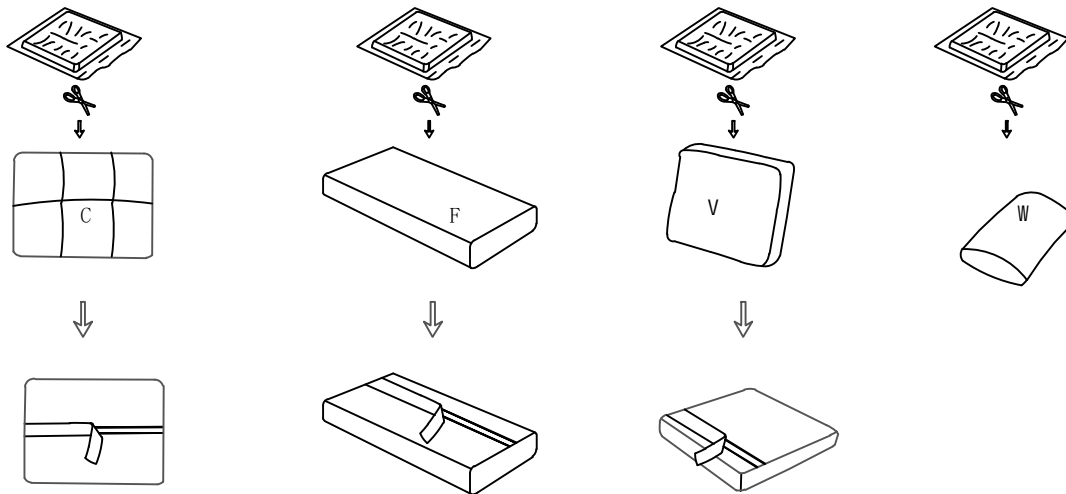

STEP10: Put the seat cushion and then the back cushions on the sofa

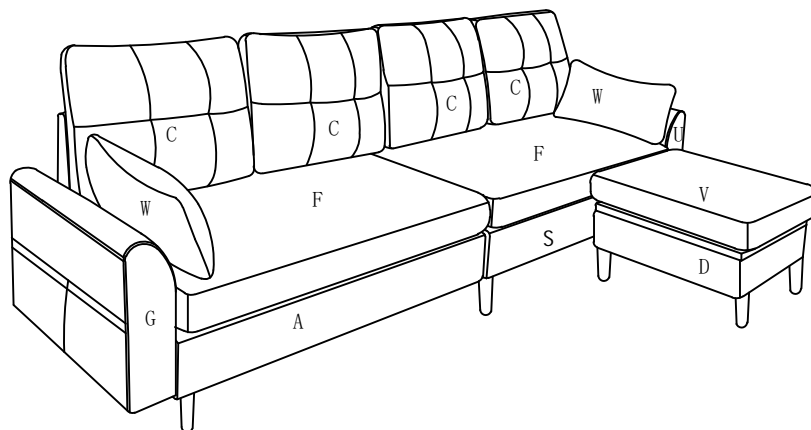
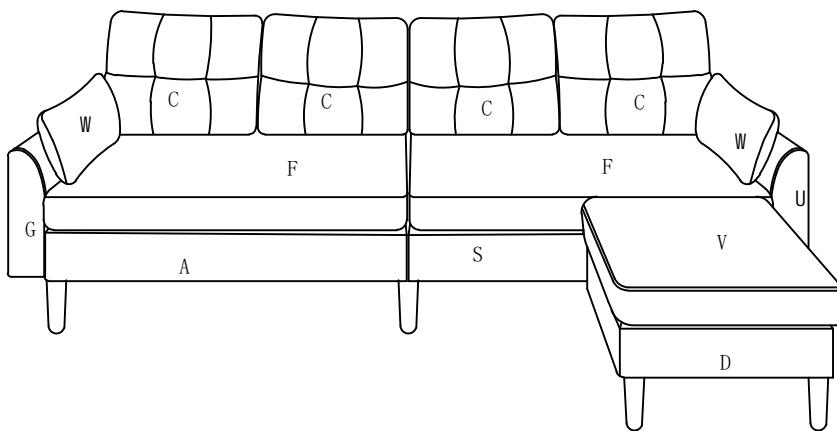

1. Part T, U, C, F, V, W placed in the box 1/2 (S)

2. Part B, C, D, E, F, G, H, I, J, K, L, N, M, O, P, Q, R are placed in the box 2/2 (A)

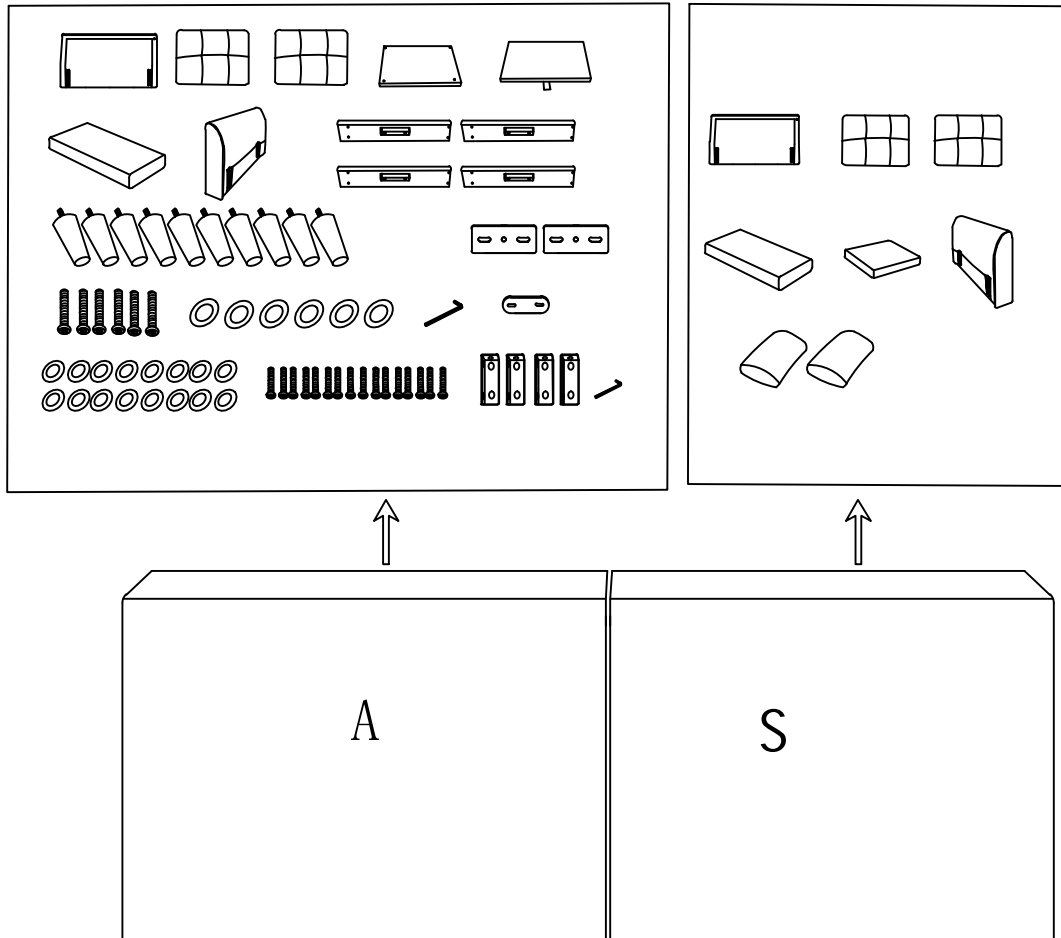

This set of sofa only requires 10 legs. Please pay attention to check the installation position. The extra 2 legs are spare ones.