

Assembly Instructions

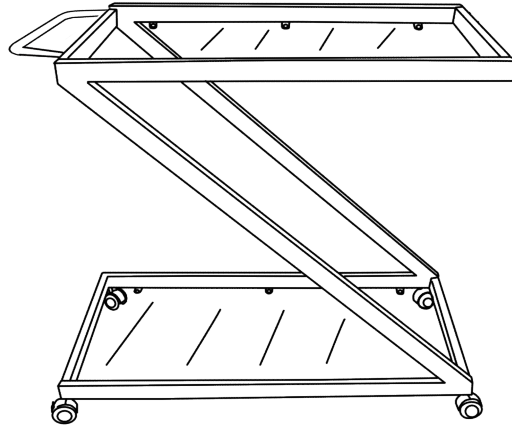



Caution: You must read this before you proceed

Bar Cart



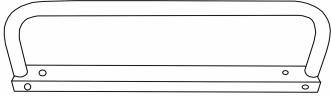

Parts List

Label	Picture	Description	QTY
A		Right Frame	1
B		Left Frame	1
C		Support bar	3

D		Handle	1
E		Top Glass	1
F		Bottom Glass	1
G		Wheel	2
H		Wheel with Brake	2

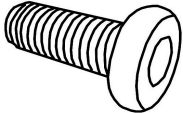
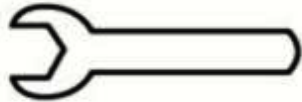
Hardware

Label	Picture	Description	QTY
①		Allen Wrench(M6)	1
②		Bolt(M6*15MM)	12
③		Spanner(M8)	1
④		Glass Suction Cup(D2CM)	14

Assembly Preparation

Before Beginning Assembly :

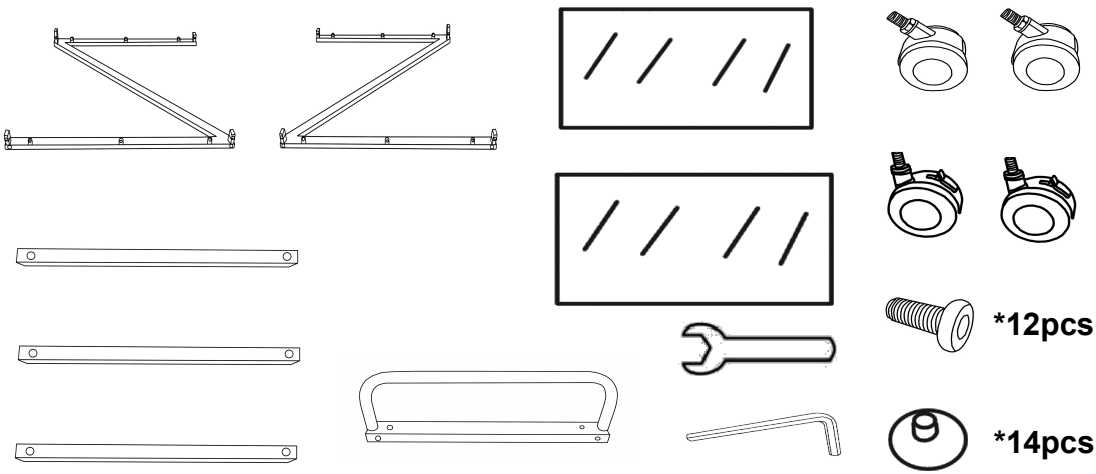

• Read instructions, cover to cover-



• Have 2 adults on hand for assembly-



• Do not assemble on flooring or carpet-



• Assemble on a clean non-marring surface (packing foam)-



• Save all packaging until finished-

Assembly Steps

Overview

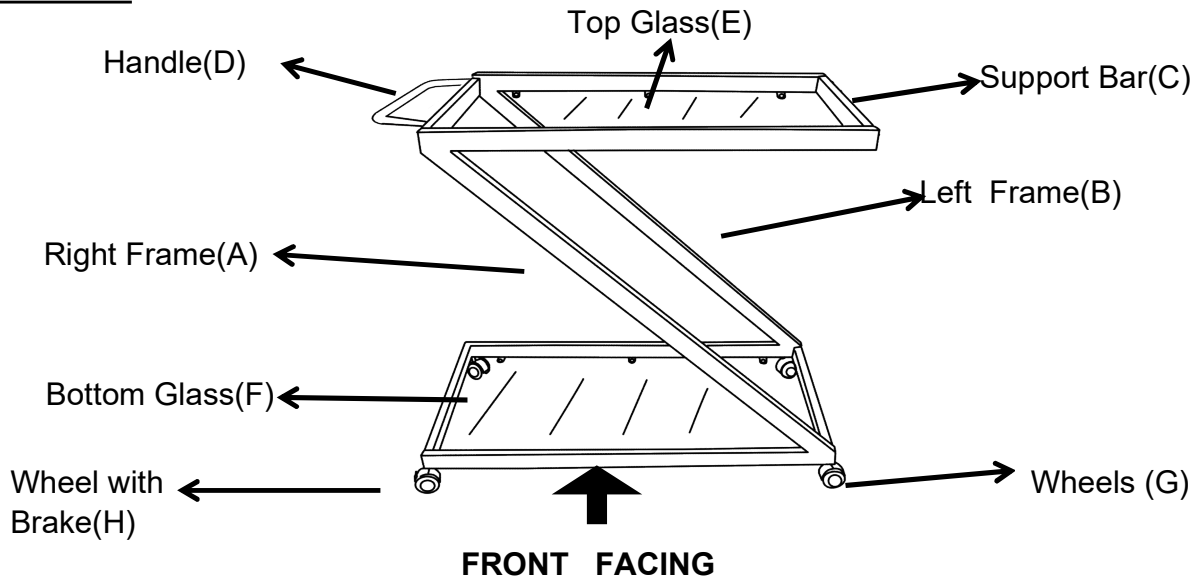

This Bar Cart has multiple parts and may require up to some 30 minutes to assemble. To give you an overview of the Bar Cart parts, the above picture is to help you put the various parts into perspective. Please read through the instructions herebelow to familiarise yourself with the parts and steps before assembly.

Step 1

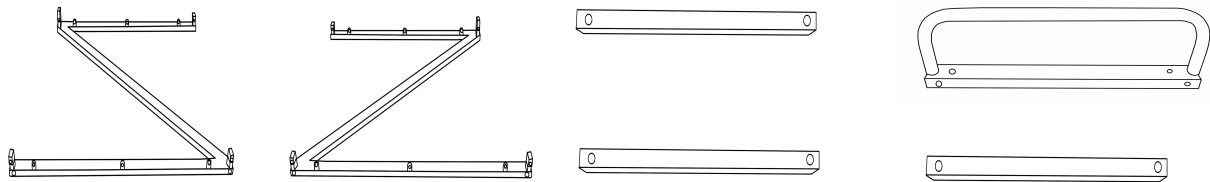

Unpack all parts and place on a clean, non-marring surface.

Step 2

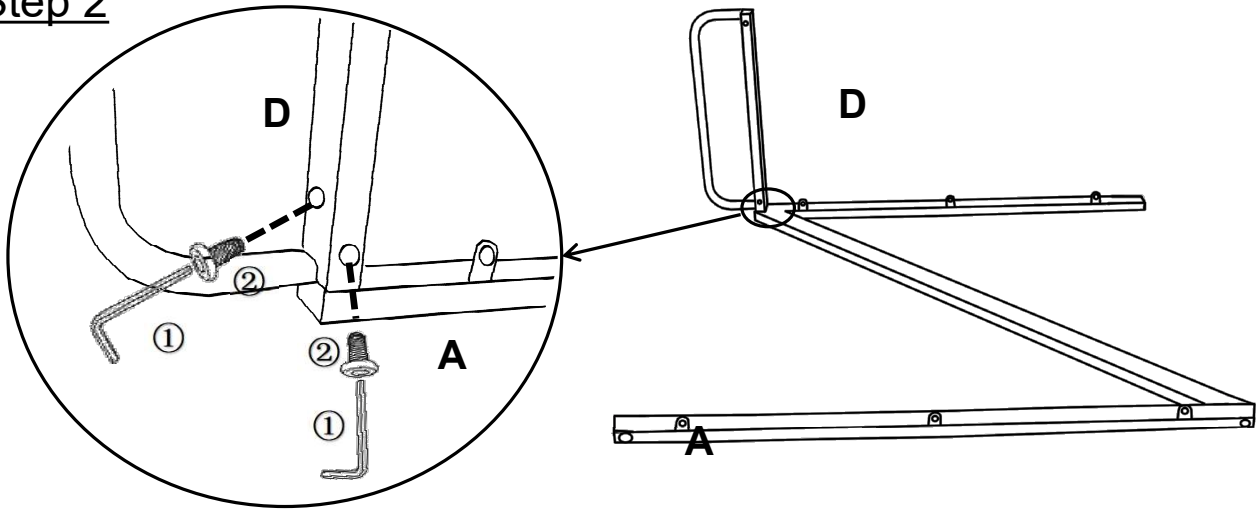

Attach one of the Handle (D) to the Right Frame(A) using Bolt(2) with the Allen Wrench(1).

Loosely tighten the Bolt.

Step 3

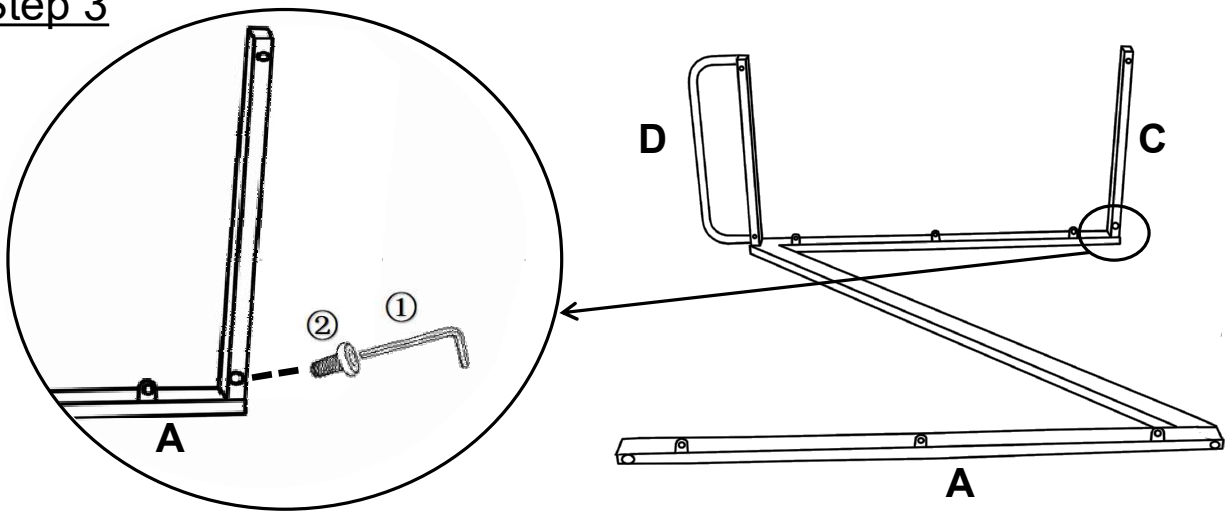

Attach one of the Support bar (C) to the Right Frame(A) using Bolt(2) with the Allen Wrench(1).

Loosely tighten the Bolt.

Step 4

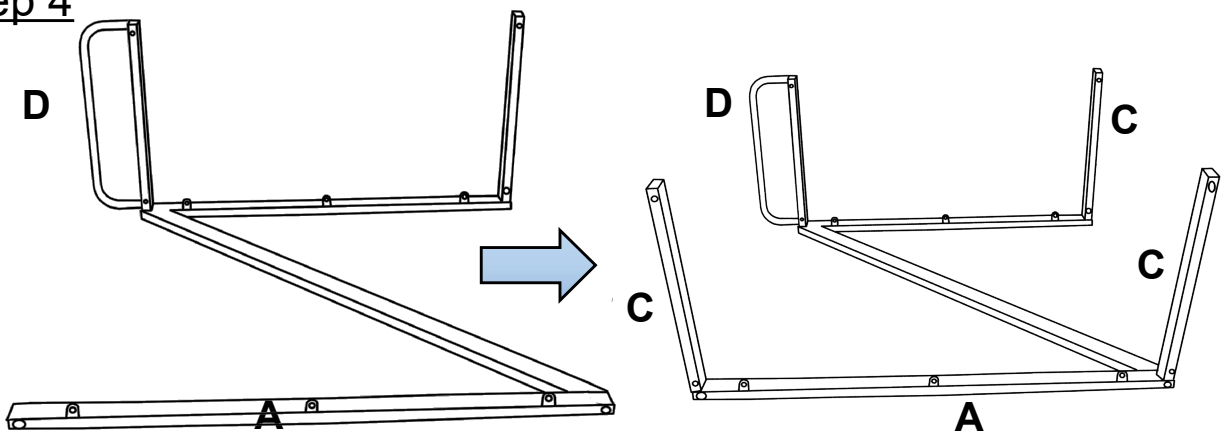

Repeat Step 2 to assemble the remaining Support Bars (C) using Bolts(2) with the Allen Wrench(1).

Loosely tighten the Bolts.

Step 5

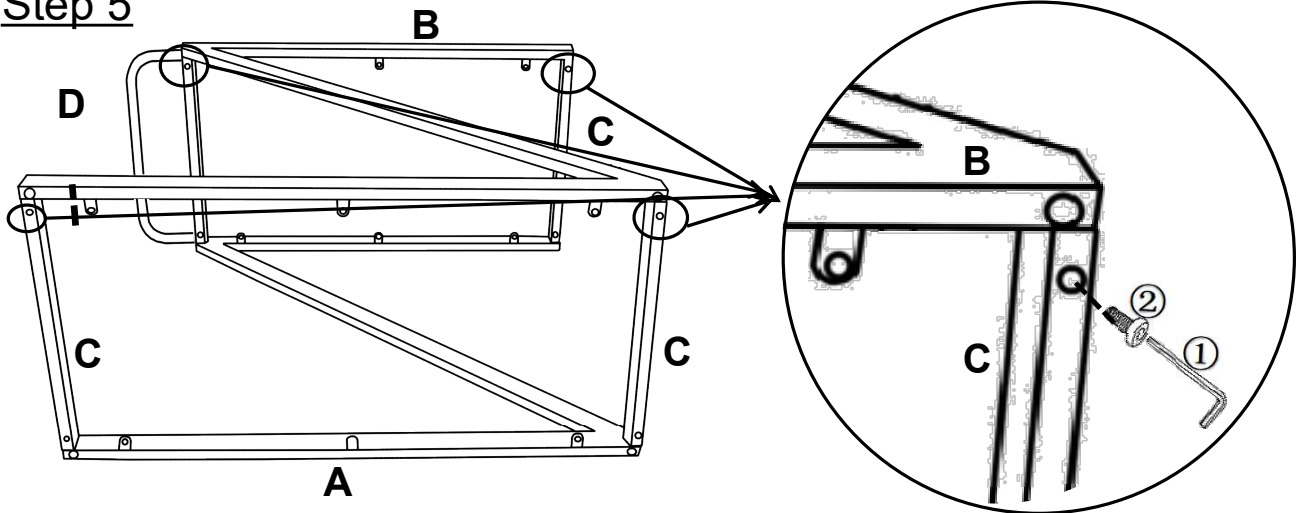

Repeat Step 1-4 to Connect the Left Frame(B) to the Pre-assembled Frame(A, C, D), using Bolts(②), with the Allen Wrench(①) as shown in the above picture.
**Note: Use your hand to straighten the bars and the handle of the Bar cart if you find that the screw hole position is uneven.
Tighten the Bolts.**

Step 6

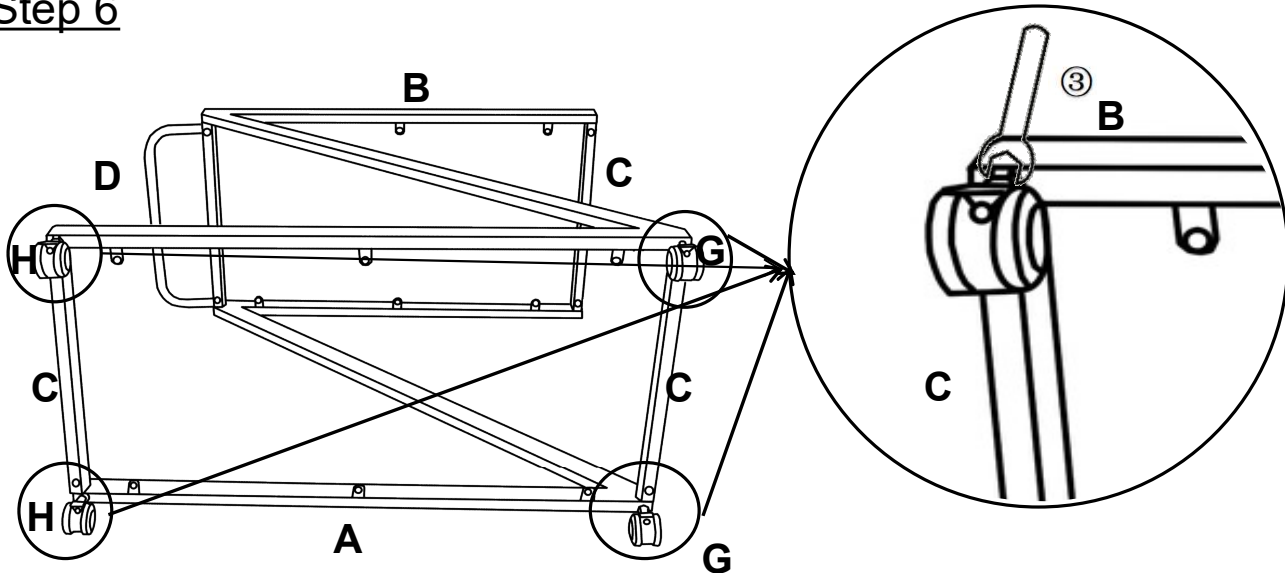

Attach the Wheels(G) and the Wheels with Brakes(H) to the Right Frame(A) and the Left frame(B) using the Spanner(③).
Fully tighten all Bolts at all joints in a sequential manner.

Step 7

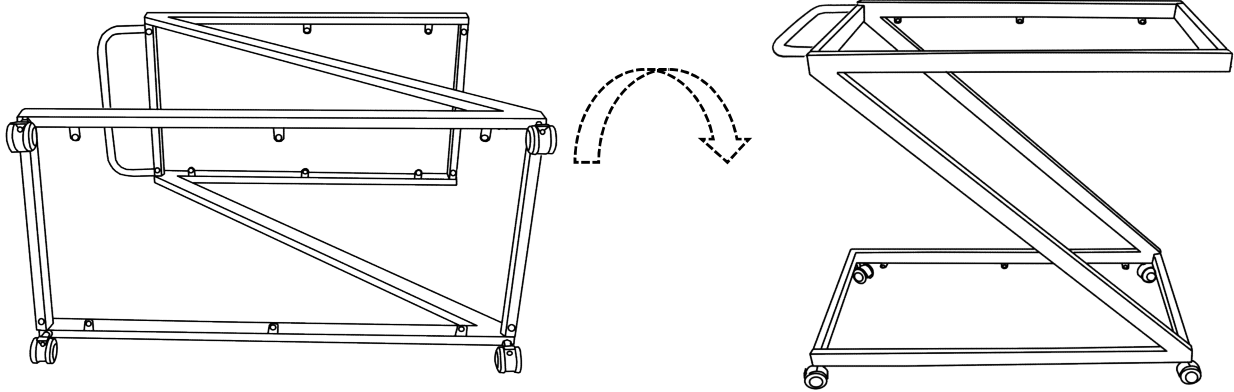

Turn the Bar Cart right side up.

Step 8

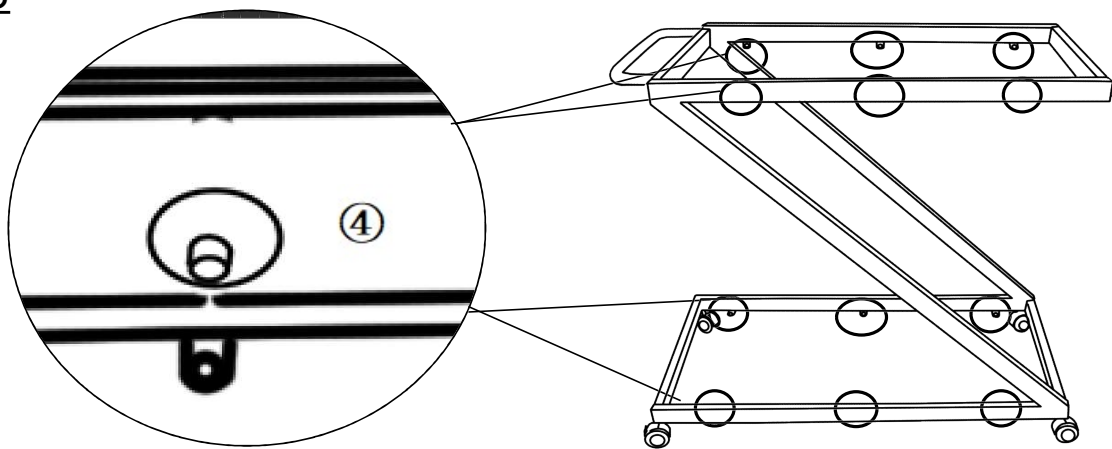

Attach the Glass Suction Cups (④) to the Pre-assembled Frame as shown.

Note: You can press the Glass Suction Cups (●) with the Allen Wrench (●) if they do not attach easily.

Step 9

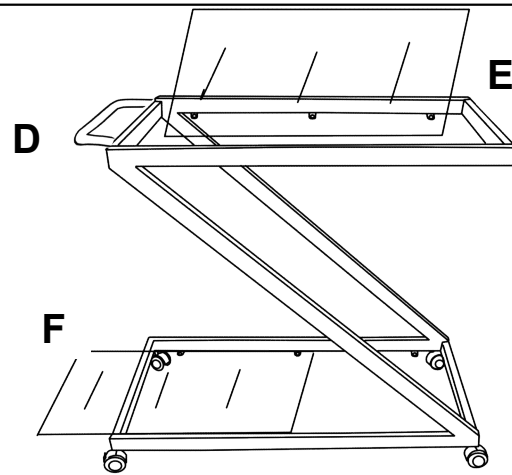

Attach the Glass (E,F) to the Cart Frame.

Note: Gently press down on the glass after you put it into the frame.

Please gently push down on each corner to adjust the gap between the glass and the frame.

Then, in a sequential manner, ensure all bolts at all joints are fully tightened.

Step 10

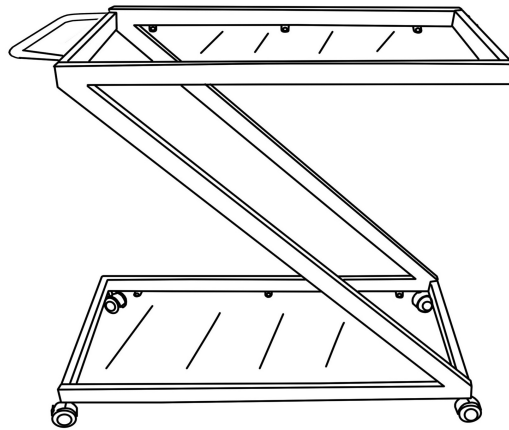

Your Bar Cart is ready for use.

This Bar Cart can only be used on a flat ,level surface.

Care & Maintenance



- Furniture may scratch floors. We recommend using furniture pads to protect your floors.



- Do not put hot items directly on furniture surface.

—



- Do not clean furniture with harsh cleansers or polish.



- Do not place furniture under direct sunlight.



- Do not place furniture near heating or cooling vents.



- Do not write on furniture without a padded barrier to protect the surface.



- Do not place furniture outside . For indoor use only.



- Not for commercial use. For residential use only.



- Stains may be removed with mild soap solution and damp cloth.



- Children should not climb or jump on the furniture.



- Dust and pick-up spills using a clean, non-colored, lint-free cloth.