

Step 1. All the packages are intact, then let's start unpacking. Cut the PP tape with scissors and open the box directly.

1 2  
3 4

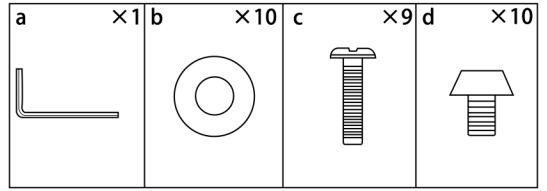

Step 2. Prepare all parts well. (NO.d is the height adjustment screw - optional: they can be installed at the bottom of the base if the ground is uneven.)

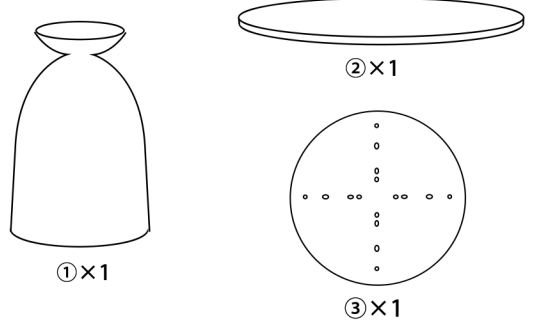
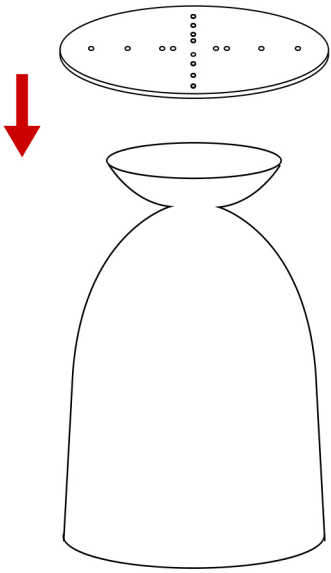

Step 3: First place the connection plate on the base.

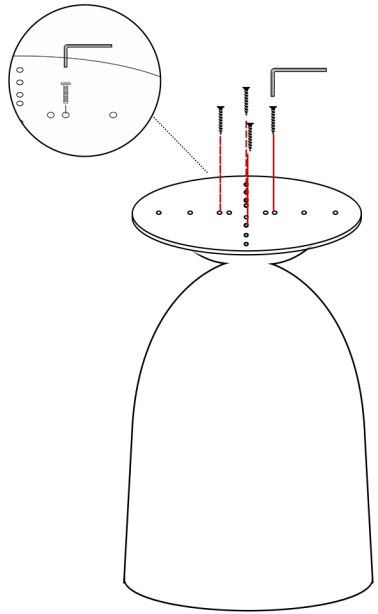

Step 4. Align the holes of the connecting plate with the holes of the base, then tighten the 4 screws.

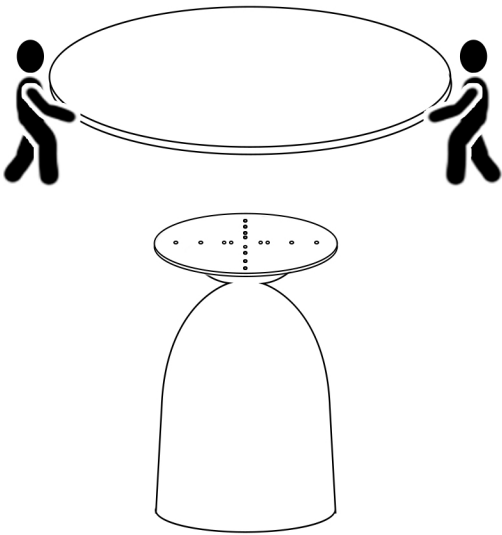

Step 5. Two people lift the tabletop and place it on the installed base. Match the hole positions of the desktop and the connecting plate.

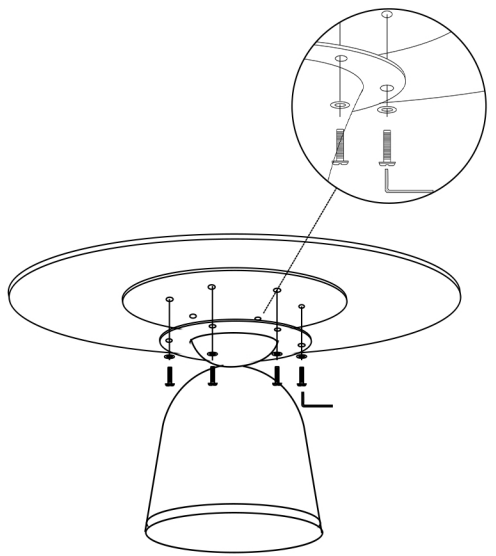

Step 6. Squat down and tighten the screws corresponding to the holes on the desktop. (If the bottom of table is too dark, it is recommended to use a flashlight to illuminate the hole to help complete it quickly)

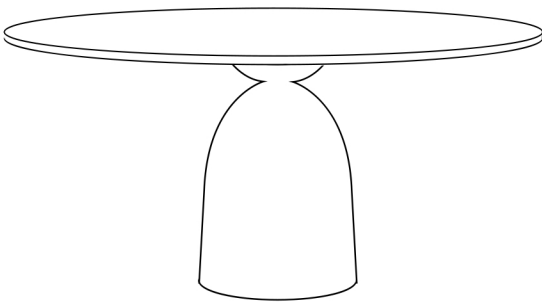

Step 7: Assembly is completed. Wish you enjoy the warm dining moments and share happy moments with family and friends!

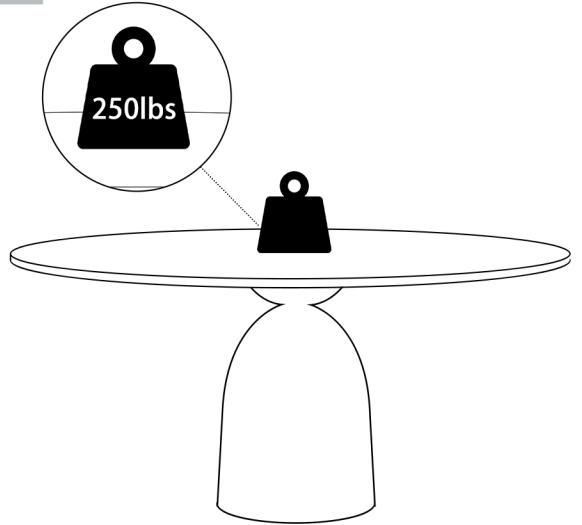

Step 8: Estimated load-bearing weight in daily use.

**Tip:** It is recommended not to lock each screw at first. When you reach the last screw, lock the previous screws that were not fully tightened.