

WHITE : BLANC : *BLANCO*

CHOCOLATE : CHOCOLAT : *CHOCOLATE*

**ASSEMBLY
INSTRUCTIONS**

**INSTRUCTIONS
D'ASSEMBLAGE**

**INSTRUCCIONES DE
ENSAMBLAJE**



Thank you for choosing a product. Your total satisfaction is our #1 priority.

Customer Service and warranty information

Should you have a problem or need more information concerning the warranty, **do not call to the place of purchase.**
Please call our customer service department for immediate assistance.

Please have your assembly instruction manual on hand when you call. Our products are warranted to the original purchaser against defects in material or workmanship in the furniture. Defects as mentioned in this warranty refer to any imperfections which may impair the use of the product. Our warranty is expressly limited to the replacement of furniture parts and components for ten years following the date of purchase. We will replace any part that is defective. This warranty applies under conditions of normal use. Our furniture products are not intended for outdoor use. The warranty does not cover defects caused by improper assembly or disassembly, defects occurring after purchase due to product modifications, intentional damage, accident, misuse, exposure to the elements and labor or assembly costs. We reserve the right to request proof of purchase to document a warranty claim. In no event shall we be liable for incidental or consequent damages resulting from the misuse of the product. This warranty is not transferable and is valid only in Canada and the United States excluding Alaska, Hawaii and Puerto Rico.









**MERCI D'AVOIR CHOISI LES PRODUITS.
VOUS SATISFAIRE EST NOTRE PRIORITÉ.**

***Gracias por elegir un producto.
Su entera satisfacción es nuestra prioridad N°1.***



PARTS / PIÈCES / PIEZAS

CODE / CÓDIGO	QTY / QTÉ / CANT.	CODE / CÓDIGO	QTY / QTÉ / CANT.	CODE / CÓDIGO	QTY / QTÉ / CANT.	CODE / CÓDIGO	QTY / QTÉ / CANT.
10	6		3	bottom / fond / fondo 32 1/2" x 15 3/8" (828 mm x 391 mm)	3	drawer front / devant de tiroir fachada del cajón	3
13	6						

HARDWARES / QUINCAILLERIES / QUINCALLAS

CODE / CÓDIGO	QTY / QTÉ / CANT.	CODE / CÓDIGO	QTY / QTÉ / CANT.	CODE / CÓDIGO	QTY / QTÉ / CANT.	CODE / CÓDIGO	QTY / QTÉ / CANT.
			3		1" (25 mm) 6		1" (25 mm) 36
runners 400 mm (15 3/4") coulisseaux 400 mm correderas 400 mm			6		3/4" (20 mm) 12		
	12		12		1/2" (13 mm) 18		

REAL SIZE / GRANDEUR RÉELLE / TAMAÑO REAL

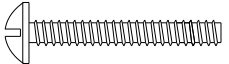
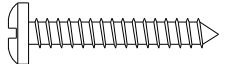
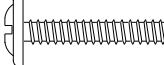
CODE / CÓDIGO	QTY / QTÉ / CANT.	CODE / CÓDIGO	QTY / QTÉ / CANT.
	3/8" (10 mm) 12		1/2" (13 mm) 18
	1" (25 mm) 6		1" (25 mm) 36
	3/4" (20 mm) 12		



two people are required to assemble and move this model.
deux personnes sont requises pour assembler et déplacer ce modèle.
se necesitan dos personas para ensamblar y desplazar este mueble.

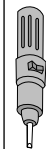

the use of electric tools must be made with vigilance.
l'utilisation d'outils électriques doit être faite avec vigilance.
las herramientas eléctricas deben utilizarse con sumo cuidado.

tools required
outils requis
herramientas necesarias

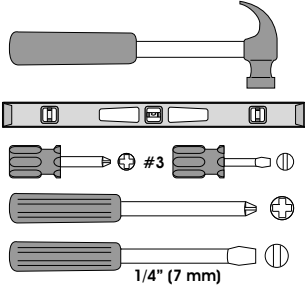
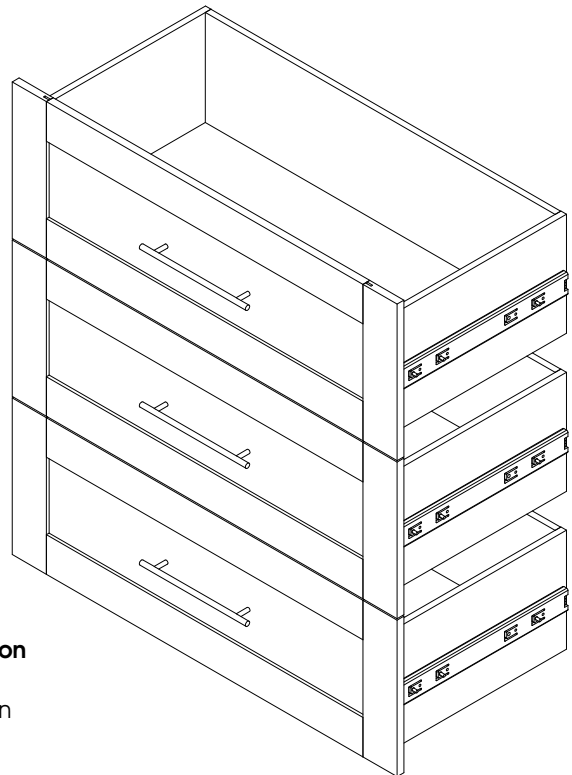
IMPORTANT NOTICE / NOTE IMPORTANTE / NOTA IMPORTANTE

Group together all the hardware required for each step as the construction of your piece of furniture is progressing.

Regroupez toutes les quincailleries requises pour chaque étape de façon à vous assurer de tout installer au bon moment.

Reúna todas las quincallas necesarias para cada una de las etapas de montaje, para asegurar una correcta instalación en el momento adecuado.

IMPORTANT NOTICE / NOTE IMPORTANTE / NOTA IMPORTANTE

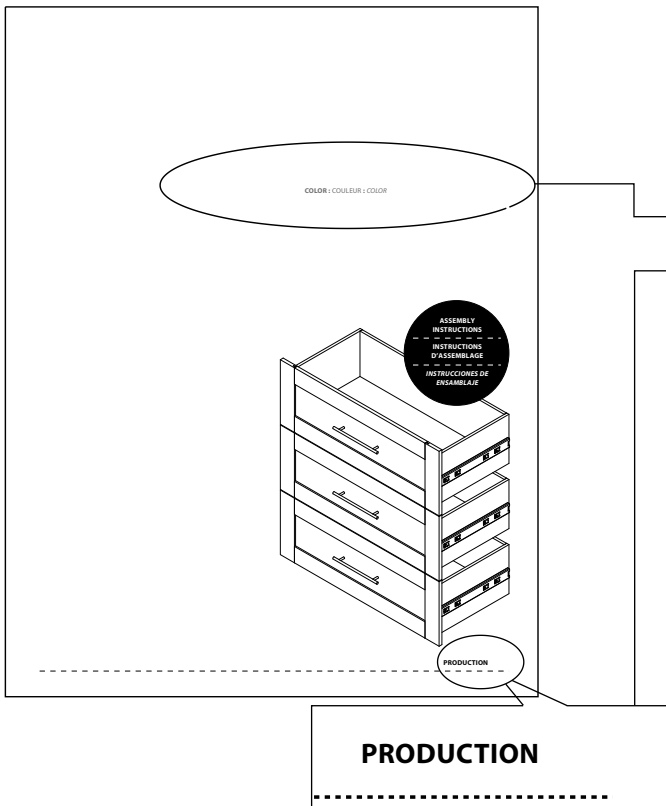

To better serve you!
Pour mieux vous servir!

→ **Model / Modèle:** _____

→ **Production Number**
Numéro de production: _____

Customer Service
Service à la clientèle

For future reference and to better serve you, please complete and apply the self-adhesive sticker in an accessible space such as inside a drawer when you will have completed the assembly.

Pour mieux vous servir en cas de besoin, veuillez compléter et apposer l'autocollant dans un endroit facilement accessible tel que l'intérieur d'un tiroir lorsque vous aurez complété l'assemblage.

Para uno mejor servicio en caso de necesidad, complete y poner la etiqueta en uno lugar de fácil acceso como por ejemplo al interior de un cajón cuando usted habrá completado el ensamblaje.

Main hardware system. Installation steps / Système de quincaillerie principal. Étapes d'installation.
Sistema principal de quincalla. Etapas de instalación.

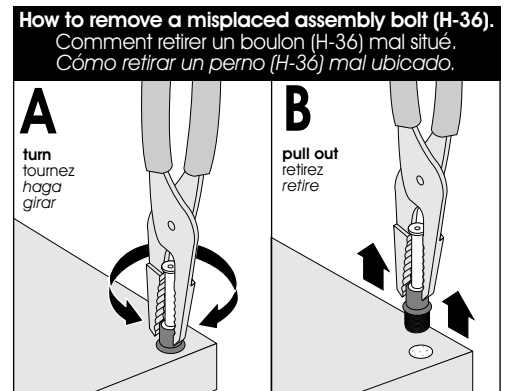
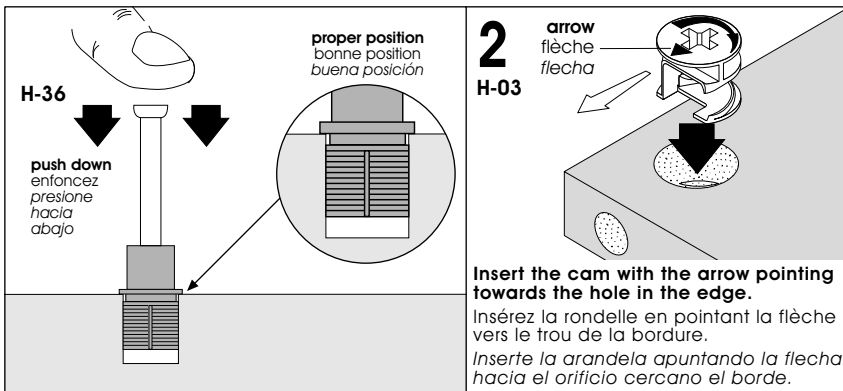

Main hardware system. Assembly steps / Système de quincaillerie principal. Étapes d'assemblage.
Sistema principal de quincalla. Etapas de ensamblaje.

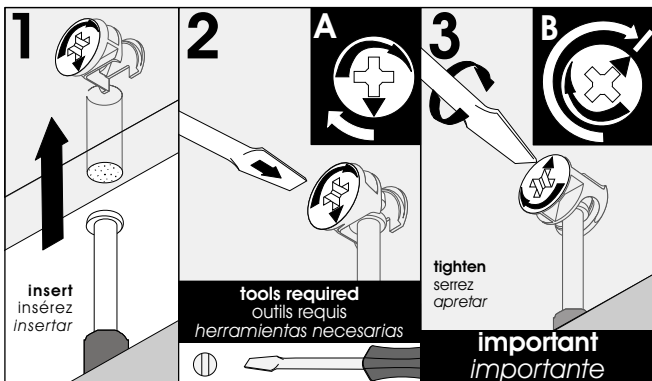

Make sure to properly tighten each cam to ensure furniture solidity. Otherwise, parts could be damaged or the user could be injured.

Assurez-vous de bien resserrer chaque rondelle pour assurer la solidité du meuble. Dans le cas contraire, des pièces pourraient être endommagées ou l'utilisateur pourrait se blesser.

Asegúrese de apretar bien cada arandela para garantizar la solidez del mueble. De lo contrario, podría provocarse daño a las piezas o las personas.

1

Hardware installation / Installation des quincailleries / Instalación de las quincallas

Use these holes from 26160 (not included)
Utilisez ces trous du 26160 (non-inclus)
Utilice estos orificios de 26160 (no se incluye)

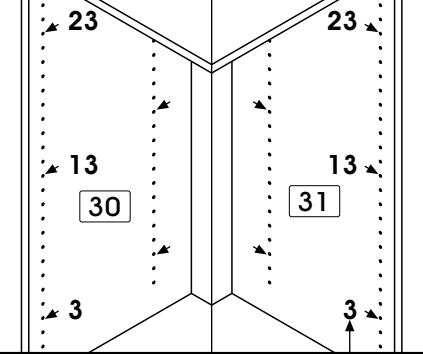

Holes position are from bottom up
Position des trous de bas en haut
Posición de los hoyos de bajo arriba

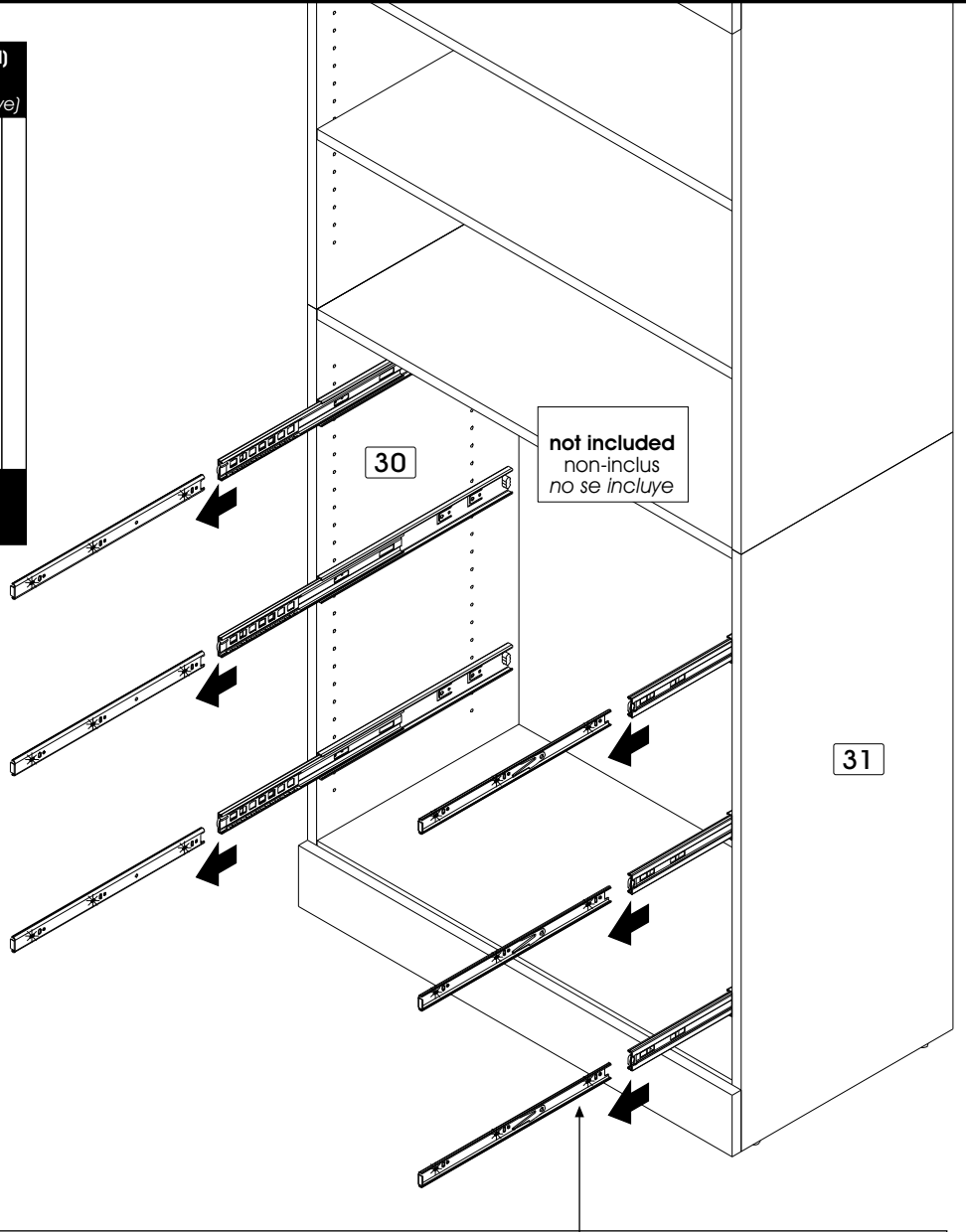

CO-249

Use these holes / Utilisez ces trous / Utilice estos orificios

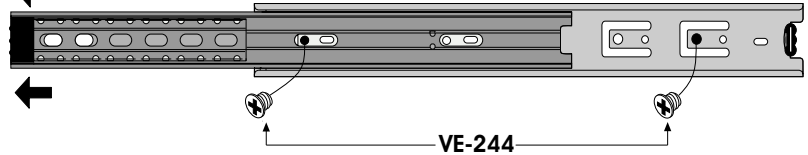

VE-244

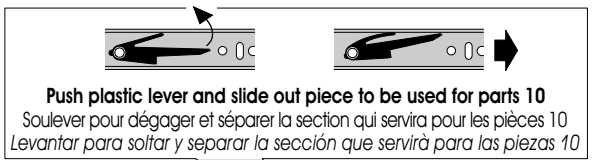
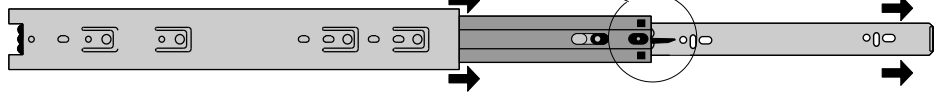

Soulever pour dégager et séparer la section qui servira pour les pièces 10
Levantarse para saltar y separar la sección que servirá para las piezas 10

1

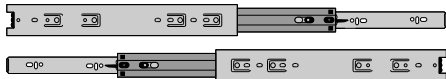

Code / Código

CO-249

VE-244

Qty / Qté / Cant.

x 3

x 12

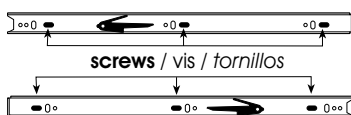
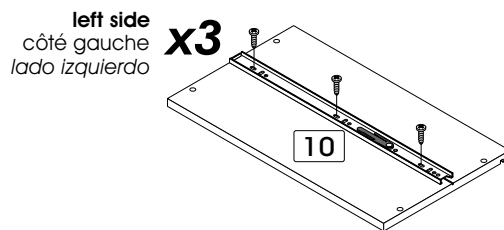
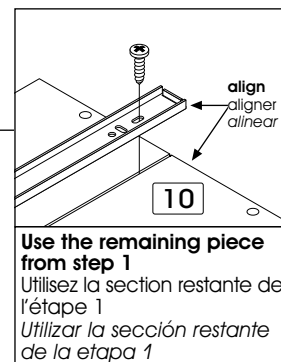
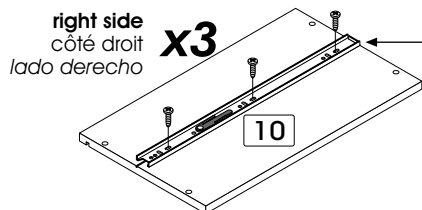
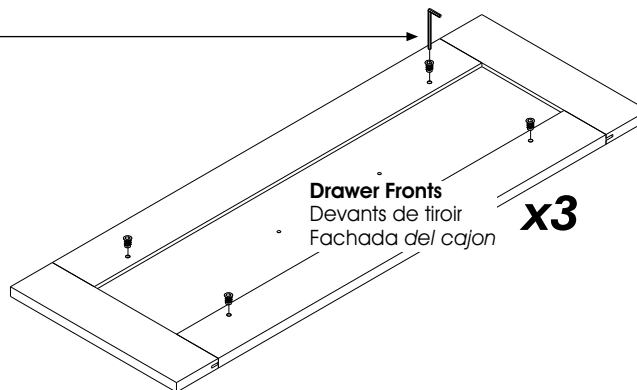
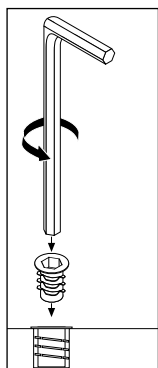

Code / Código

CO-249

EC-744

CL-745

VR-207

Qty / Qté / Cant.

x 3

x 12

x 1

x 18

3x**Assemble upside down**

Assemblez en position renversée

Realice el ensamblaje en posición invertida

Assembling sequence

Séquence d'assemblage

Secuencia de ensamblaje

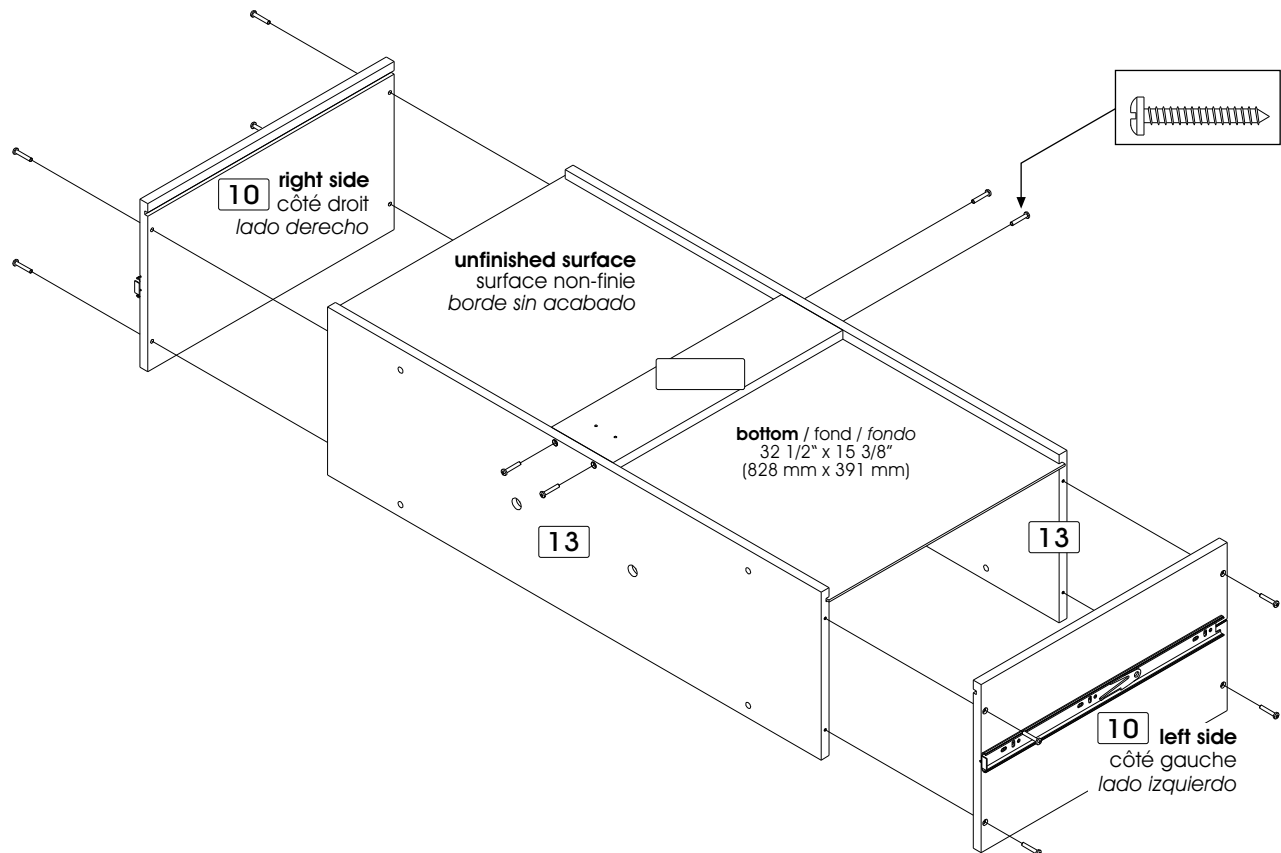
Parts / Pièces / Piezas:**13** **10** **10** + **bottom / fond / fondo** + **13** **CL81B**

Code / Código

VR-212

Qty / Qté / Cant.

x 36

Assemble on the back edge

Assemblez sur la bordure arrière

Realice el ensamblaje sobre el borde trasero

Assembling sequence

Séquence d'assemblage

Secuencia de ensamblaje

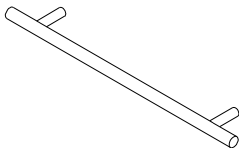
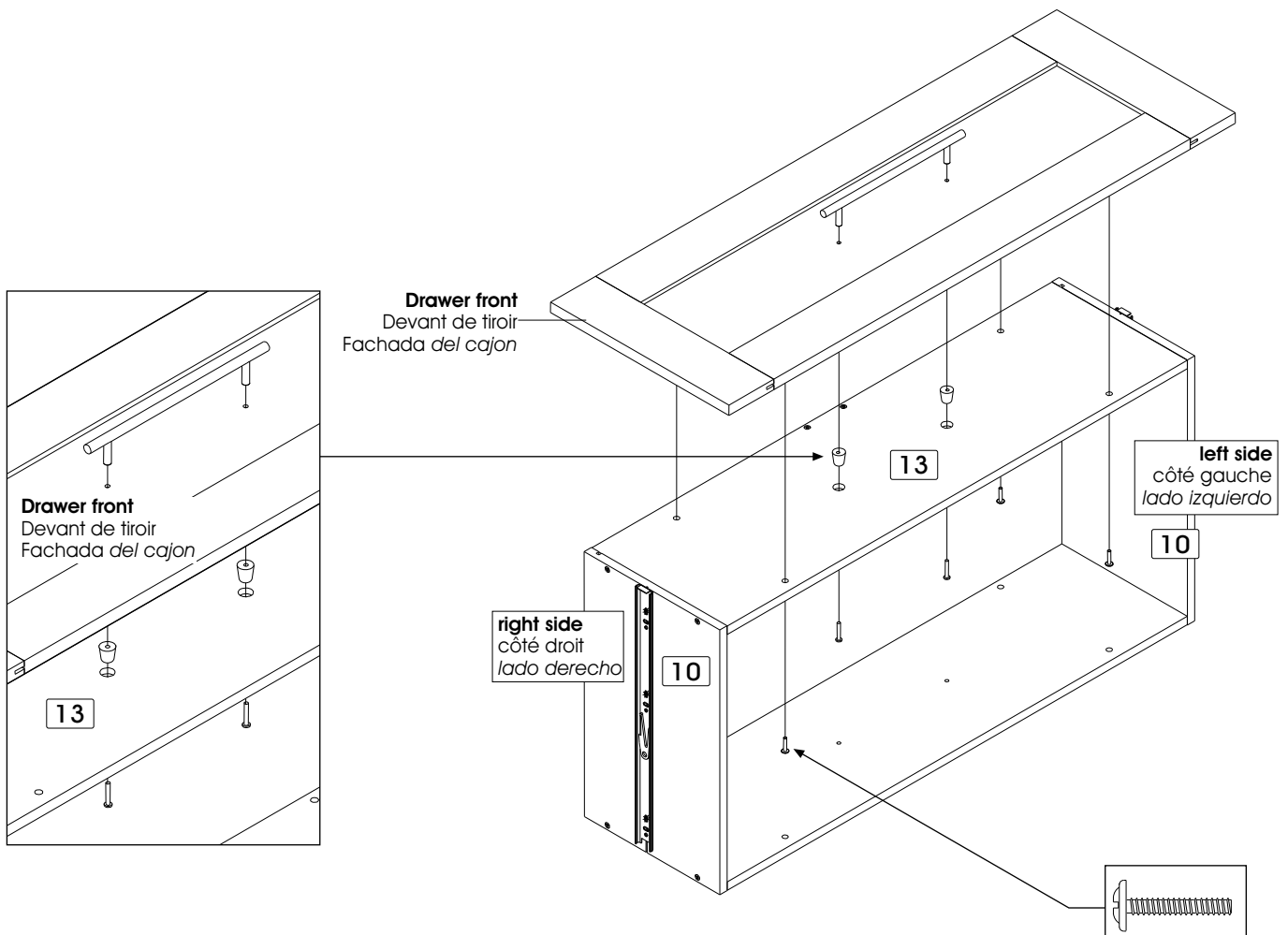
3x**Parts / Pièces / Piezas:****13** + **Drawer Fronts / Devants de tiroir / Fachada del cajon**

Code / Código PO-959

Qty / Qté / Cant. x 3



RO-95

x 6



VM-601

x 12



VF-964

x 6



Important/Importante

Each drawer can support an approximative weight of 60 pounds (27.3 kg).

Chaque tiroir peut supporter un poids maximal approximatif de 60 livres (27.3 kg).

Cada cajón puede soportar aproximativamente un peso de 60 libras (27.3 kg).

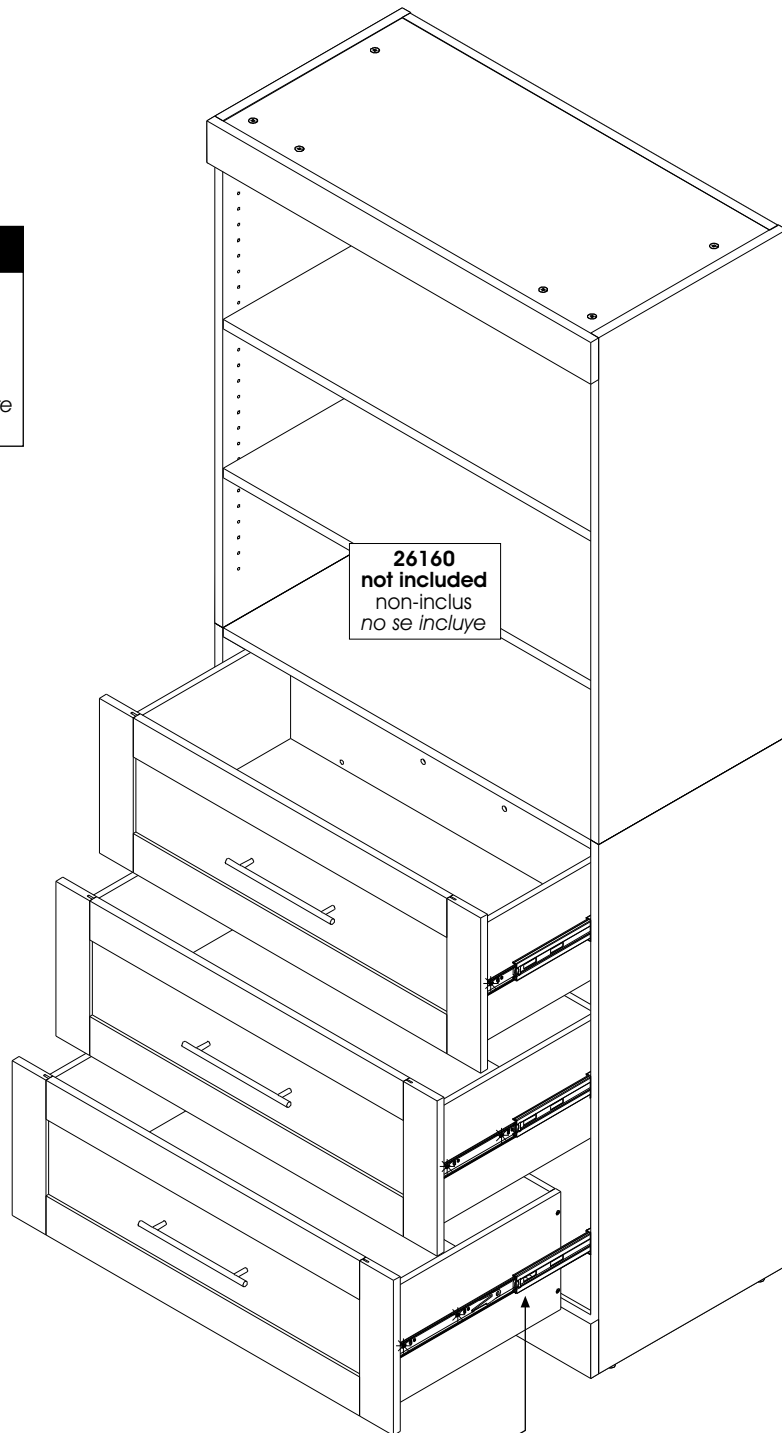

Important/Importante

Ball bearings must be on front part of slider when installing drawers.

Les roulements à billes doivent être sur la partie avant du coulisseau lors de l'installation des tiroirs.

Los cojinetes de bolas deben ubicarse sobre la parte delantera de guía en el momento de instalar los cajones.

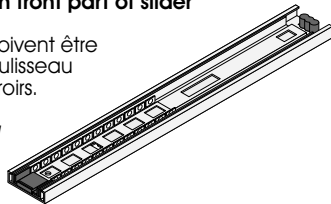

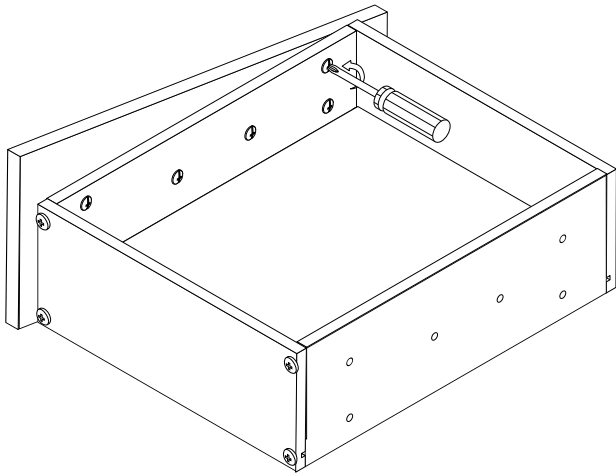

After installing drawers into cabinet, adjust drawer fronts and tighten screws VM-601.

Après avoir installé les tiroirs dans le meuble, ajustez les devants de tiroirs et resserrez les vis VM-601.

Después de instalar los cajones en el mueble, ajuste las partes delanteras de los cajones y vuelva a atornilla a fondo los tornillos VM-601.

PRODUCT CARE / ENTRETIEN DU PRODUIT / MANTENIMIENTO DEL PRODUCTO

Avoid placing the furniture in the sunlight or near a source of heat. Use a soft dry cloth for dusting. To clean heavy dirt, use a cloth dipped in a solution of mild detergent and water. Avoid leaving wet objects on the surface or using commercial chemical cleaning products.

Évitez d'exposer le meuble au soleil ou près de toute source de chaleur. Pour le nettoyage, utilisez un chiffon doux et sec. Pour la grosse saleté, utilisez un chiffon humidifié avec un peu de détergent dilué dans l'eau. Évitez de laisser des objets mouillés sur la surface de votre meuble ou d'utiliser des nettoyants chimiques.

Evite exponer el mueble al sol o las fuentes de calor. Para limpiarlo, utilice un paño suave y seco. Para limpiar las manchas rebeldes, utilice un trapo húmedo con un poco de detergente diluido en agua. No deje objetos mojados encima del mueble ni utilice limpiadores que contengan productos químicos. química.

CONGRATULATIONS! YOU ARE NOW THE OWNER OF A QUALITY PRODUCT
FÉLICITATIONS! VOUS AVEZ MAINTENANT EN VOTRE POSSESSION UN PRODUIT DE QUALITÉ
FELICITACIONES! AHORA ES USTED DUEÑO DE UN PRODUCTO DE CALIDAD.

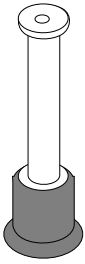

You are at a step of hardware installation and some H-36 are missing:

Before calling to order your missing bolts (H-36), please make sure you have not installed any bolts (H-36) in the wrong place. To remove a bolt (H-36) which is not in the correct place, please refer to your instruction manual.

Vous êtes à une étape d'installation de quincaillerie et il vous manque des H-36 :

Avant d'appeler pour commander des boulons (H-36), assurez-vous de ne pas avoir installé des boulons (H-36) au mauvais endroit. Pour enlever un boulon (H-36) mal situé, consultez le feuillet d'instructions.

Usted está en alguna etapa de la instalación de quincallas y le faltan las H-36 :

Antes de llamar para pedir los pernos (H-36), asegúrese de que no los haya instalado en el lugar equivocado.

Para retirar un perno (H-36) mal puesto, consulte el folleto de instrucciones.

How to separate and install your CO-249 and CO-684 slides:

The CO-249 & CO-684 slides consist of two sections which you must separate. To separate the slides, please refer to your instruction manual. The slides are installed on distinct parts which will be re-grouped only when the drawers are installed on the furniture.

Comment séparer et installer les coulisseaux CO-249 et CO-684 :

Les coulisseaux CO-249 et CO-684 sont constitués d'une partie que vous devez séparer en deux sections. Pour séparer le coulisseau, référez-vous au feuillet d'instructions. Les coulisseaux sont installés sur deux pièces distinctes et seront regroupés seulement lors de l'installation des tiroirs dans le meuble.

Cómo separar y instalar las guías correderas CO-249 y CO-684 :

Las guías correderas CO-249 y CO-684 están constituidas por una parte que usted debe separar en dos secciones. Para separar las guías correderas, consulte el folleto de instrucciones. Las guías correderas se instalan en dos piezas distintas y sólo serán reagrupadas una vez que se instalen los cajones en el mueble.

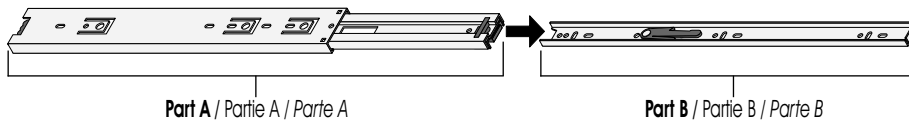

The doors on your furniture are crooked or the space between the doors is uneven:

It is very important to install the hinges and hinge plates on the correct parts while respecting the instruction manual.

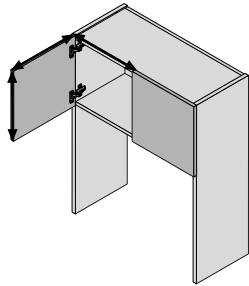

Les portes de votre meuble sont croches ou l'espace qui les sépare est inégal :

Il est important d'installer les pentures et les plaques sur les bonnes pièces en respectant le feuillet d'instructions.

Las puertas de su mueble están chuecas o el espacio que las separa es desigual :

Es importante instalar las bisagras y las placas sobre las piezas adecuadas respetando el folleto de instrucciones.

The drawers on your furniture are crooked or the space between the drawers is uneven:

While referring to the section indicating the actual sizes of the screws in your instruction manual , please insure that you are using the correct size screws needed when installing your drawer slides and drawer fronts. They must be installed straight. While installing the drawer front, make sure that the correct side is facing up.

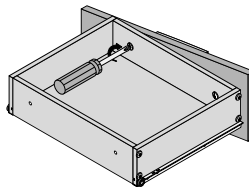

Les tiroirs de votre meuble sont croches ou l'espace qui les sépare est inégal :

En vous référant au tableau de vis grandeur réelle du feuillet d'instructions, assurez-vous que vous avez utilisé les bonnes vis lors de l'installation des coulisseaux ainsi que du devant de tiroir et qu'elles sont posées bien droites. Assurez-vous également que le devant du tiroir n'est pas assemblé à l'envers.

Los cajones de su mueble están chuecos o el espacio que los separa es desigual :

Consulte la tabla de tornillos en tamaño real del folleto de instrucciones y asegúrese de que haya utilizado los tornillos adecuados durante la instalación de las guías correderas así como también la parte delantera del cajón y que éstos estén puestos bien derechos. Asegúrese también de que la parte delantera del cajón no esté ensamblada al revés.



For more information or to discover our new products

Pour toute information ou pour découvrir nos nouveaux produits

Para obtener más información o para obtener nuevos productos



FOR LONG TIME
POUR LONGTEMPS
POR MUCHO TIEMPO



**OUR FURNITURE IS GARANTEED FOR 10 YEARS. NO MATTER THE PROBLEM,
OUR CUSTOMER SERVICE IS THERE FOR YOU.**

NOS MEUBLES SONT GARANTIS POUR 10 ANS. PEU IMPORTE LE PROBLÈME,
N'HÉSITÉZ PAS À COMMUNIQUER AVEC NOTRE SERVICE À LA CLIENTÈLE.

NUESTROS MUEBLES TIENEN UNA GARANTIA DE 10 AÑOS. NO IMPORTA EL PROBLEMA,
COMUNIQUE CON NUESTRO SERVICIO A CLIENTE.