

# **ASSEMBLY INSTRUCTION**

**ASSEMBLY TIPS:**

1. Remove hardware from box and sort by size.
2. Please check to see that all hardware and parts are present prior to start of assembly.
3. Please follow attached instructions in the same sequence as numbered to assure fast & easy assembly.



**Warning!**

1. Don't attempt to repair or modify parts that are broken or defective. Please contact the store immediately.
2. This product is for home use only and not intended for commercial establishment.

**PARTS IDENTIFICATION: Z HARDWARE PACKAGE**

(A) BACK  1PC

(B) SEAT  1PC

(C) RIGHT ARM  1PC

(D) LEFT ARM  1PC





(E) MECHANISM  1PC

(F) COVER FOR GAS LIFT  1PC

(G) GAS LIFT  1PC

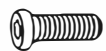
(H) BASE  1PC

(I) CASTER  5PCS

NO	DESCRIPTION	FIGURE	Q'TY
1	LONG BOLT		8PCS
2	SHORT BOLT		4PCS
3	ALLEN WRENCH		1PC
4	CAP		8PCS
5	WASHER		4PCS

**STEP 1**

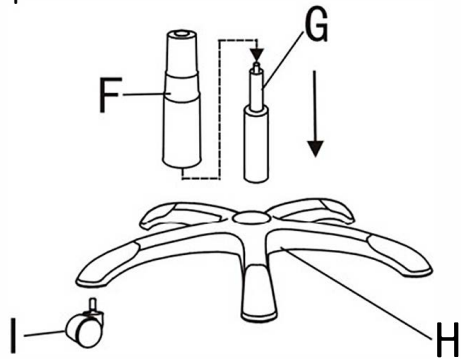

PUT GAS LIFT (G) INTO THE COVER FOR GAS LIFT (F) AND THEN ATTACH CASTER (I) TO BASE (H)

**STEP 2**

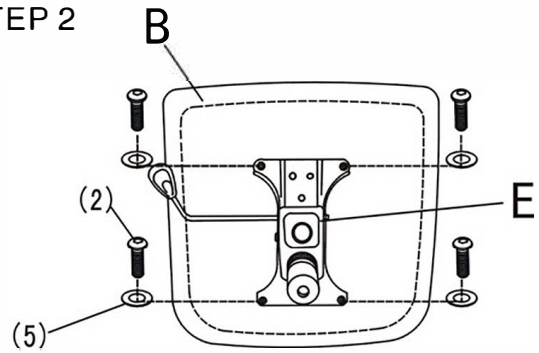

ATTACH THE MECHANISM (E) TO THE SEAT (B) WITH WASHER (5) AND SHORT BOLT (2). TIGHTEN WITH ALLEN WRENCH (3).

**STEP 3**

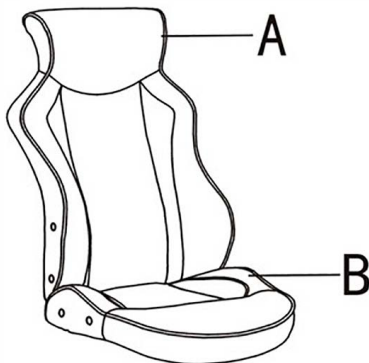

ALIGN THE BACK (A) TO THE SEAT (B)

**STEP 4**

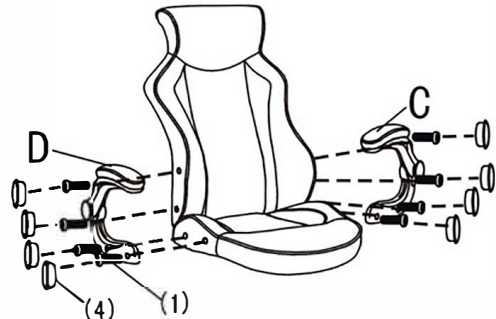

ATTACH THE RIGHT ARM AND LEFT ARM (C & D) TO THE SEAT AND BACK WITH LONG BOLTS (1). TIGHTEN WITH ALLEN WRENCH. COVER BOLTS WITH CAPS (4).

**STEP 5**

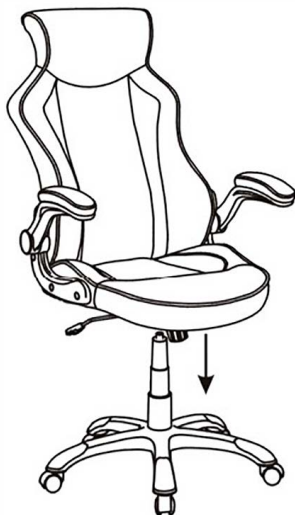

ATTACH THE CHAIR TO THE GASLIFT (G)

**STEP 6**

