

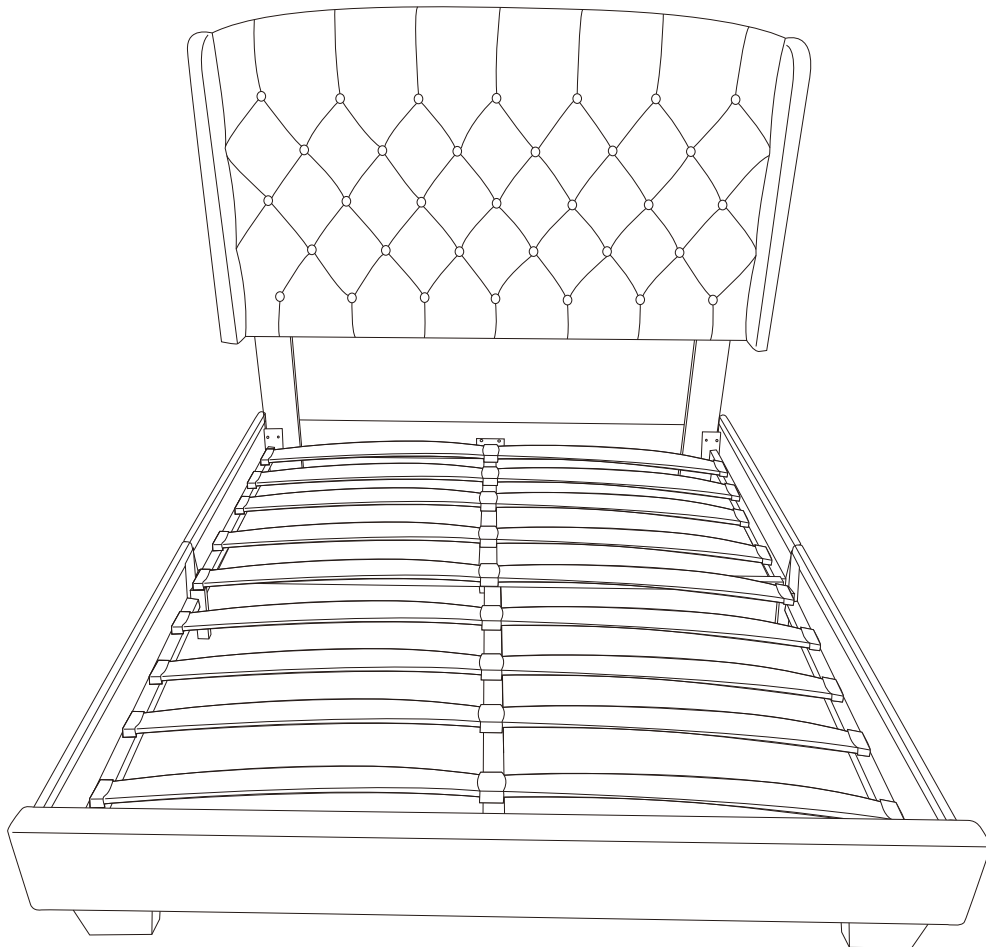









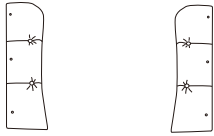
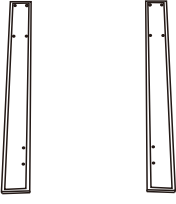

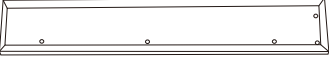
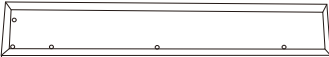

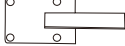

stylor bed





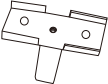





ASSEMBLY INSTRUCTION

PartsList

<p>A</p>  <p>x1</p>	<p>B</p>  <p>B(L)x1 B(R)x1 x1</p>	<p>C</p>  <p>C(L)x1 C(R)x1 x2</p>	<p>D</p>  <p>x1</p>
<p>E</p>  <p>x2</p>	<p>F</p>  <p>x2</p>	<p>G</p>  <p>x2</p>	<p>H</p>  <p>x2</p>
<p>I</p>  <p>x1</p>	<p>J</p>  <p>x2</p>	<p>K</p>  <p>x20</p>	<p>L</p>  <p>Legs x2</p>
<p>M</p>  <p>Single holes x20</p>	<p>N</p>  <p>Both holes x10</p>	<p>O</p>  <p>x1</p>	<p>P</p>  <p>x1</p>
<p>Q</p>  <p>Long x1</p>	<p>R</p>  <p>Short x1</p>		

HardwareList

<p>① M4x55</p>  <p>4pcs</p>	<p>② M6x45</p>  <p>14pcs</p>	<p>③ M6x40</p>  <p>21pcs</p>	<p>④ M6x30</p>  <p>10pcs</p>
<p>⑤ M6x16</p>  <p>10pcs</p>	<p>⑥</p>  <p>2pcs</p>	<p>⑦</p>  <p>20pcs</p>	<p>⑧</p>  <p>1pc</p>

ASSEMBLY INSTRUCTION

1

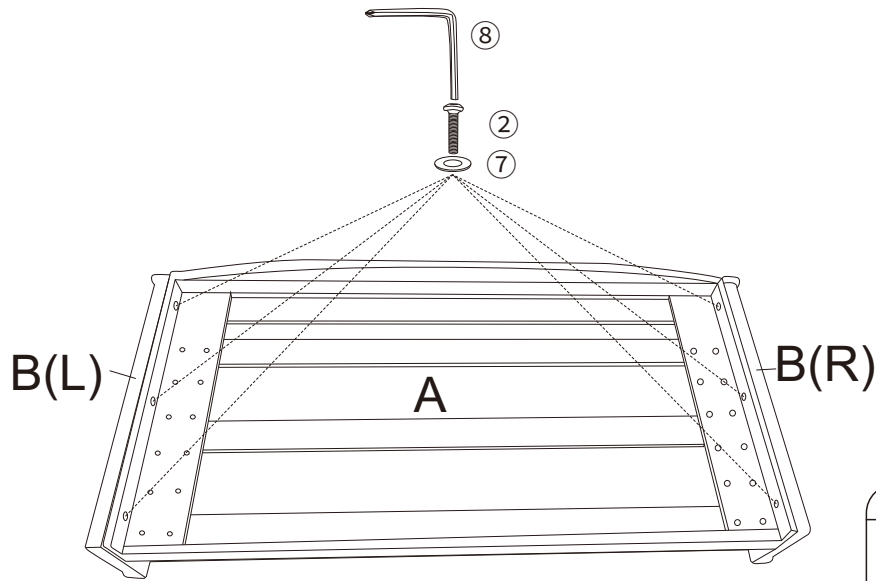

2

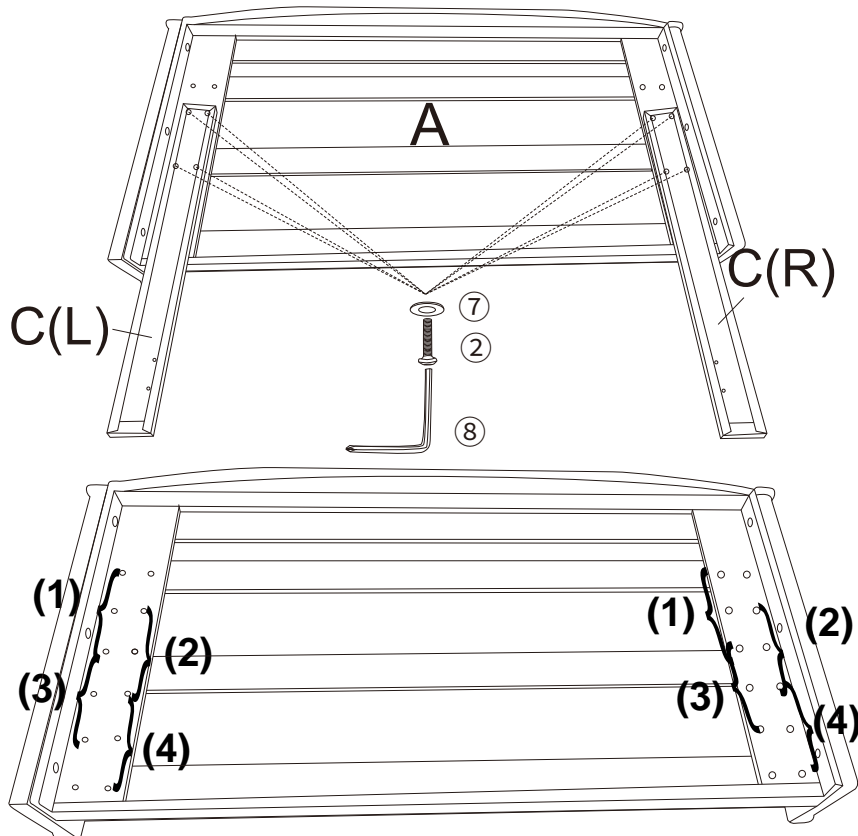

For the convenience of installation, please lock 50% of all screws in this step, and then lock 100% after step 3 is completed
 Part C(L) and Part C(R) is installed onto Part A as shown in the figure.
 And there are four installation methods to adjust the height of the bed.
 Adjustable bed height range: 1.2m-1.5m (manual measurement: ± 2 cm)

3

ASSEMBLY INSTRUCTION

3

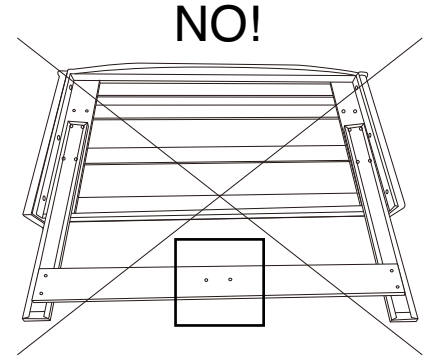
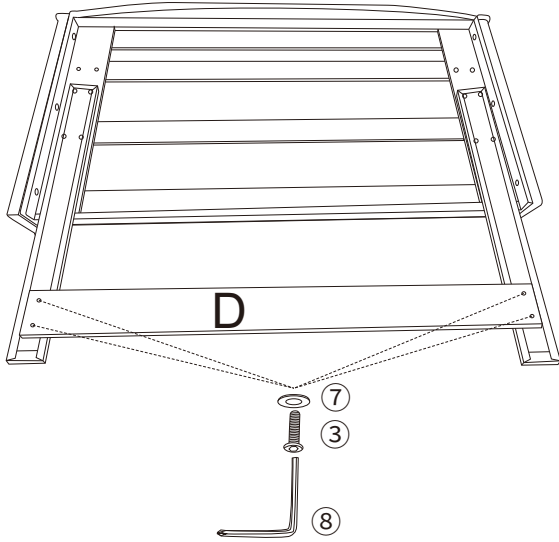

When installing the Part D, pay attention to distinguish between the front and the back. There are two holes in the middle of the front.

③	4	⑦	4
M6x40			

4

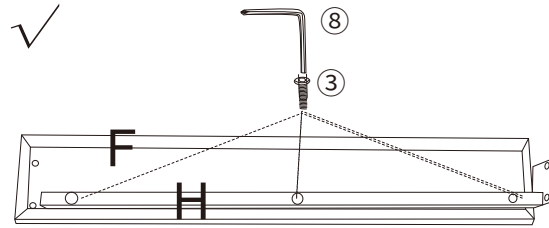
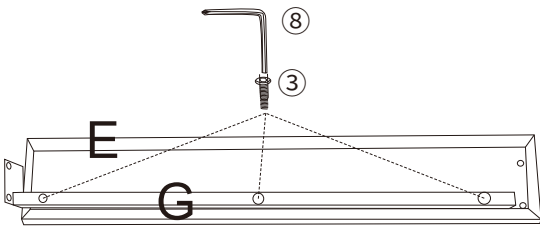

X2

③	12
M6x40	

NO! X

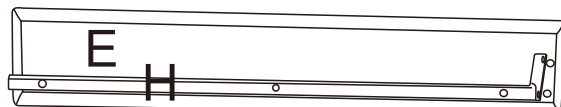
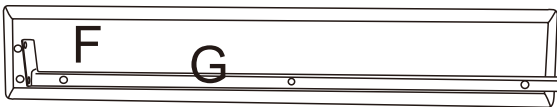
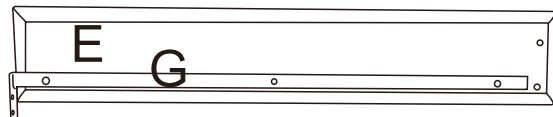
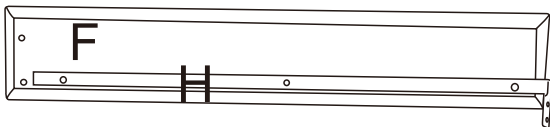

5

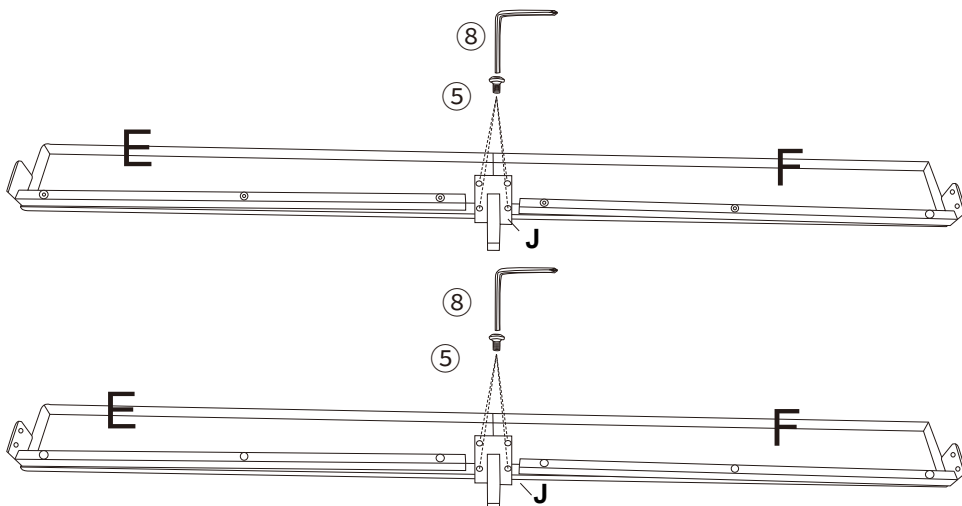

⑤	8
M6x16	

ASSEMBLY INSTRUCTION

6

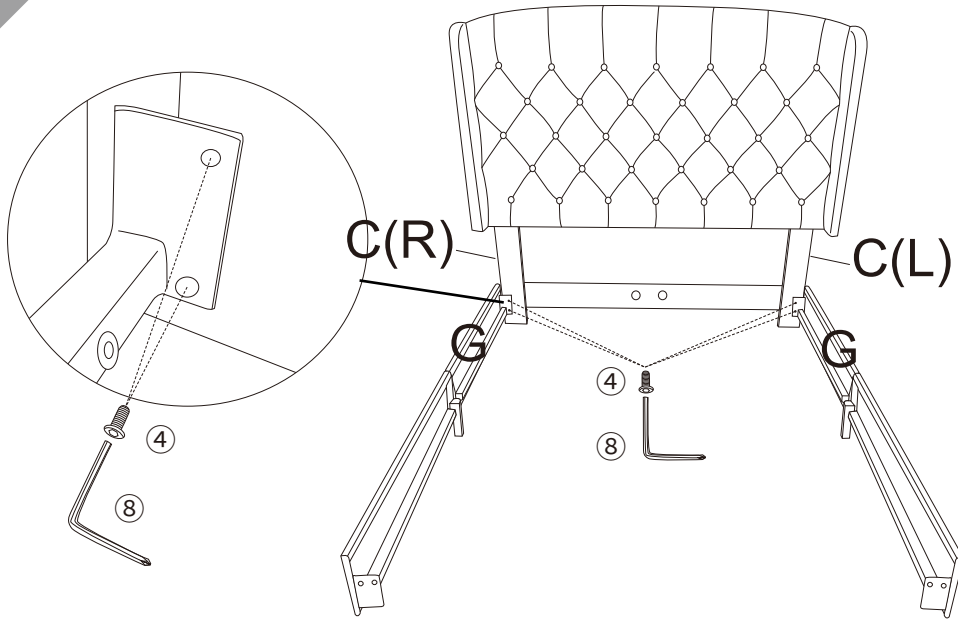

4	4
M6x30	

7

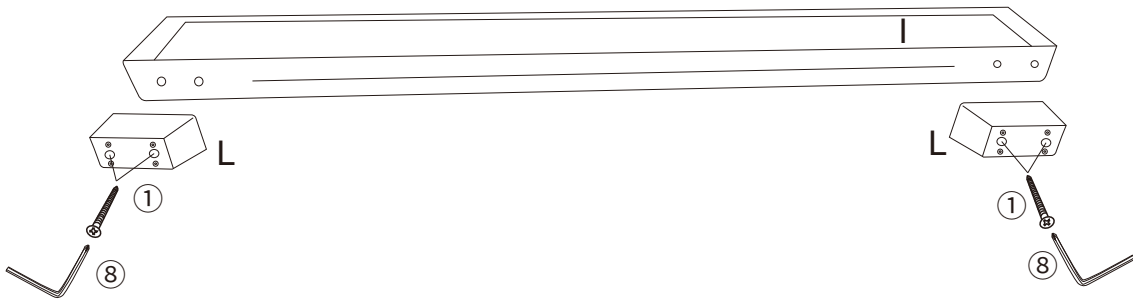

1	4
M4x55	

8

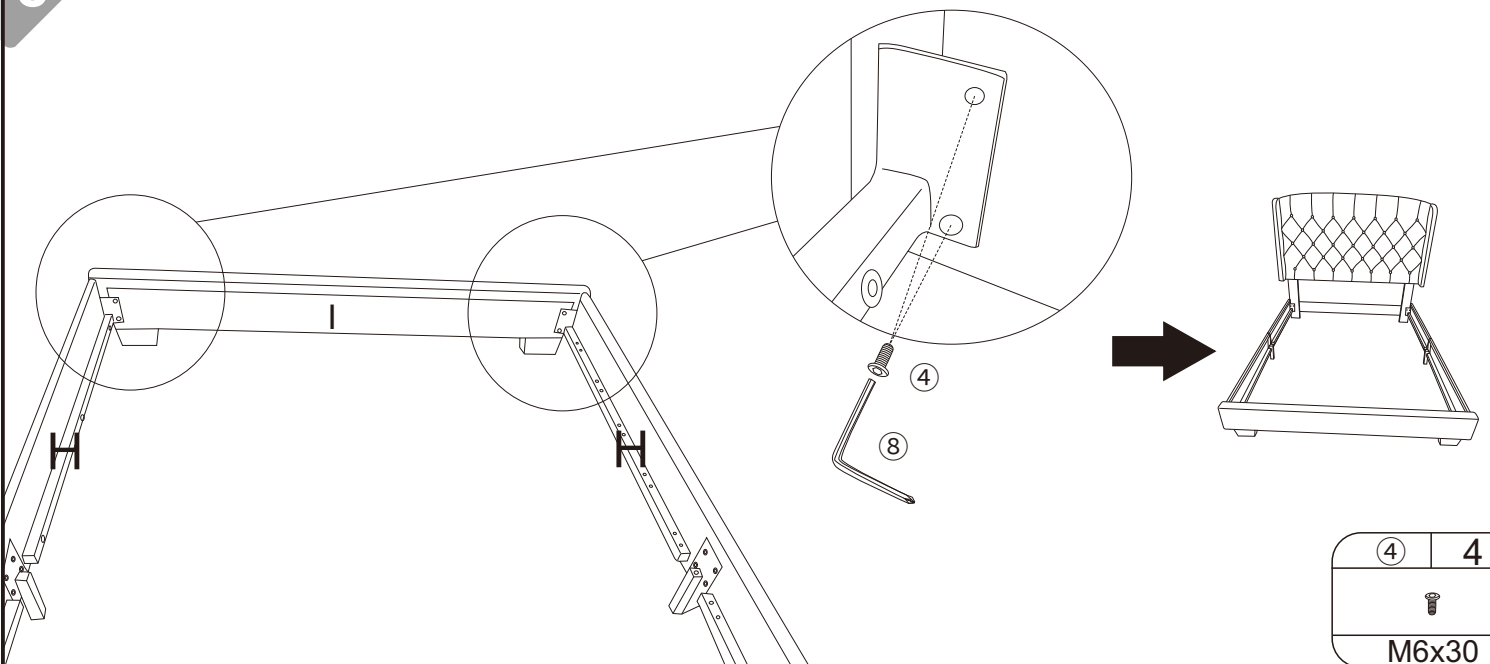



4	4
M6x30	

ASSEMBLY INSTRUCTION

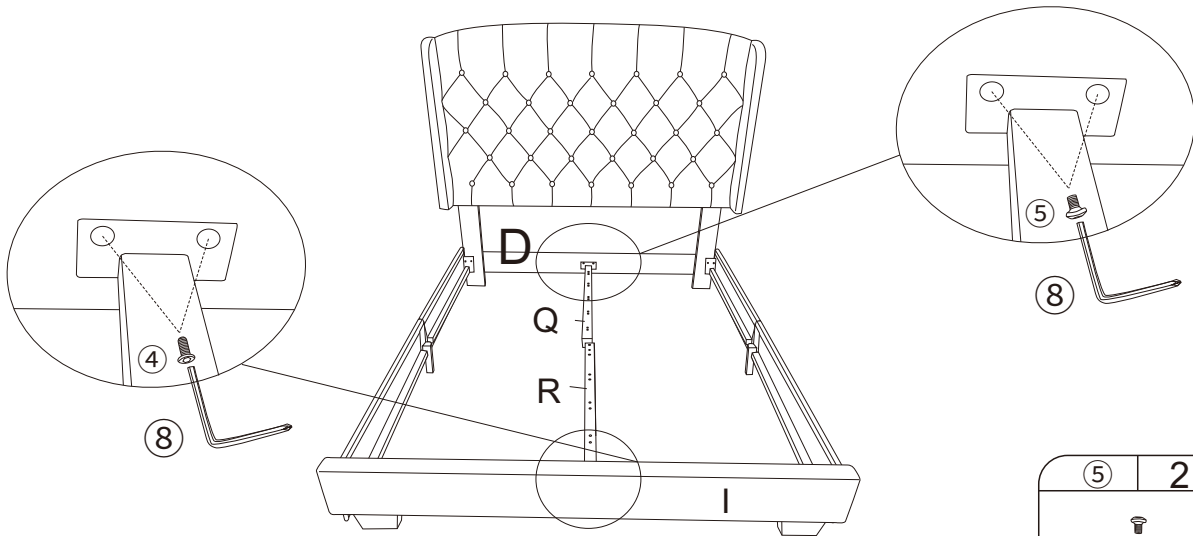

9

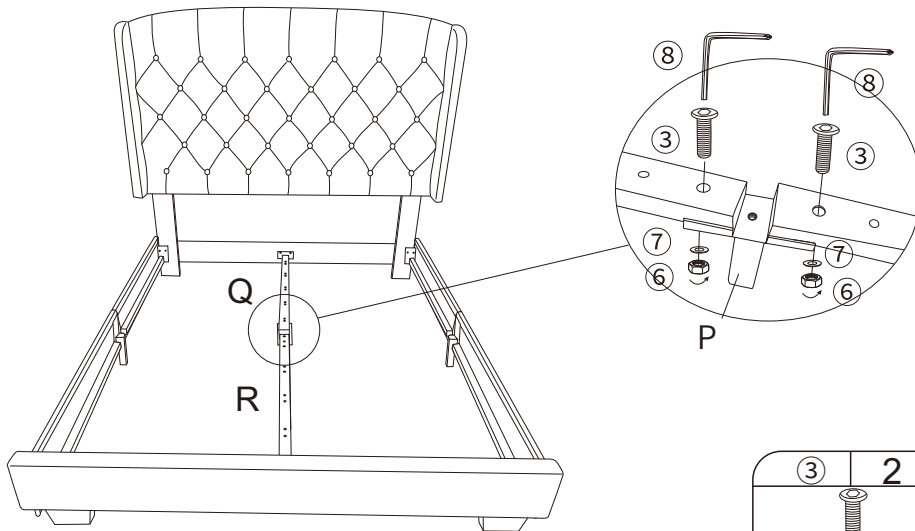

⑤	2	④	2
			
M6x16		M6x30	

10



③	2	⑦	2	⑥	2
					
M6x40					

11

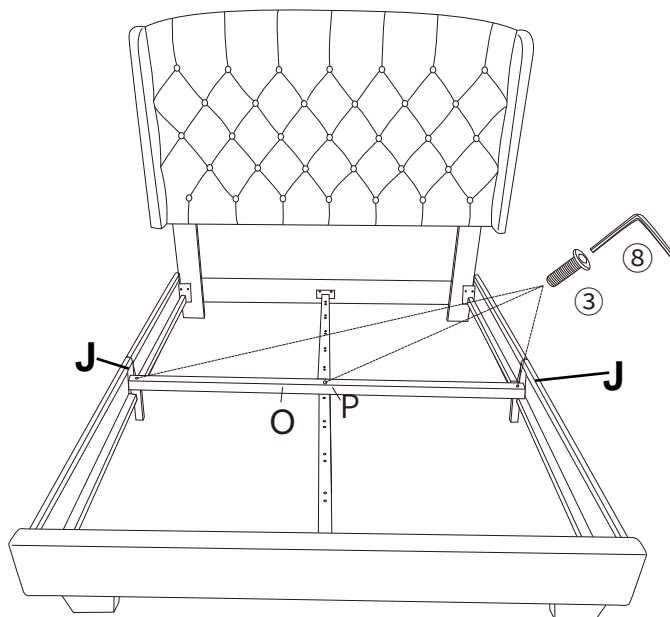

③	3
	
M6x40	

ASSEMBLY INSTRUCTION

12

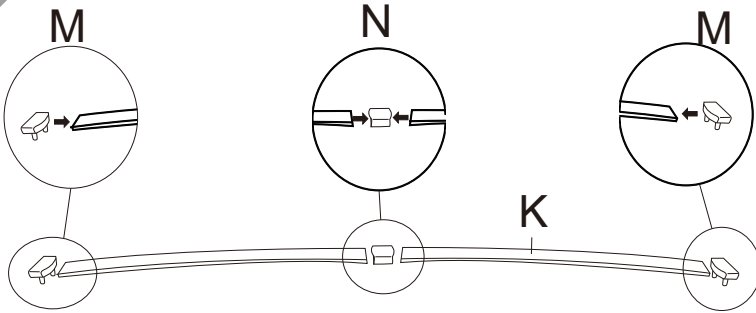

X10

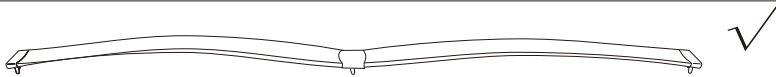

NO!

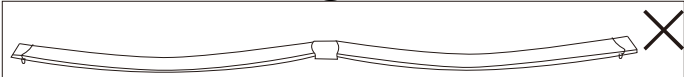

13

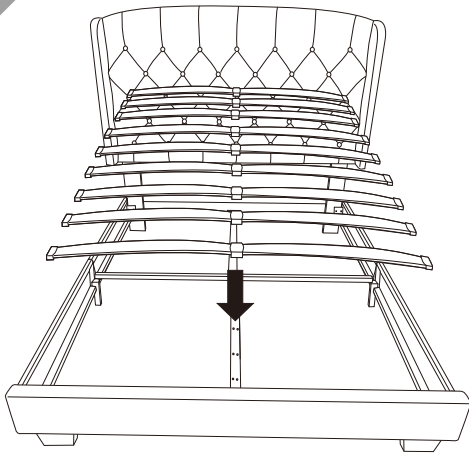

Attention:
on the side

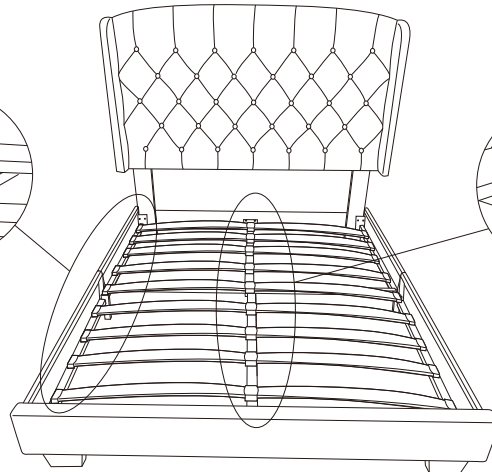
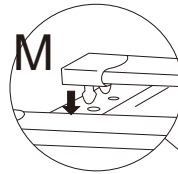

Attention:
on the middle

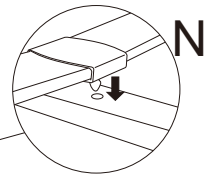

14

