

# Assembly | Asambla | Assemblage

PO# 155592

Customer service | Servicio al cliente | Service clientèle: 800.633.5096/972.869.0111

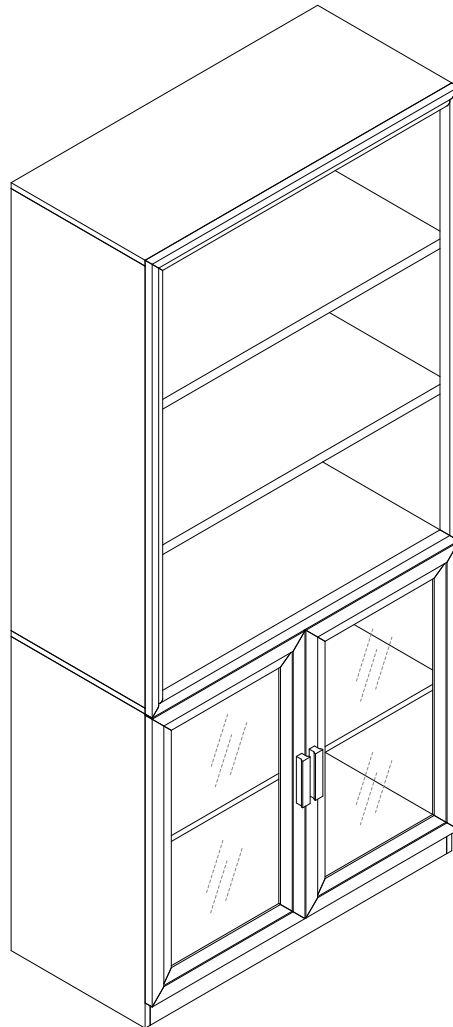

Product number | Número de producto | Numéro de produit

**CM060003**

Thank you for your purchase! | ¡Gracias por tu compra! | Merci pour votre achat!

# Assembly | Asambla | Assemblage

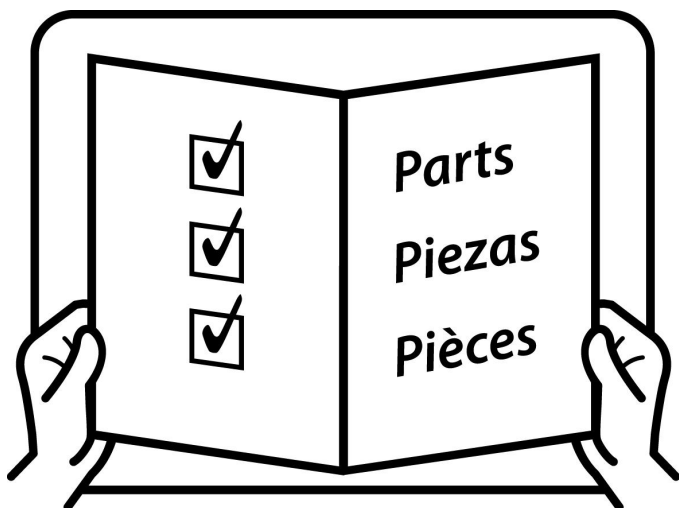
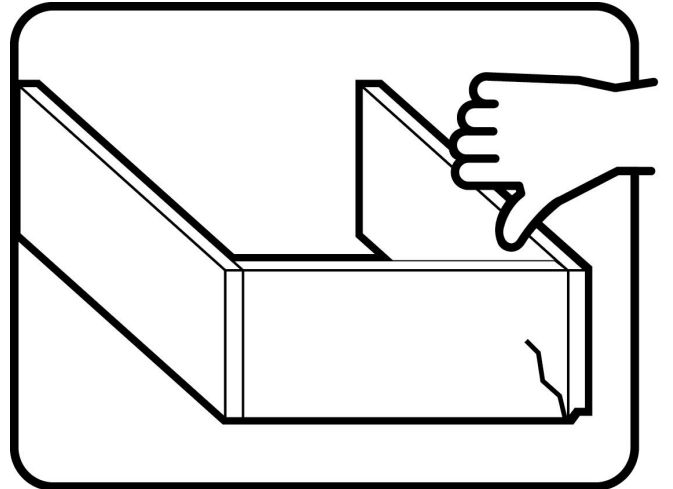
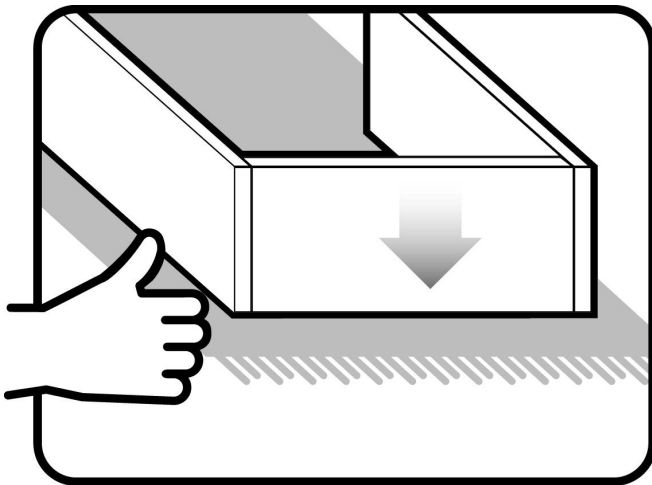
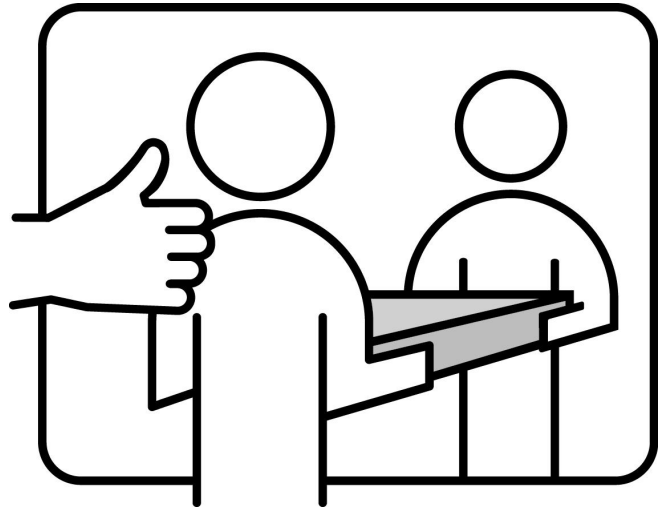
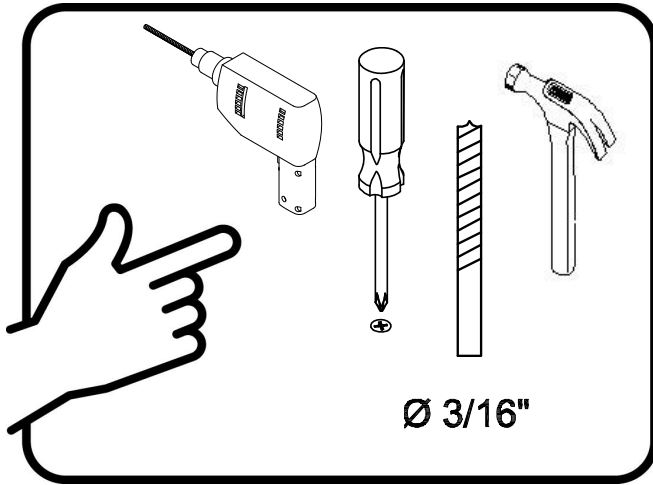

# Assembly | Asamblea | Assemblage

Techniques | Técnicas | Techniques

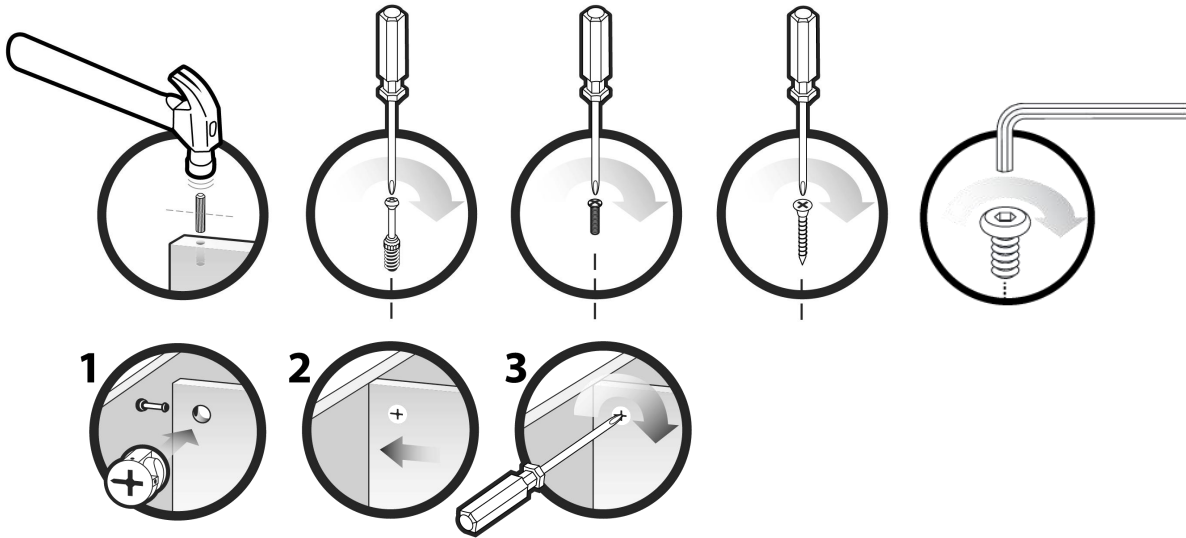

Care | Cuidado | Entretien

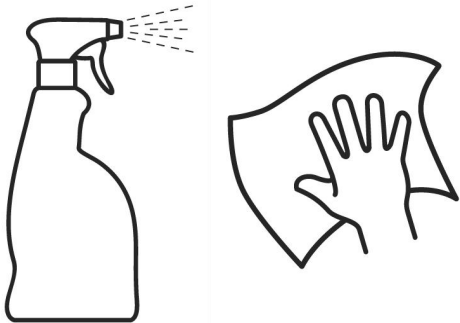

Safety | Seguridad | Sécurité



Note! | ¡Nota! | Remarque!

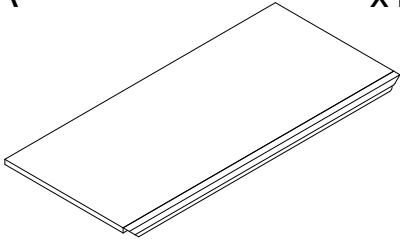
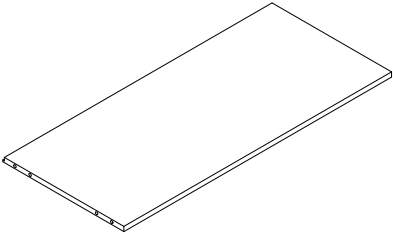
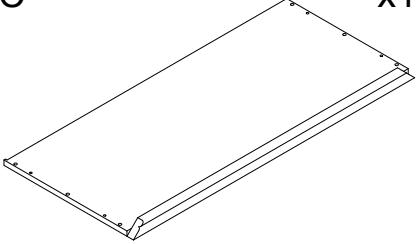
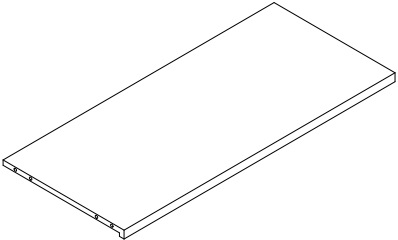
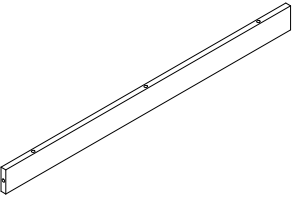
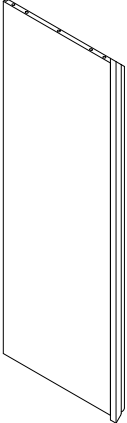
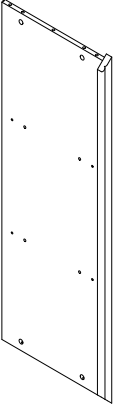
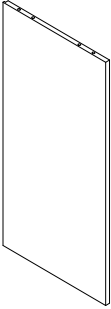
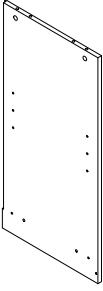

# Assembly | Asambla | Assemblage

<p><b>A</b> <span style="float: right;">x1</span></p>  <p><b>Upper Top panel</b> Panel superior Panneau supérieur supérieur</p>	<p><b>B</b> <span style="float: right;">x1</span></p>  <p><b>Bottom panel</b> Panel inferior Panneau inférieur</p>	<p><b>C</b> <span style="float: right;">x1</span></p>  <p><b>Lower Top panel</b> Panel superior inferior Panneau supérieur inférieur</p>
<p><b>D</b> <span style="float: right;">x2</span></p>  <p><b>Fixed shelf panel</b> Panel de estante fijo Panneau d'étagère fixe</p>	<p><b>E</b> <span style="float: right;">x1</span></p>  <p><b>Front Panel</b> Panel frontal Panneau</p>	<p><b>F</b> <span style="float: right;">x1</span></p>  <p><b>Upper Left side panel</b> Panel lateral superior izquierdo Panneau latéral supérieur gauche</p>
<p><b>G</b> <span style="float: right;">x1</span></p>  <p><b>Upper Right side panel</b> Panel lateral superior derecho Panneau latéral supérieur droit</p>	<p><b>H</b> <span style="float: right;">x1</span></p>  <p><b>Lower Left side panel</b> Panel lateral inferior izquierdo Panneau latéral inférieur gauche</p>	<p><b>I</b> <span style="float: right;">x1</span></p>  <p><b>Lower Right side panel</b> Panel lateral inferior derecho Panneau latéral inférieur droit</p>

# Assembly | Asambla | Assemblage

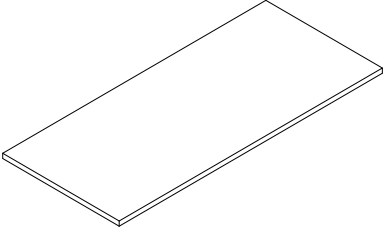
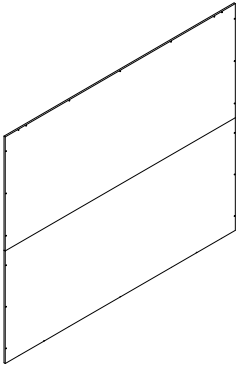
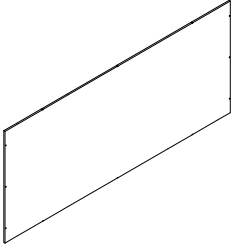
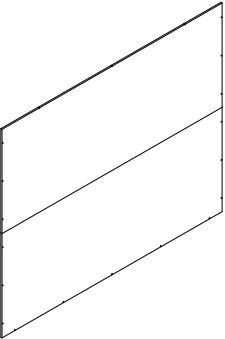
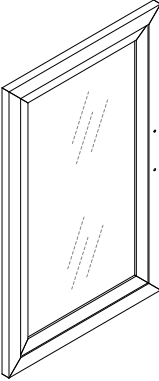
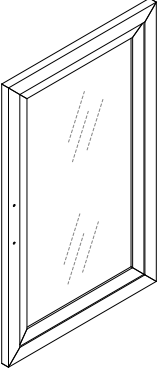
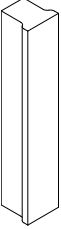
<p><b>J</b> <span style="float: right;"><b>x1</b></span></p>  <p><b>Adjustable Shelf Panel</b> Panel de estante ajustable Panneau d'étagère réglable</p>	<p><b>K</b> <span style="float: right;"><b>x1</b></span></p>  <p><b>Upper Back panel</b> Panel trasero superior Panneau dorsal supérieur</p>	<p><b>L</b> <span style="float: right;"><b>x1</b></span></p>  <p><b>Middle Back panel</b> Panel trasero central Panneau arrière central</p>
<p><b>M</b> <span style="float: right;"><b>x1</b></span></p>  <p><b>Lower Back panel</b> Panel trasero inferior Panneau inférieur du dos</p>	<p><b>N</b> <span style="float: right;"><b>x1</b></span></p>  <p><b>Left door</b> Puerta izquierda Porte gauche</p>	<p><b>O</b> <span style="float: right;"><b>x1</b></span></p>  <p><b>Right door</b> Puerta derecha Porte droite</p>
<p><b>P</b> <span style="float: right;"><b>x2</b></span></p>  <p><b>Wooden handle</b> Mango de madera Poignée en bois</p>		

# Assembly | Asamblea | Assemblage

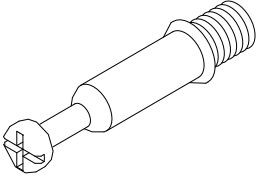
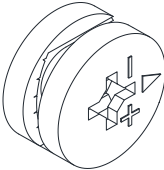
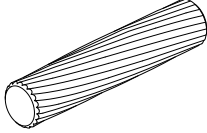
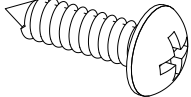
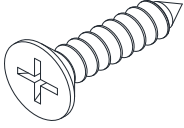
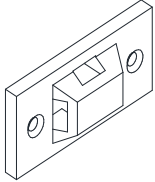
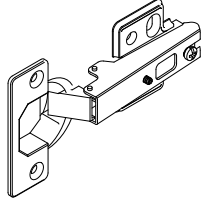
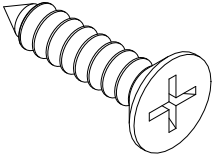
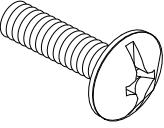
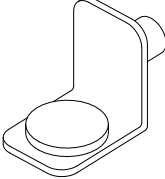
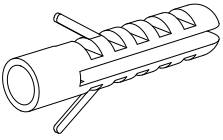
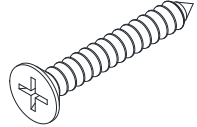
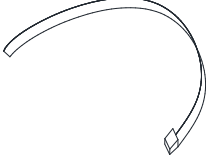
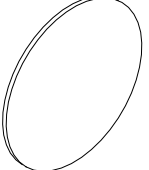
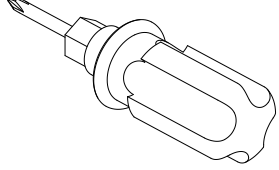
<p>1 x29</p>  <p>Cam bolt Perno de leva Boulon à came</p>	<p>2 x29</p>  <p>Cam lock Bloqueo de leva Serrure à came</p>	<p>3 x28</p>  <p>Wood dowel Clavija de madera Cheville en bois Ø5/16"x1-1/4"L</p>	<p>4 x44</p>  <p>Screw Tornillo Vis Ø1/8"*5/8"L</p>
<p>5 x4</p>  <p>Screw Tornillo Vis Ø1/8"*5/8"L</p>	<p>6 x4</p>  <p>Bracket Paréntesis Parenthèse</p>	<p>7 x4</p>  <p>Hinge Bisagra Charnière</p>	<p>8 x24</p>  <p>Screw Tornillo Vis Ø1/8"*5/8"L</p>
<p>9 x4</p>  <p>Small bolt Tornillo pequeño Petit boulon Ø5/32"x3/4"L</p>	<p>10 x4</p>  <p>Shelf holder Estante titular Support d'étagère</p>	<p>11 x4</p>  <p>Anchor Ancla Ancre</p>	<p>12 x4</p>  <p>Screw Tornillo Vis Ø1/4"*1-3/8"L</p>
<p>13 x2</p>  <p>Tie Atar Attacher</p>	<p>14 x20</p>  <p>Cover Tapa Couverture</p>	<p>15 x1</p>  <p>Screwdriver Destornillador Tournevis</p>	

# Assembly | Asambla | Assemblage

1

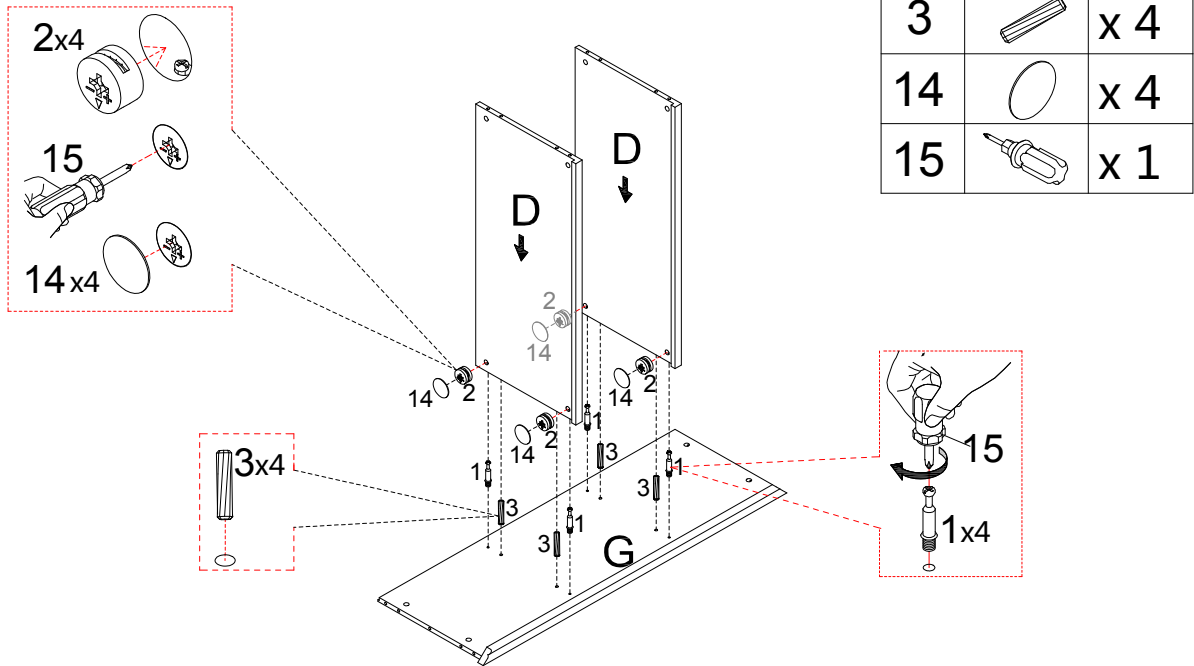

2

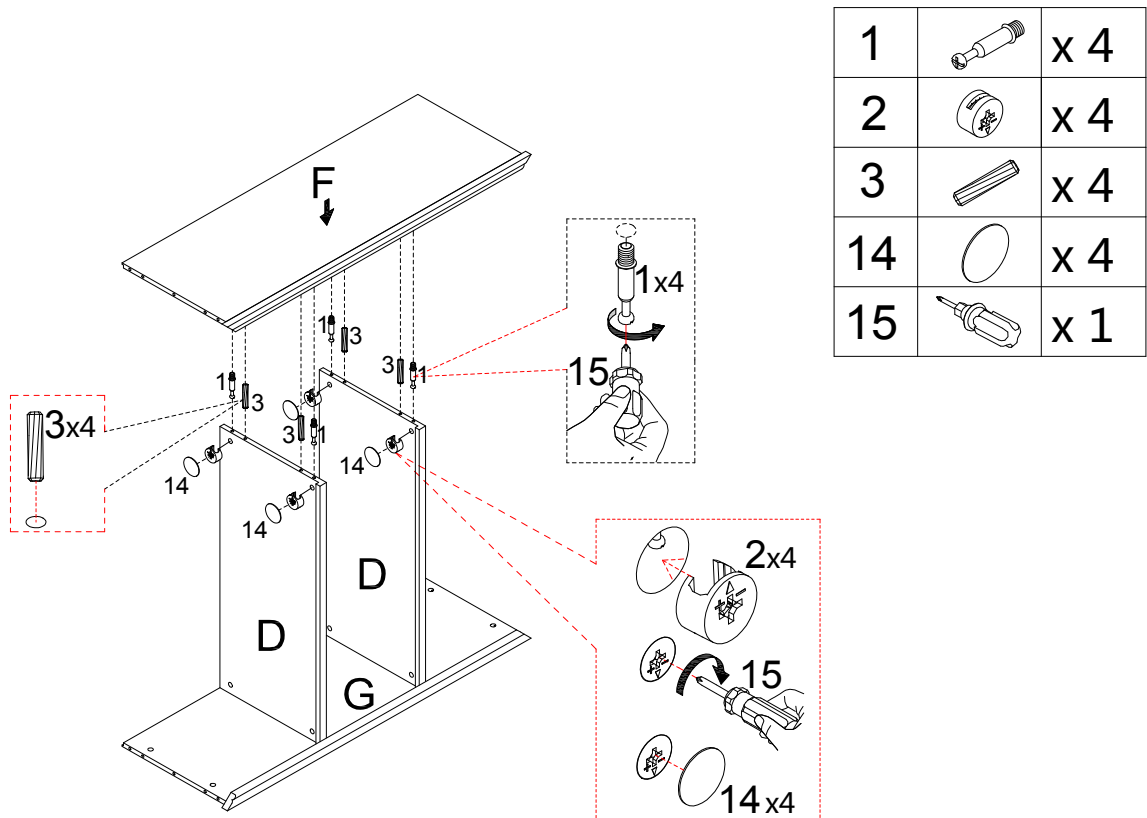

# Assembly | Asambla | Assemblage

## 3

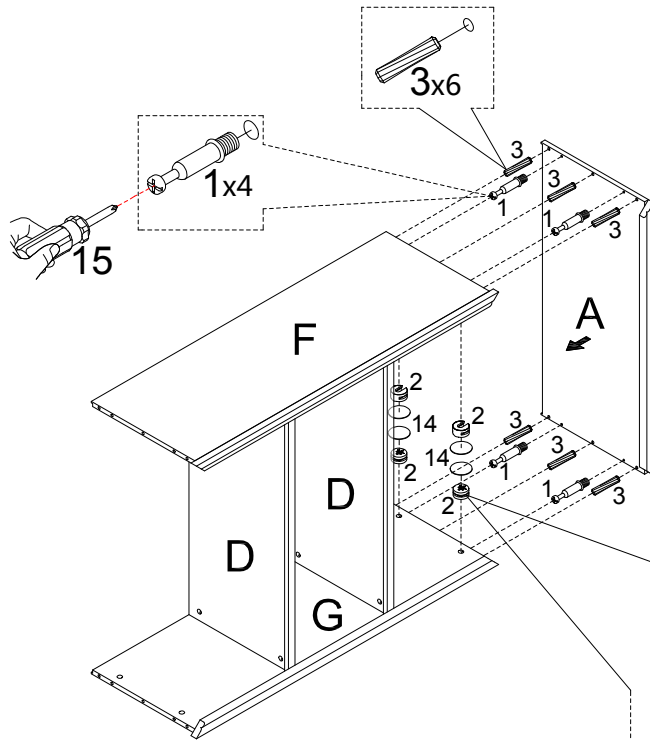

1		x 4
2		x 4
3		x 6
14		x 4
15		x 1

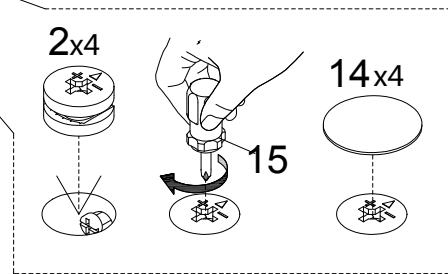

## 4

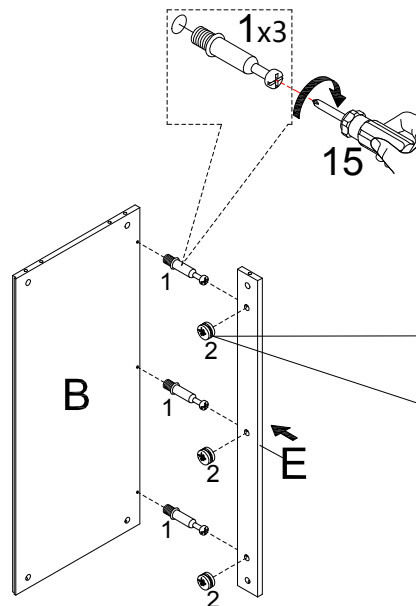

1		x 3
2		x 3
15		x 1

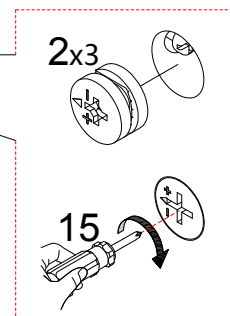

# Assembly | Asambla | Assemblage

5

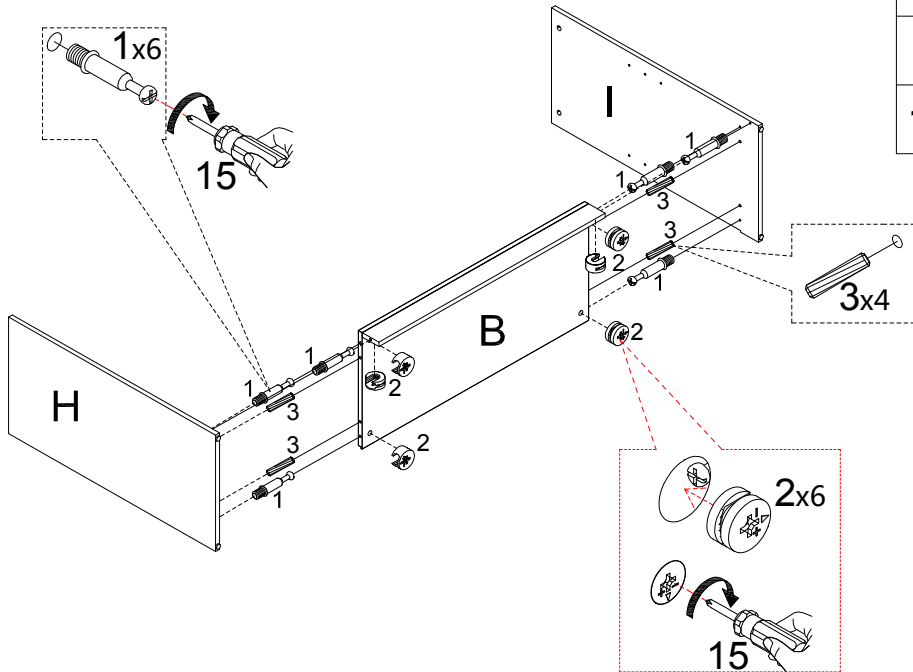

1		x 6
2		x 6
3		x 4
15		x 1



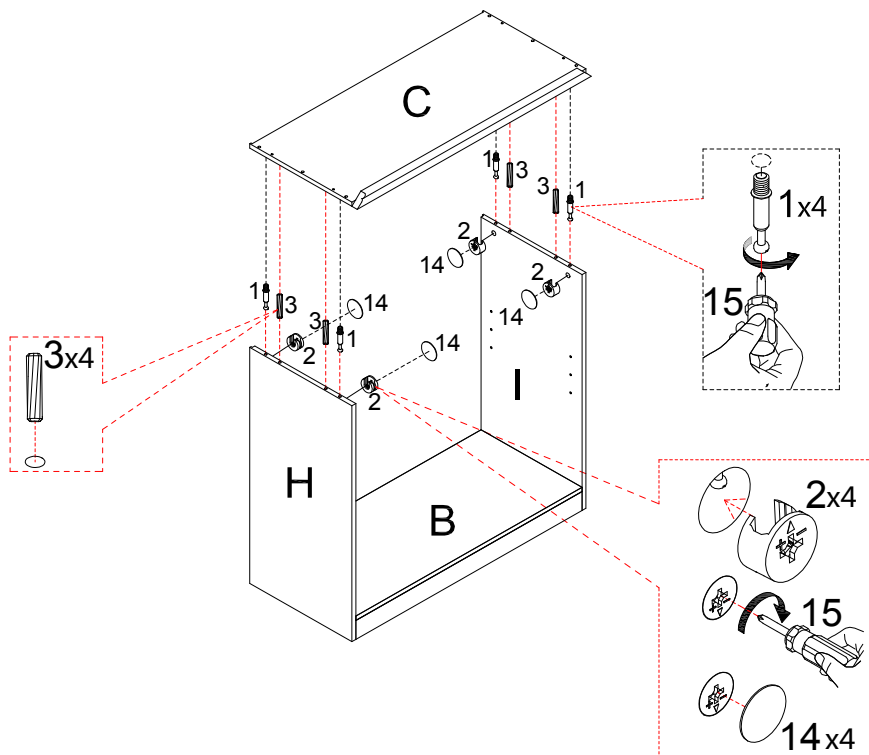

6



1		x 4
2		x 4
3		x 4
14		x 4
15		x 1

# Assembly | Asambla | Assemblage



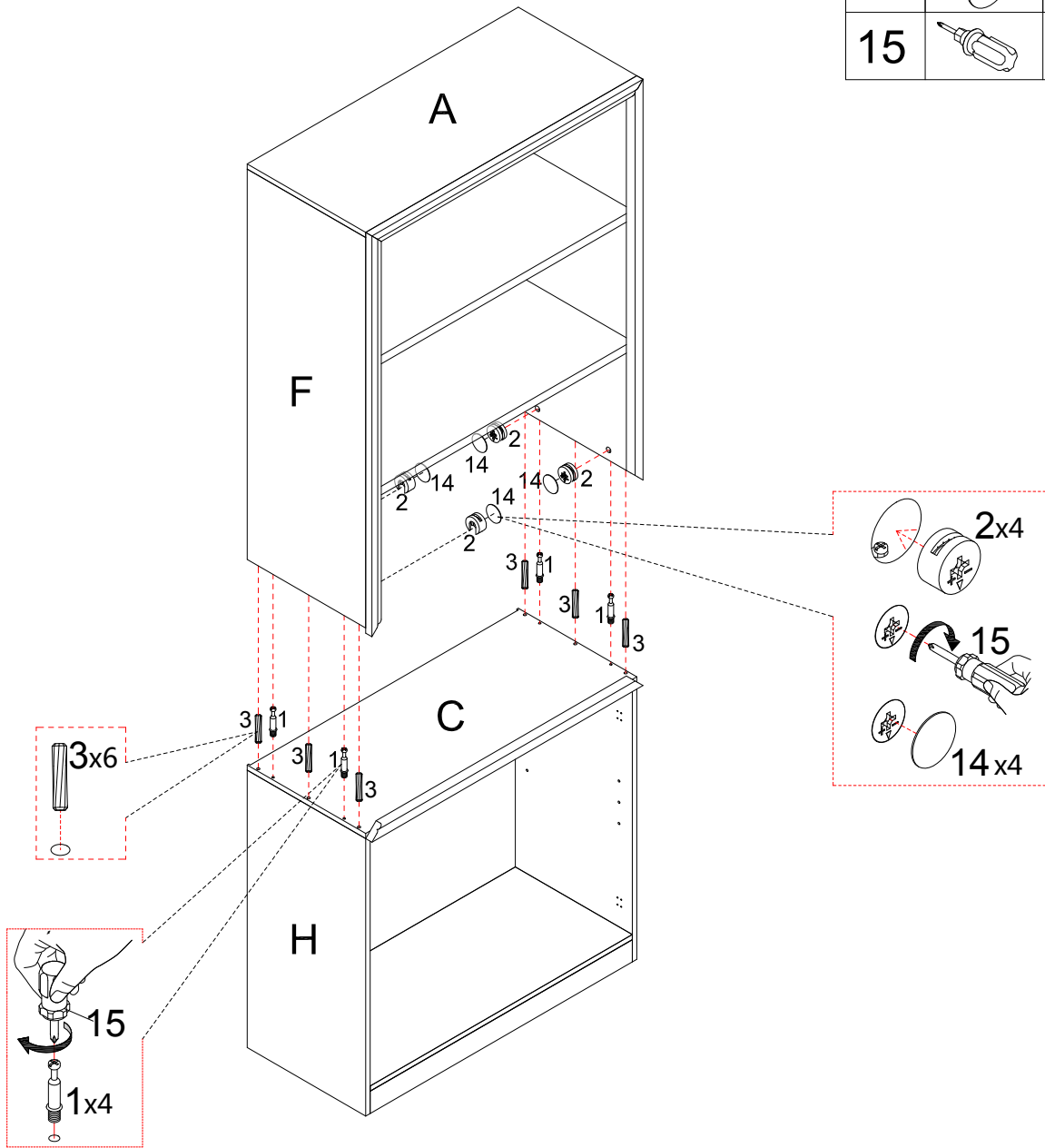

7

1		x 4
2		x 4
3		x 6
14		x 4
15		x 1

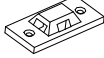

# Assembly | Asambla | Assemblage

8

4		x 44
5		x 4
6		x 2
15		x 1

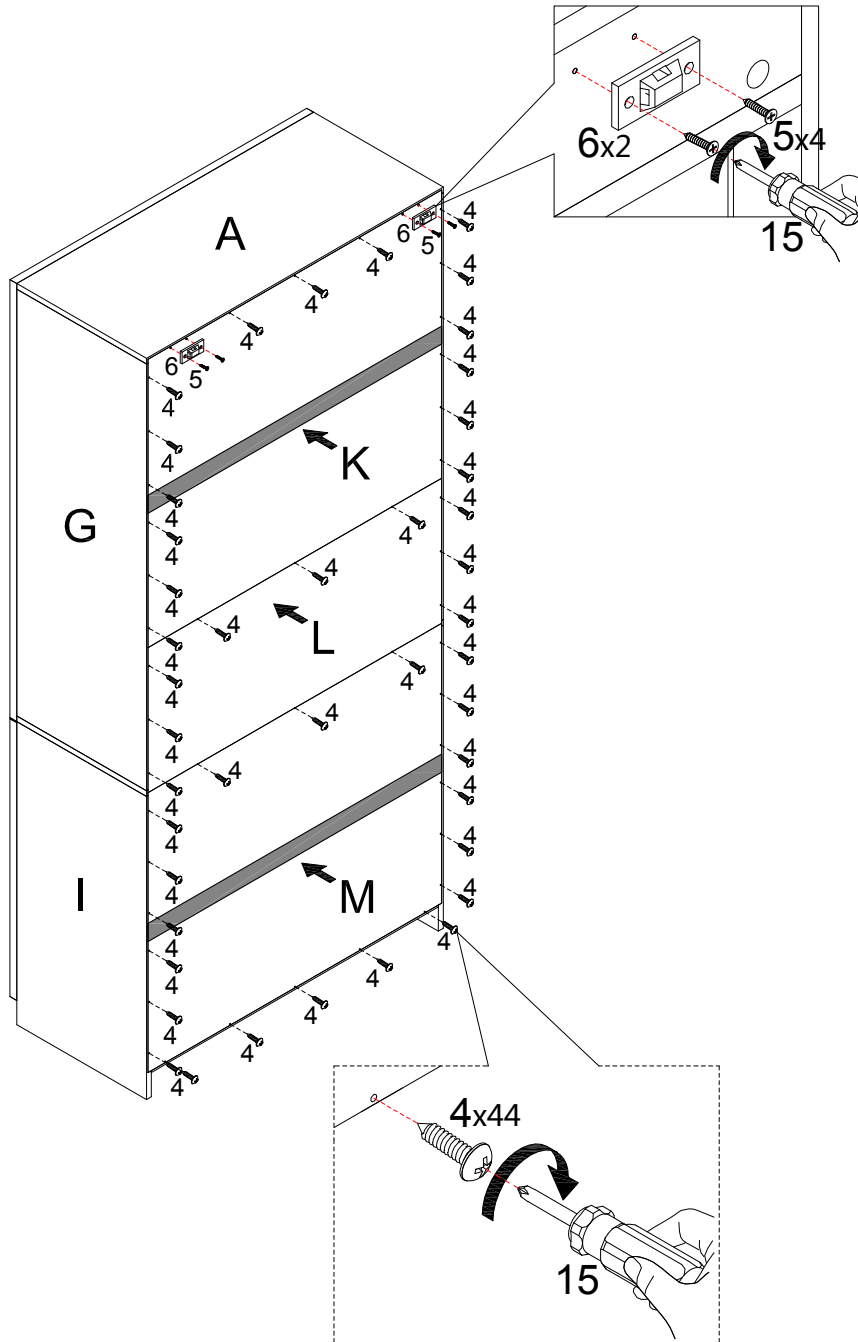

# Assembly | Asambla | Assemblage

9

10



x 4

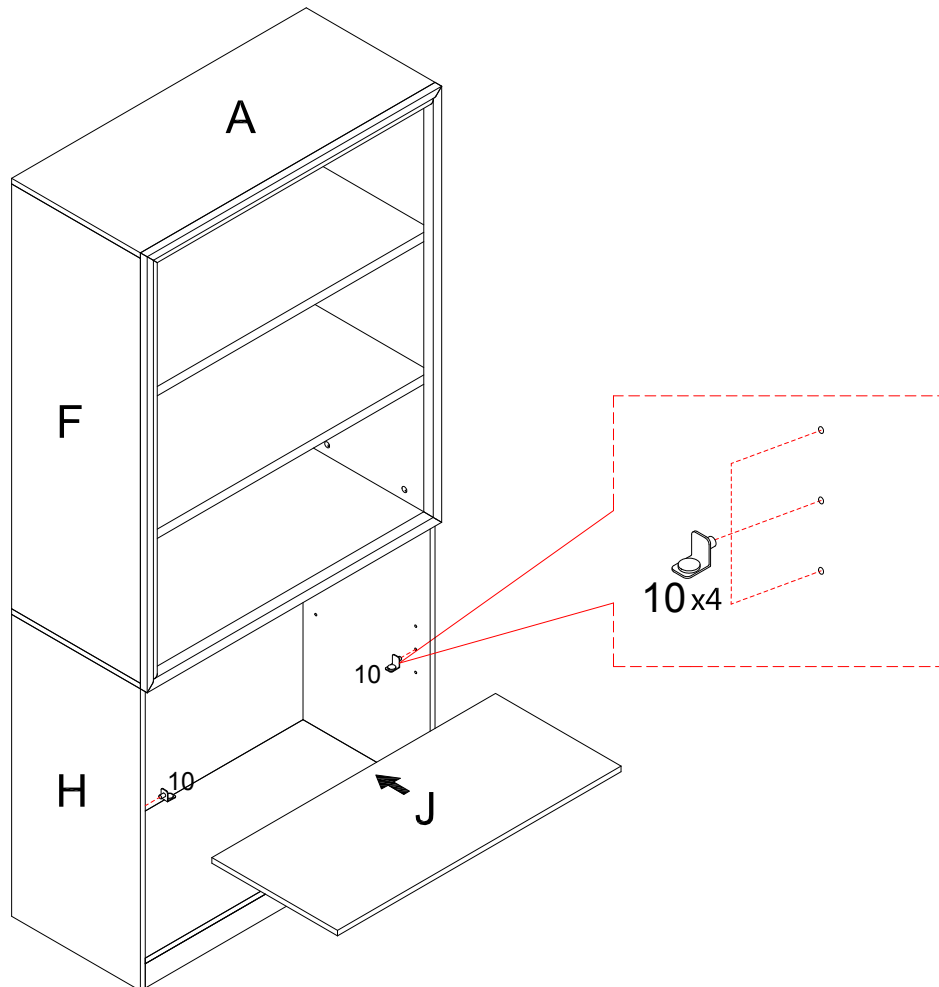

Shelf Holder can be adjusted up or down  
El soporte del estante se puede ajustar hacia arriba o hacia abajo  
support d'étagère peut être ajusté vers le haut ou vers le bas

# Assembly | Asambla | Assemblage

## 10

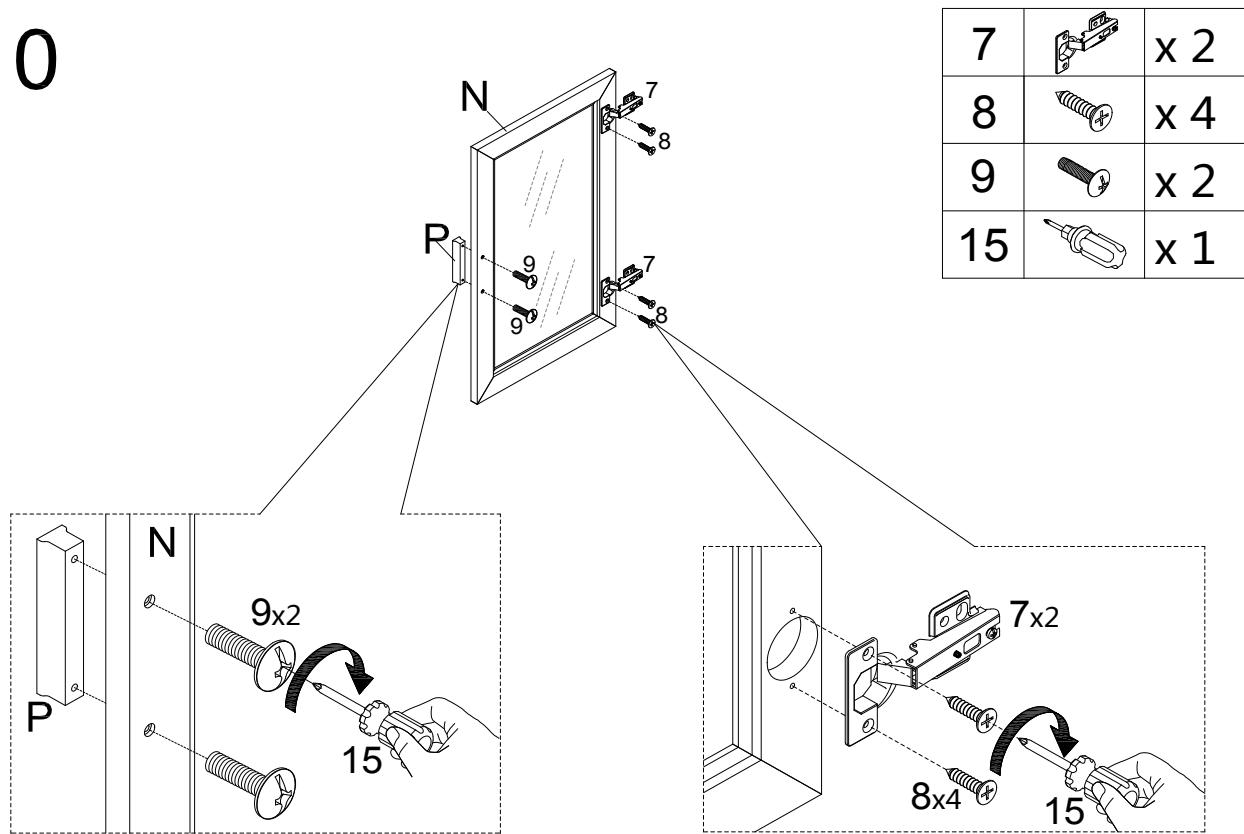

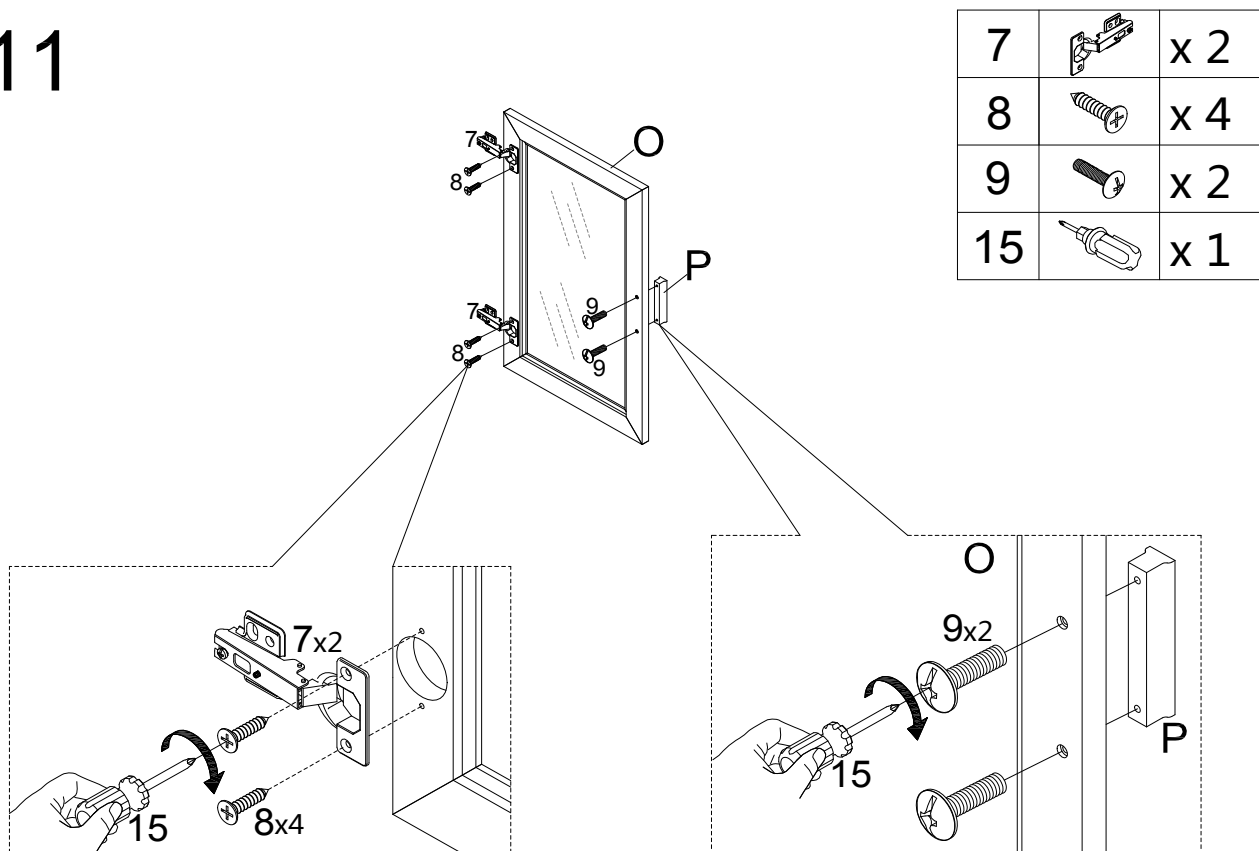

## 11



# Assembly | Asambla | Assemblage

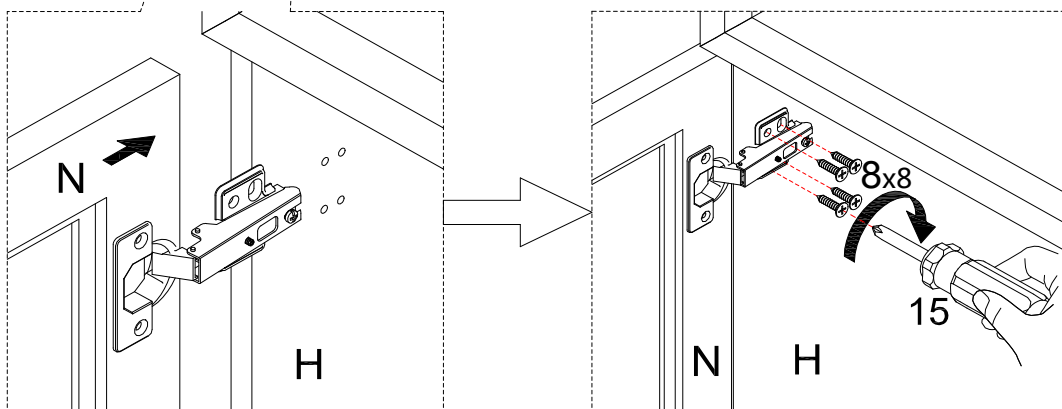
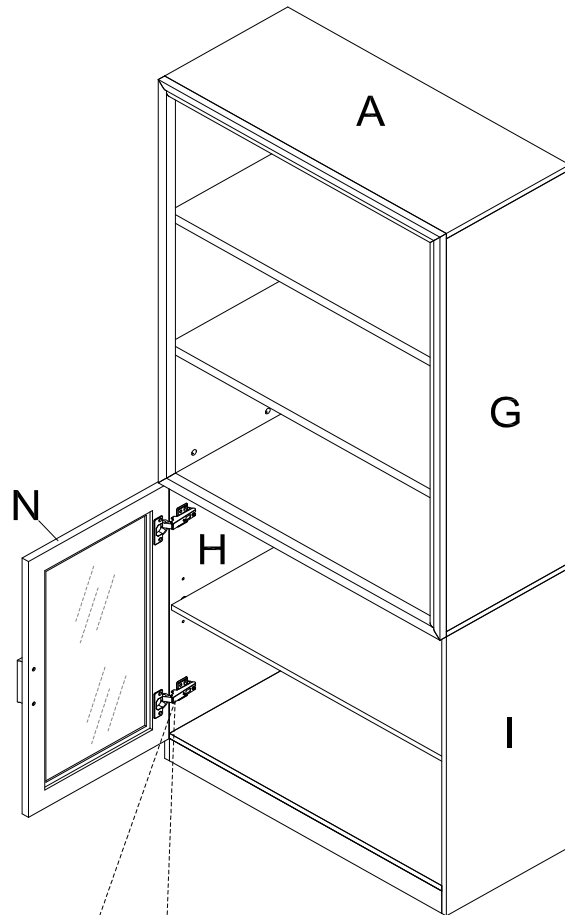

12

8		x 8
15		x 1



# Assembly | Asambllea | Assemblage

13

8		x 8
15		x 1

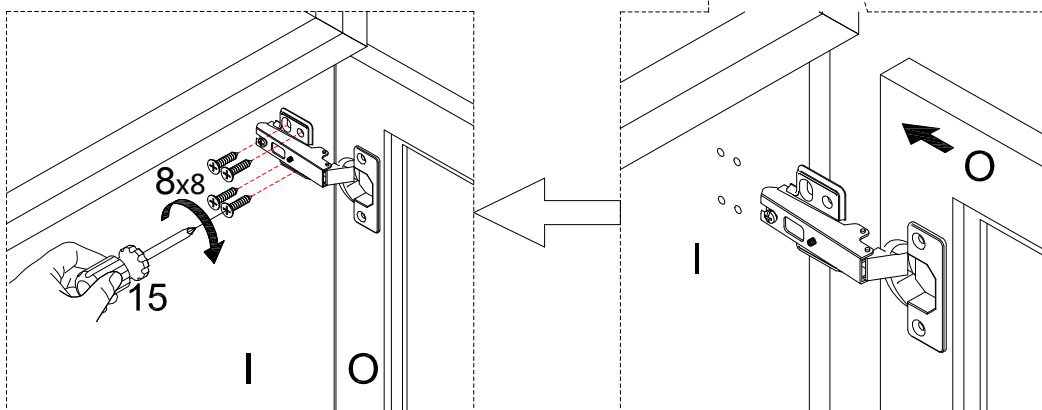
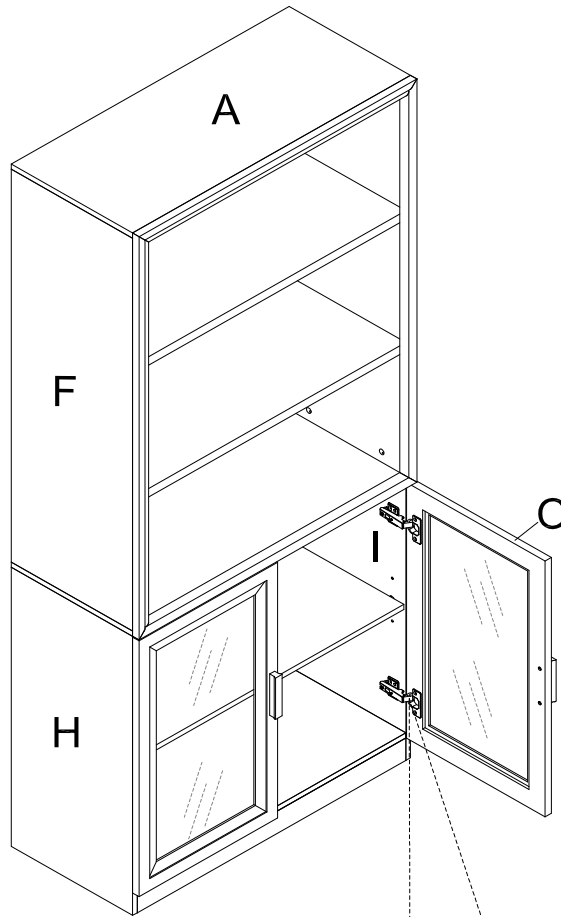

# Assembly | Asambllea | Assemblage

## 14

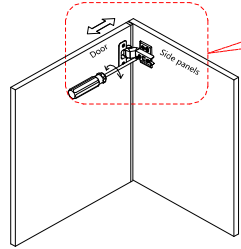

Hinge Adjustment  
Ajuste de la bisagra  
Réglage de la charnière

Left or Right  
Izquierda o derecha  
Gauche ou droite

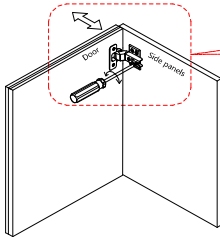
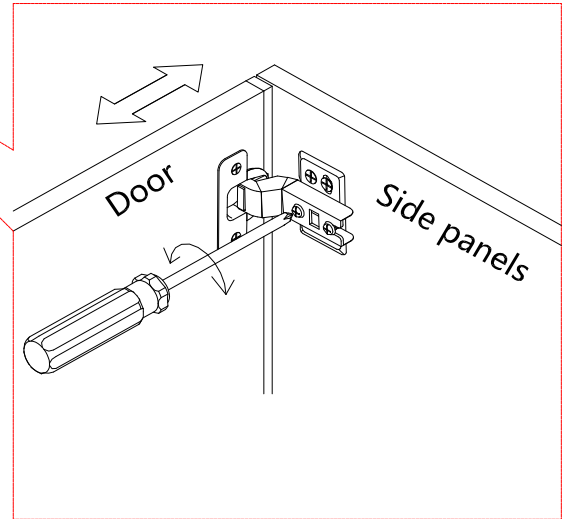

Hinge Adjustment  
Ajuste de la bisagra  
Réglage de la charnière

Forward or Backward  
Hacia adelante o hacia atrás  
Vers l'avant ou vers l'arrière

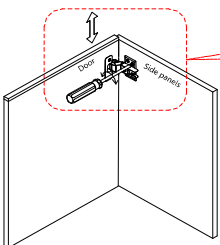
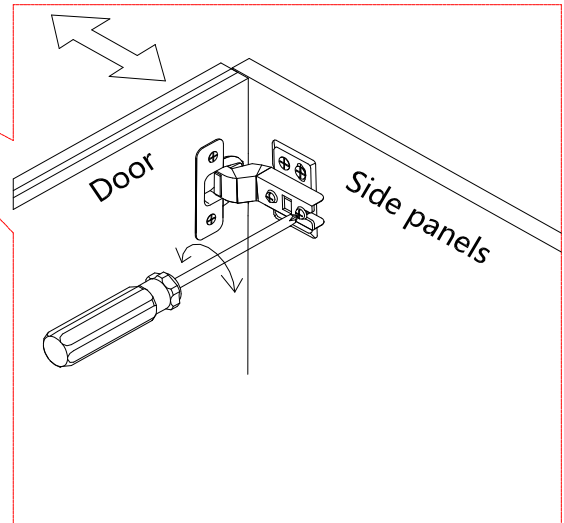

Hinge Adjustment  
Ajuste de la bisagra  
Réglage de la charnière

Up or Down  
Arriba o abajo  
Haut ou bas

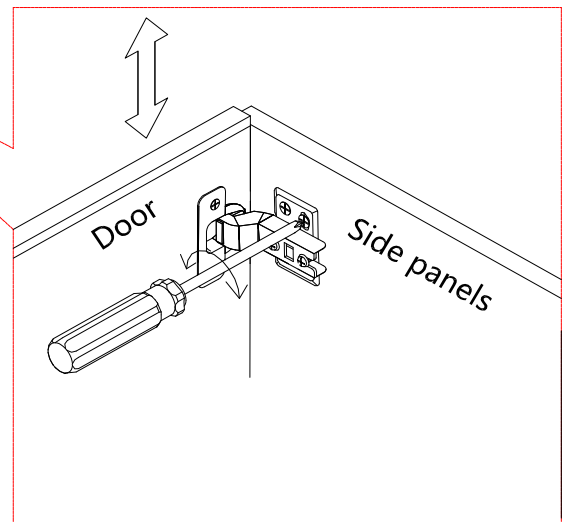

# Assembly | Asambla | Assemblage

## 15

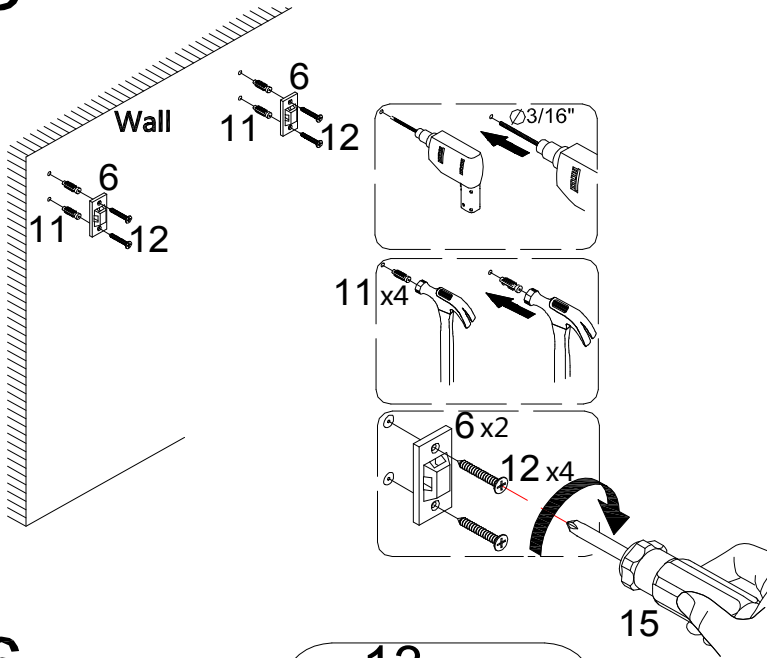

6		x 2
11		x 4
12		x 4
15		x 1

Anti-tipping hardware must be used for this product to avoid tipping and injury.

Se debe usar hardware antivuelco para este producto para evitar que se vuelque y se lesione.

Une quincaillerie anti-basculement doit être utilisée pour ce produit afin d'éviter tout basculement et blessure.

## 16

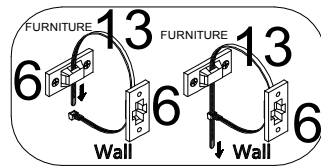

13		x 2
----	--	-----

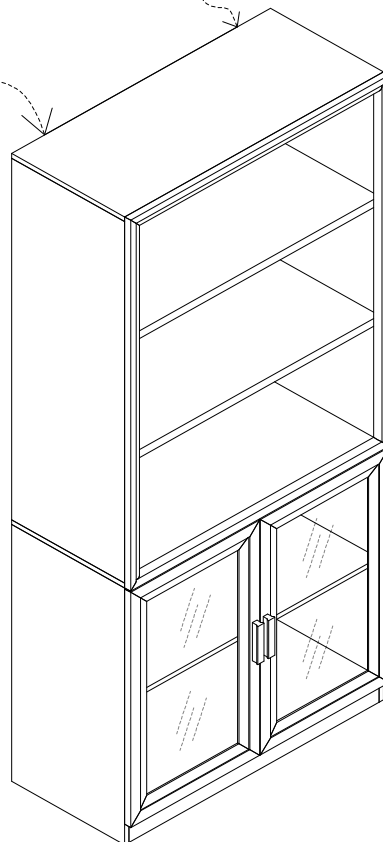

# Assembly | Asamblea | Assemblage

## May We Help You?

800.633.5096 /972-869-0111

Please have this information ready when you call:

- Item Number
- PO #
- Purchaser Name
- Place of Purchase
- Purchase Date
- Date Product Arrived

Immediately examine this product carefully. Any request for missing or damaged part replacement must be received within 90 days of your receipt of the product. Requests for replacement parts, if available, will be honored within this time frame. Parts will not be available for items arriving fully assembled. We do not recommend modifying products and we are not responsible for any damages due to product modifications. If damages or missing parts are not reported within 90 days of receiving the product, we are under no obligation to provide parts or replacement merchandise. For product issues, please contact customer service at 800-633-5096 (toll-free) Mon-Fri 8:30am – 5pm CST. Please ask for a customer service representative for issues involving damages or replacement parts. Please ask for a technical assistance representative for any issues related to product assembly/construction. Regarding product returns, please contact the retailer from whom you purchased the product.

Please note, for items purchased in a retail store, you will need to contact the retailer for all part needs.

Products purchased at garage sales or discount stores are sold as-is and are not covered by the above warranty

## ¿Podemos ayudarle?

800.633.5096 /972-869-0111

Tenga a mano esta información cuando llame:

- Número de artículo
- PO #
- Nombre del comprador
- Lugar de compra
- Fecha de compra
- Fecha en que llegó el producto

Inmediatamente examine este producto con cuidado. Cualquier solicitud de reemplazo de piezas faltantes o dañadas debe recibirse dentro de los 90 días posteriores a la recepción del producto. Las solicitudes de repuestos, si están disponibles, serán atendidas dentro de este marco de tiempo. Las piezas no estarán disponibles para los artículos que lleguen completamente ensamblados. No recomendamos modificar los productos y no nos hacemos responsables de los daños debidos a las modificaciones del producto. Si no se informan daños o piezas faltantes dentro de los 90 días de haber recibido el producto, no estamos obligados a proporcionar piezas o productos de reemplazo. Para problemas con el producto, comuníquese con el servicio al cliente al 800-633-5096 (sin cargo) de lunes a viernes, de 8:30 a. M. A 5 p.m. CST. Solicite a un representante de servicio al cliente si tiene problemas con daños o piezas de repuesto. Solicite un representante de asistencia técnica para cualquier problema relacionado con el montaje / construcción del producto. Con respecto a las devoluciones de productos, comuníquese con el vendedor al que le compró el producto.

Tenga en cuenta que, para los artículos comprados en una tienda minorista, deberá comunicarse con el minorista para todas las necesidades de piezas.

Los productos comprados en las ventas de garaje o tiendas de descuento se venden tal como están y no están cubiertos por la garantía anterior.

## Pouvons-nous vous aider?

800.633.5096 /972-869-0111

Veillez avoir cette information à portée de main lorsque vous appelez:

- Numéro d'article
- PO #
- Nom de l'acheteur
- Lieu d'achat
- Date d'achat
- Date d'arrivée du produit

Immédiatement examiner ce produit soigneusement. Toute demande de remplacement de pièce manquante ou endommagée doit être reçue dans les 90 jours suivant la réception de votre produit. Les demandes de pièces de rechange, si elles sont disponibles, seront honorées dans ce délai. Les pièces ne seront pas disponibles pour les articles arrivant complètement assemblés. Nous ne recommandons pas de modifier les produits et nous ne sommes pas responsables des dommages causés par des modifications du produit. Si les dommages ou les pièces manquantes ne sont pas signalés dans les 90 jours suivant la réception du produit, nous ne sommes pas tenus de fournir des pièces ou des produits de remplacement. En cas de problème avec le produit, veuillez contacter le service clientèle le 800-633-5096 (sans frais) du lundi au vendredi de 8h30 à 17h, heure de Paris. S'il vous plaît demander à un représentant du service clientèle pour les problèmes impliquant des dommages ou des pièces de rechange. Veuillez demander à un représentant de l'assistance technique de résoudre tout problème lié à l'assemblage / la construction du produit. En ce qui concerne les retours de produits, veuillez contacter le détaillant chez qui vous avez acheté le produit.

Veillez noter que pour les articles achetés dans un magasin de détail, vous devez contacter le détaillant pour tous les besoins en pièces.

Les produits achetés dans les vide-greniers ou les magasins à prix réduits sont vendus tels quels et ne sont pas couverts par la garantie ci-dessus.