

2 in 1 Dual Shower Head



High Pressure Rain Shower Head with Handheld Combo

Model: SRSRSH1116BN

SRSRSH1116MB

After Sale Service

If replacement part is required, send us an email After-Sales-Service-Desk@outlook.com with part number, the description of your claim and images requested.

Read all instructions prior to installation.

Parts List

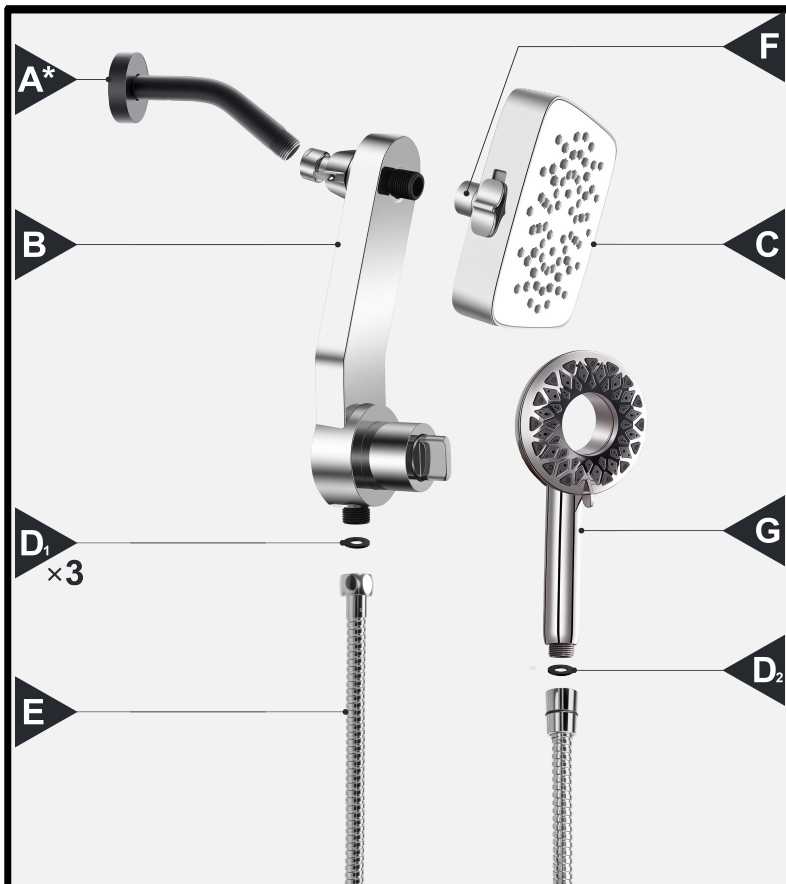

NO.	Part name	Qty
A	Shower Arm (not included)	1
B	Shower Column-Bracket Arm	1
C	Shower head	1
D	Washer (x3) (1 pre-installed)	3
E	70 inch Hose	1
F	Shower Ball	1
G	Hand shower	1
H	Accessories Kit	1

Installation steps



1. Remove Old Showerhead from Shower Arm (A*).
2. Attach Bracket arm (B) to Shower Arm (A*).



1. Thread Showerball (F) to Bracket Arm (B).
2. Tighten Showerball (F) with a wrench.



1. Attach Washer (D1) and Hose (E) to Bracket Arm (B).



1. Attach Washer (D2) and Hose (E) to Hand Shower (G).



1. Dock Hand Shower (H) to Bracket Arm (C).



1. Turn diverter knob of Bracket Arm (C) to desired shower mode.