

# ASSEMBLY INSTRUCTION

## FARMHOUSE TABLE

### IMPORTANT NOTE :

BEFORE YOU BEGIN, PLEASE READ AND FOLLOW THE ASSEMBLY INSTRUCTIONS CAREFULLY.

- IDENTIFY AND SEPARATE ALL PARTS BEFORE DISCARDING PACKAGING.
- PLACE WOODEN PARTS ON A CLEAN SOFT SURFACE TO AVOID SCRATCHING THE PARTS.
- DO NOT USE POWER TOOL FOR ASSEMBLY.
- AS WITH ALL FURNITURE , OCCASIONALLY CHECK TO INSURE HARDWARE IS TIGHT.

### PARTS & HARDWARE LIST

NO	DESCRIPTION	QTY	
A	TABLE TOP	1 PC	BOX A
B	EXT. LEAF	1 PC	BOX B
C	BASE	1 PC	BOX C
D	EMPIRE LEG	4 PCS	BOX B
E	HEX NUT	12 PCS	BOX A
F	SPRING WASHER	12 PCS	
G	FLAT WASHER	12 PCS	
H	WRENCH	1 PC	
I	AJUSTABLE	4 PCS	



FULLY SET UP

### STEP 1

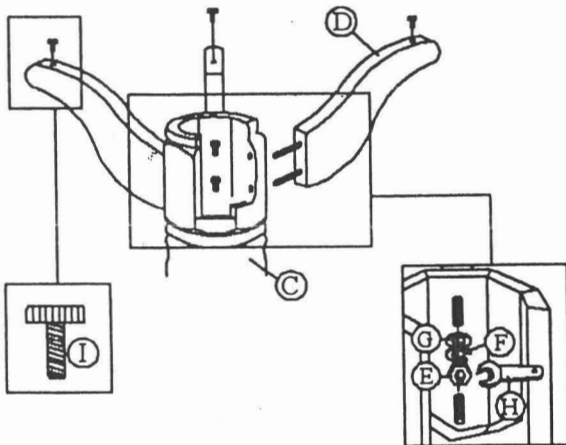

### STEP 2

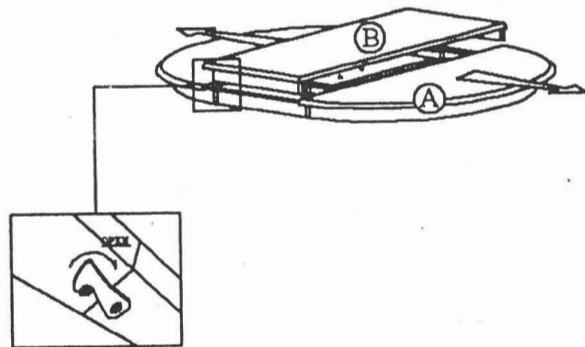

### STEP 3

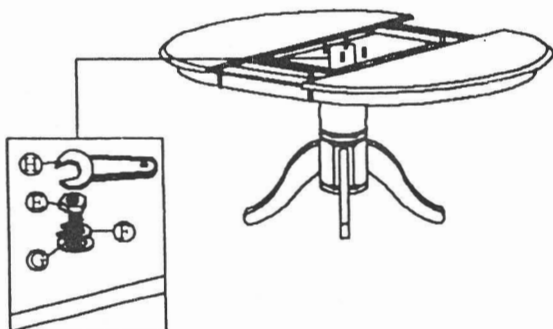



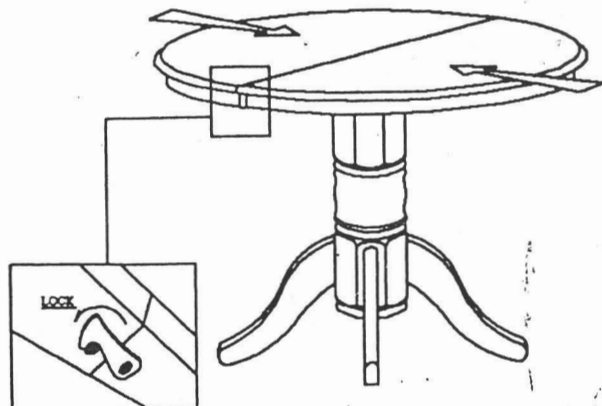

### STEP 4



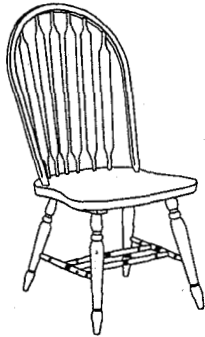

MADE IN MALAYSIA

Model : Arrowback Windsor Chair

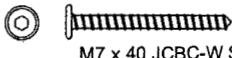
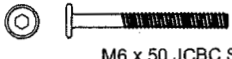

No.	Parts List (1 Chair)	Qty.
P1.	 Seat	1 pc.
P2.	 Leg Frame	2 pcs.
P3.	 Front Stretcher	1 pc.
P4.	 Back Stretcher	1 pc.

No.	Hardware List (1 Chair)	Qty.
H1.	 M4 Allen Key	1 pc.
H2.	 M7 x 40 JCBC-W Screw	6 pcs.
H3.	 M6 x 50 JCBC Screw	2 pcs.
H4.	 Barrel Nut	2 pcs.
H5.	 Wood Button	2 pcs.

**STEP 1**

Assemble Front Stretcher (P3) & Back Stretcher (P4) to the Leg Frame (P2). Fix it by using Barrel Nut (H4) and JCBC Screw (H3) as shown. Then tighten it up with Allen Key (H1).  
 \*Do not fully tighten the screw until final step.

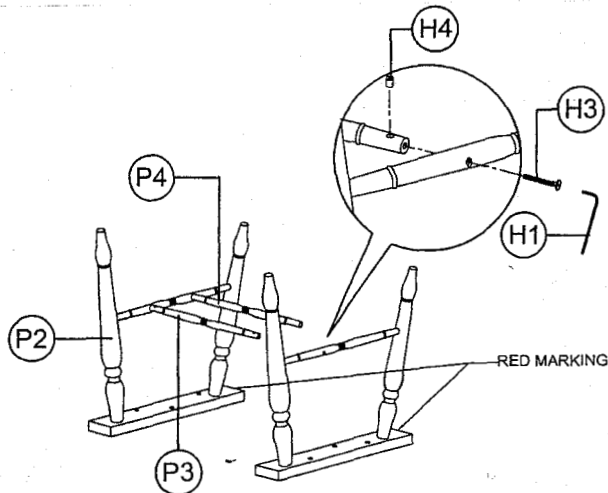

**STEP 2**

Assemble the Leg Frame to the Chair Seat (P1) with JCBC-W (H2). Then tighten it up with Allen Key (H1). **RED MARKING** on the Leg Frame should facing **BACK**

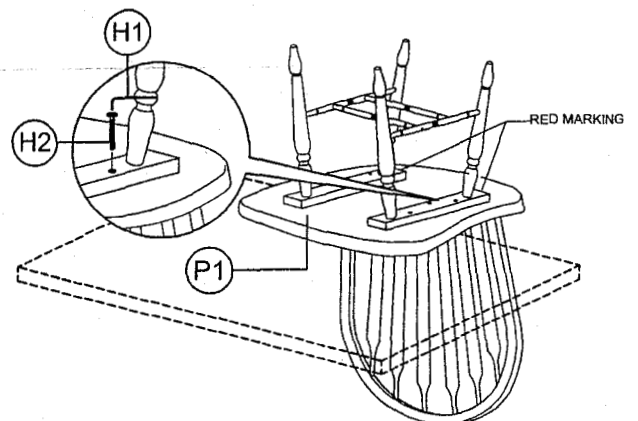

**STEP 3**

Pull the back legs inwards to ensure full connection between Leg Frame (P2) and Front Stretcher (P3).

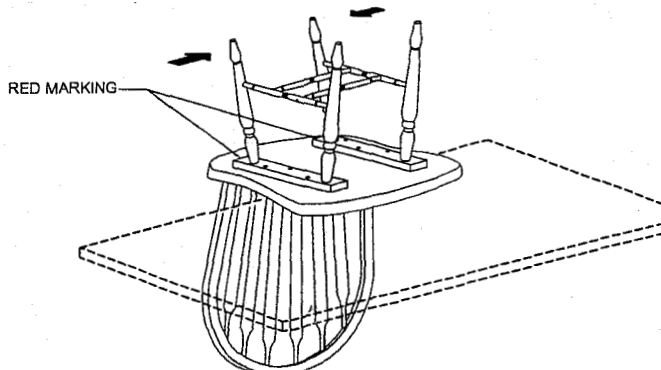



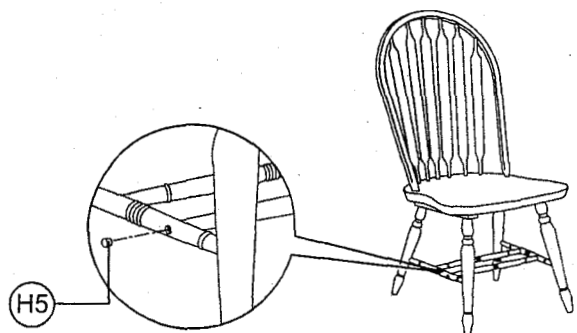

**STEP 4**

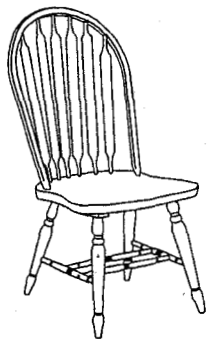

Make sure all legs are level. Once level, tighten up all the screws. Cover the screw holes with Wood Button (H5).



Model : Arrowback Windsor Chair

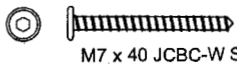
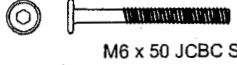

No.	Parts List (1 Chair)	Qty.
P1.	 Seat	1 pc.
P2.	 Leg Frame	2 pcs.
P3.	 Front Stretcher	1 pc.
P4.	 Back Stretcher	1 pc.

No.	Hardware List (1 Chair)	Qty.
H1.	 M4 Allen Key	1 pc.
H2.	 M7 x 40 JCBC-W Screw	6 pcs.
H3.	 M6 x 50 JCBC Screw	2 pcs.
H4.	 Barrel Nut	2 pcs.
H5.	 Wood Button	2 pcs.

**STEP 1**

Assemble Front Stretcher (P3) & Back Stretcher (P4) to the Leg Frame (P2). Fix it by using Barrel Nut (H4) and JCBC Screw (H3) as shown. Then tighten it up with Allen Key (H1).  
 \*Do not fully tighten the screw until final step.

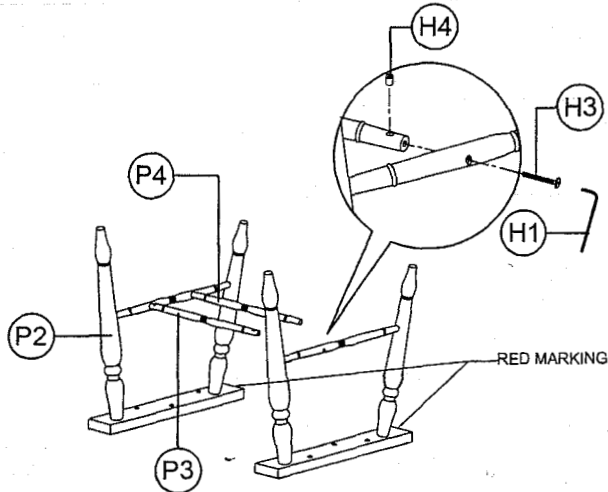

**STEP 2**

Assemble the Leg Frame to the Chair Seat (P1) with JCBC-W (H2). Then tighten it up with Allen Key (H1). **RED MARKING** on the Leg Frame should facing **BACK**

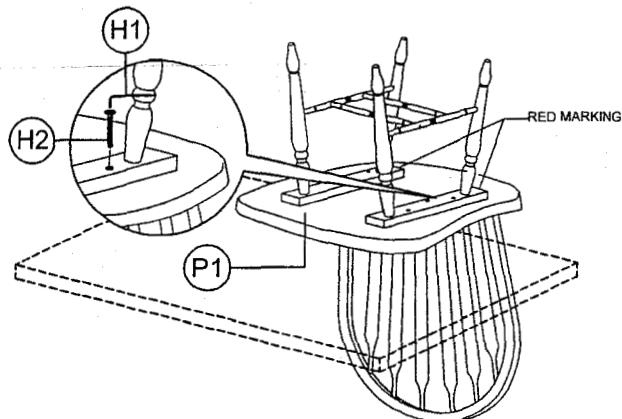

**STEP 3**

Pull the back legs inwards to ensure full connection between Leg Frame (P2) and Front Stretcher (P3).

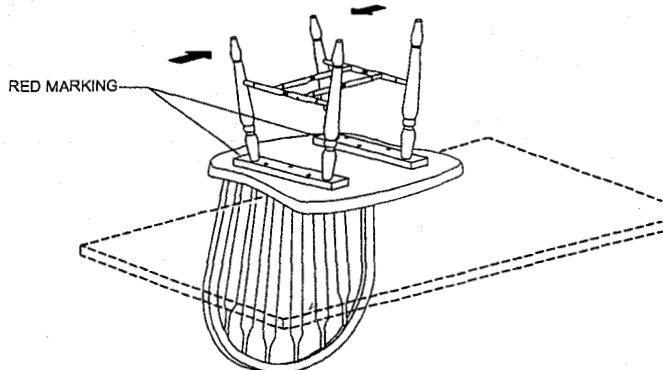



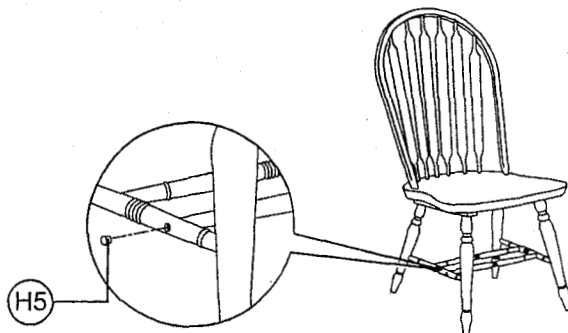

**STEP 4**

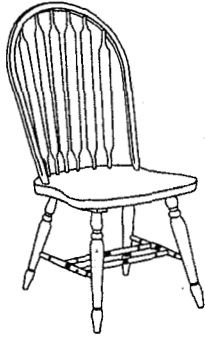

Make sure all legs are level. Once level, tighten up all the screws. Cover the screw holes with Wood Button (H5).



Model : Arrowback Windsor Chair

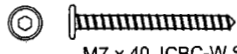
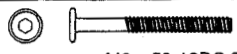

No.	Parts List (1 Chair)	Qty.
P1.	 Seat	1 pc.
P2.	 Leg Frame	2 pcs.
P3.	 Front Stretcher	1 pc.
P4.	 Back Stretcher	1 pc.

No.	Hardware List (1 Chair)	Qty.
H1.	 M4 Allen Key	1 pc.
H2.	 M7 x 40 JCBC-W Screw	6 pcs.
H3.	 M6 x 50 JCBC Screw	2 pcs.
H4.	 Barrel Nut	2 pcs.
H5.	 Wood Button	2 pcs.

**STEP 1**

Assemble Front Stretcher (P3) & Back Stretcher (P4) to the Leg Frame (P2). Fix it by using Barrel Nut (H4) and JCBC Screw (H3) as shown. Then tighten it up with Allen Key (H1).  
 \*Do not fully tighten the screw until final step.

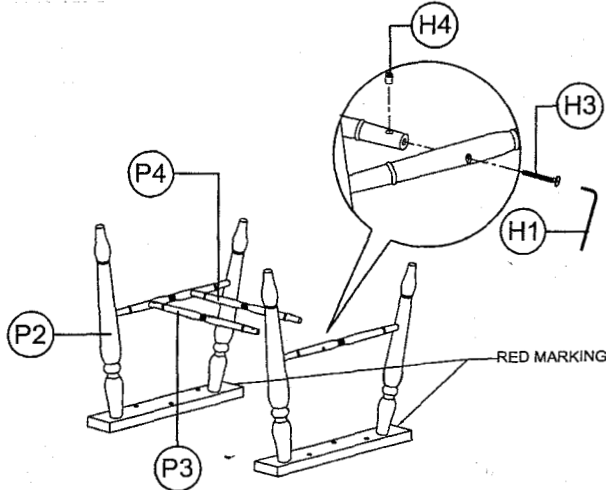

**STEP 2**

Assemble the Leg Frame to the Chair Seat (P1) with JCBC-W (H2). Then tighten it up with Allen Key (H1). **RED MARKING** on the Leg Frame should facing **BACK**

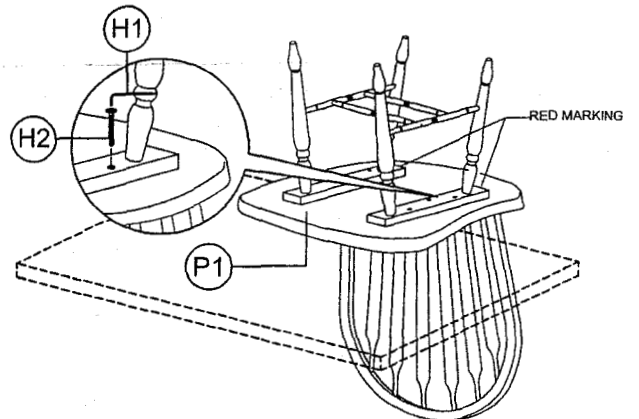

**STEP 3**

Pull the back legs inwards to ensure full connection between Leg Frame (P2) and Front Stretcher (P3).

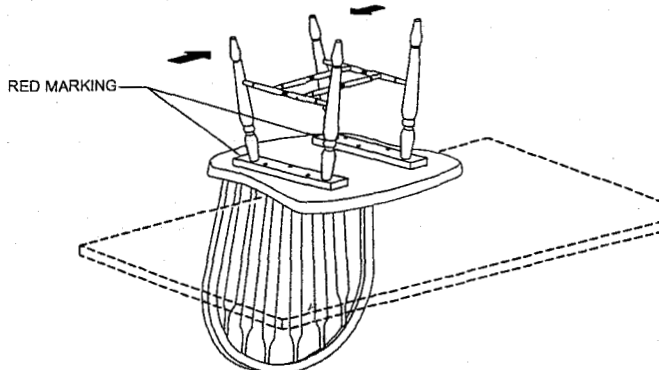

**STEP 4**

Make sure all legs are level. Once level, tighten up all the screws. Cover the screw holes with Wood Button (H5).

