

THANKS FOR WATCHING

Your feedback is invaluable to us and we would love to hear about your experience. Please take the time to leave us a review.

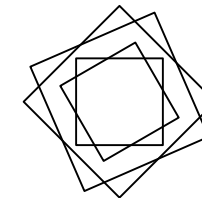

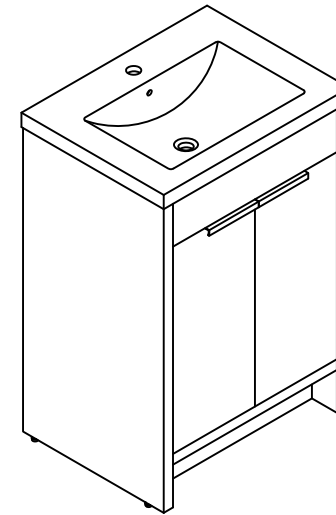









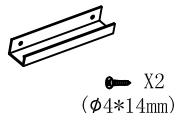

Thank you for shopping with us!

We encourage you to take a few minutes to go through this booklet. It contains important information on installation and care tips to keep your furniture looking as good as new.

Item NO.:BV B02424/30/36

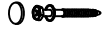
Hardware

NO.	Draw	QTY	NO.	Draw	QTY
A	 (Ø4*14mm)	48	I		3
B		28	K	 X2 (Ø4*14mm)	2
C		28	L		4
D		4	E		2
F		2	N		4
G		2	O		4
H		2	P		2

Recommended tools

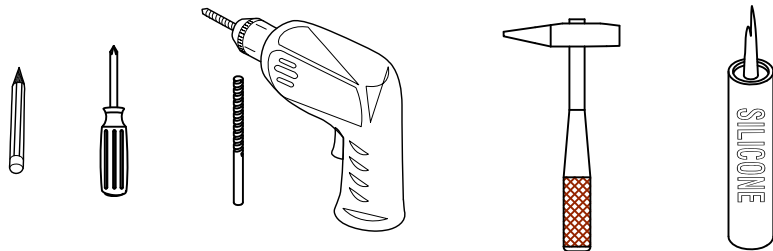

Dimensions

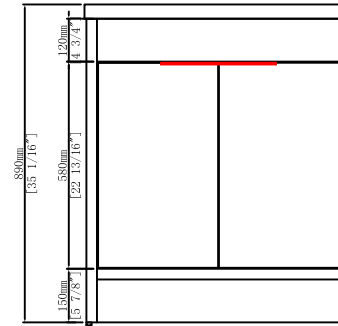

Front View

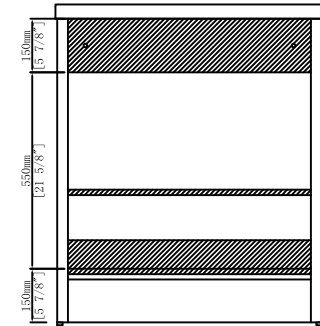

Back View

CARE CLEANING AND MAINTENANCE

1. Dust regularly with a soft , dry cloth.
2. Avoid the use of all chemicals household cleaners, abrasives, or cleaners that contain lemon, vinegar, or other acids that may damage the finish.
3. Excessive exposure to sunlight and extreme changes in temperature and moisture can damage wood furniture.
4. The sink top is resilient, but care needs to be taken to preserve its appearance.
5. Do not place hot appliances, such as curling irons and hot hair dryers directly on the countertop. Wipe spills immediately.

Dimensions

NO SINK

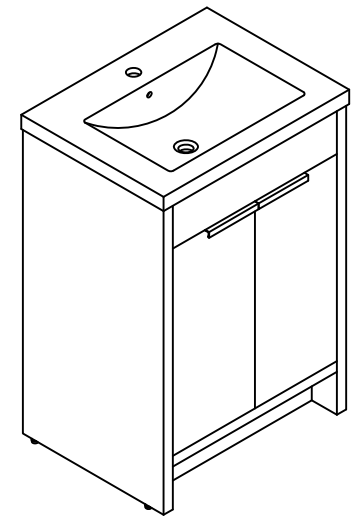
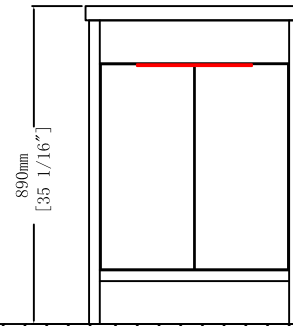

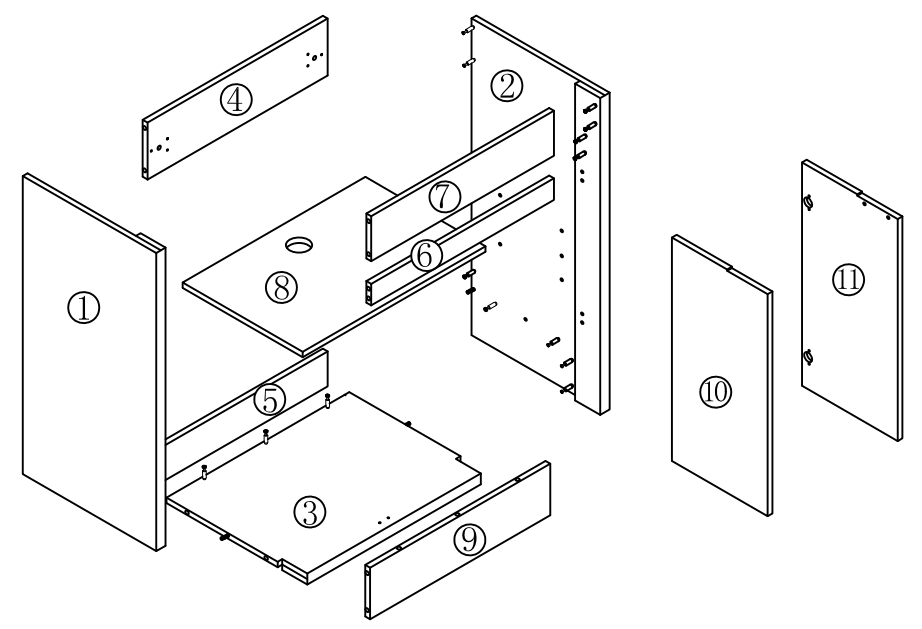

Floor

Parts

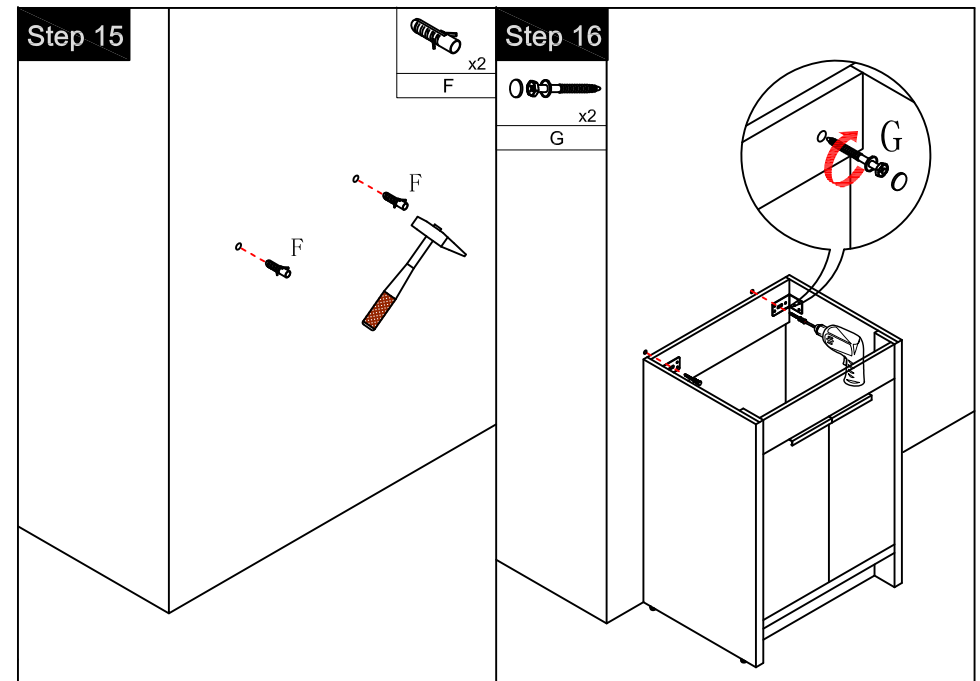
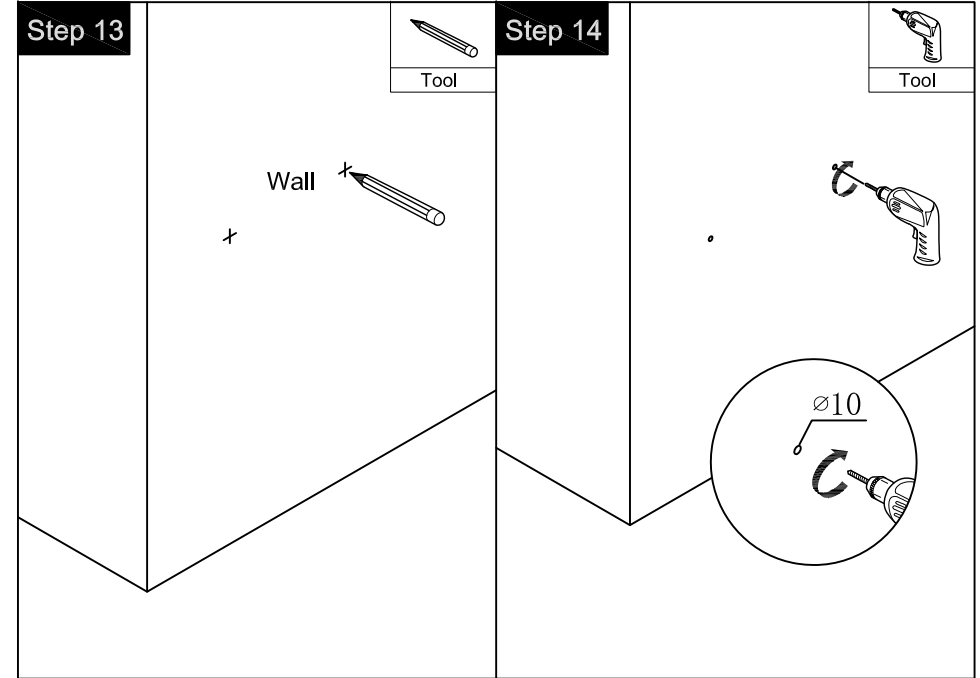
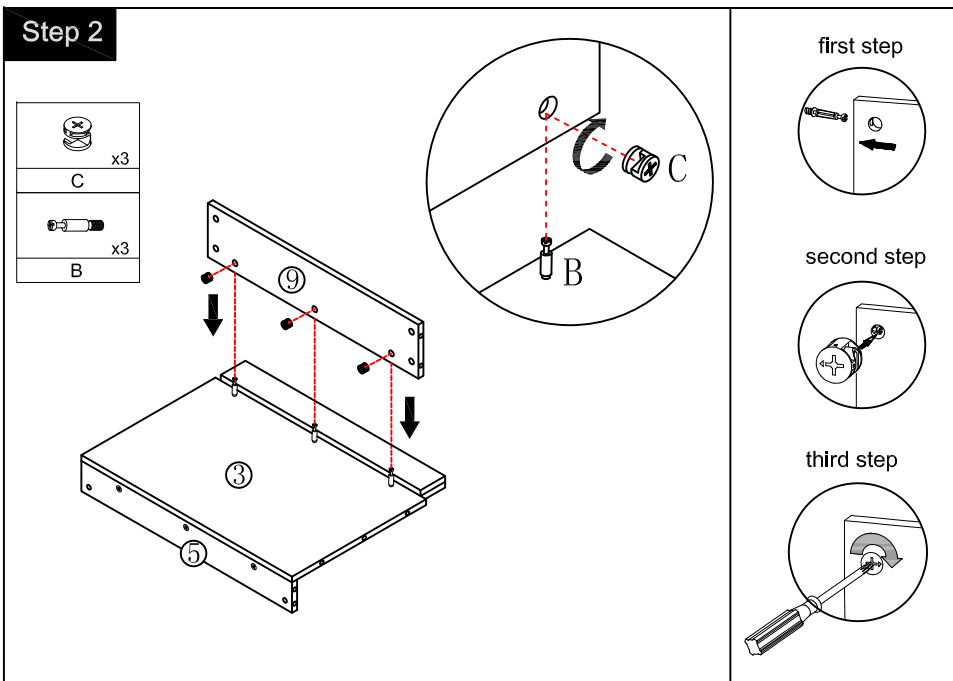
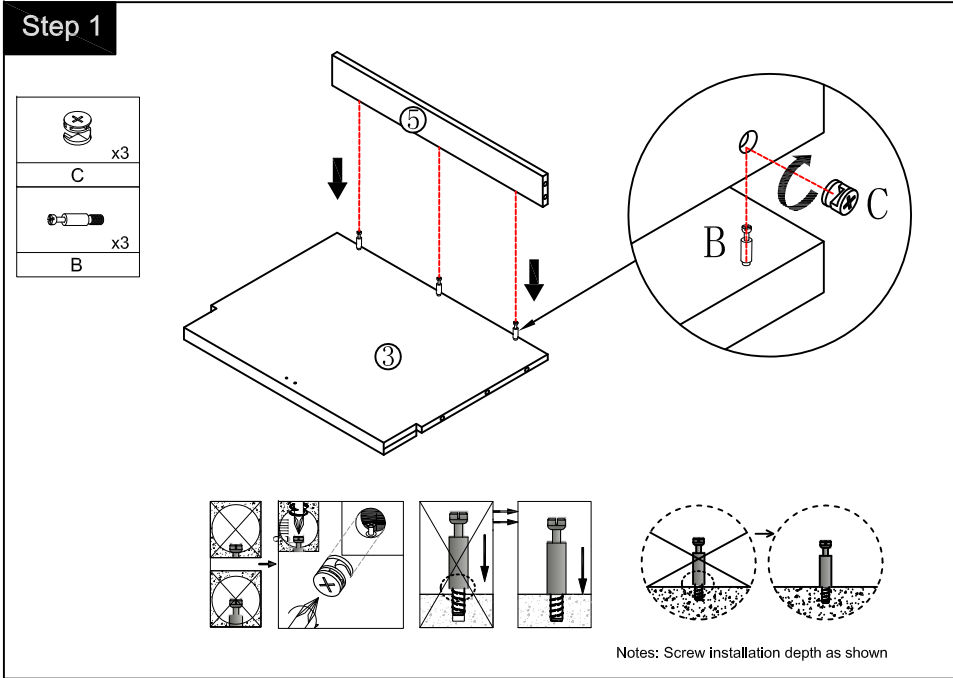



Step 11

	x4
L (Ø4 x 14mm)	
	x24
A	

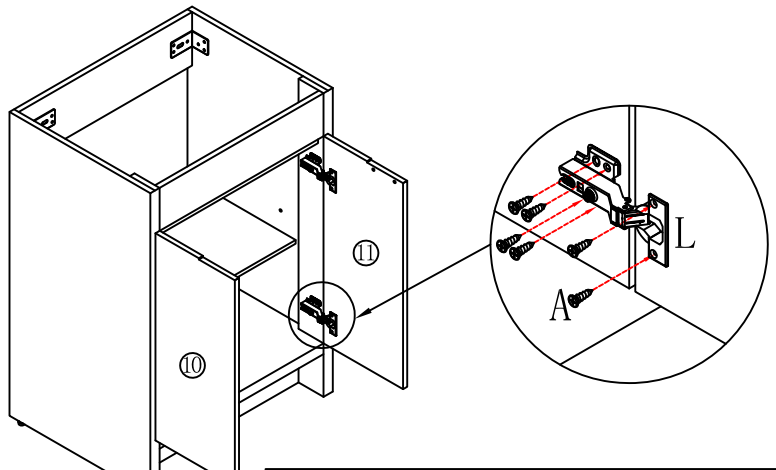

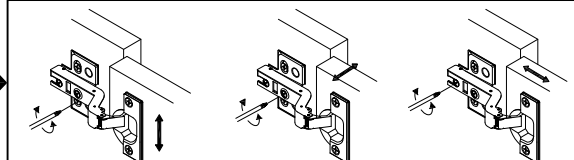

You can adjust the doors by tightening or loosening the screws on the hinge.





Step 12

Congratulations!
Completing the step,
the cabinet base has been assembled

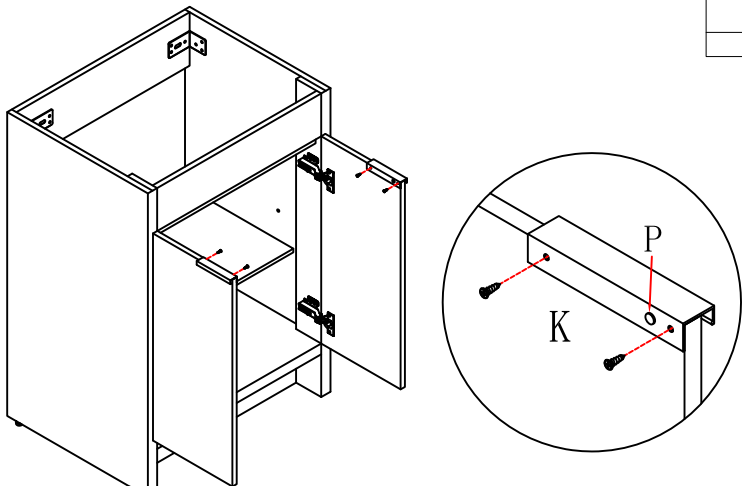
	x2
K	
	x2
P	



Step 3

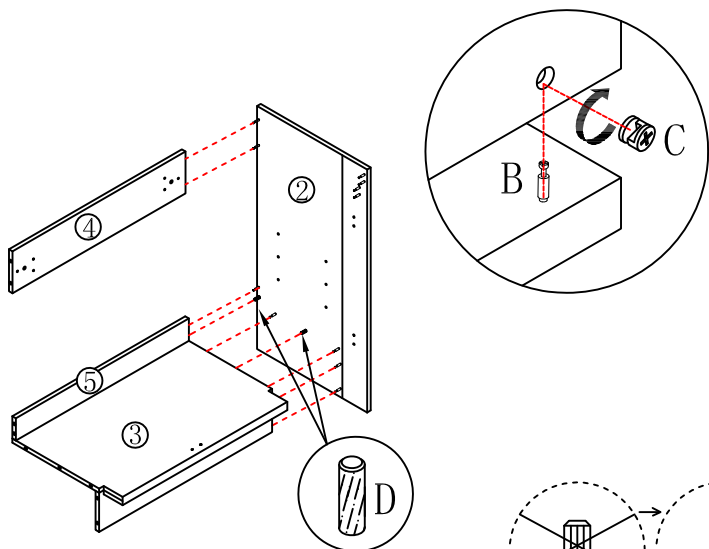

	x7
C	
	x7
B	
	x2
D	

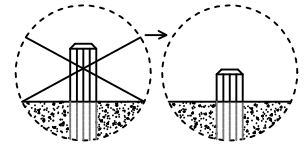

Note: The D parts are used for these two holes



Step 4

	x4
C	
	x4
B	

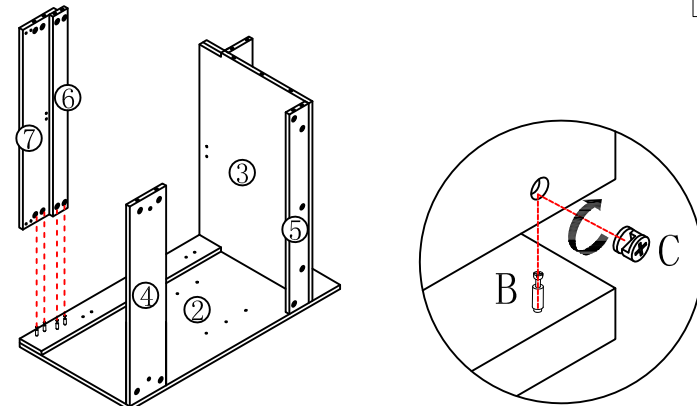

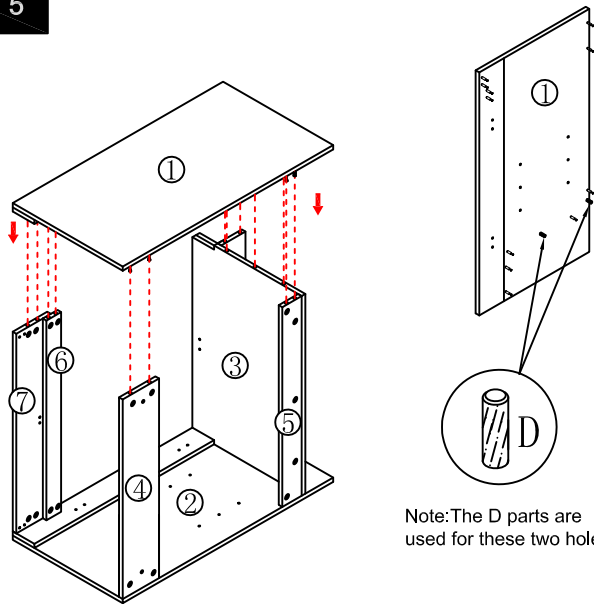

Step 5



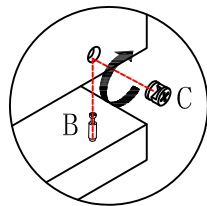

Note: The D parts are used for these two holes

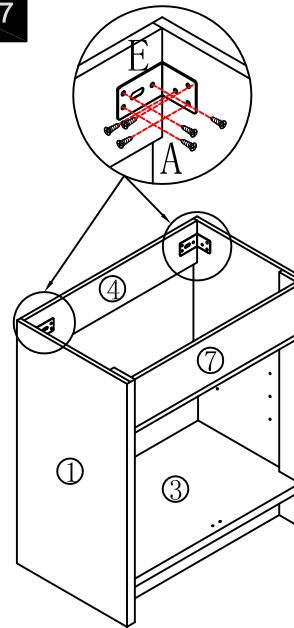

	x11
C	
	x11
B	
	x2
D	

Step 7



	x2
E	
(∅4 x 14mm)	
	x12
A	

Step 8

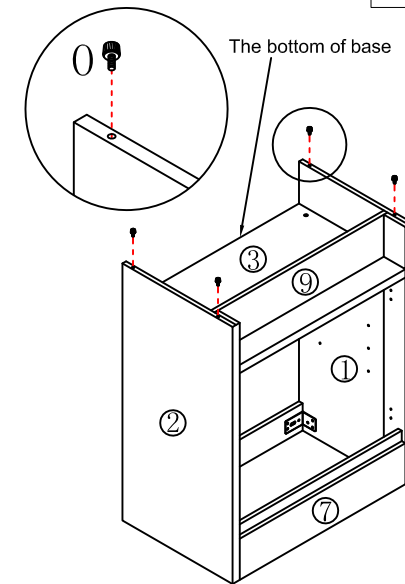



The bottom of base

	x4
O	

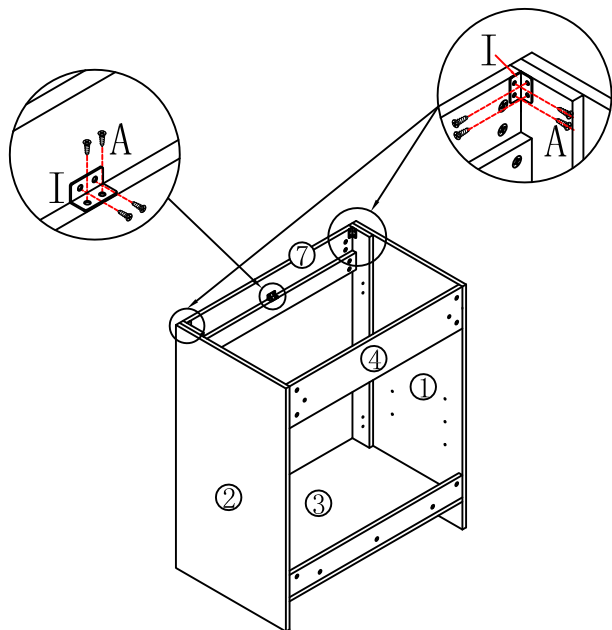
Step 6



	x3
I	
(∅4 x 14mm)	
	x12
A	

Step 9

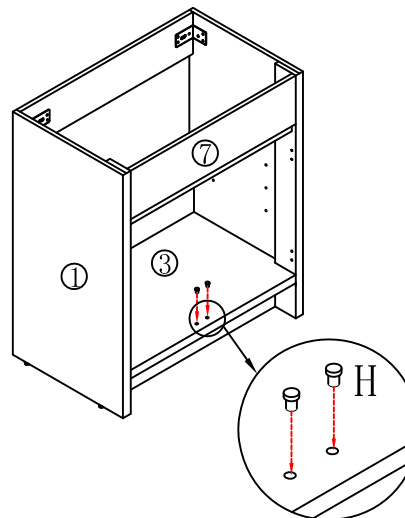

	x2
H	

Step 10

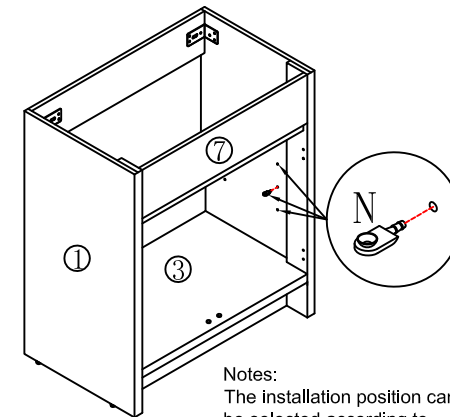

Notes:
The installation position can be selected according to the required height.

	x4
N	