







ASSEMBLY INSTRUCTION





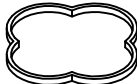

Thank you for purchasing the quality product . be sure to check all packing material carefully for small parts which may have come loose inside the carton during shipment.separate,Identify and count all parts and metal hardware.Compare with all parts list to be sure all parts are present.if any part(s) are missing or damaged,please contact your local furniture dealer. for efficient and speedy service, please indicate the model number and code letter of part(s) needed.

*****Do not fully tighten screws until fully assembled*****

COMPONENT PARTS			
DESCRIPTION	PART NAME		Q'TY (PCS)
①	STOOL POST		4
②	STOOL LEG		16
③	STOOL SEAT		4
④	TABLE TOP		1

COMPONENT PARTS			
DESCRIPTION	PART NAME		Q'TY (PCS)
⑤	TABLE FRAME		1
⑥	TABLE LEG		4
⑦	TABLE FRAME		1

HARDWAES REQUIRED

- A  ALLEN KEY - 1 PC
- B  BOLT $\frac{1}{4}$ "*1/2" - 52 PCS
- C  BOLT $\frac{1}{4}$ "*23/32" - 4 PCS
- D  LOCK WASHER - 16 PCS
- E  FLAT WASHER - 16 PCS
- F  NUT - 16 PCS
- G  OPEN ENDED WRENCH - 1 PC



ATTENTION:

*** Some number parts listed on the instruction sheet may not be in parts bag as they may already be assembled. Carefully check parts and packing materials prior to ordering replacements

How to assemble:

STEP 1:

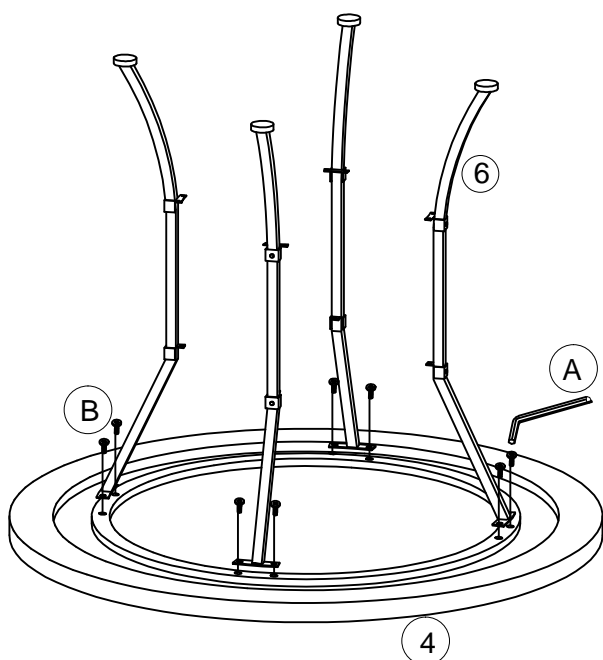

STEP 2:

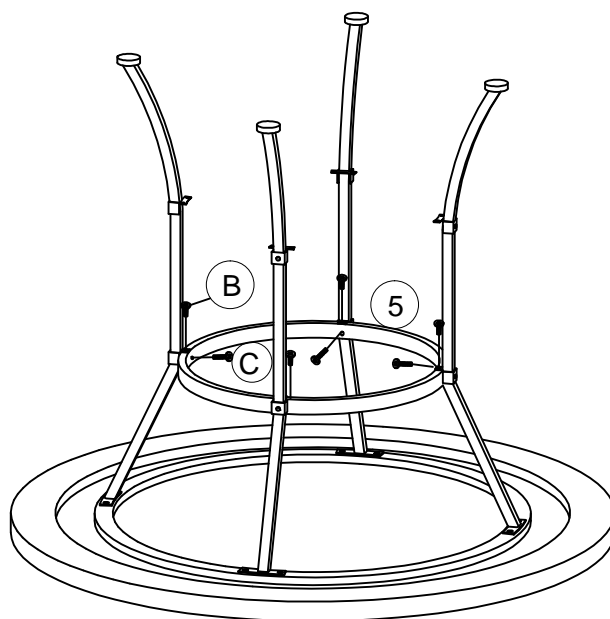

STEP 3:

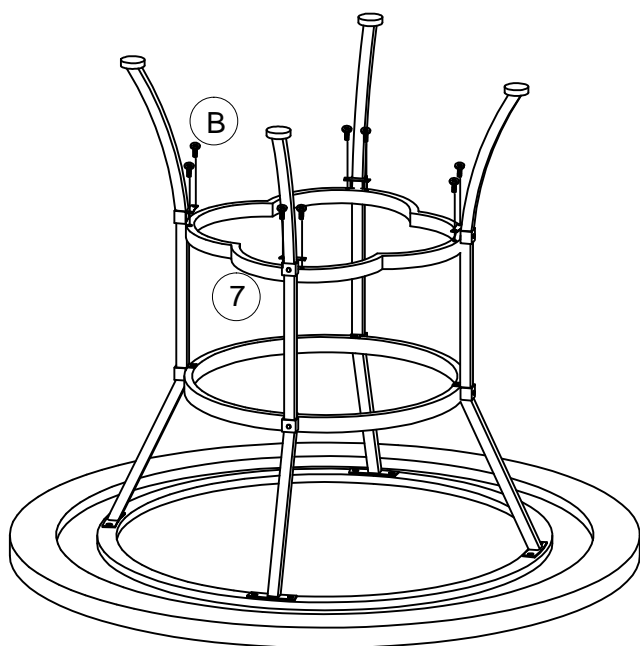

STEP 4:



How to assemble:

STEP 5:

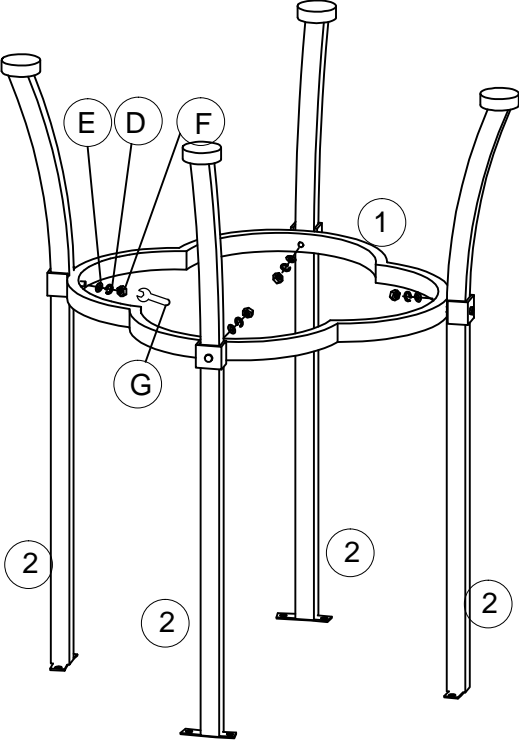

STEP 6:

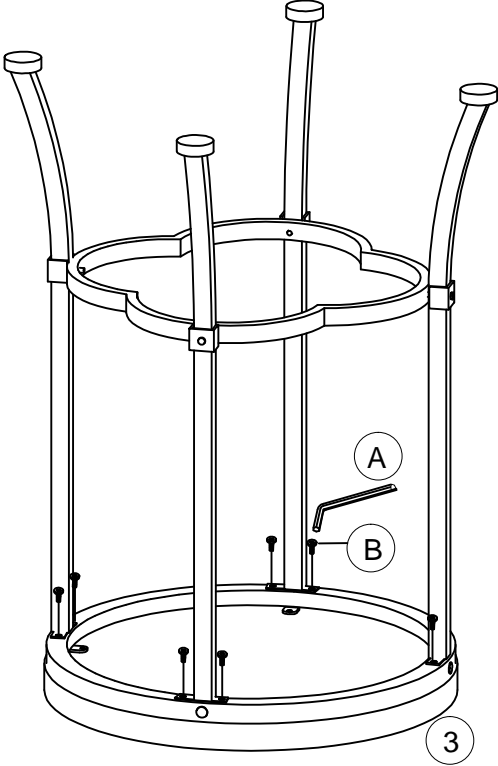

STEP 7:

