

Installation & Assembly

High cabinet wird mit 2 Kartons geliefert. Wir empfehlen, das Set nach Erhalt aller Kartons zusammenzustellen.

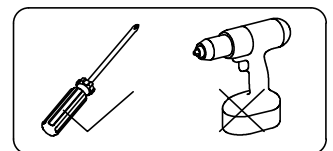
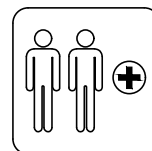
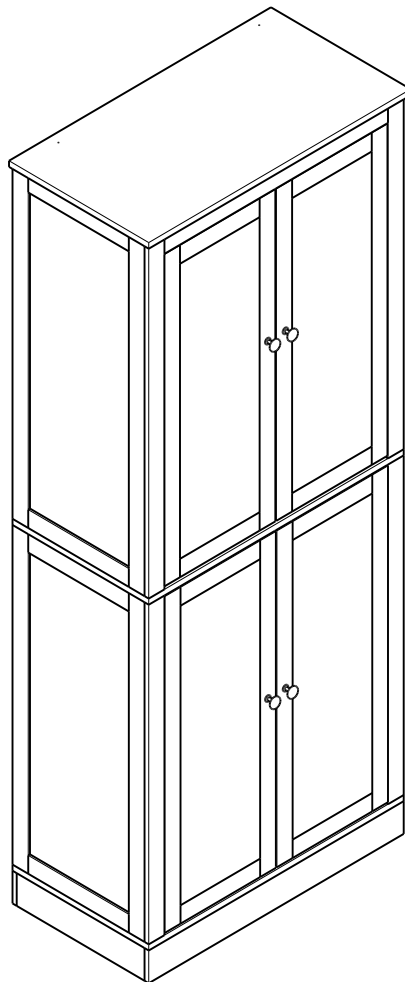

EN_IMPORTANT,RETAINFORFUTUREREERENCE;READCAREFULLY.
FR_IMPORTANT:ALIREATTENTIVEMENTETAACONSERVERPOURCONSULTATION
ULTERIEURE.
ES_IMPORTANTE,LEAYGUARDEPARAFUTURASREFEREBCUAS.
DE_„WICHTIG!SORGEALTIGLESENUNDFURSPATERNACHSCHLAGENAUFBEWAHREN.“
IT_IMPORTANTE!CONSERVAREILPRESENTEMANUALEPERFUTURORIFERIMENTO E
LEGGERLOATTENTAMENTE.

EN

Dear customer,

Thank you for purchasing this product. So that your appliance serves you well, please read all the instructions in this user's manual. If you have any questions, please contact our customer care center.

FR

Cher client,

Nous vous remercions d'avoir acheté ce produit. Afin que vous puissiez profiter pleinement de votre appareil, veuillez lire toutes les instructions de ce manuel d'utilisation. Si vous avez la moindre question, veuillez contacter notre centre d'assistance à la clientèle.

DE

Sehr geehrter Kunde,

Vielen Dank, dass Sie dieses Produkt erworben haben. Damit Ihr Gerät Ihnen gute Dienste leistet, lesen Sie bitte alle Hinweise in diesem Benutzerhandbuch. Wenn Sie Fragen haben, wenden Sie sich bitte an unser Kundendienstzentrum.

ES

Queridos clientes,

Gracias por comprar este producto. Para que su electrodoméstico le sirva mejor, lea todas las instrucciones de este manual del usuario. Si tiene alguna pregunta, comuníquese con nuestro Centro de Atención al Cliente.

IT

Caro Cliente,

Grazie per aver acquistato questo prodotto. Per servirti meglio con questo apparecchio ti prego di leggere tutte le istruzioni in presente manuale utente. In caso di dubbio, si prega di contattare il nostro centro assistenza clienti.

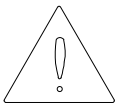

Our product will be delivered to you in 2 packages. The delivery times of these 2 packages may differ, please be patient and thank you for your understanding.

Unser Produkt wird Ihnen in 2 Paketen geliefert. Die Lieferzeiten dieser 2 Pakete können abweichen, bitte haben Sie etwas Geduld und vielen Dank für Ihr Verständnis.

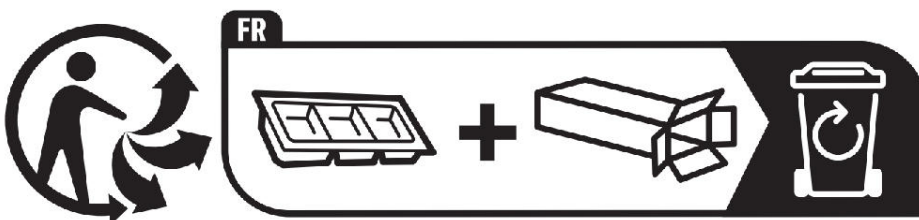

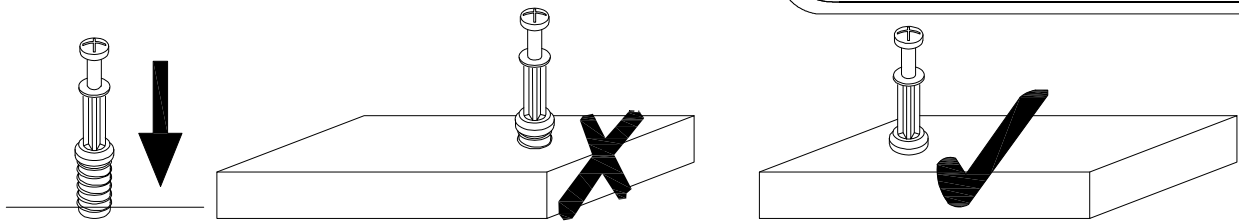

EN_QUICKFIT: Tighten quickfit until shoulder is flush with panel. Do not overtighten or undertighten.

FR_RACCORD RAPIDE: Faites serrer le raccord rapide jusqu'a ce que l'épaulement soit parfaitement encstre dans le panneau. Il ne faut ni trop serrer ni insuffisamment serrer.

ES_QUICKFIT: Apriete quickfit hasta que el hombro se descargue con el panel. NO lo sobreapriete ni lo apriete poco.

DE_QUICKFIT: Ziehen Sie den quickfit fest, bis die Schulter mit der Platte bundig ist.

Bitte nicht zu fest oder zu schwach anziehen.

IT_MONTAGGIO RAPIDO: Stringere il montaggio rapido fino aquando la spalla e a filo con il pannello, non stringere troppo o troppo poco.

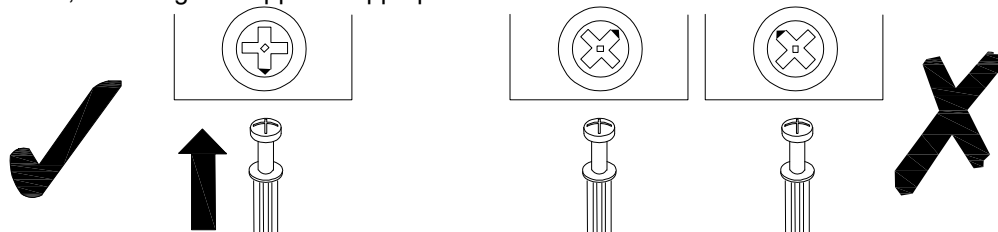

EN_CAM LOCK: When fitting cam lock, ensure starting position is correct before you insert connecting quickfit.

FR_SERRURE BATTEUSE: Avant d'insérer la serrure batteuse, veillez a la bonne orientation avant d'insérer le raccord rapide,

ES_CIERRE DE LA CAMARA: Cuando instale el cierre de la camara, asegurese de que la posicion de inicio es correcta antes de que inserte el quickfit conector,

De_CAM-LOCK: Achten Sie bei der Montage des Cam-locks auf die richtige Ausgangsposition, bevor Sie den Quickfit einsetzen.

IT_BLOCCAGGIO A CAMMA: Quando si monta il bloccaggio a camma, assicurarsi che la posizione iniziale sia corretta prima di inserire il montaggio rapido di collegamento.

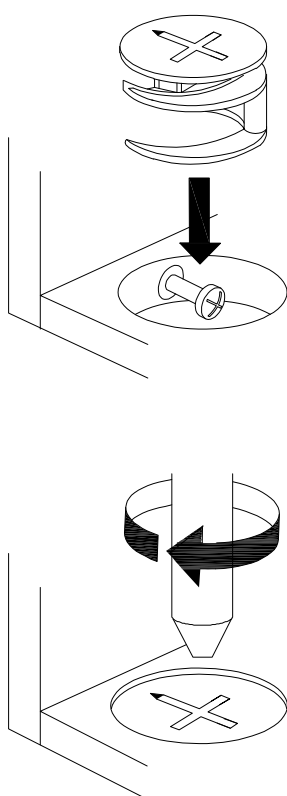

EN_Quickfit head should be in the centre of the cam lock when the two panels are joined.

Cam lock should be inserted before quickfit.

FR_Lorsque les deux panneaux sont assembles, la tete du raccord rapide doit reposer au centre de la serrure batteuse.

Il faut inserer la serrure batteuse avant le raccord rapide.

ES_EL cabezal del quickfit debe estar en el centro del cierre de la camara cuando se unan los dos paneles.

Se debe insertar el cierre de la camara antes que el quickfit.

DE_Der Quickfit-Kopf sollte sich in der Mitte des Cam-locks befinden, wenn die beiden Platten zusammengefügt sind.

Der Cam-lock sollte vor dem Quickfit eingesetzt werden.

IT_La testa del montaggio rapido deve trovarsi al centro del bloccaggio a camma quando i due pannelli sono uniti.

Il Bloccaggio a Camma deve essere inserito prima del montaggio rapido.

EN_Turn cam lock clockwise to tighten.

FR_Faites tourner la serrure batteuse dans le sens des aiguilles d'une montre pour la resserrer.

ES_Gire el cierre de la camara en sentido horario para apretarlo.

DE_Drehen Sie den Cam-Lock im Uhrzeigersinn, um ihn festzuziehen.

IT_Ruotare il bloccaggio a camma in senso orario per stringere.

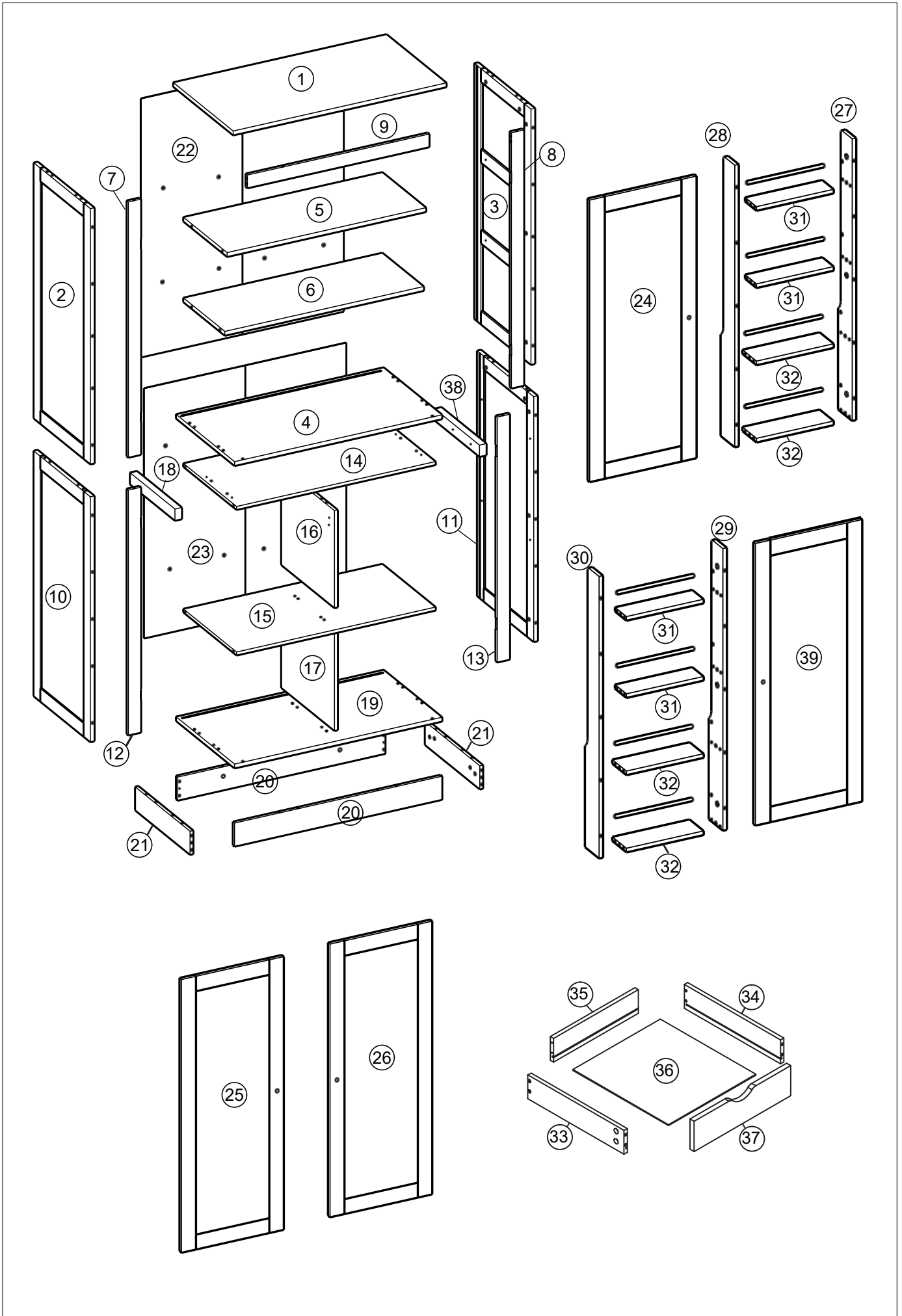

BOX-1/2

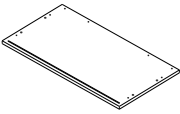
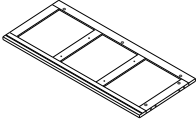
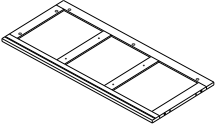
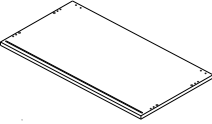
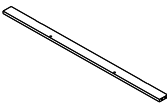
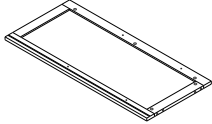
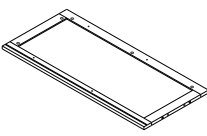
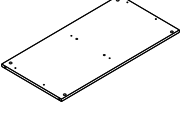
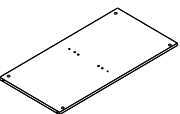
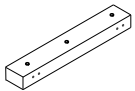
| NO. | PARTS | QTY |
|-----|---|-----|
| ① |  | x1 |
| ② |  | x1 |
| ③ |  | x1 |
| ④ |  | x1 |
| ⑨ |  | x1 |
| ⑩ |  | x1 |
| ⑪ |  | x1 |
| ⑭ |  | x1 |
| ⑮ |  | x1 |
| ⑱ |  | x1 |

BOX-1/2

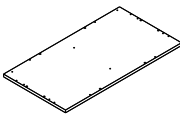
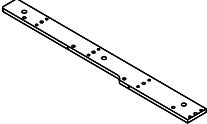
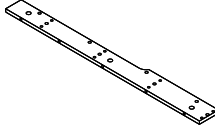
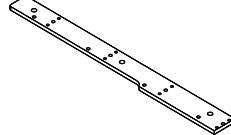
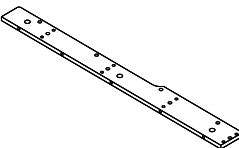
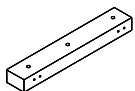
| NO. | PARTS | QTY |
|-----|---|-----|
| ⑲ |  | x1 |
| ⑳ |  | x1 |
| ㉘ |  | x1 |
| ㉙ |  | x1 |
| ㉚ |  | x1 |
| ㉛ |  | x1 |

BOX-2/2

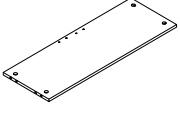
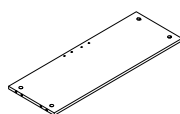
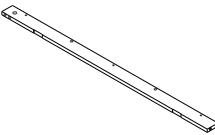
| NO. | PARTS | QTY |
|-----|---|-----|
| ⑤ |  | x1 |
| ⑥ |  | x1 |
| ⑦ |  | x1 |

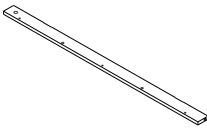
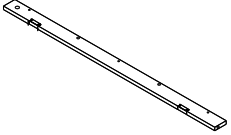
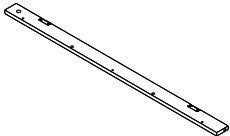
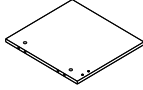
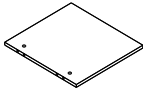
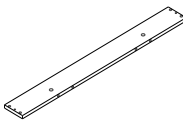
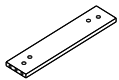
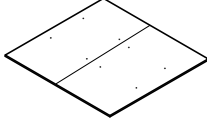
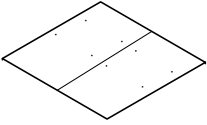
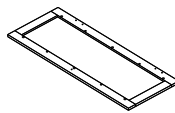

BOX-2/2

| NO. | PARTS | QTY |
|-----|---|-----|
| ⑧ |  | x1 |
| ⑫ |  | x1 |
| ⑬ |  | x1 |
| ⑯ |  | x1 |
| ⑰ |  | x1 |
| ⑳ |  | x2 |
| ㉑ |  | x2 |
| ㉒ |  | x1 |
| ㉓ |  | x1 |
| ㉔ |  | x1 |

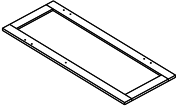
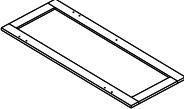
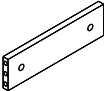
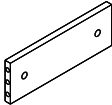
BOX-2/2

| NO. | PARTS | QTY |
|-----|---|-----|
| 25 |  | x1 |
| 26 |  | x1 |
| 31 |  | x4 |
| 32 |  | x4 |

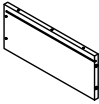
BOX-2/2

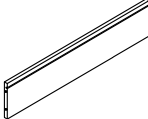
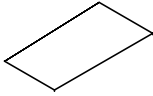
| NO. | PARTS | QTY |
|-----|---|-----|
| 33 |  | x1 |
| 34 |  | x1 |
| 35 |  | x1 |
| 36 |  | x1 |

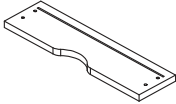
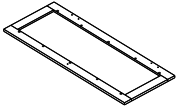

BOX-2/2

| NO. | PARTS | QTY |
|-----|---|-----|
| 37 |  | x1 |
| 39 |  | x1 |

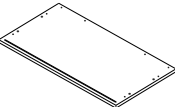
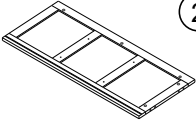
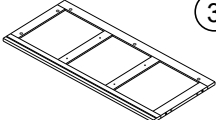
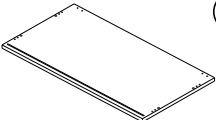
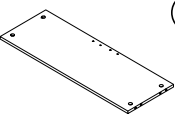
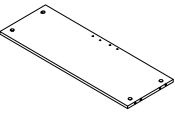
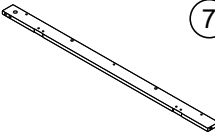
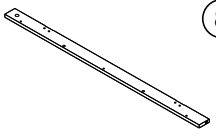
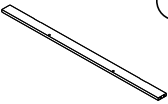
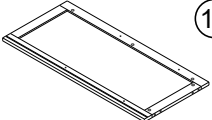
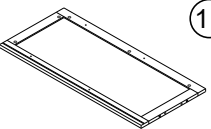
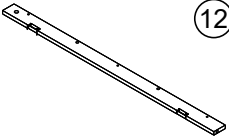
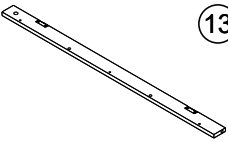
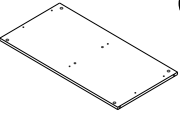
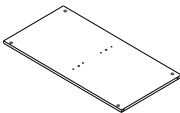
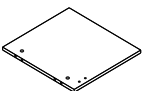
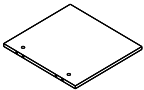
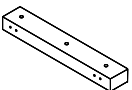
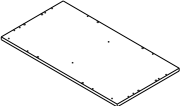
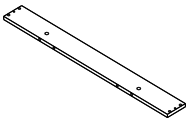
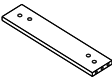
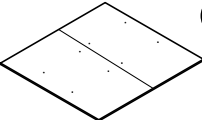
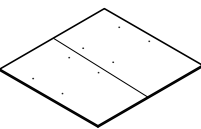
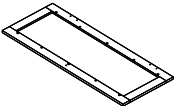



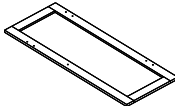
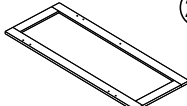
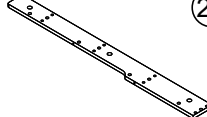
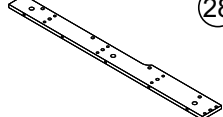
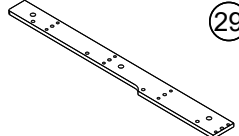
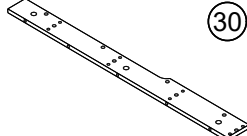
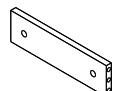
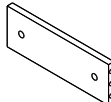
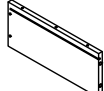

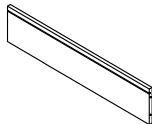
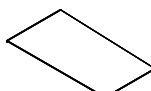
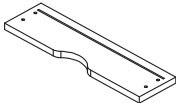
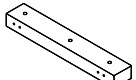
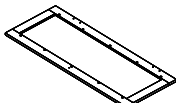



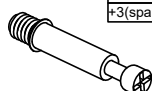

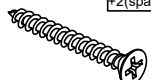

PARTS

| | | | |
|--|--|---|--|
|  ① x1 |  ② x1 |  ③ x1 |  ④ x1 |
|  ⑤ x1 |  ⑥ x1 |  ⑦ x1 |  ⑧ x1 |
|  ⑨ x1 |  ⑩ x1 |  ⑪ x1 |  ⑫ x1 |
|  ⑬ x1 |  ⑭ x1 |  ⑮ x1 |  ⑯ x1 |
|  ⑰ x1 |  ⑱ x1 |  ⑲ x1 |  ⑳ x2 |
|  ㉑ x2 |  ㉒ x1 |  ㉓ x1 |  ㉔ x1 |

PARTS

| | | | |
|---|---|--|---|
|  25 x1 |  26 x1 |  27 x1 |  28 x1 |
|  29 x1 |  30 x1 |  31 x4 |  32 x4 |
|  33 x1 |  34 x1 |  35 x1 |  36 x1 |
|  37 x1 |  38 x1 |  39 x1 | |

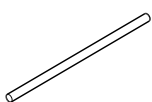
HARDWARE

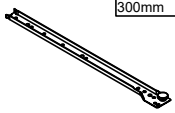
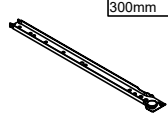
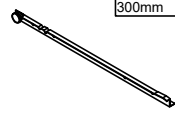
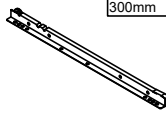
| | | | | | | |
|---|--|---|---|--|---|---|
|  A x90 6x35mm +3(spare) |  B x90 15x10mm +3(spare) |  C x96 6x30mm +3(spare) |  D x24 4x35mm +2(spare) |  E x44 3.5x12mm +3(spare) |  F x8 3x12mm |  G x16 3x14mm +1(spare) |
|  H x2 |  I x4 |  J x6 3x14mm |  K x16 3x14mm +1(spare) |  L x2 |  M x4 4x16mm |  N x8 |
|  O x8 |  P x22 |  Q x4 |  CL x1 300mm |  CR x1 300mm |  DL x1 300mm |  DR x1 300mm |

1

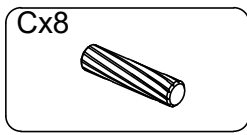
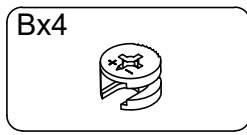
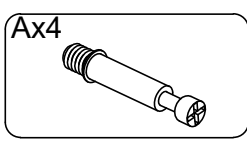
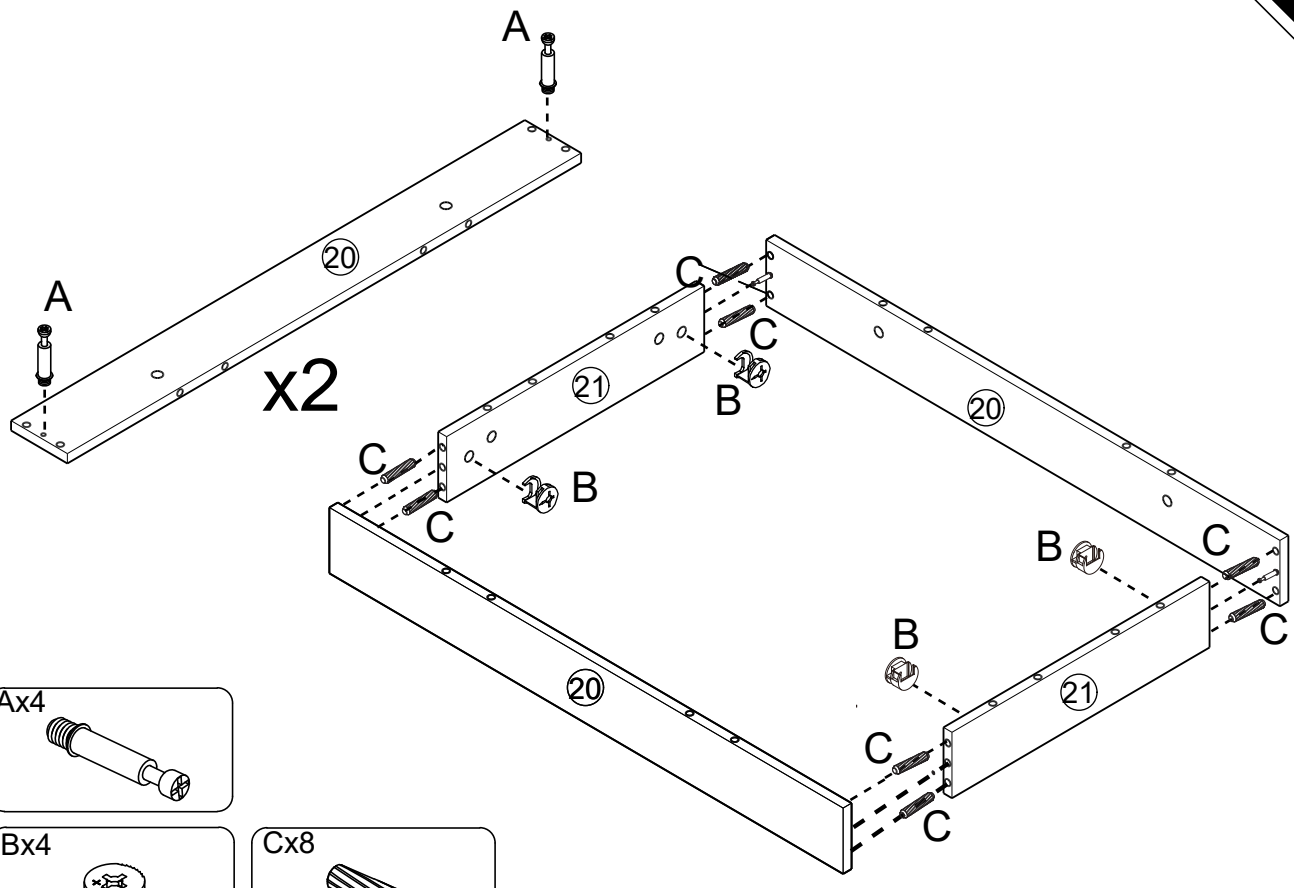

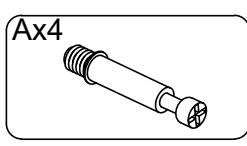
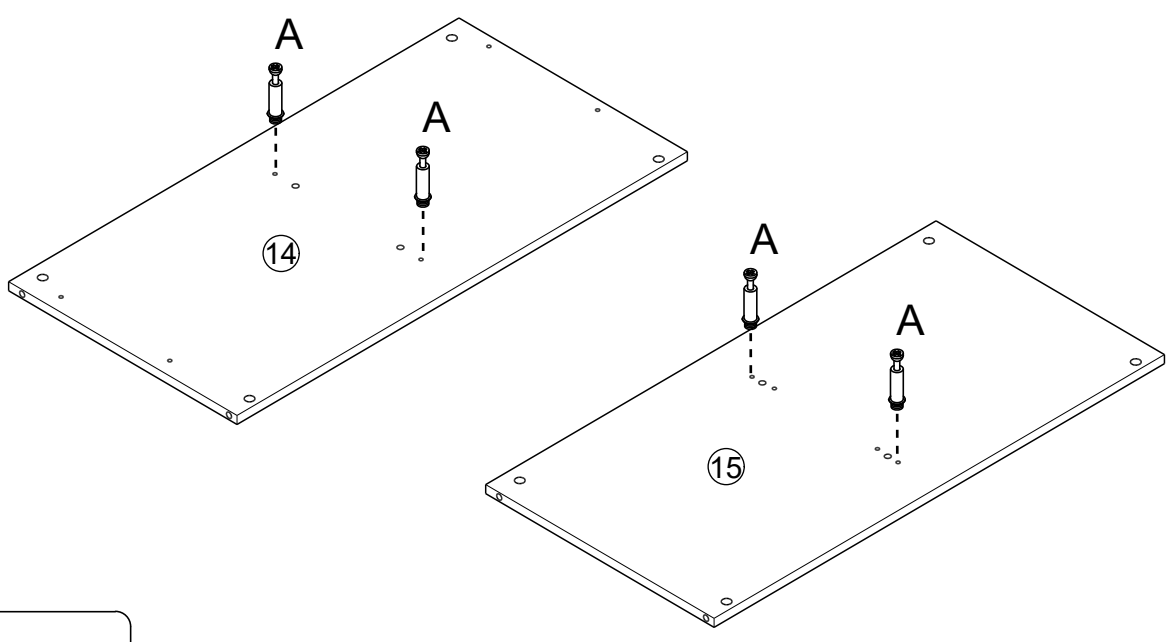

2

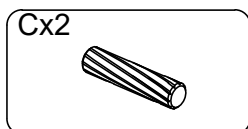
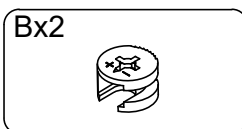
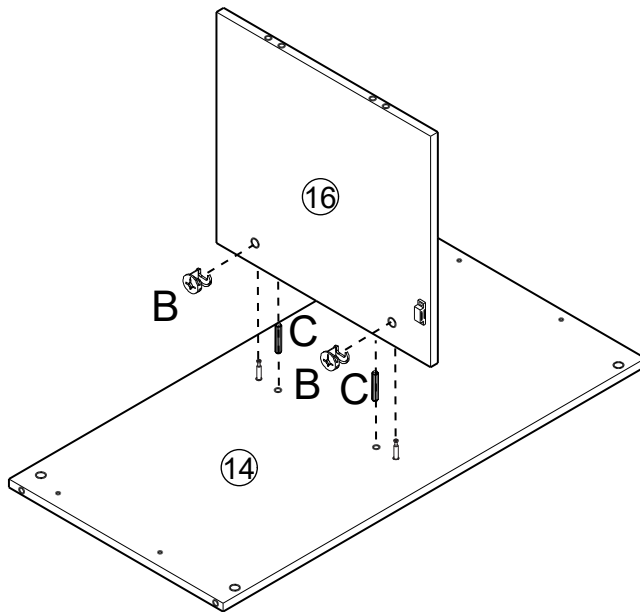
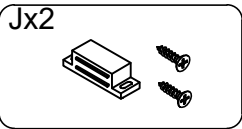
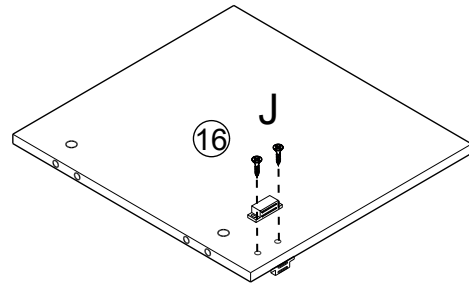
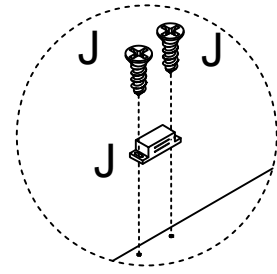
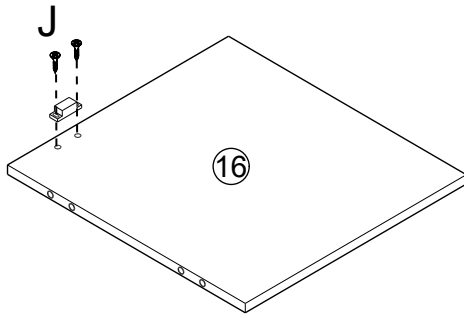

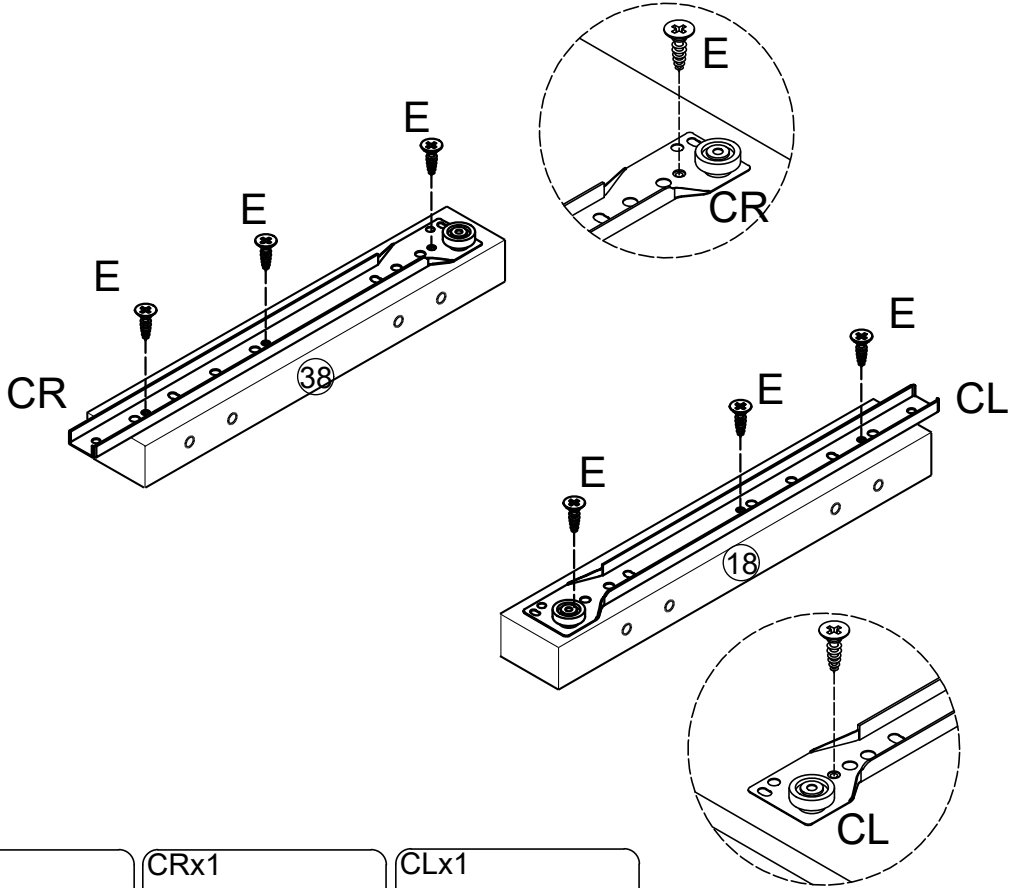



- Ex6 
- CRx1 
- CLx1 

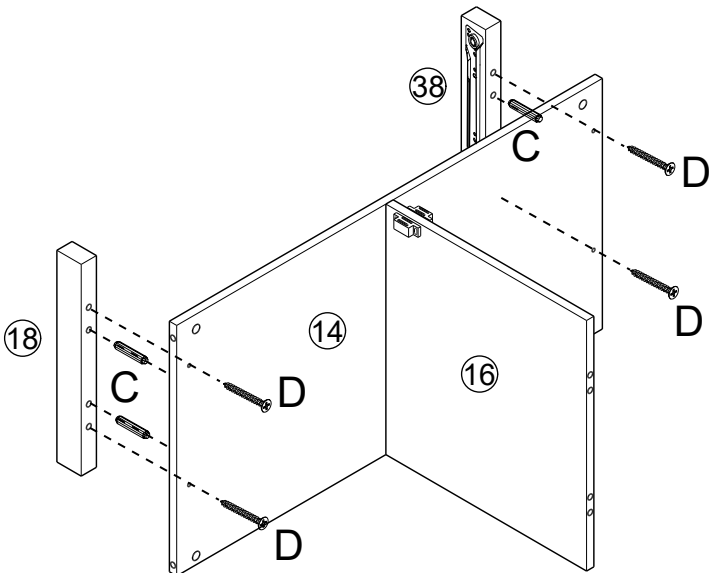

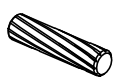
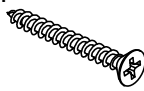
- Cx4 
- Dx4 

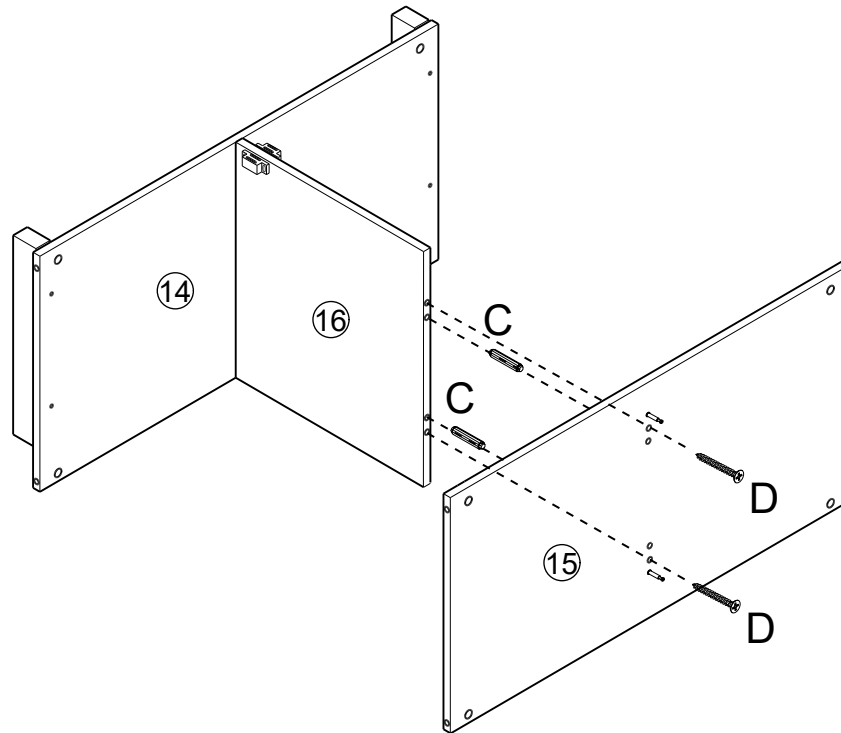

Cx2



Dx2

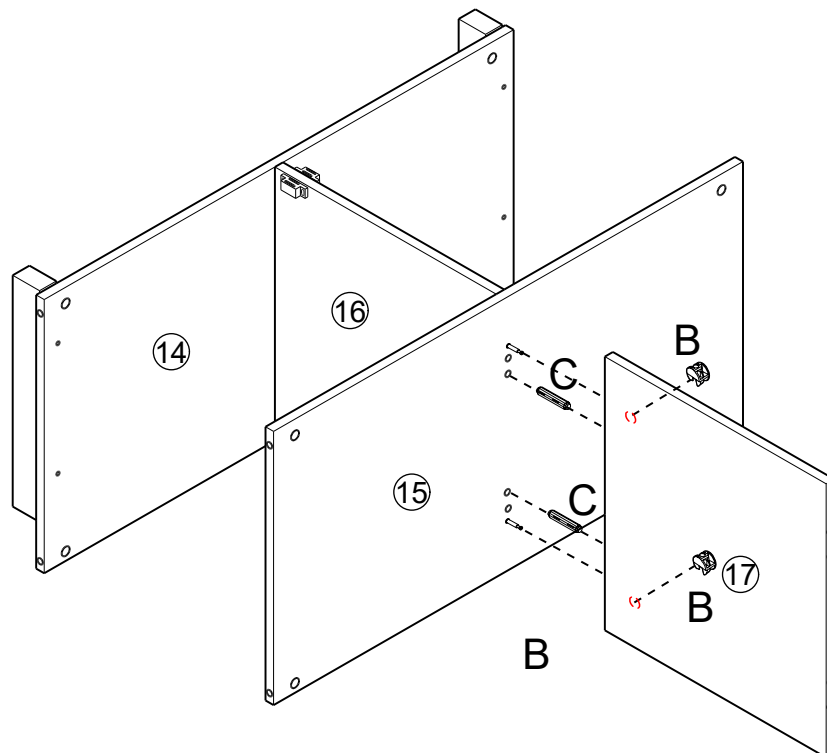
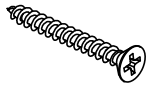

Bx2



Cx2



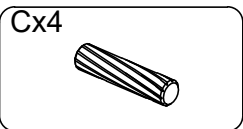
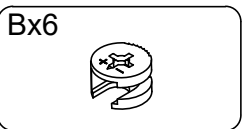
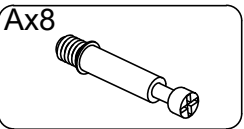
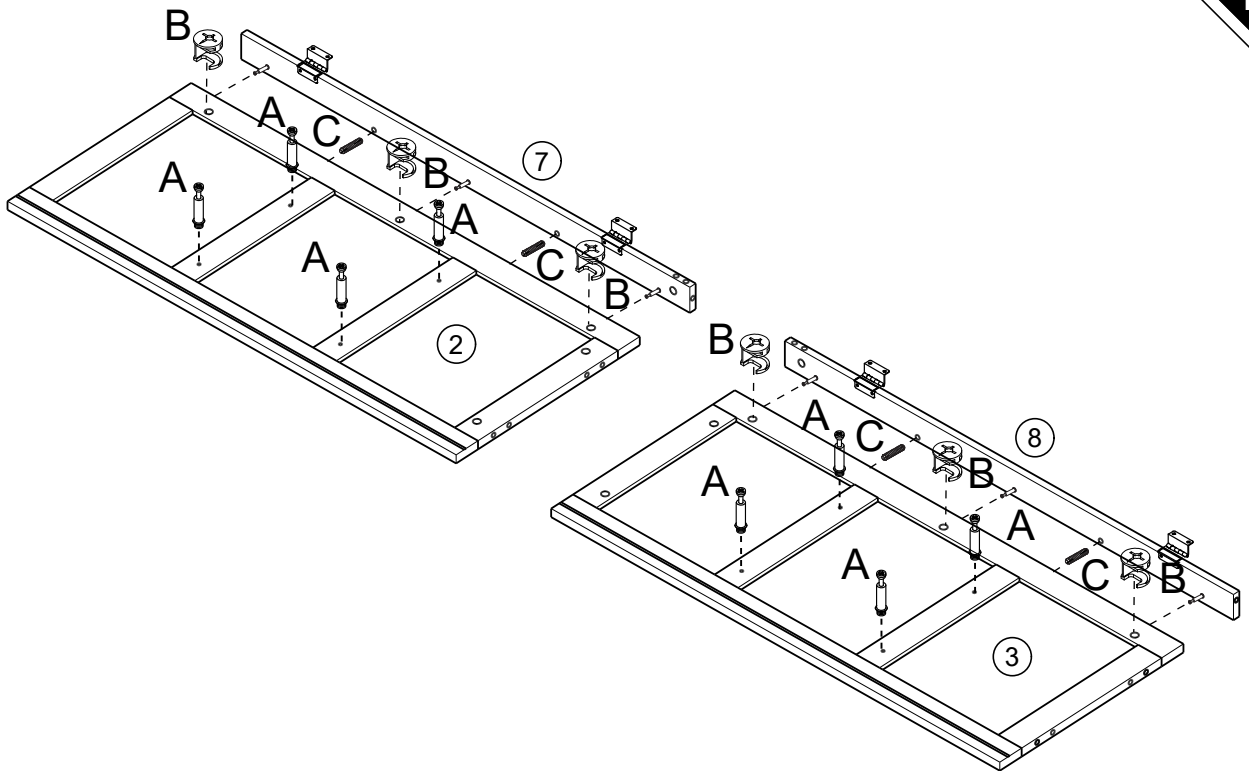
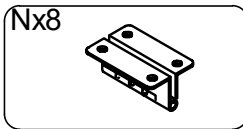
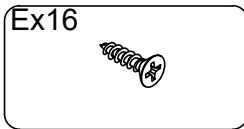
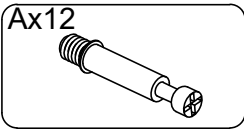
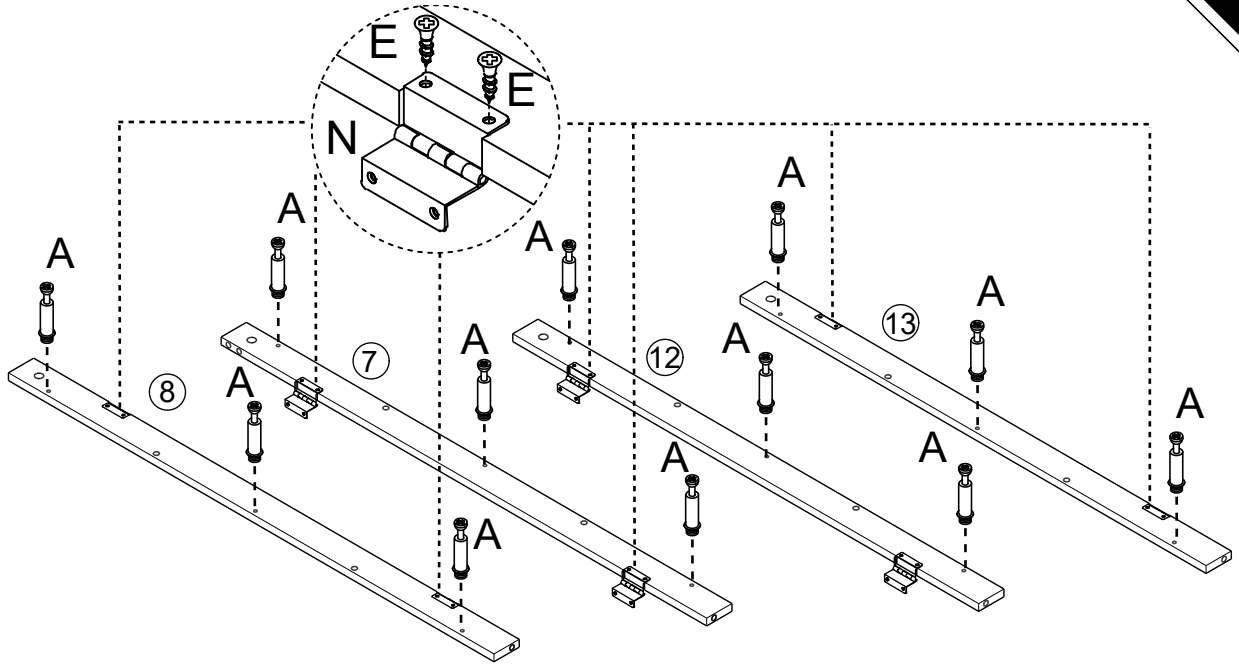

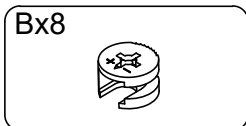
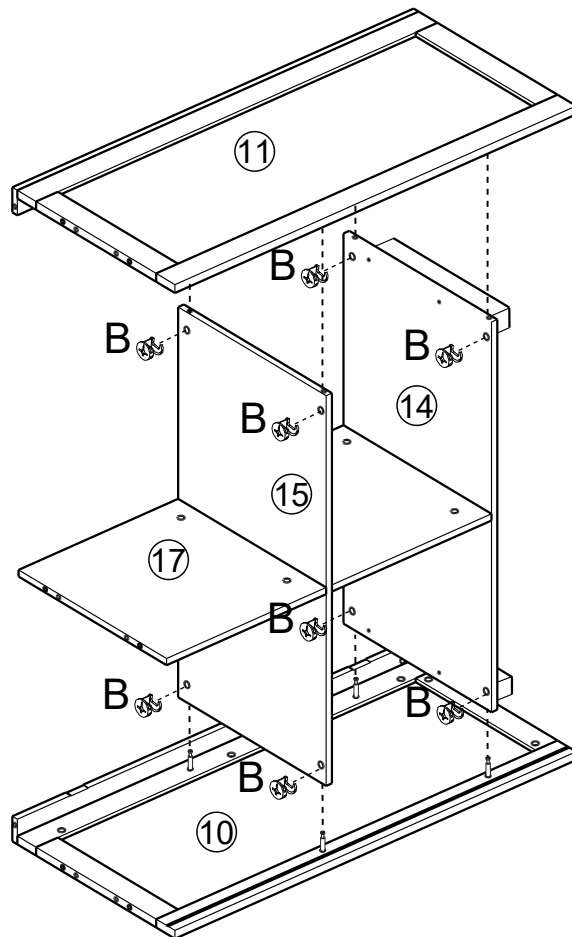
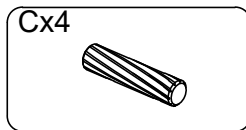
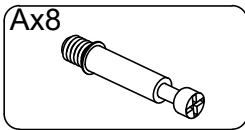
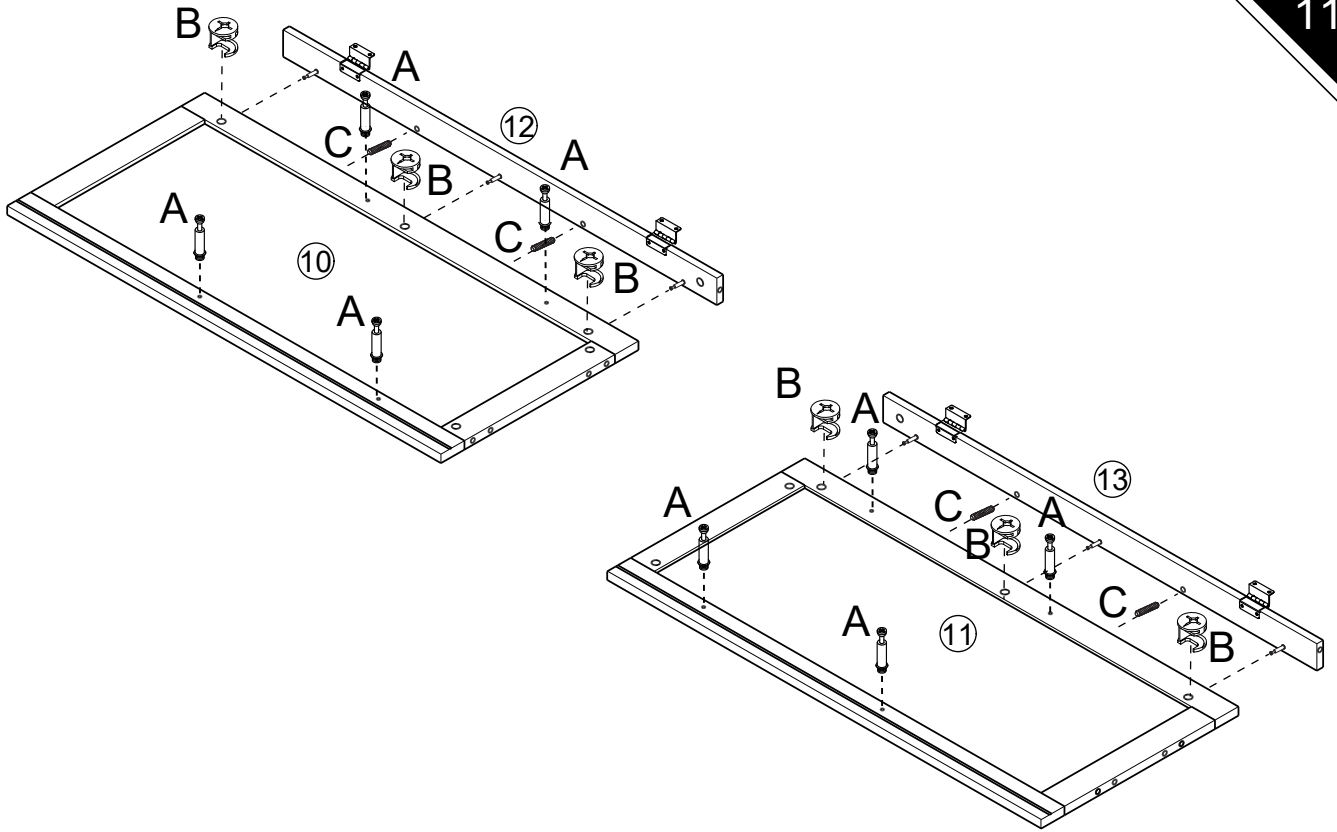

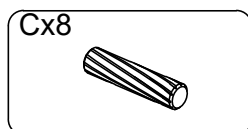
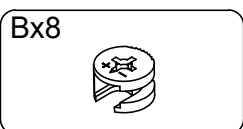
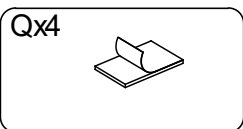
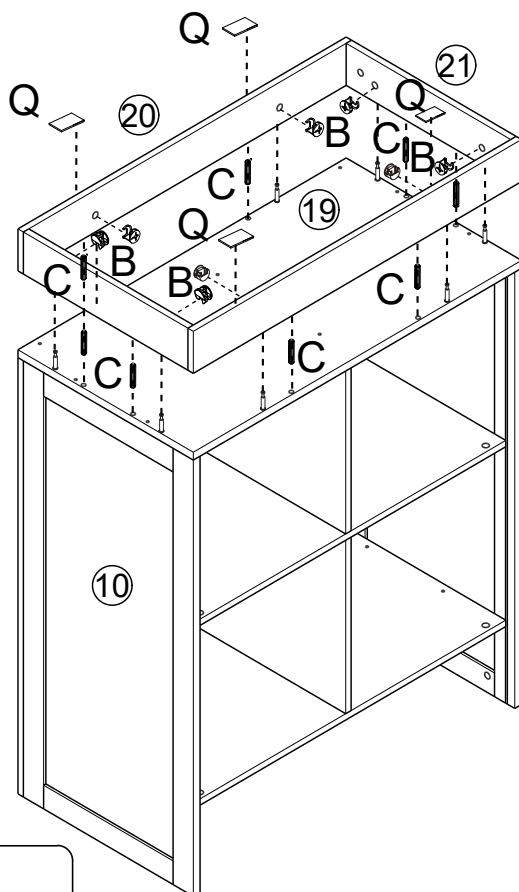
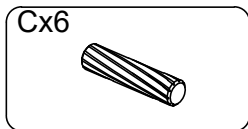
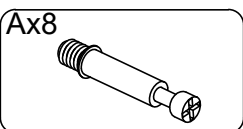
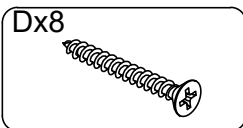
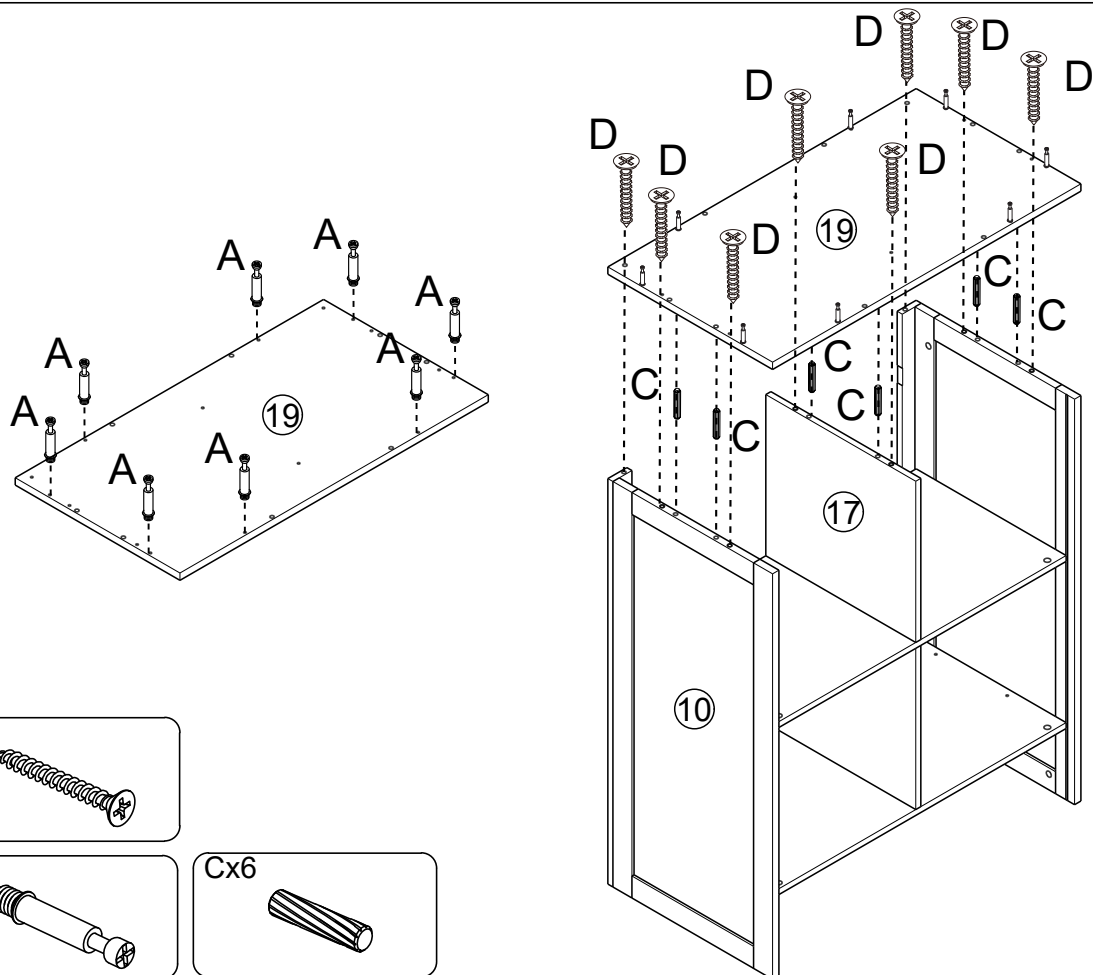

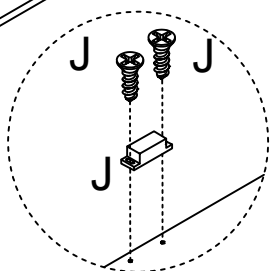
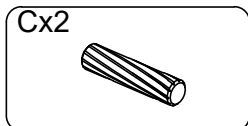
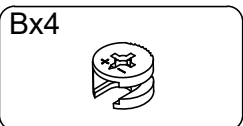
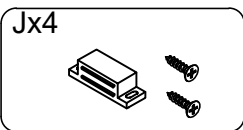
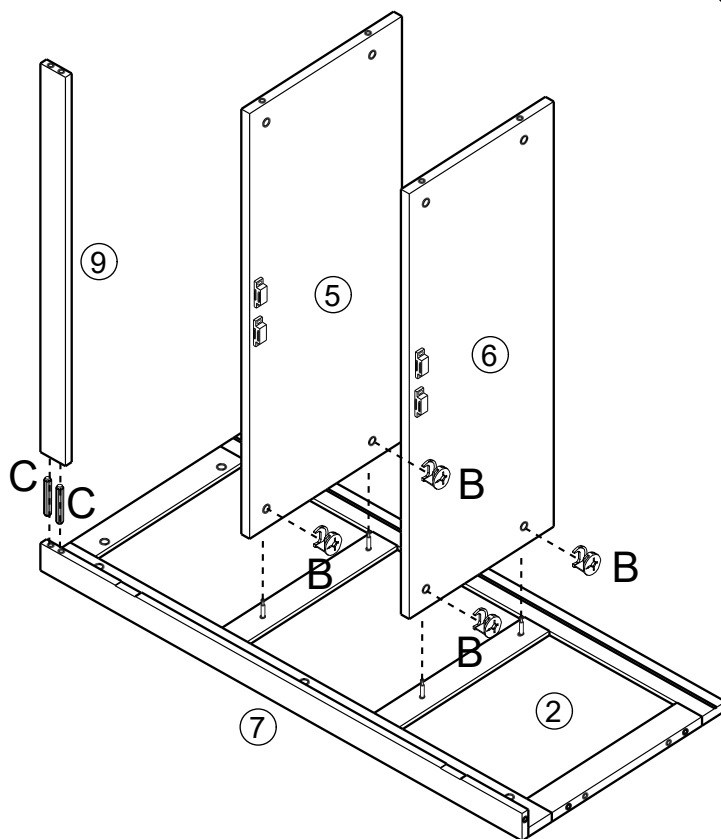
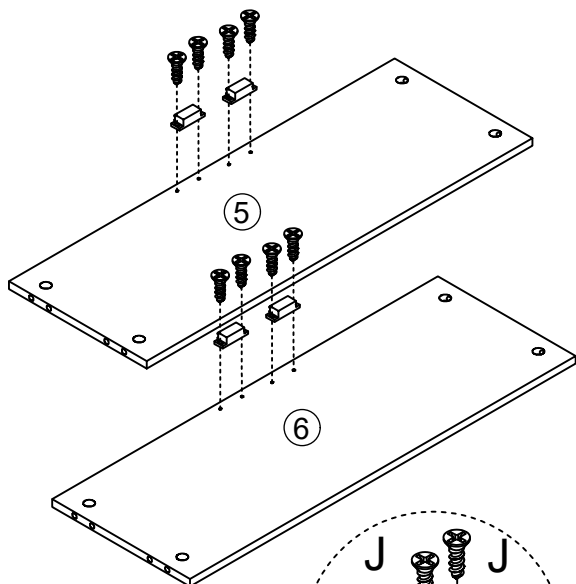
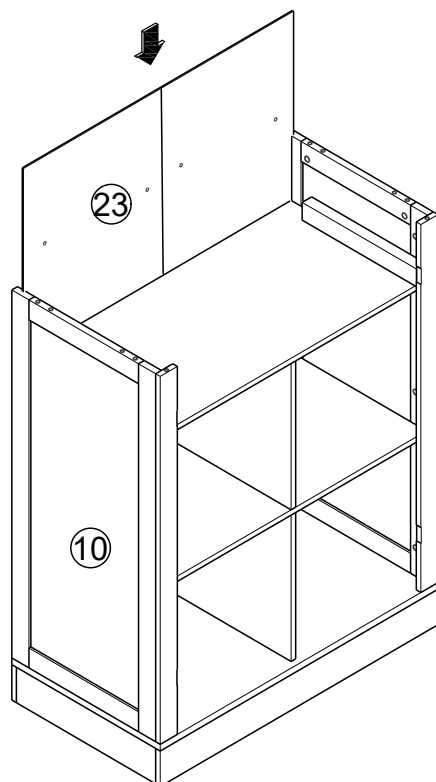

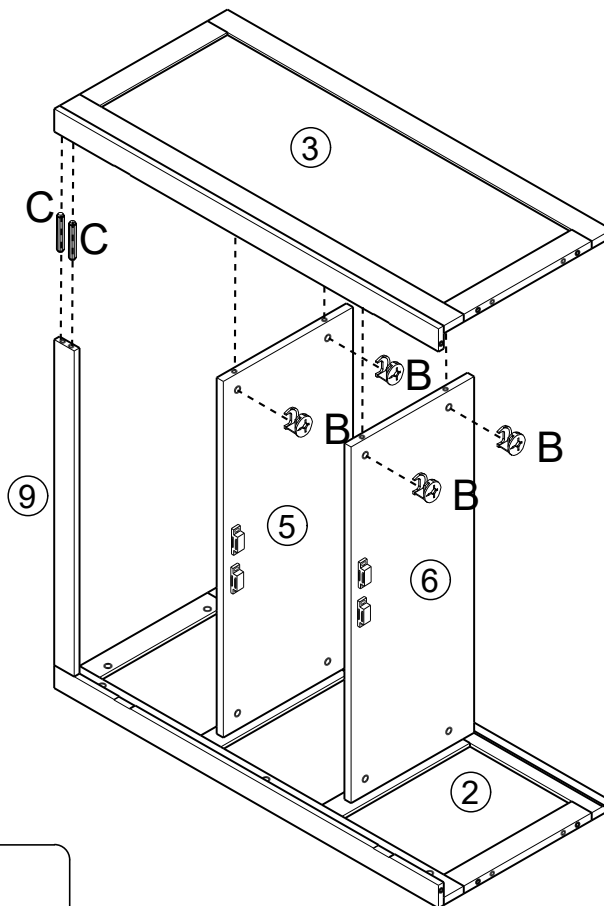

Bx4



Cx2

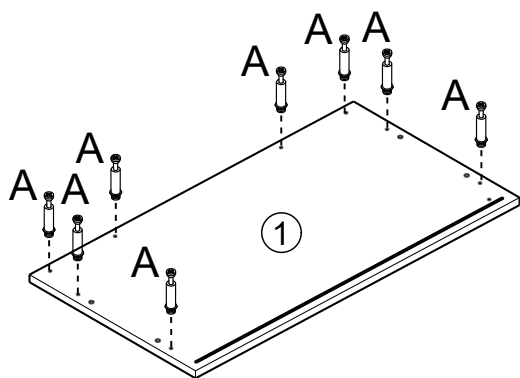

Ax8

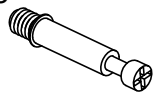

Bx8



Cx4

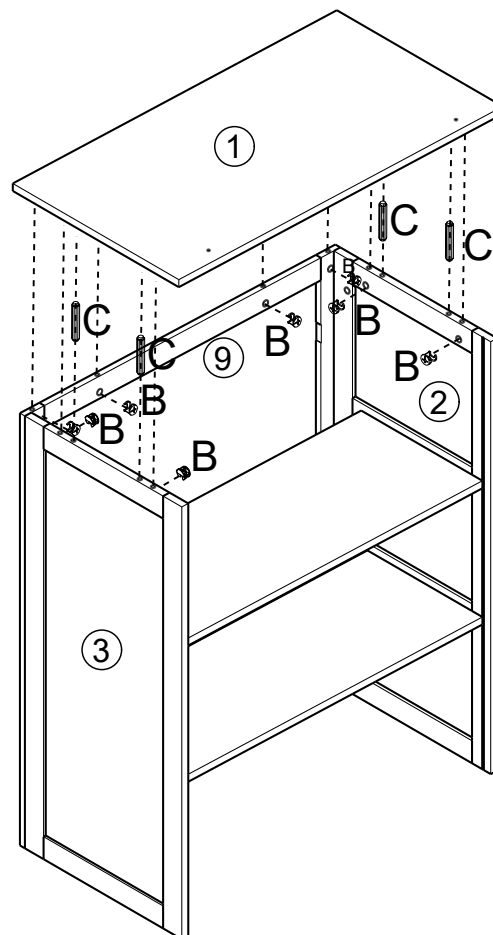

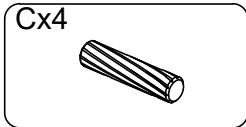
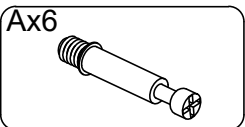
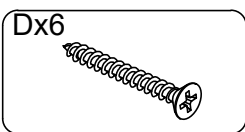
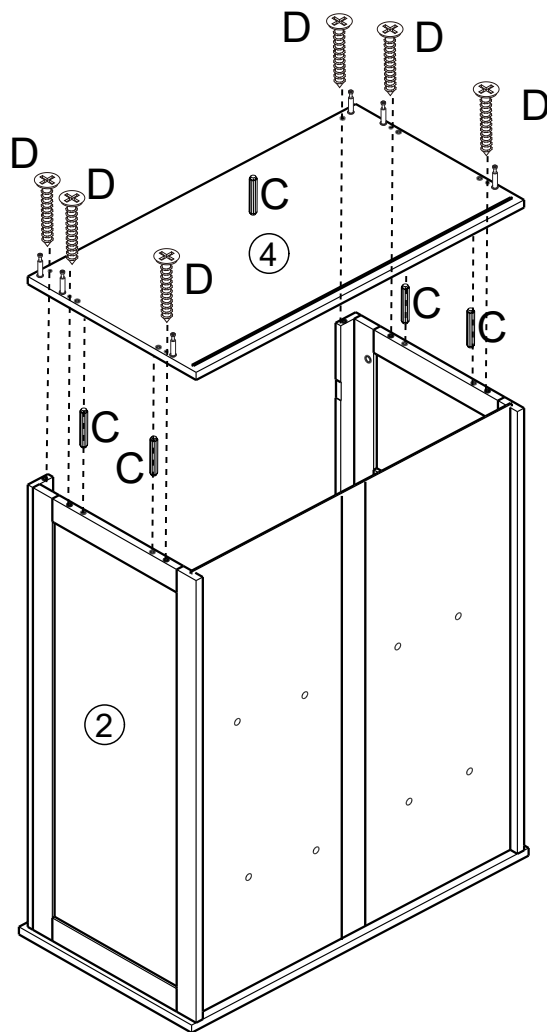
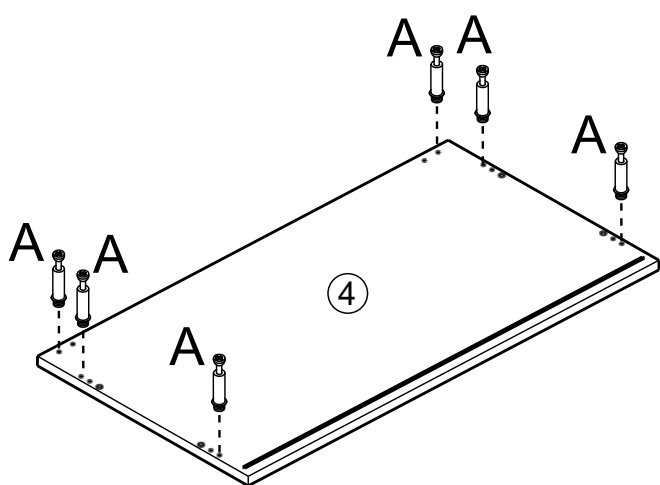
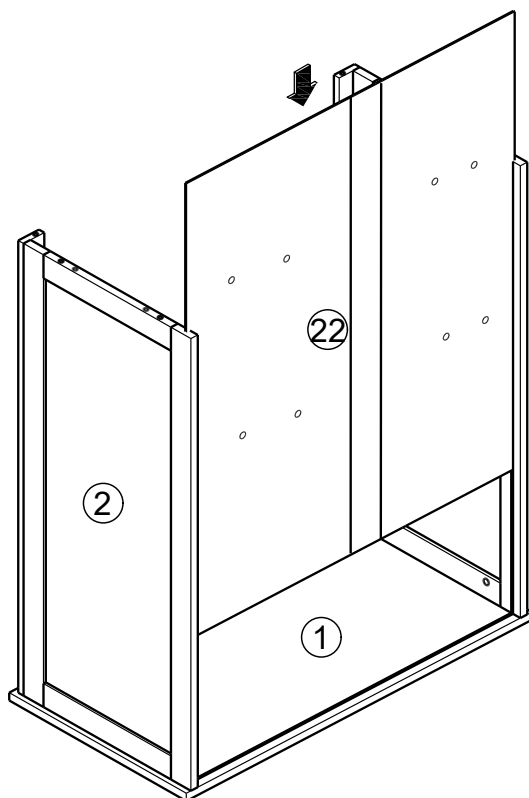

Note: Need two or more peoples to complete

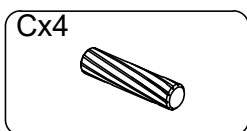
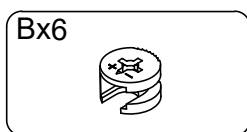
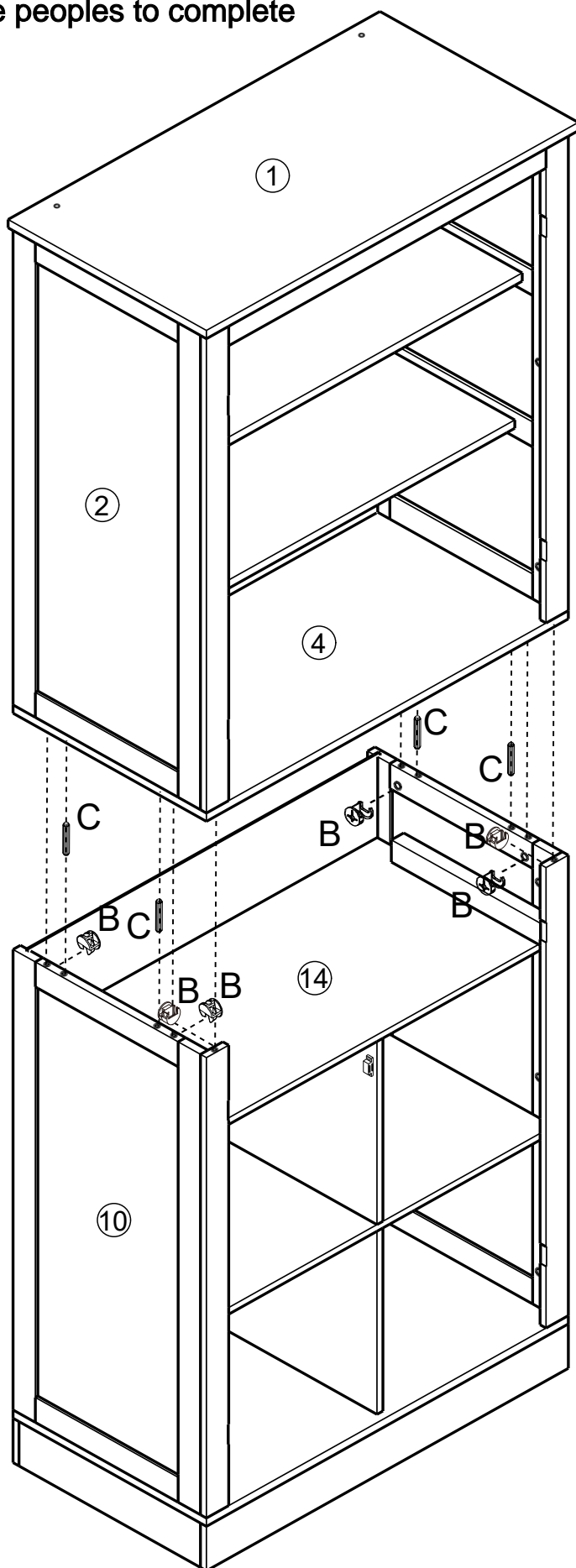

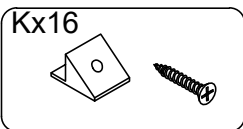
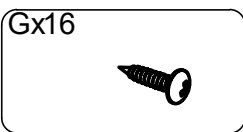
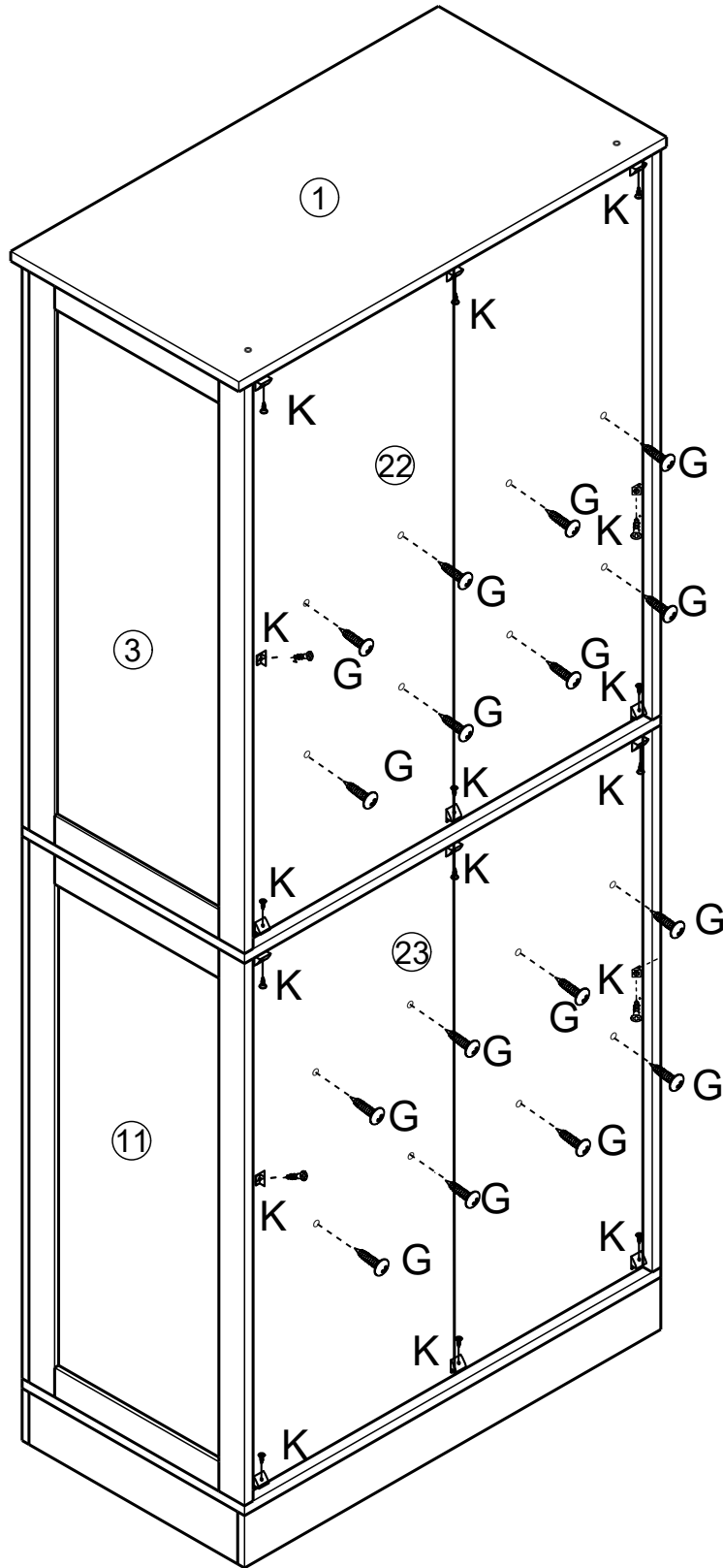
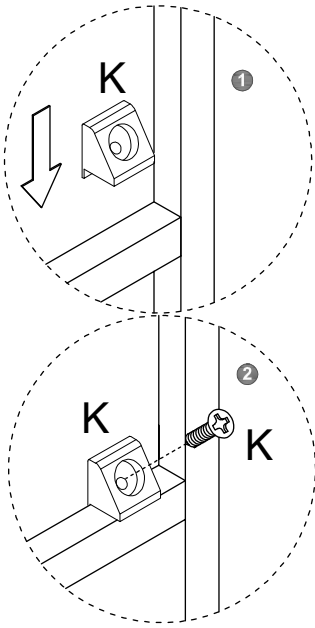

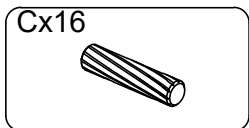
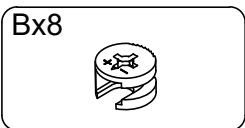
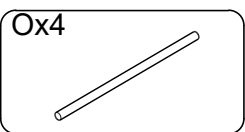
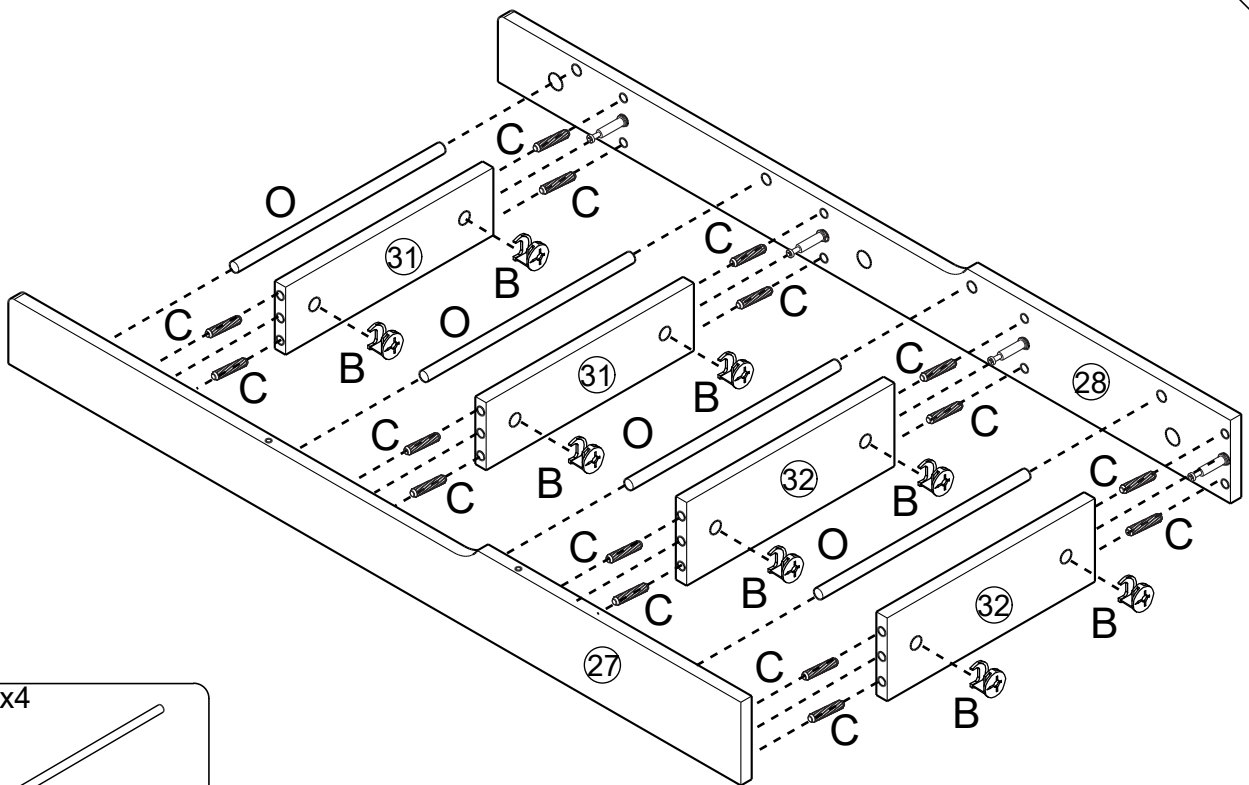
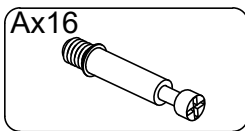
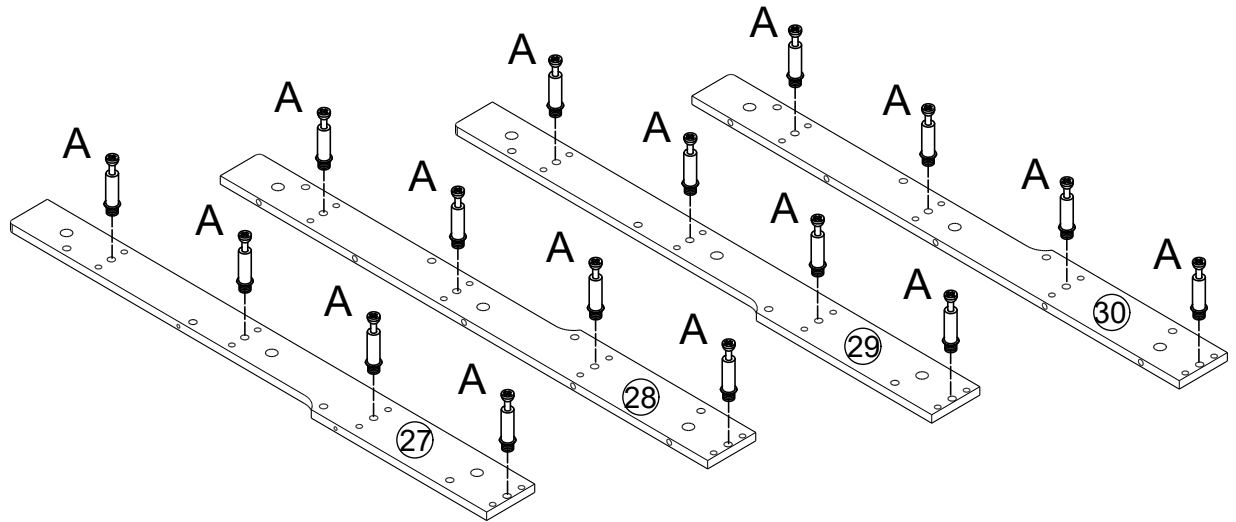

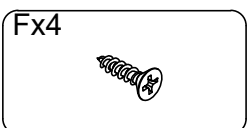
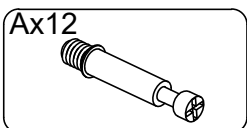
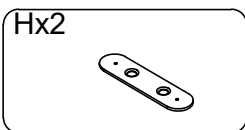
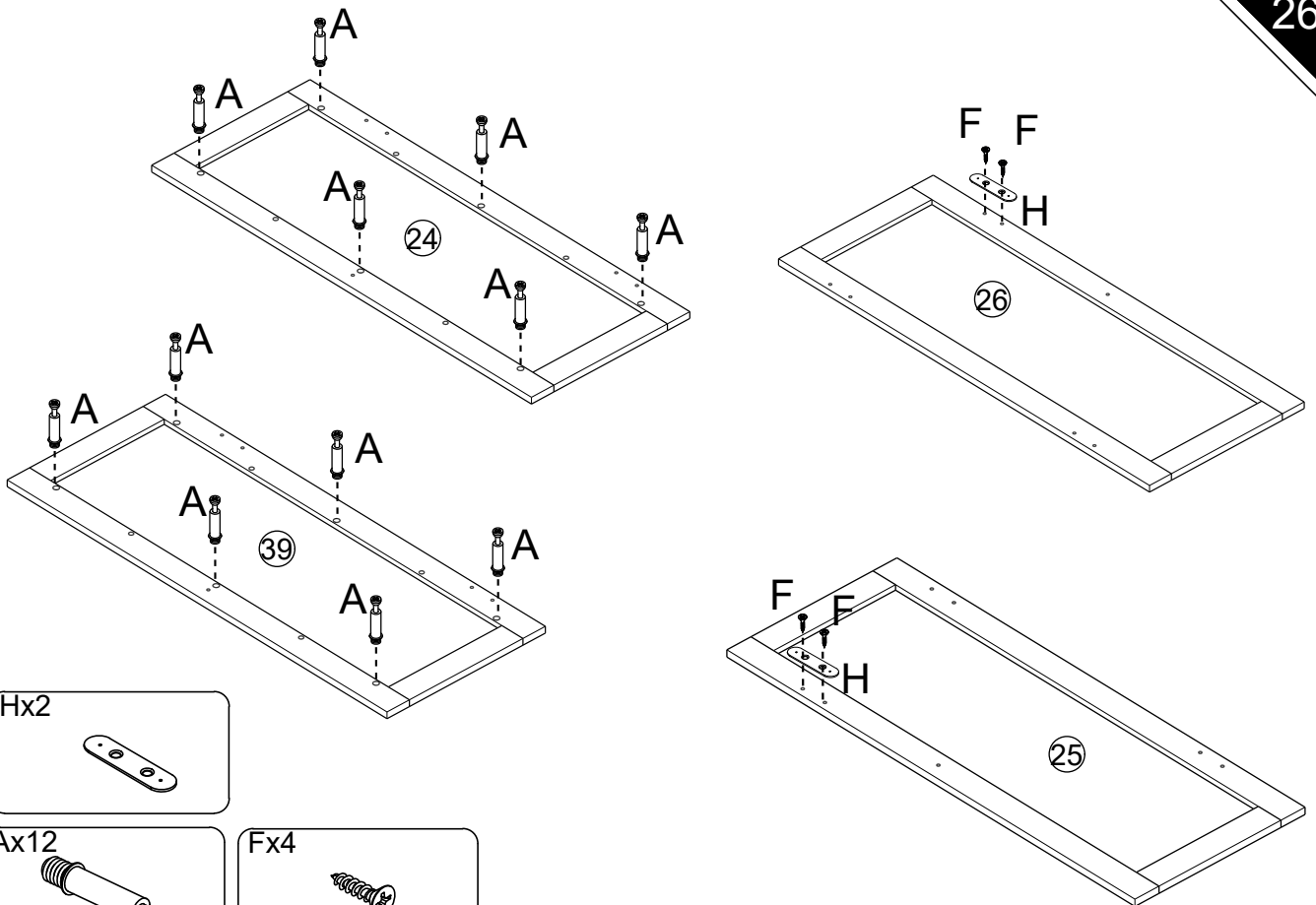
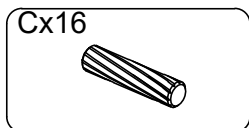
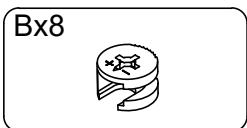
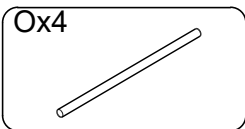
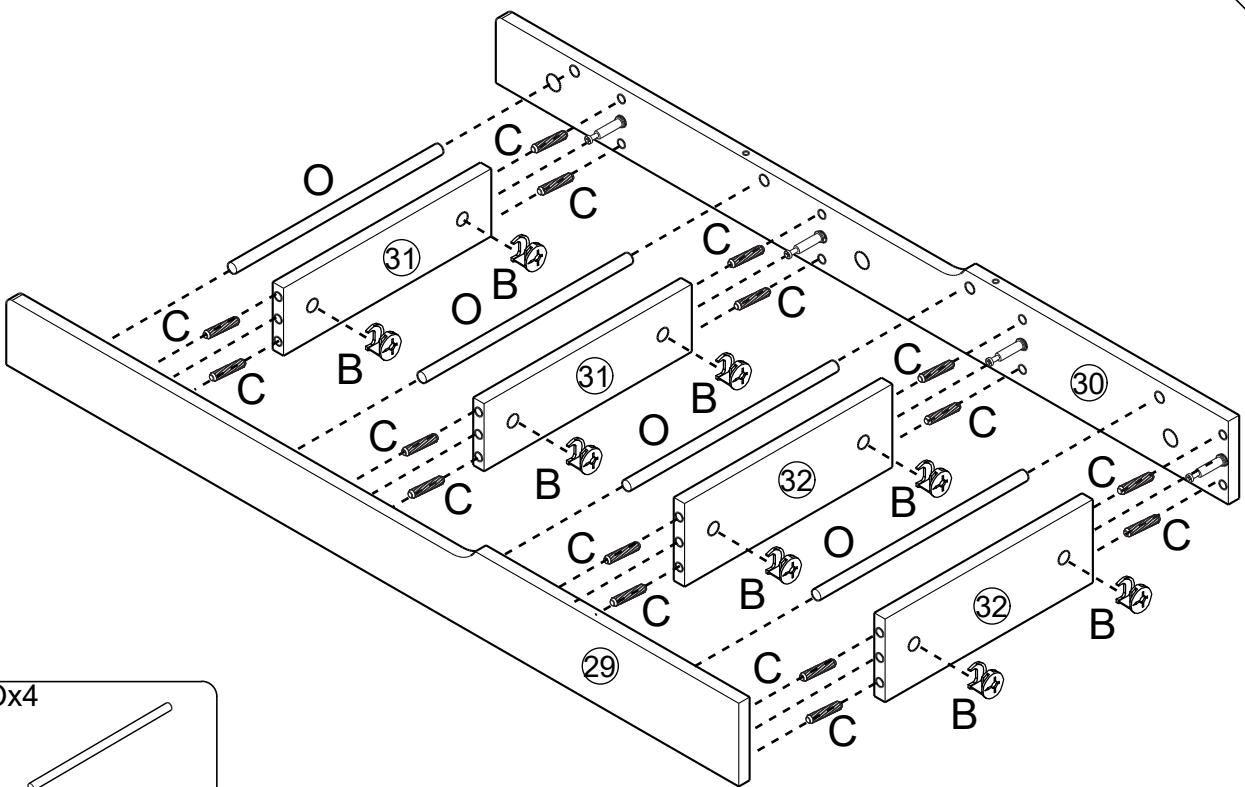

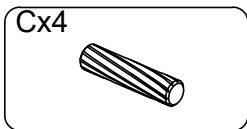
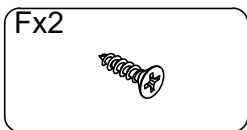
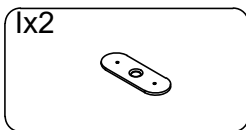
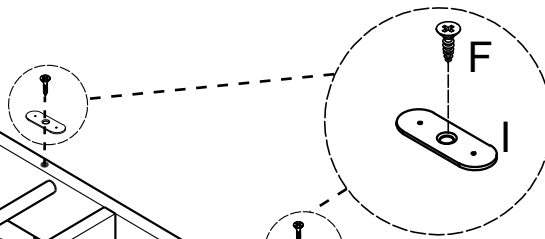
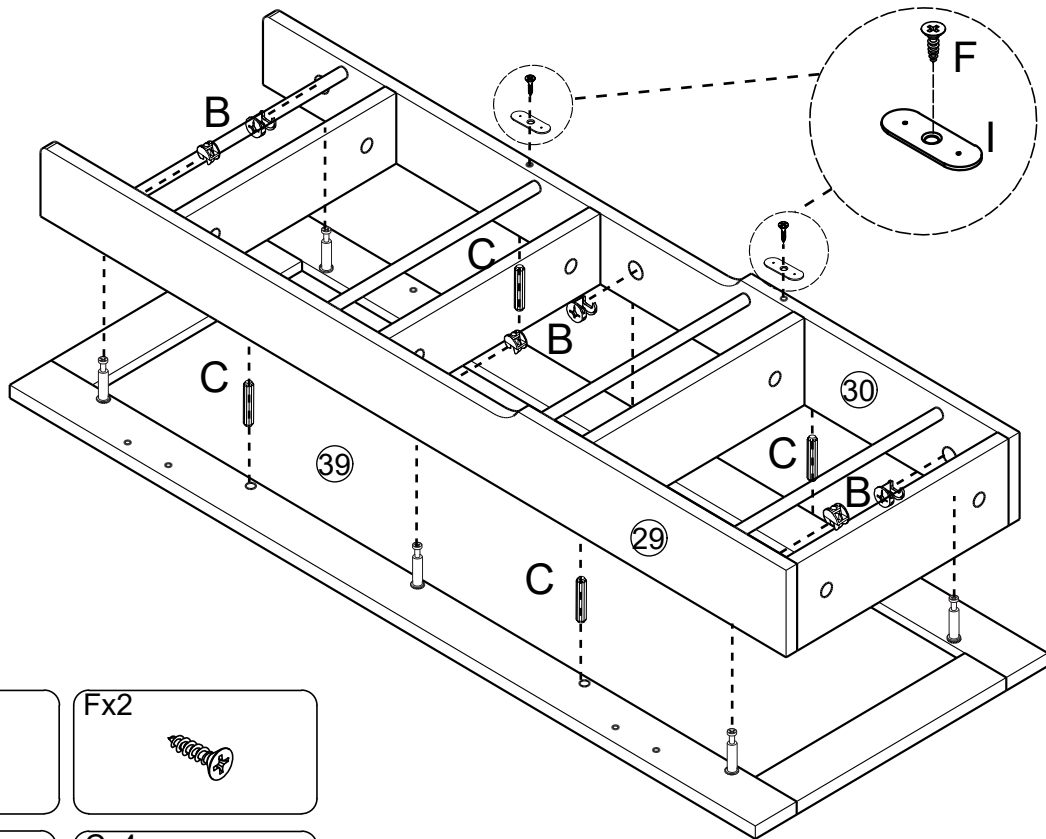
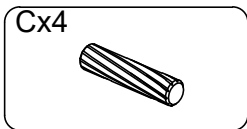
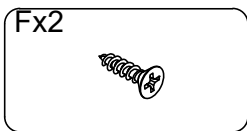
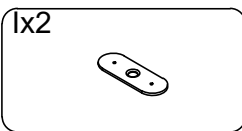
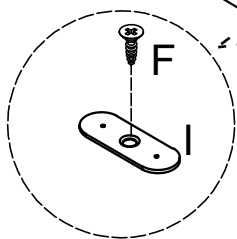
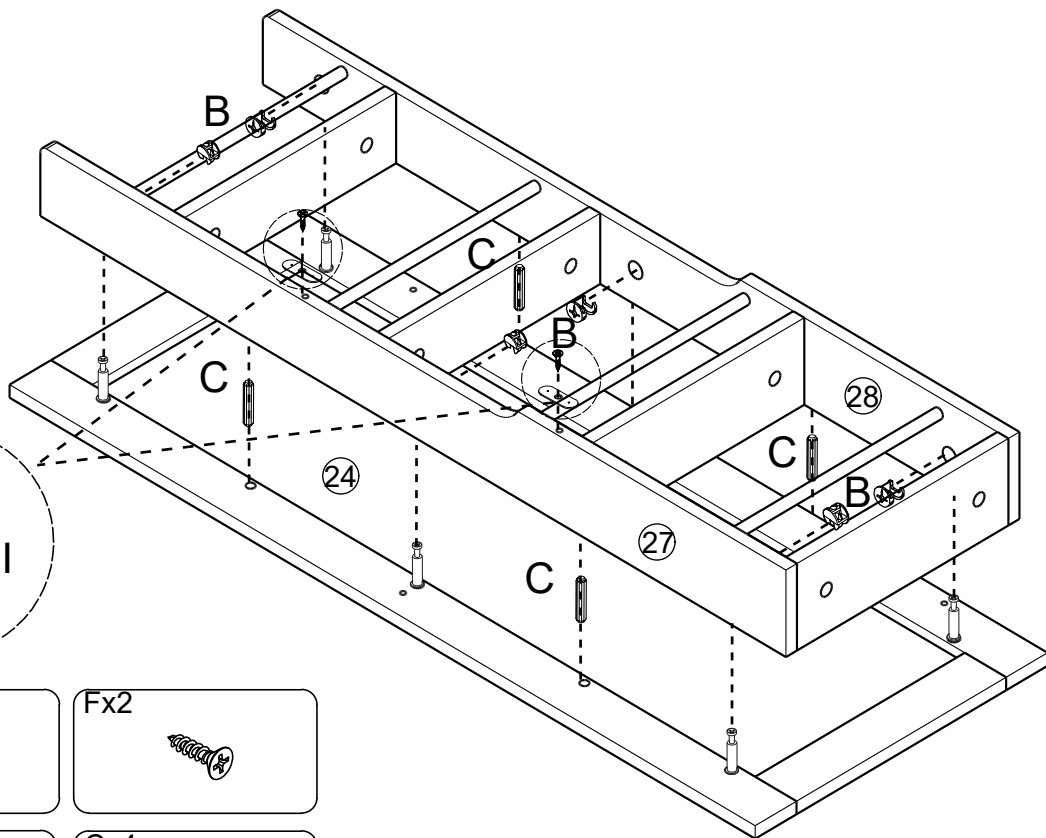

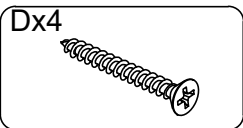
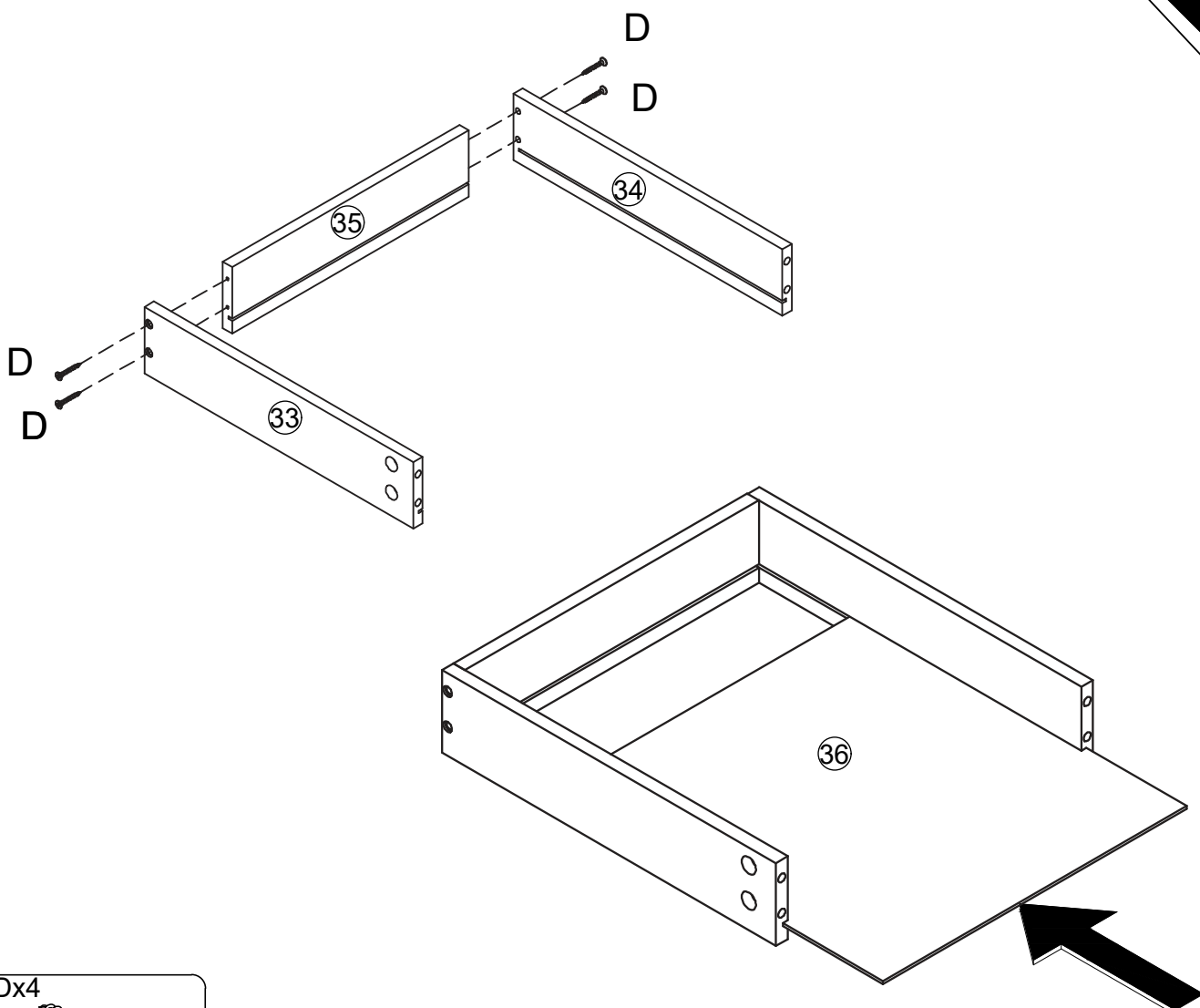
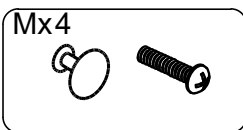
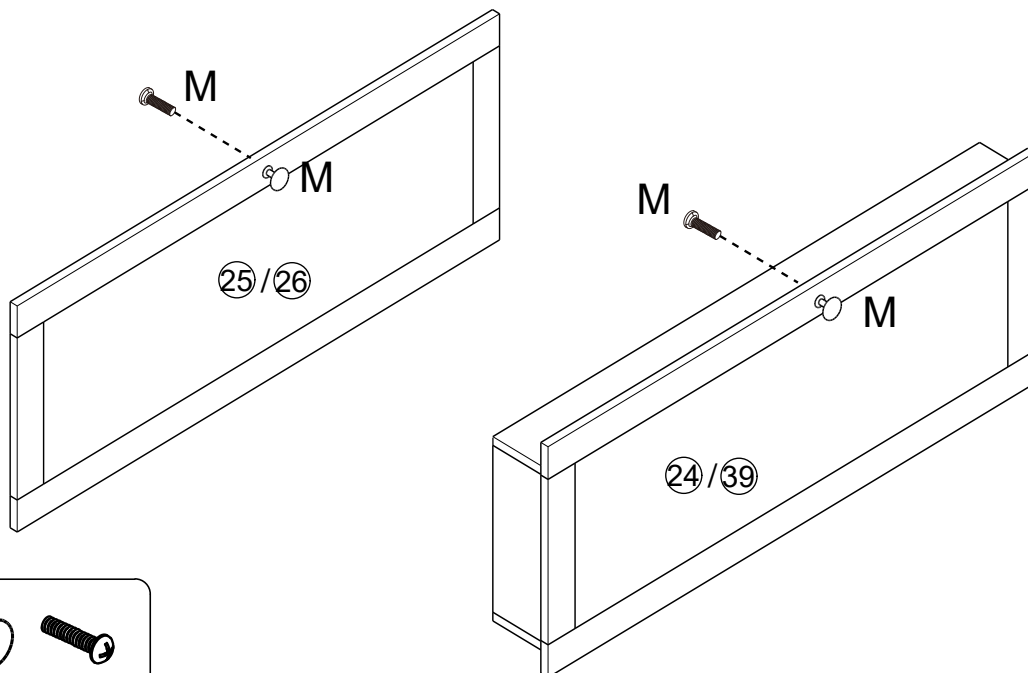

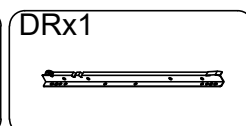
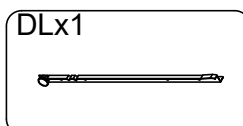
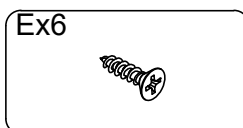
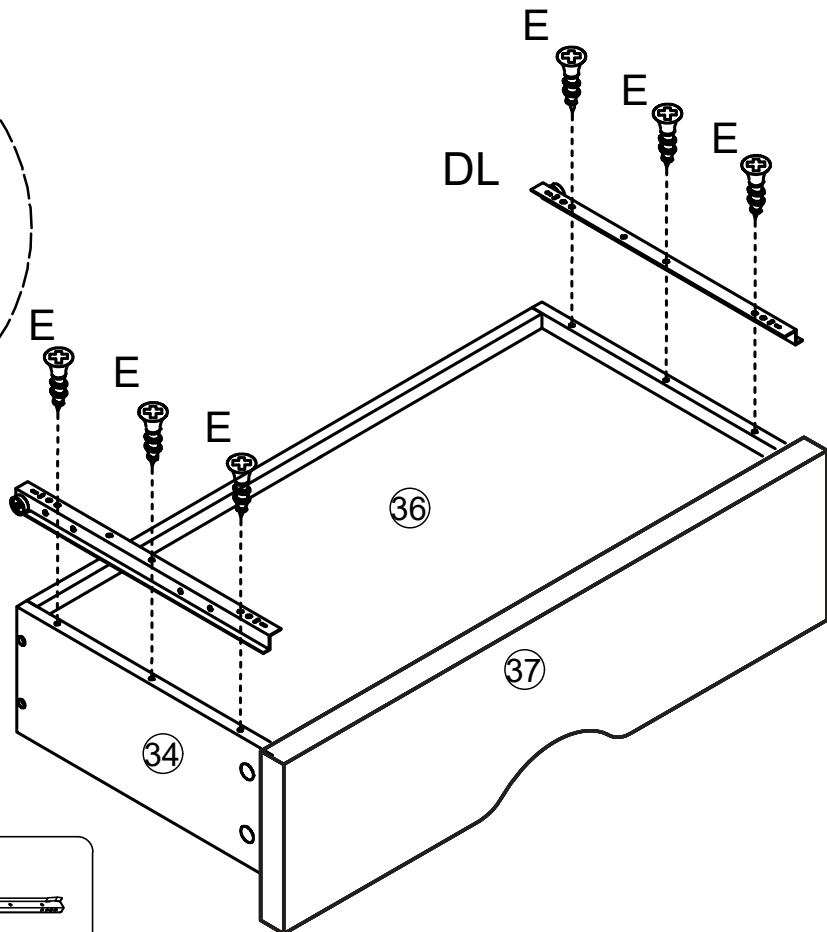
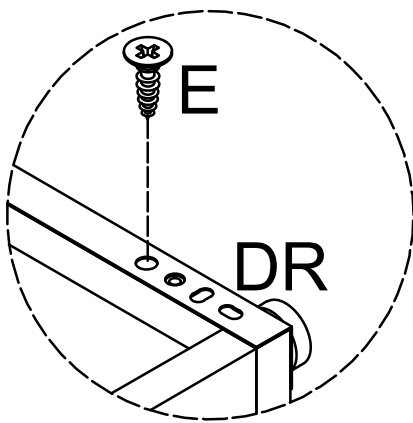
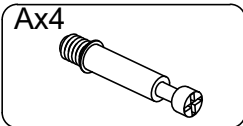
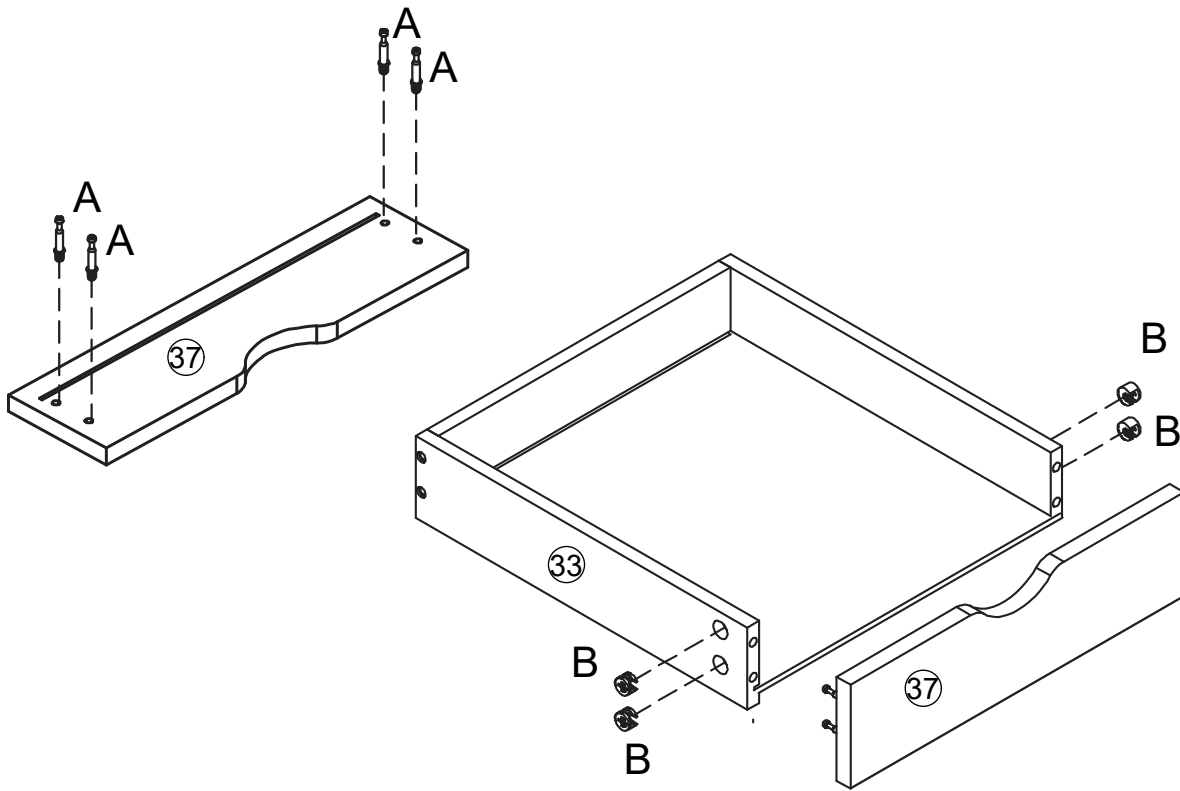

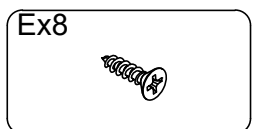
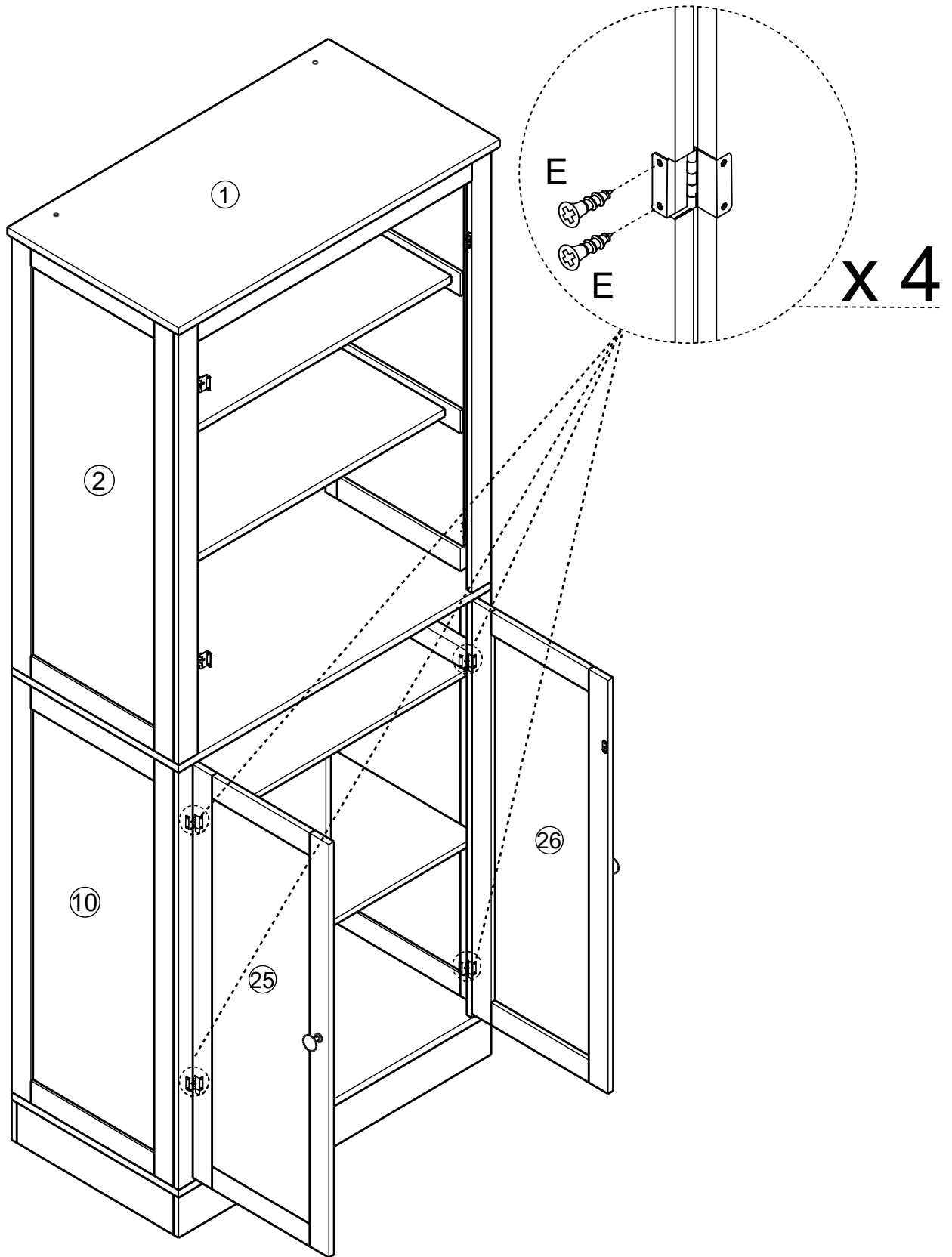

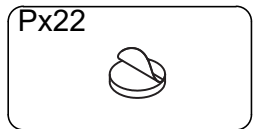
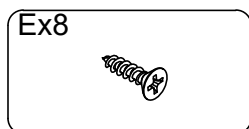
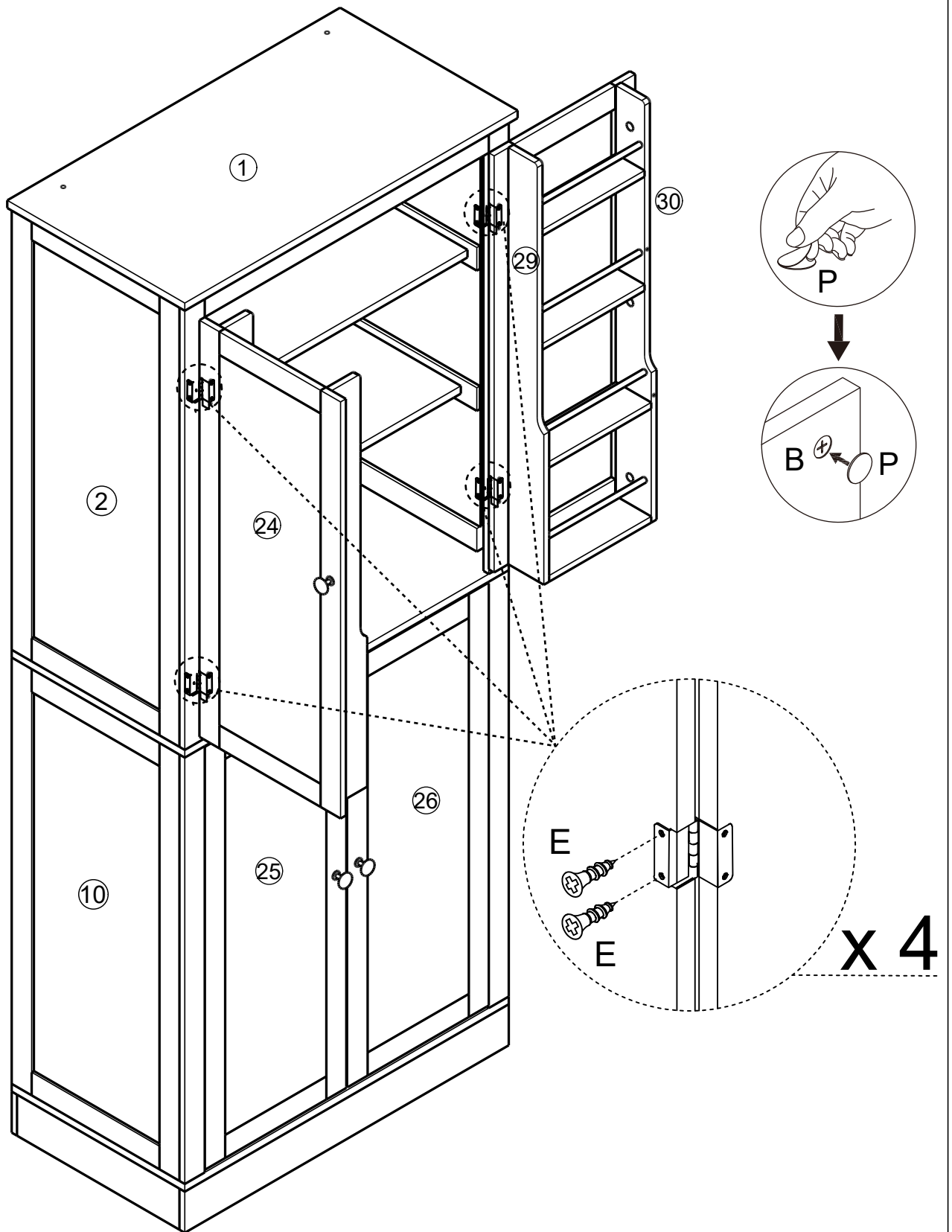

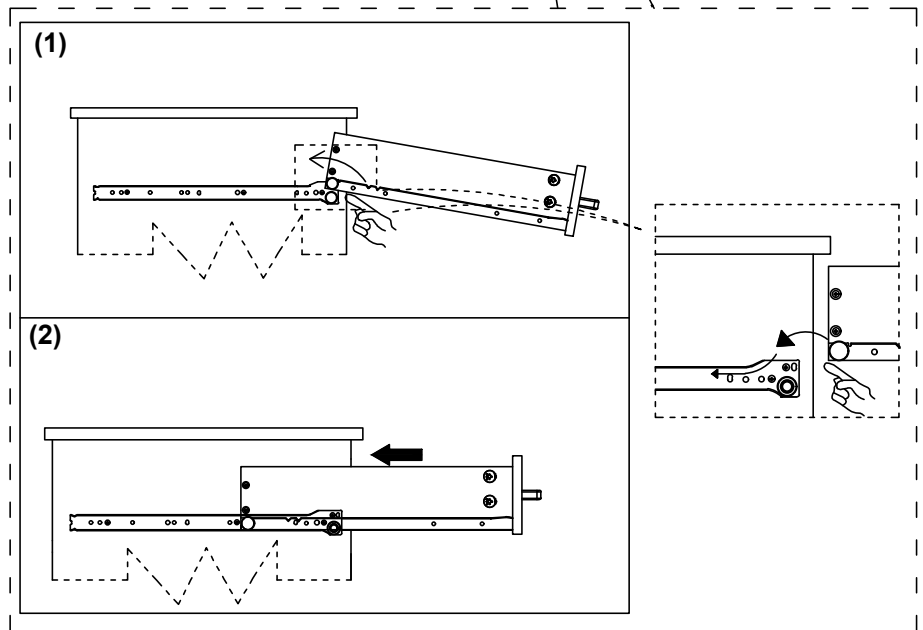
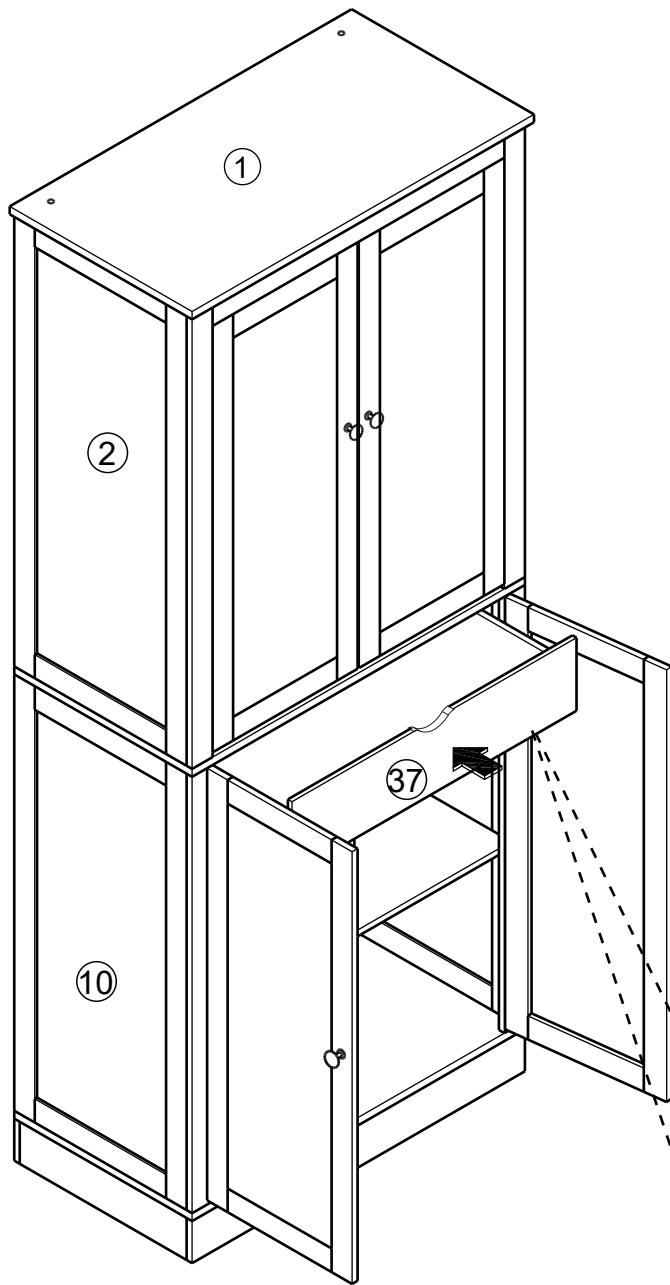

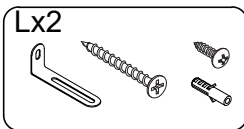
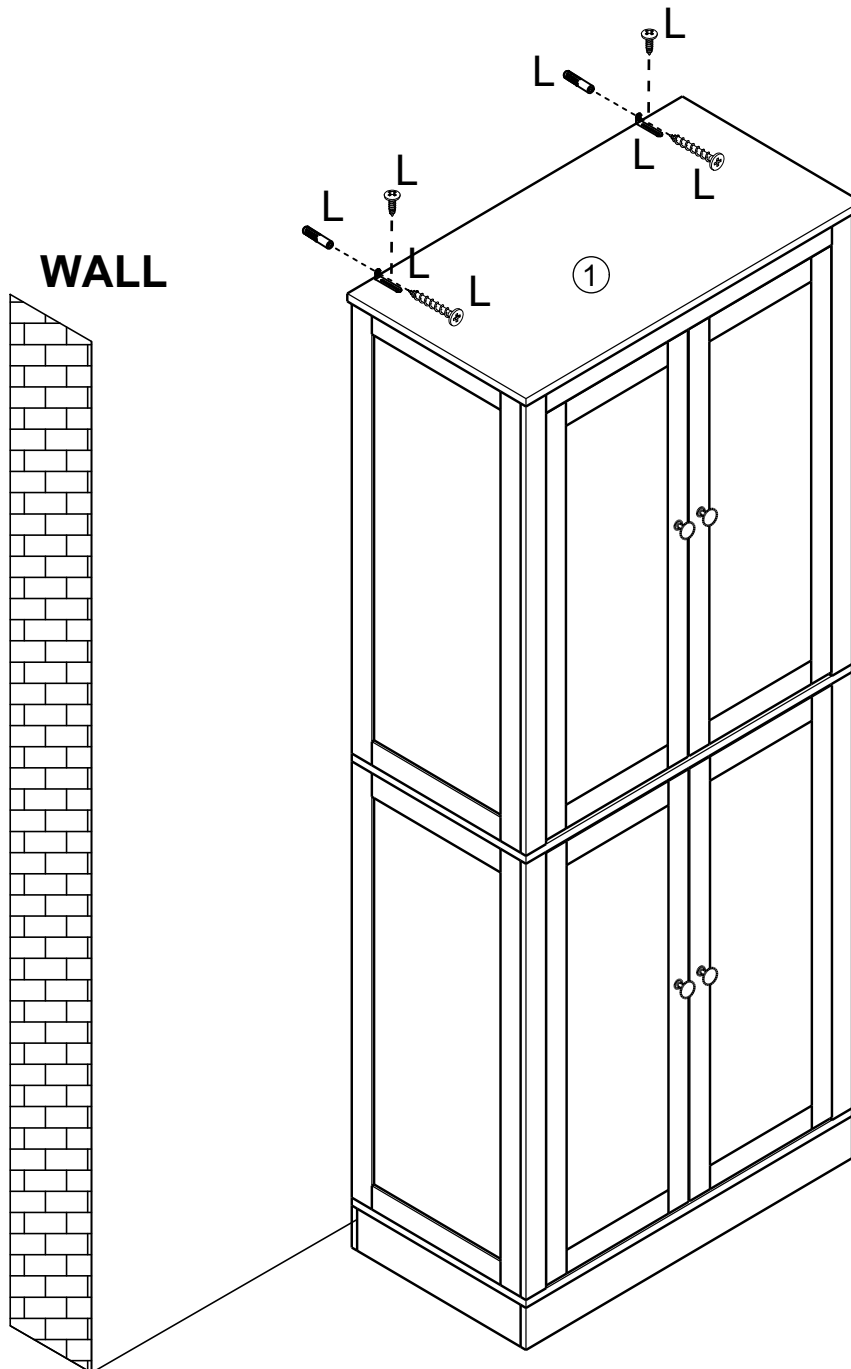

EN_ If it is a solid wall, please use expansion and self-tapping screws, if it is a wooden wall, only use self-tapping screws, please do not over tighten the screws

FR_ Si le mur est massif, veuillez utiliser des chevilles à expansion et des vis autotaraudeuses, mais s'il s'agit d'un mur en bois, utilisez uniquement des vis autotaraudeuses et ne serrez pas trop les vis.

ES_ Para una pared sólida, utilice los tornillos de expansión y autorroscantes. Para una pared de madera, utilice exclusivamente los tornillos autorroscantes, no los apriete demasiado.

DE_ Wenn es sich um eine Massivwand handelt, verwenden Sie bitte Dehnungs- und selbstschneidende Schrauben. Wenn es sich um eine Holzwand handelt, verwenden Sie nur selbstschneidende Schrauben, bitte ziehen Sie die Schrauben nicht zu fest an.

IT_ Se si tratta di un muro solido, utilizzare sia viti ad espansione che autofilettanti. Se si tratta di una parete in legno, utilizzare solo viti autofilettanti, non stringere eccessivamente le viti.