

Owner Manual

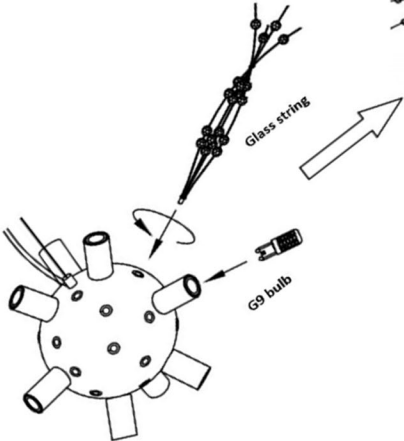

EXPLODED

VIEW

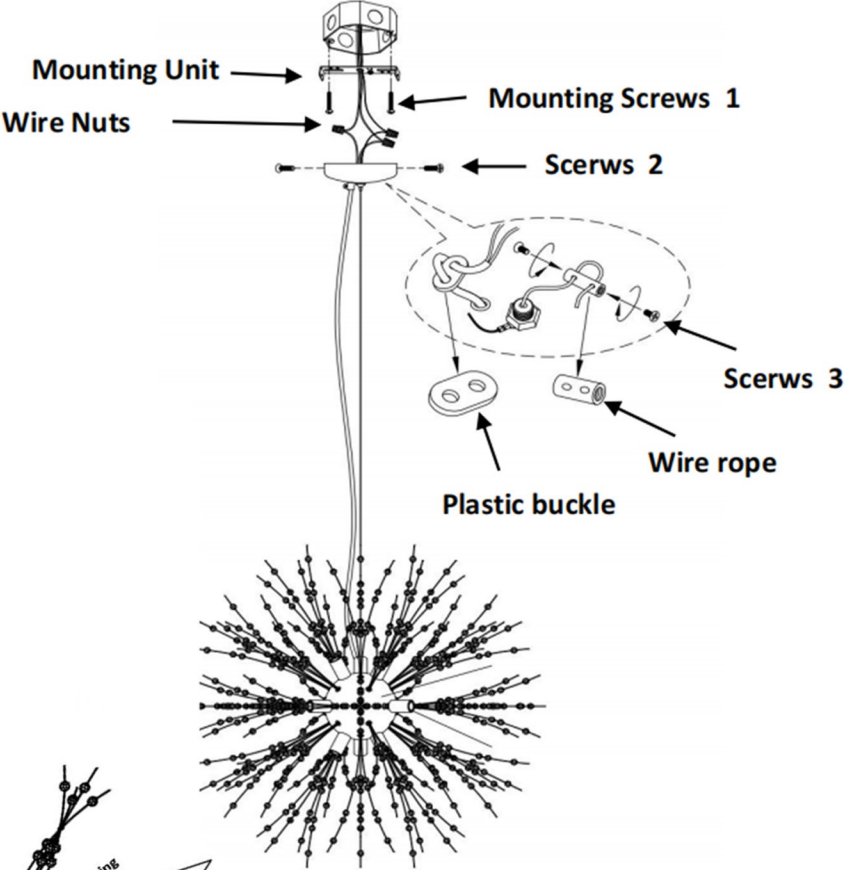

The bundled plastic zip ties on the decorative bead clusters should only be cut off after they are fully installed on the lamp body.

PARTS

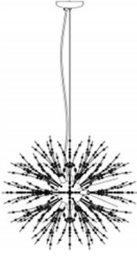

Fixture

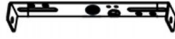

Mounting Unit



Mounting Screws 1



Wire Nuts



Screws 2

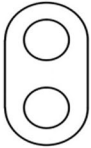

Plastic buckle

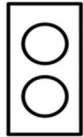

Wire rope



Screws 3



Bead cluster
48pcs



G9 bulb 9pcs

TOOLS REQUIRED



Ladder



Safety
Goggles



Electrical
Tape



Phillips
Screwdriver



Flathead
Screwdriver



Wire
Cutter



Wire
Stripper

ATTENTION

Please inspect the wires before installation, if the wire shows any cut or abrasion, or has exposed copper wires, **DO NOT** use the fixture, it might be caused during transportation or defect product.

Before starting installation of the fixture, please remove the previous fixture (if any).

Disconnect the power by turning off the electric break for your property (Please ask for professional help if needed).

MAINTENANCE AND WARNING

Verify the lamp model suits the environment (indoor/outdoor, IP rating) and check all accessories (body, screws, cord, manual).

Only use with bulbs of the recommended type and wattage. Exceeding the maximum wattage may cause overheating or fire.

Do not install the fixture if any part is damaged or missing. Contact the manufacturer or seller for replacement parts.

The fixture may become hot during use. Allow to cool before handling.

Clean dust accumulation in recessed lamps regularly (to prevent overheating), but only when powered off; never rinse with water.

If the fixture includes a dimmer switch, ensure it is compatible with the fixture before installation.

Do not modify the fixture in any way; tampering with electrical components can result in malfunction or risk of fire.

step 1

Unscrew the ball nut from the mounting unit
Use the mounting screws to attach the mounting unit
to the junction box

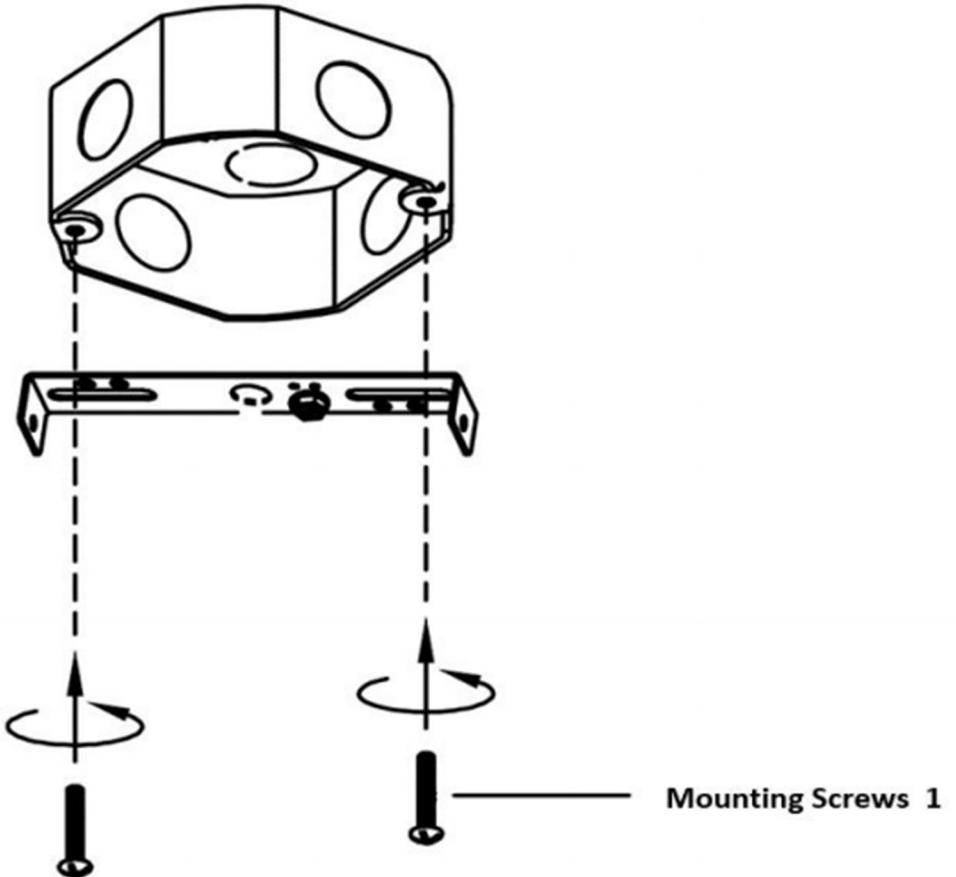

step 2

Make the electrical connection from the junction box (not included) to the fixture. Connect the ground wire to the mounting unit using the preinstalled green ground screw. Next, connect the live wire, neutral wire and ground wires with the supplied wire nuts. Secure with electrical tape.

