

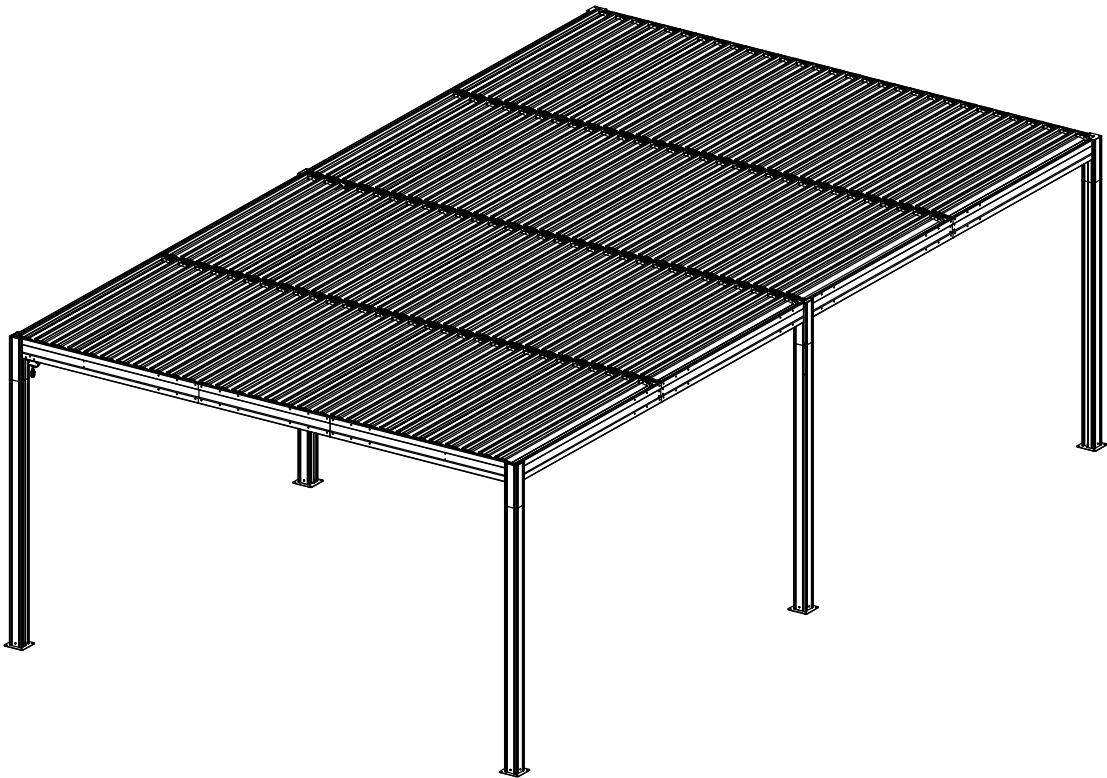

14' × 24' ALUMINUM
LOUVERED PERGOLA
ASSEMBLY MANUAL



MODEL#: LGCF1768

Missing part? Damaged? Contact us via email at

service@domioutdoorliving.com

www.domioutdoorliving.com

© Copyright 2024-2026 domioutdoorliving LLC. All Rights Reserved.

READ ALL INSTRUCTIONS BEFORE USE

Warning & Attention

-This gazebo is not a toy. Children are not allowed to assemble or disassemble. Please take care of children, do not let them play around when assemble or disassemble.

-Adults only for assemble or disassemble this product.

-This product is constructed with heavy duty frame, please do not lean or climb before it finish assembling.

-Even though our hardtop gazebo is sturdy, please do not stand under the gazebo during a lightning storm.

-DO NOT use this gazebo if any parts show signs of instability or damage.

-Maximum weight capacity is 1000 pounds.

-If moderate to heavy snow is forecast, open the lovers to avoid snow accumulating.



Four or more people are needed for assembly.



Find out and use the hex keys in the box.



One or more ladders are necessary.



A Phillips screwdriver is required.



Please wear protective glove before assembly.



Please don't fully tighten the screws prior to complete assembly.



Please wear a safety hat.



You may need prepare a drill.

14'x24' Louvered Pergola Dimension

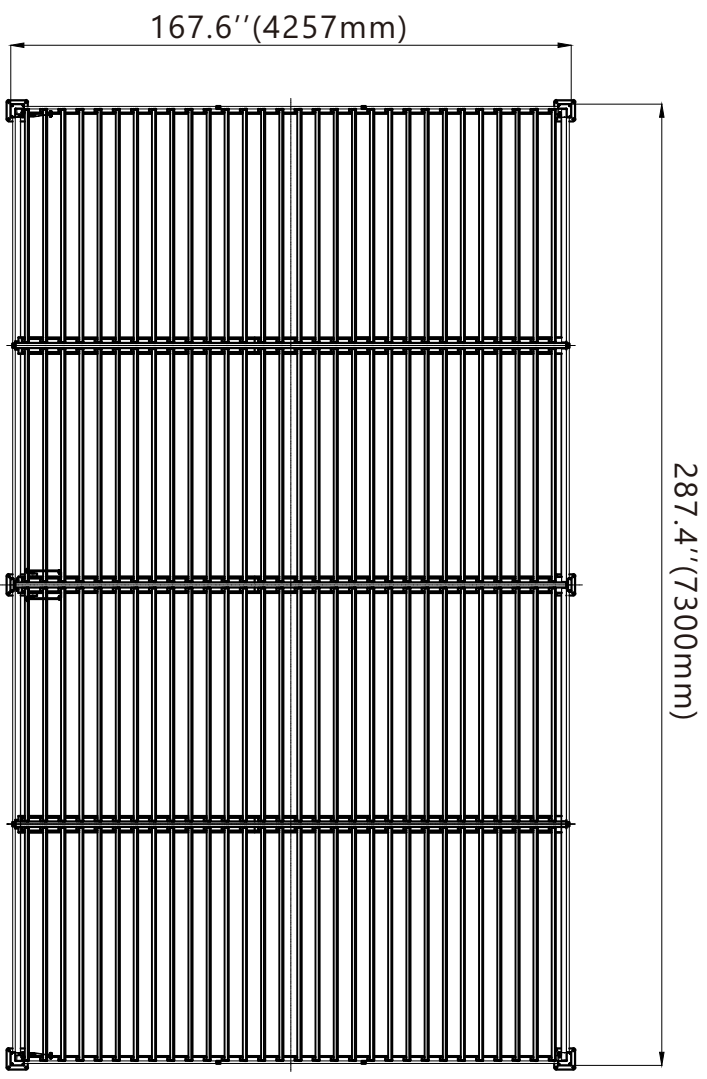
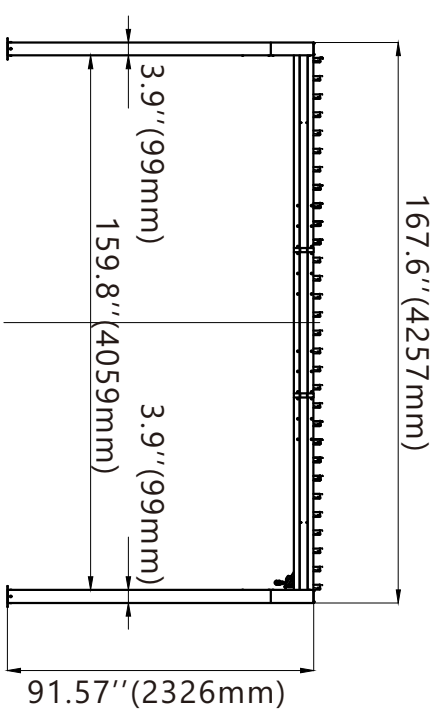
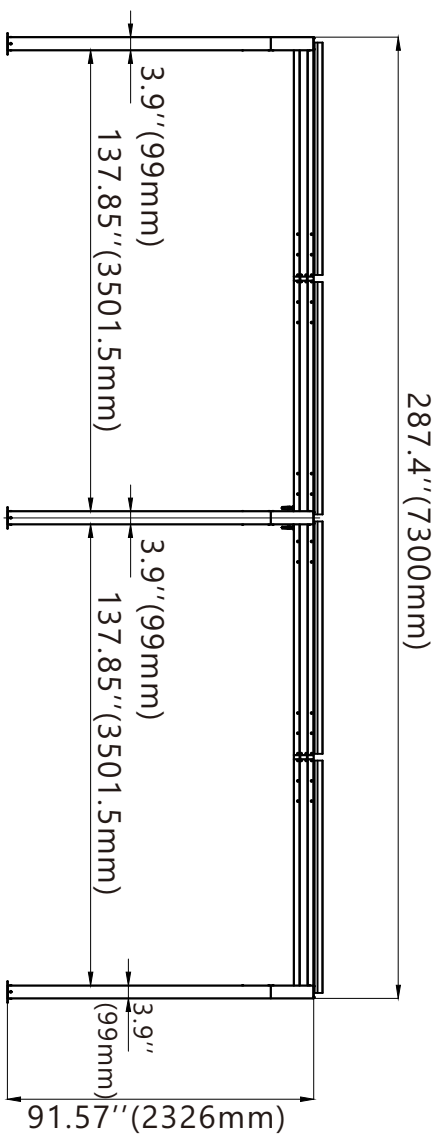

LGCF1768
14'x24'

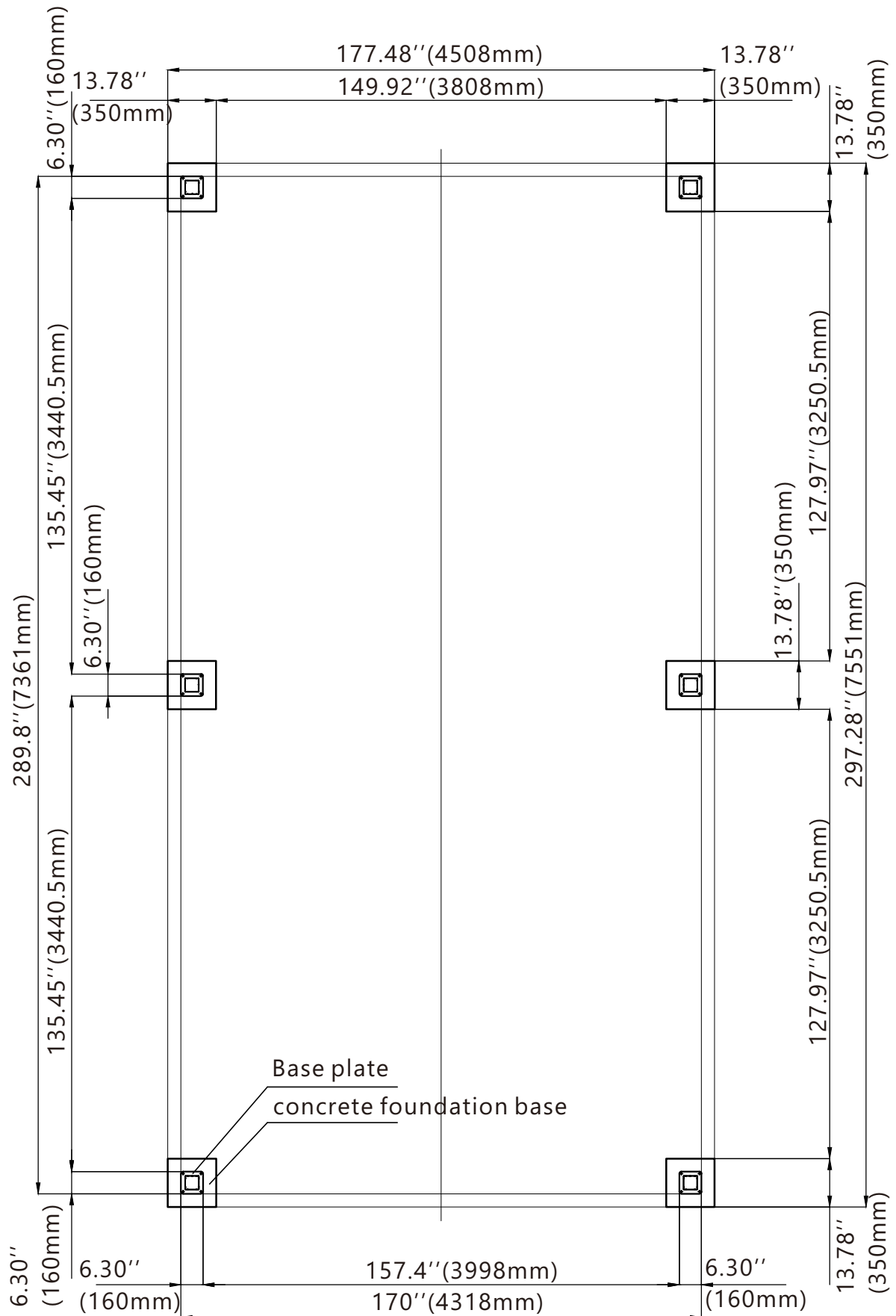

Foundation Mounting Drawing

1768 (14X24) – Foundation Mounting Base

This warranty does not cover products subject to inappropriate installation. Caution: The base plate of the pergola must be mounted on a concrete foundation with a thickness of over 3 inches using expansion bolts. DO NOT substitute expansion bolts with ordinary screws.

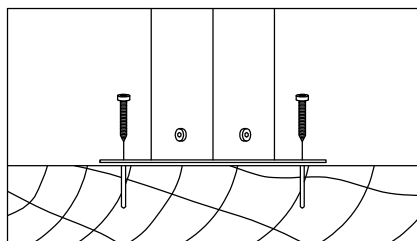
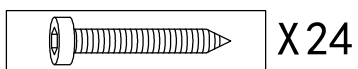



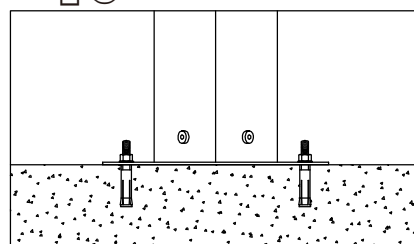
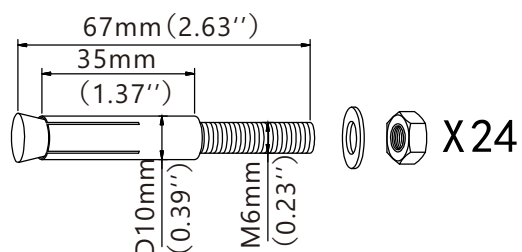
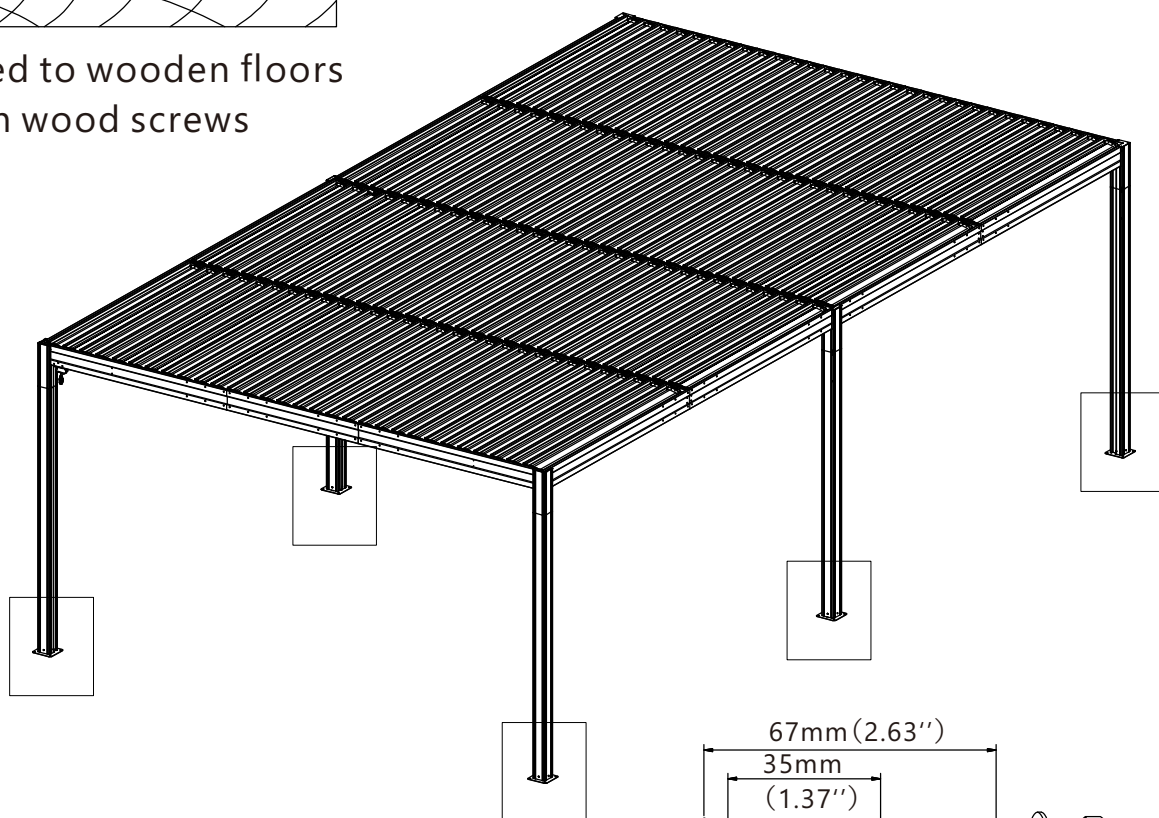



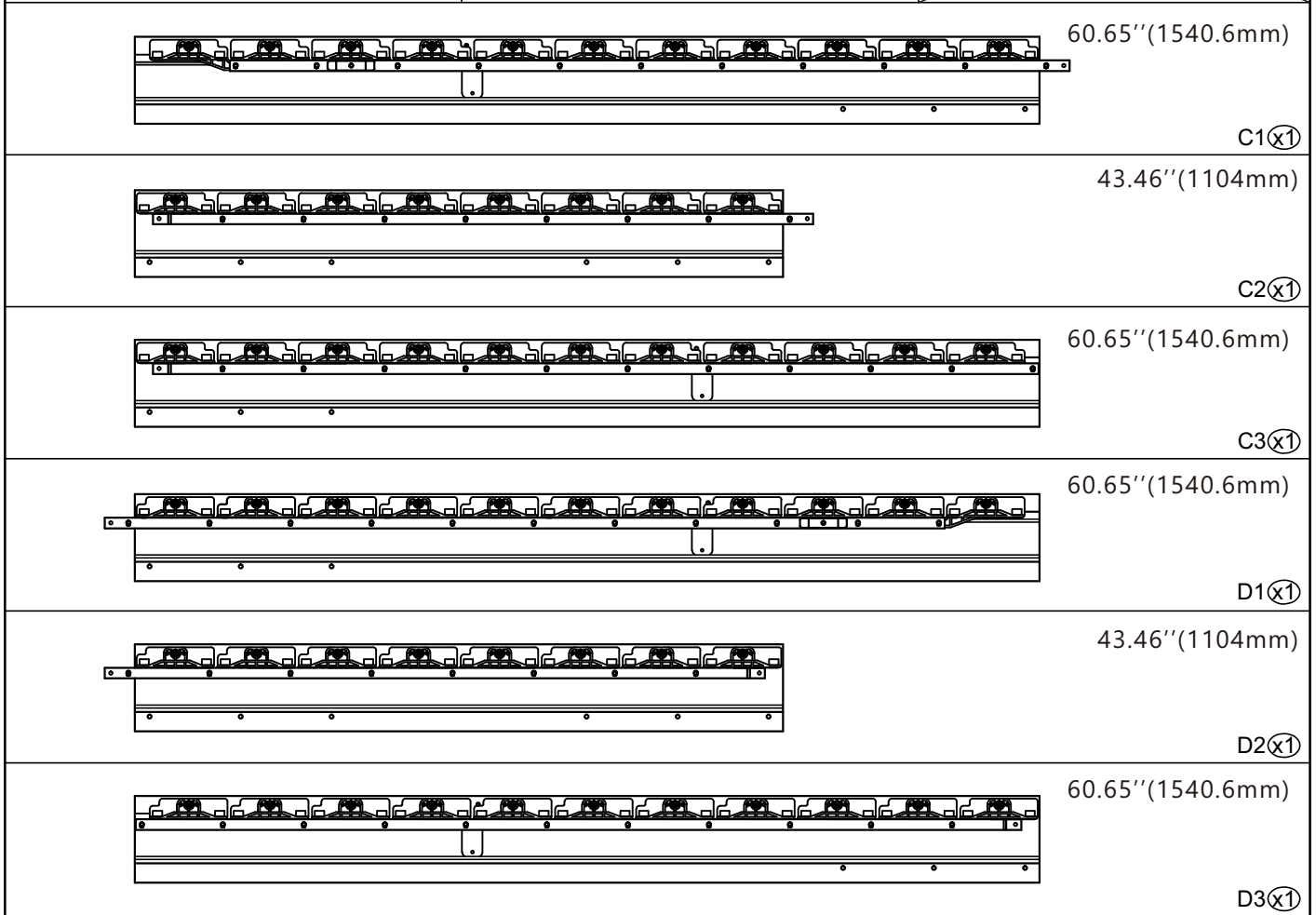
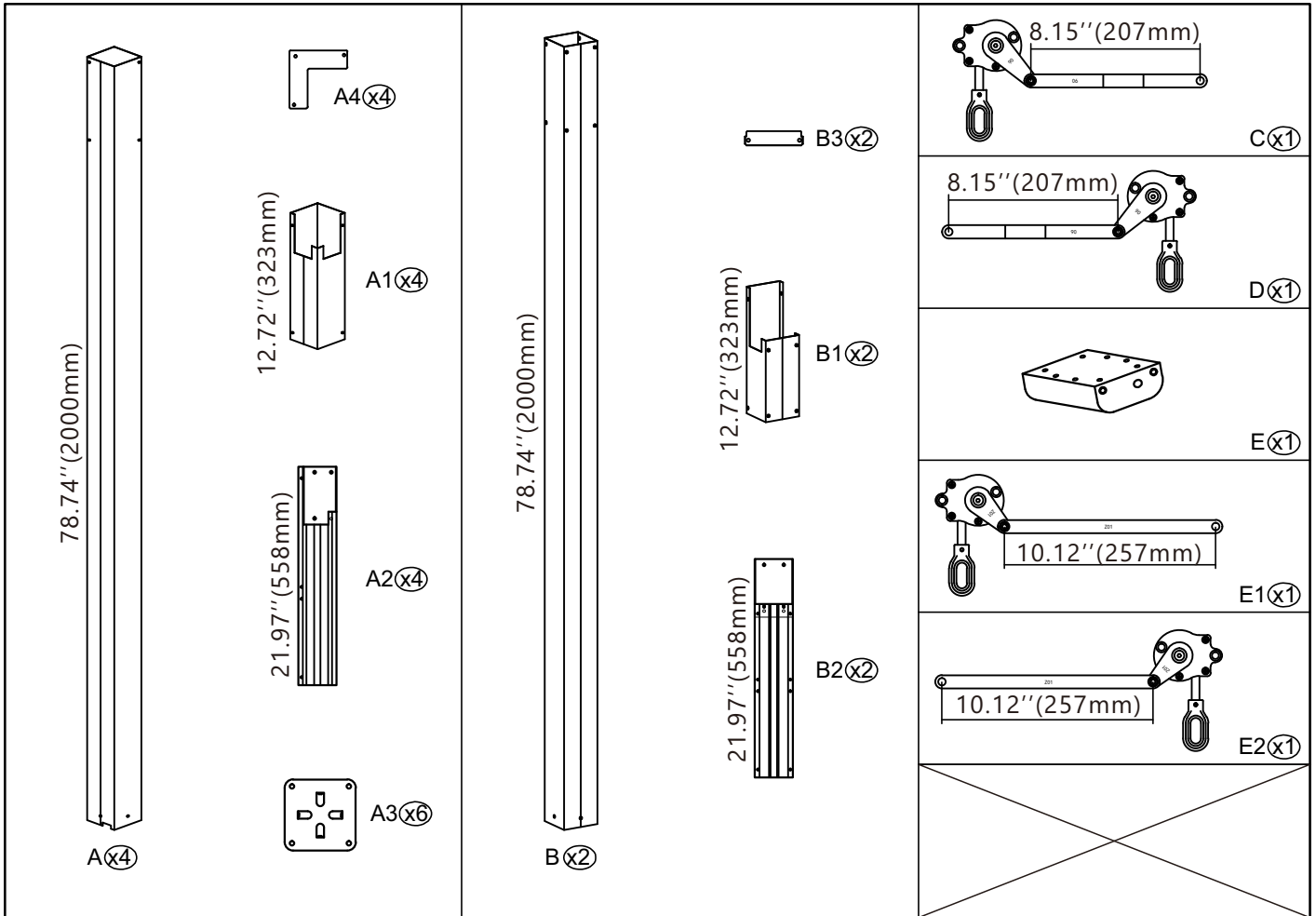

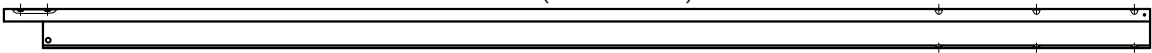

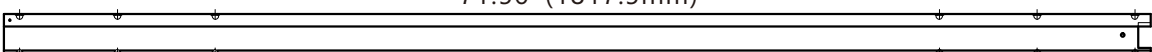

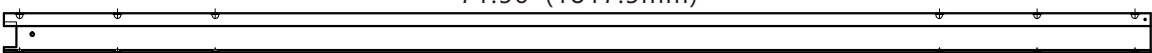

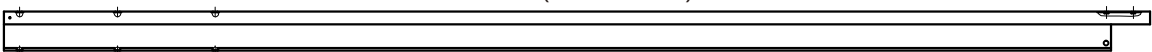

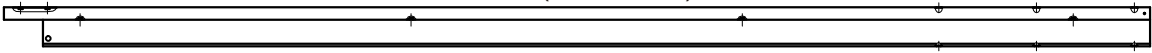
Fixed to wooden floors with wood screws

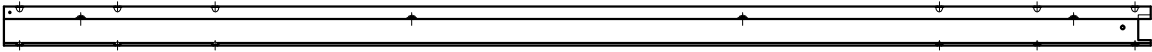
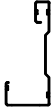
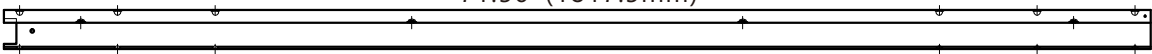

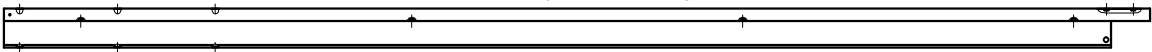
Fixed to concrete foundations with expansion tube screws

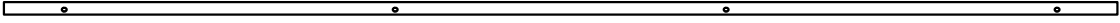
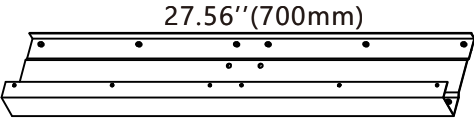
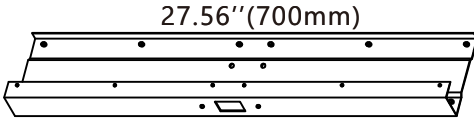
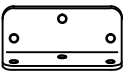
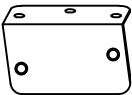
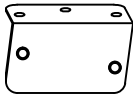
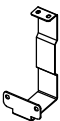
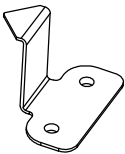

		F1(x1)
		F2(x1)
		F3(x1)
		F4(x1)
		G1(x1)
		G2(x1)
		G3(x1)
		G4(x1)
		H(x4)
		J(x8) J1(x2)
		 Worm Gear Bracket (right)
K(x2)	Worm Gear Bracket K1(x1)	K2(x1)
		
L(x8)	Universal Corner Post Insert(4pcs) L1(x4)	U(x12)

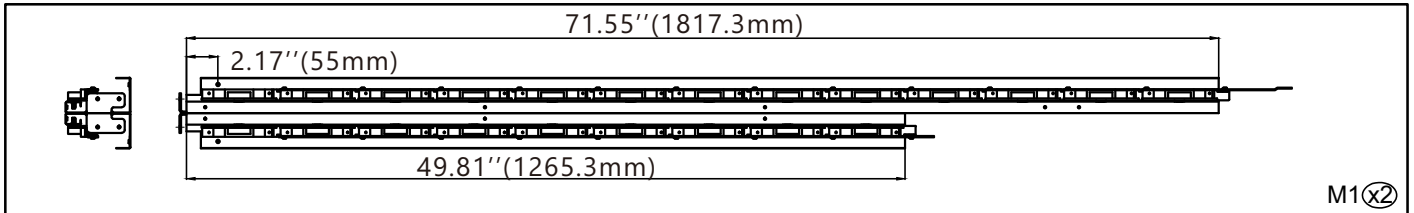

M1(x2)

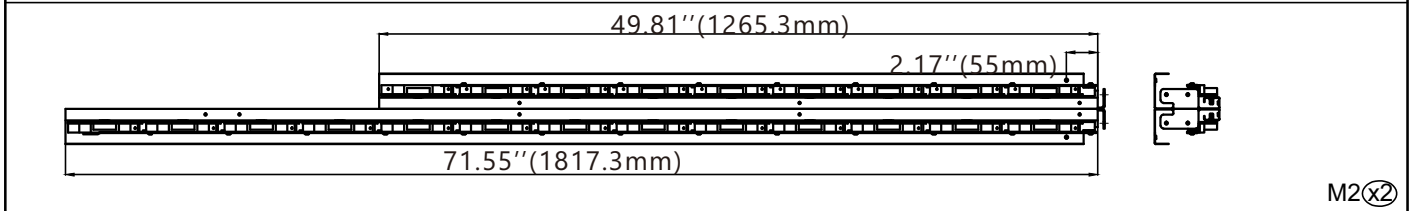

M2(x2)

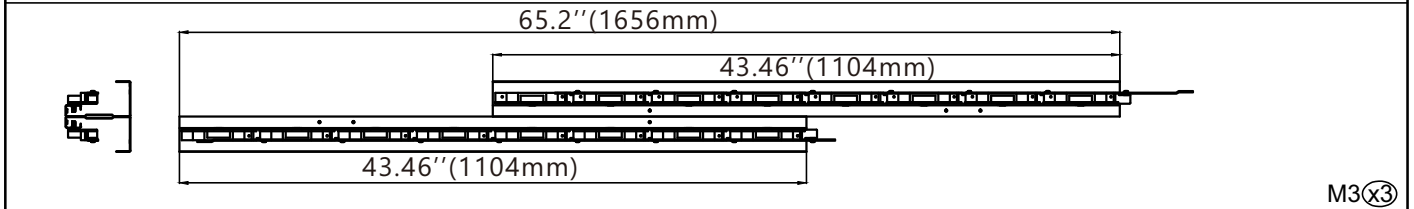

M3(x3)

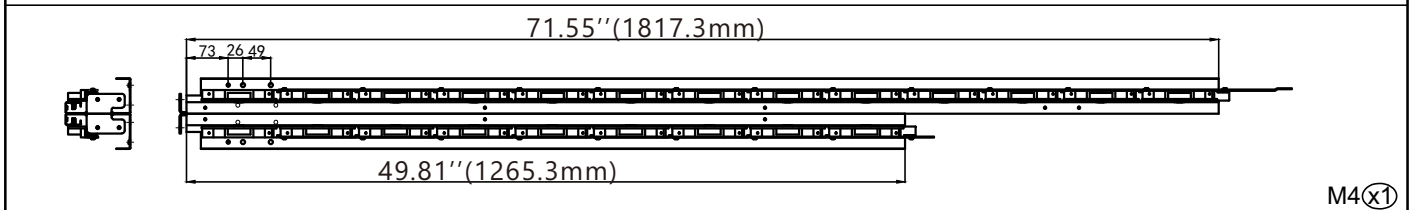

M4(x1)

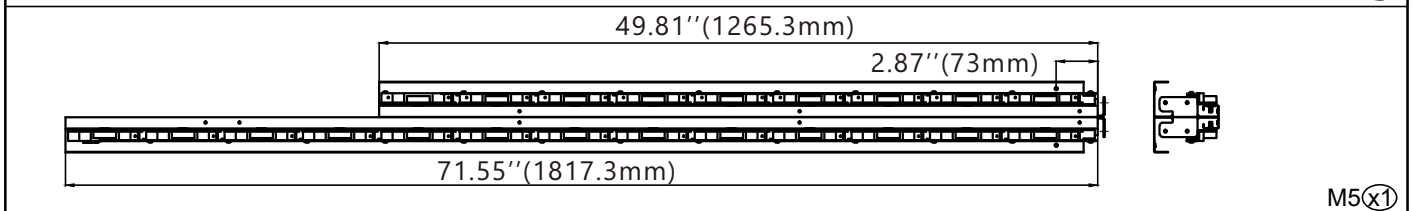

M5(x1)

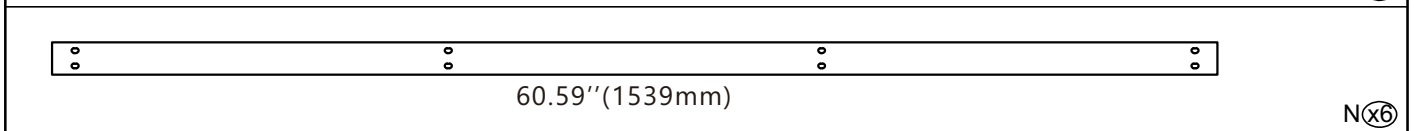

N(x6)

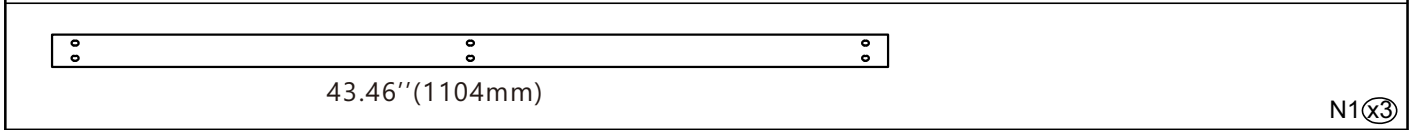

N1(x3)

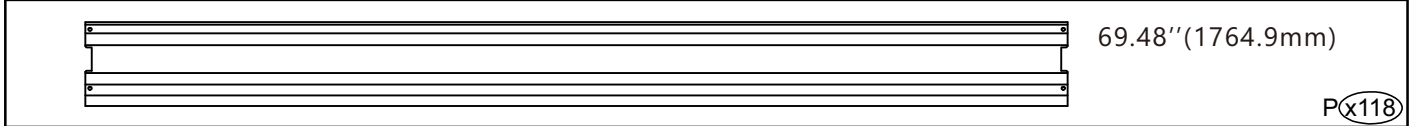

P(x118)

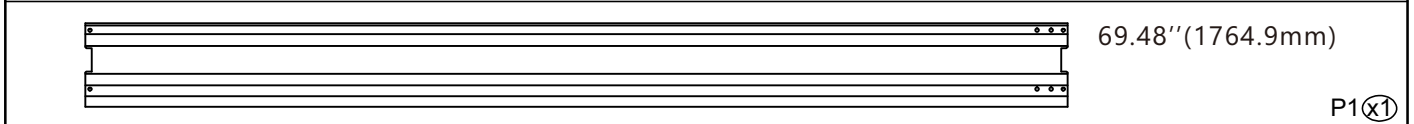



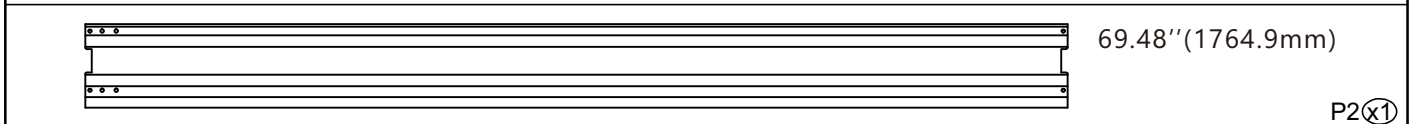



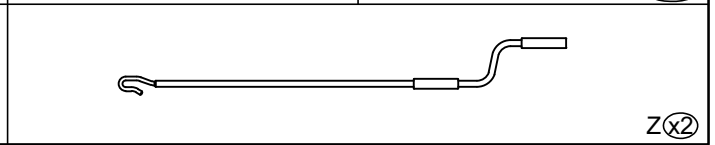
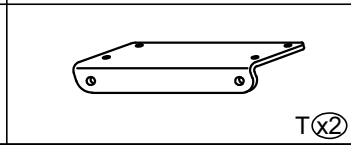
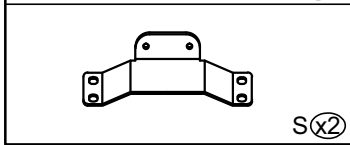
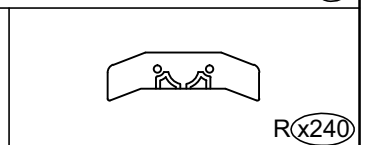
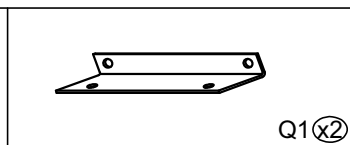
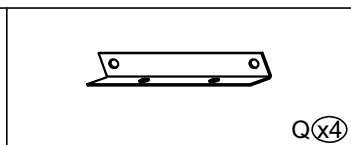
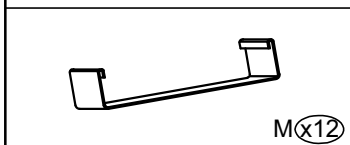



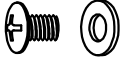

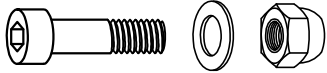
P1(x1)

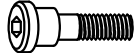

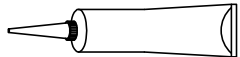
P2(x1)

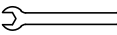
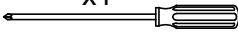

	M6x12	1# x328		
	M5x8	2# x162		
	M6x8	3# x16		
	ST4.2x16	4# x20		
	M8x32	5# x8		
	M6	6# x4		
	Plastic gaskets	7# x4		
		8# x4		
	4x6	9# x496		
	ST3.5x16	10# x480		
	Silicone sealant	11# x5		
 S6 x1	 S4 x1	 S10 x1	 S13 x1	 x1

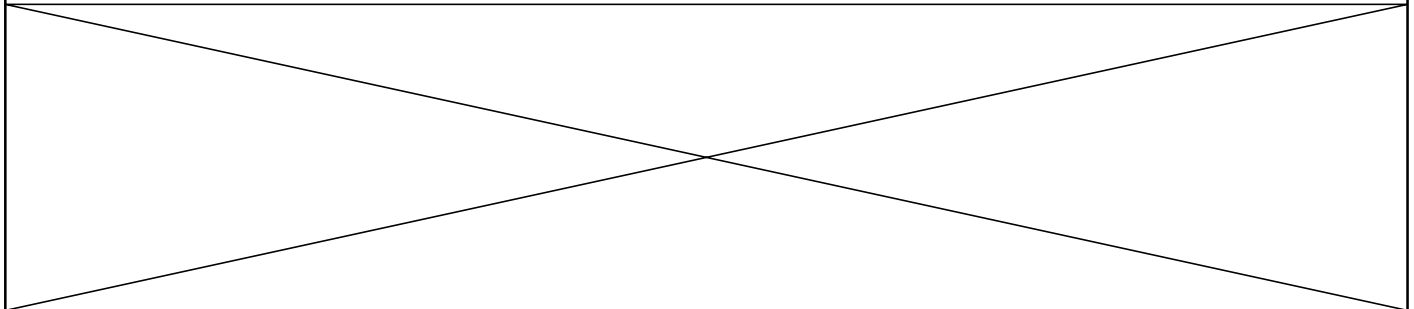

Assemble the base:

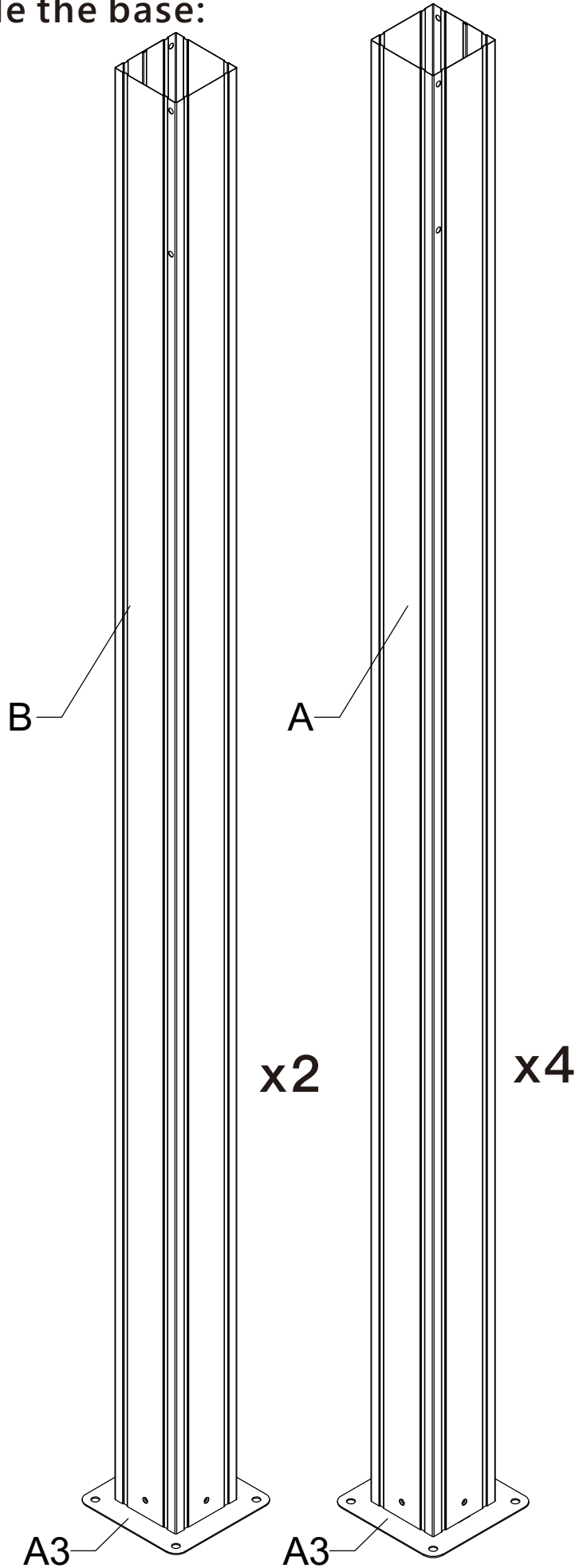
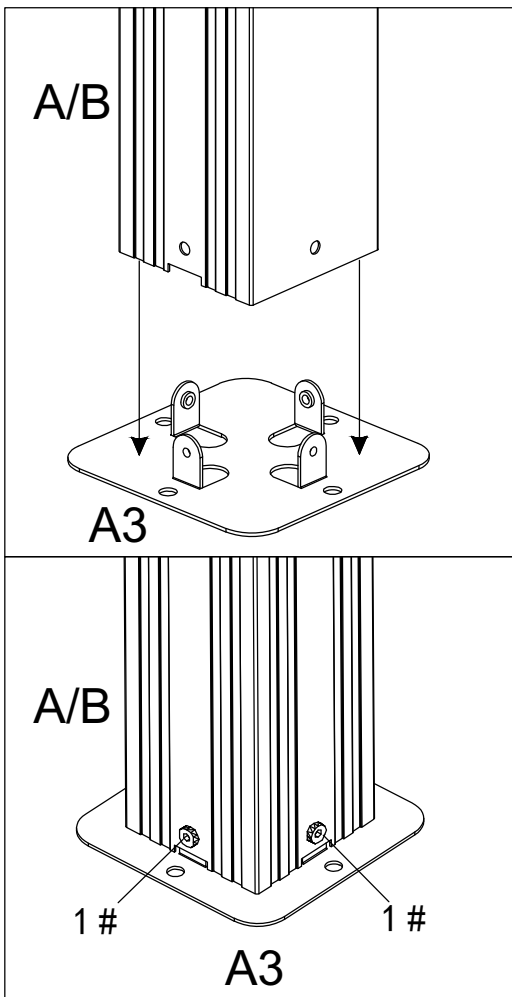
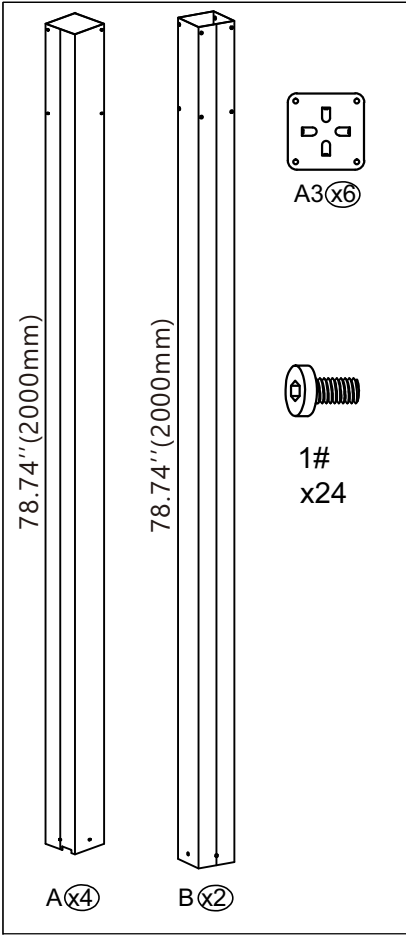



C1(x1)



C2(x1)



C3(x1)

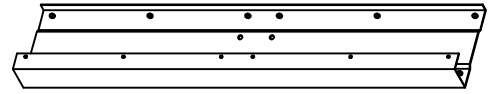

J(x2)

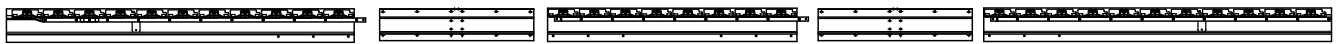

C1

J

C2

J

C3

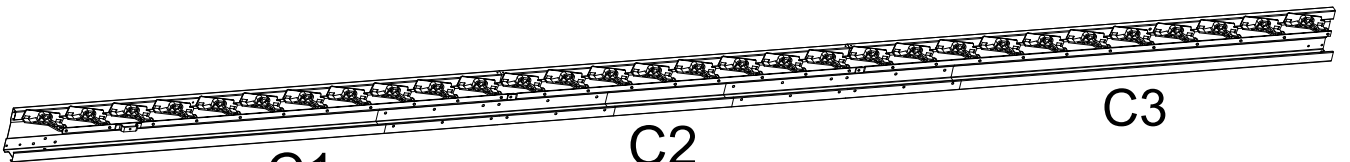

C1

C2

C3

Insert Part #J into Part #C1 and Part #C2,
also insert Part #J into Part #C2 and Part #C3, align the holes.

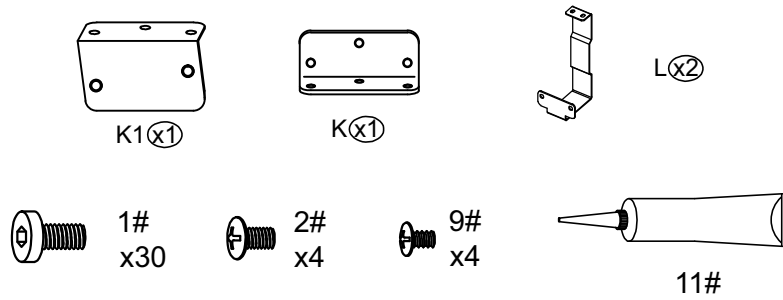

Use 12 bolts #1 to secure Part #J with Part #C1 and Part #C2 (from outside). Repeat the above step to install Part #J between Part #C2 and Part #C3.

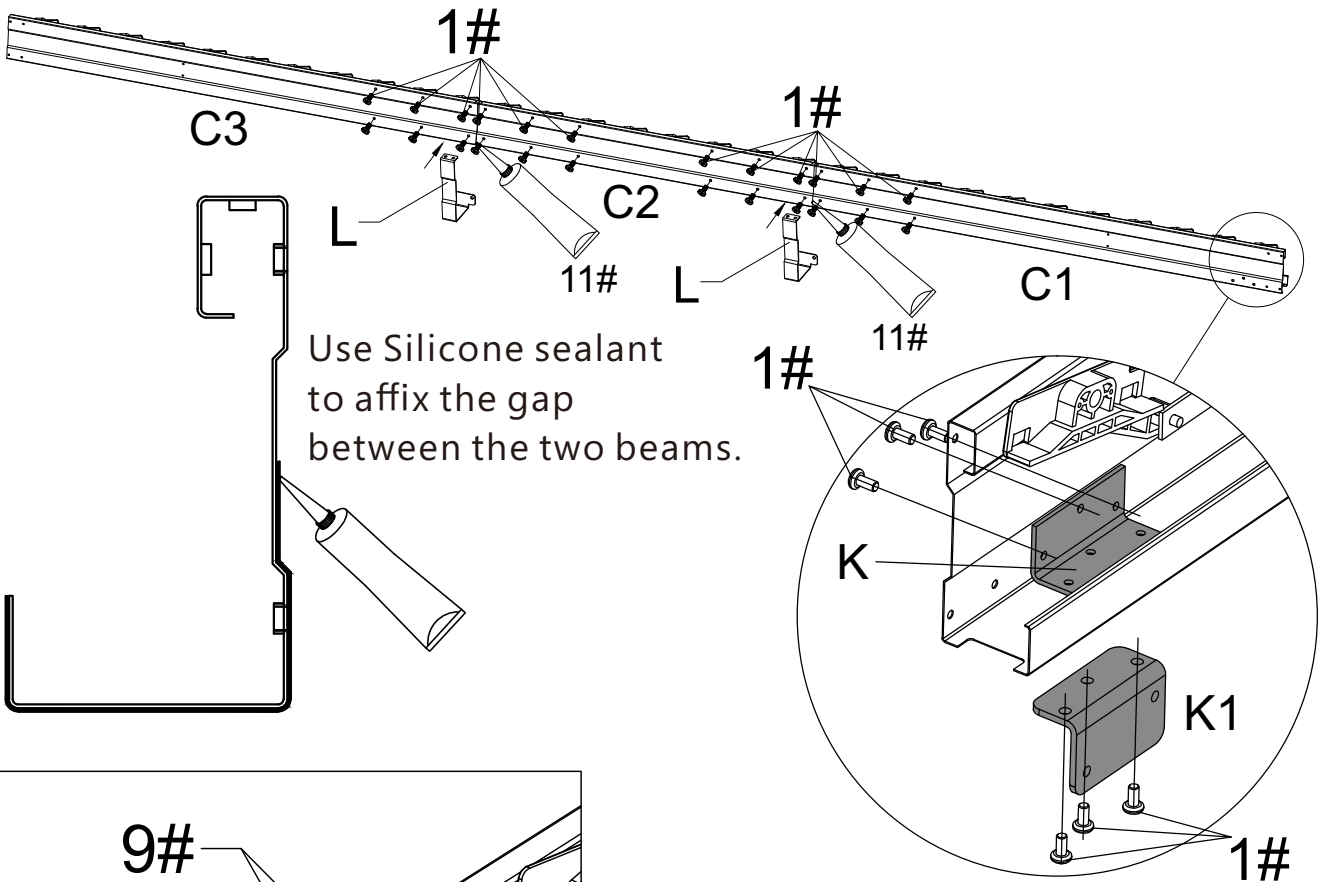

Use 3 bolts #1 to secure part #K, align the holes, and 3 bolts #1 to secure part #K1 to the beam with part #K.

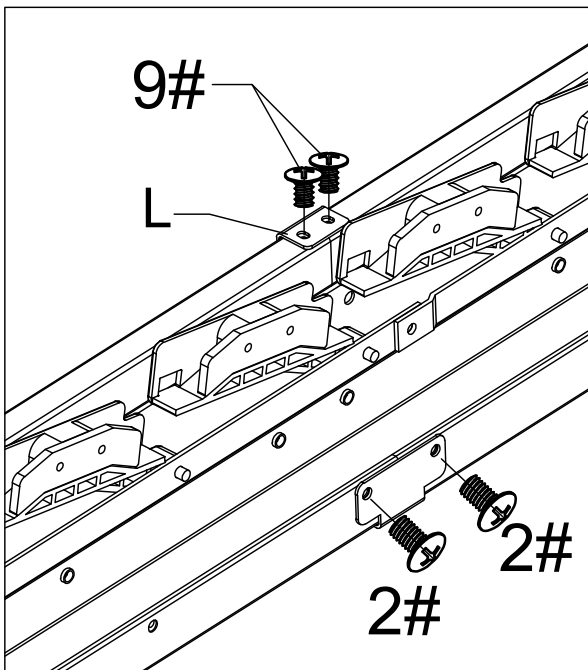

Cover the gap with Gap Cover #L, secure with 2 bolts #9 and 2 bolts #2 as shown, Repeat the above step to install Gap Cover #L over another beam gap.

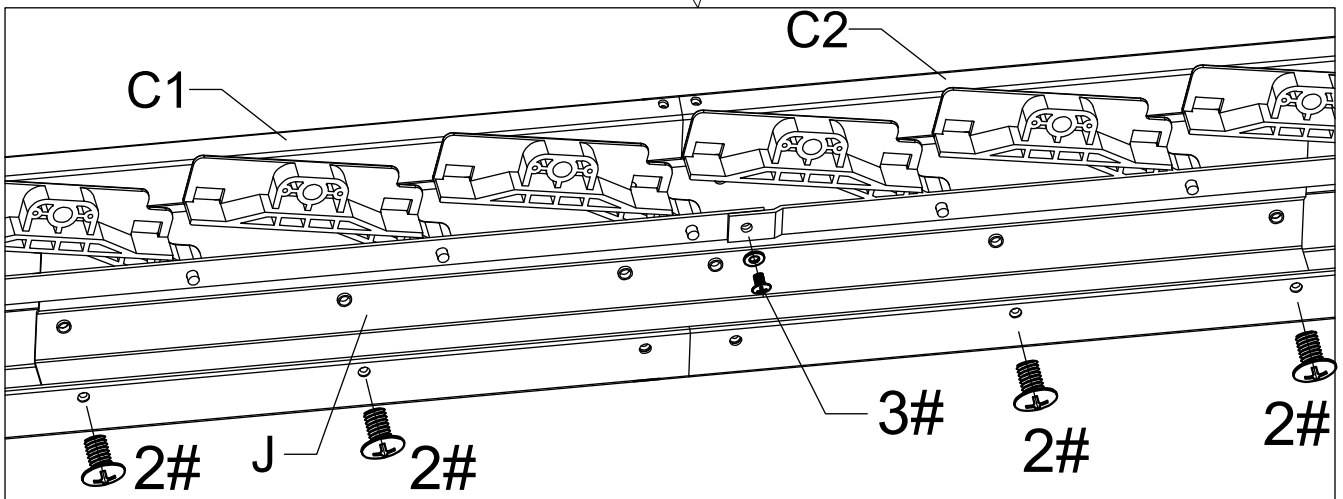
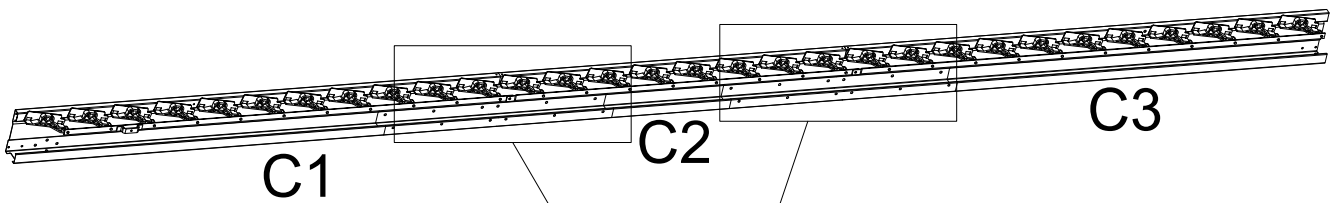
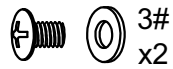
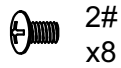

Align the holes, use 4 bolts #2 to secure Part #J with Part #C1 and Part #C2, use bolts and washer #3 to secure the linkage rod. Repeat above steps to secure Part #J with Part #C2 and Part #C3,

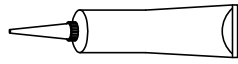

11#

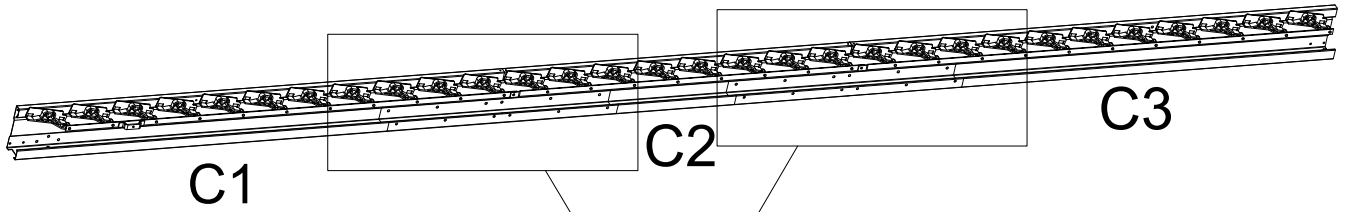

Inside View

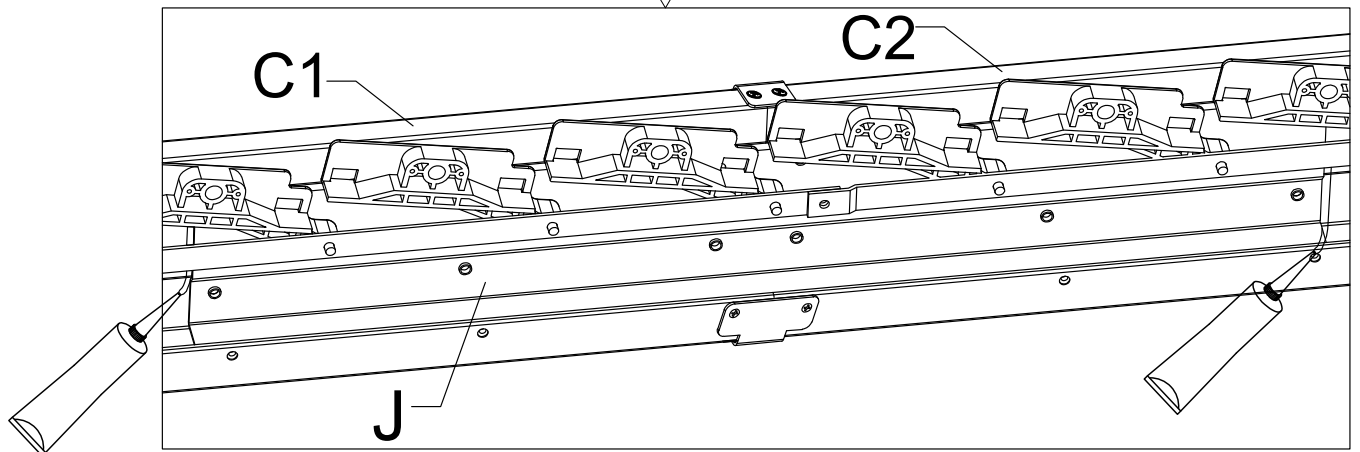

Seal both ends of the beam connector #J with sealant.

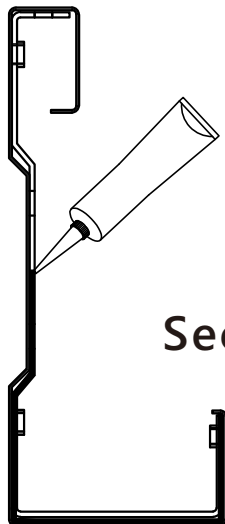

Section View

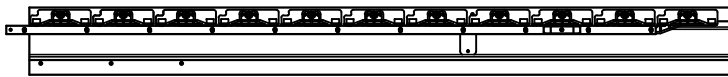

D1(x1)



D2(x1)

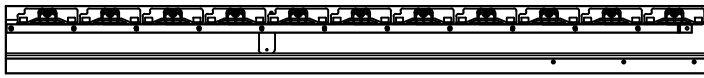

D3(x1)

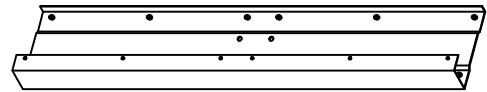

J(x2)

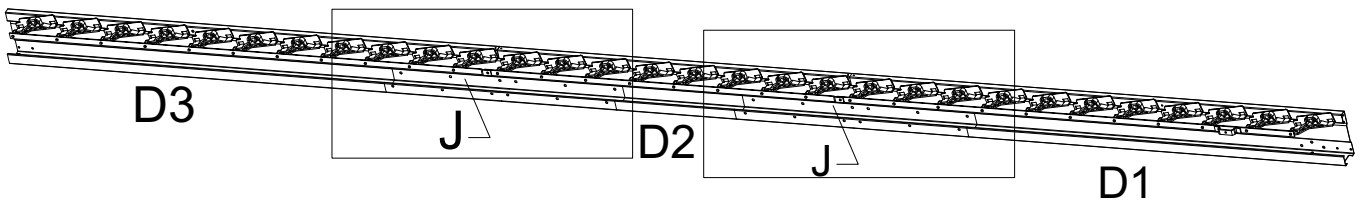
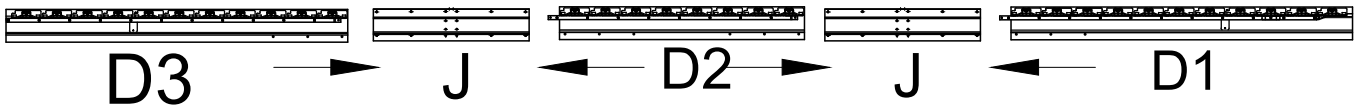

Insert Part #J into Part #D1 and Part #D2,
also insert Part #J into Part #D2 and Part #D3, align the holes.

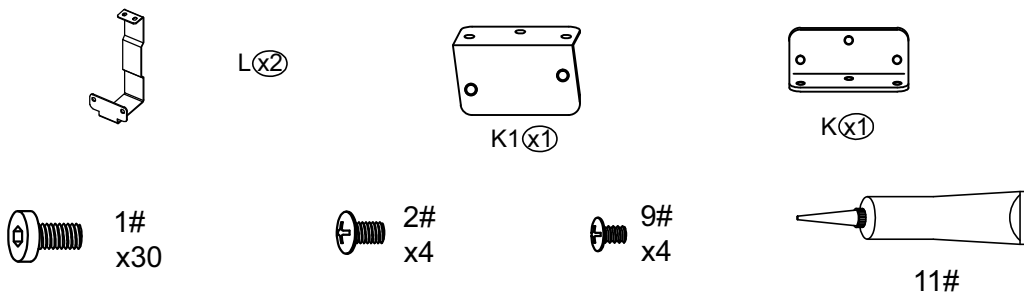

Use 12 bolts #1 to secure Part #J with Part #D1 and Part #D2(from outside). Repeat the above step to install Part #J between Part #D2 and Part #D3.

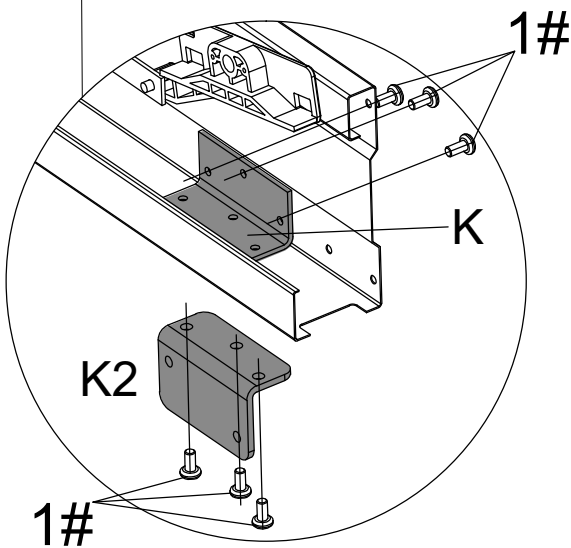
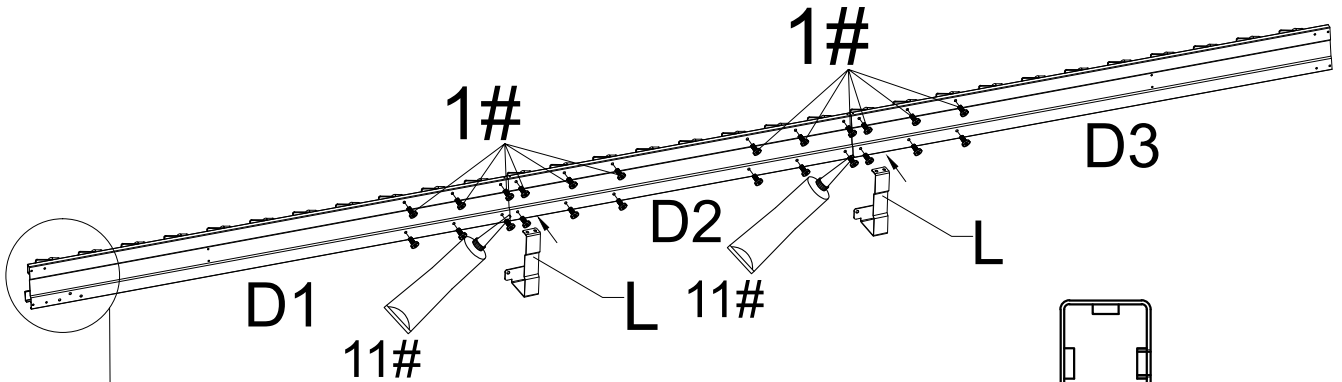

Use 3 bolts #1 to secure part #K, align the holes, and 3 bolts #1 to secure part #K2 to the beam with part #K.

Cover the gap with Gap Cover #L, secure with 2 bolts #9 and 2 bolts #2 as shown. Repeat the above step to install Gap Cover #L over another beam gap.

Use Silicone sealant to affix the gap between the two beams.

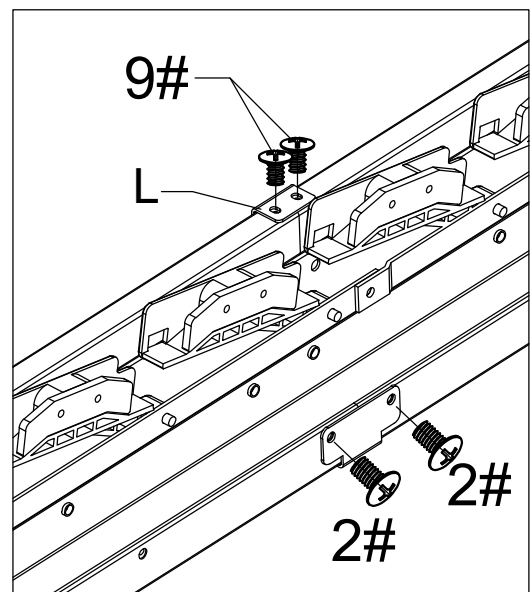

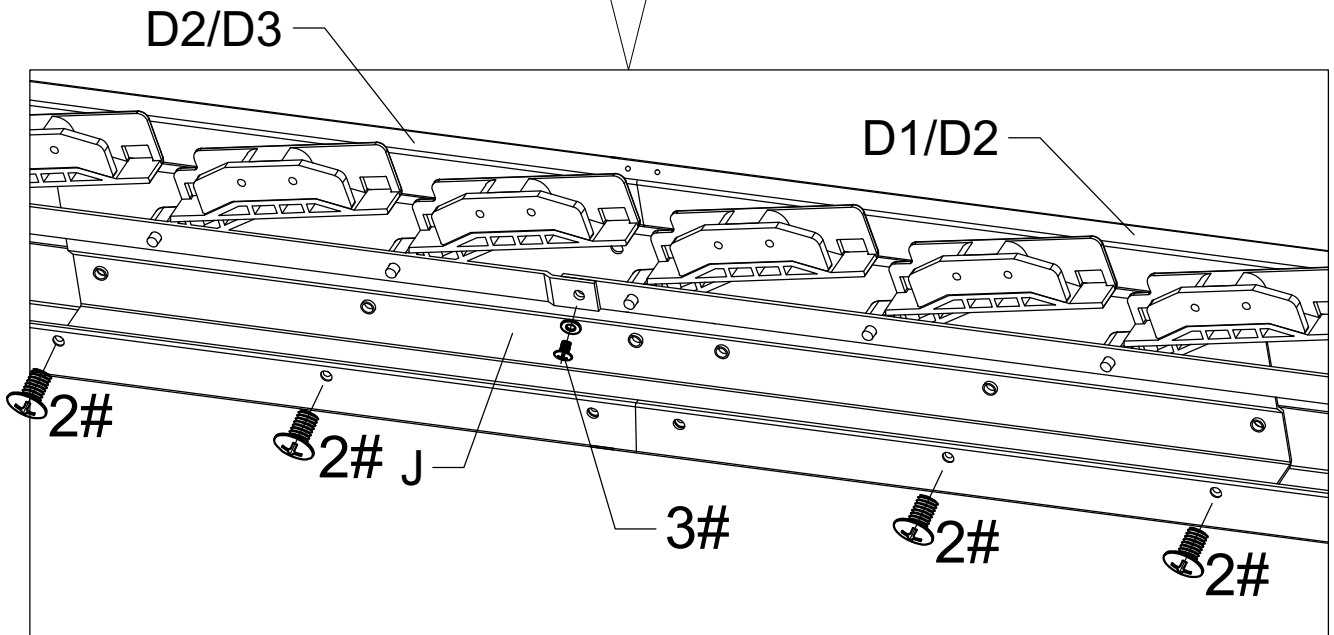
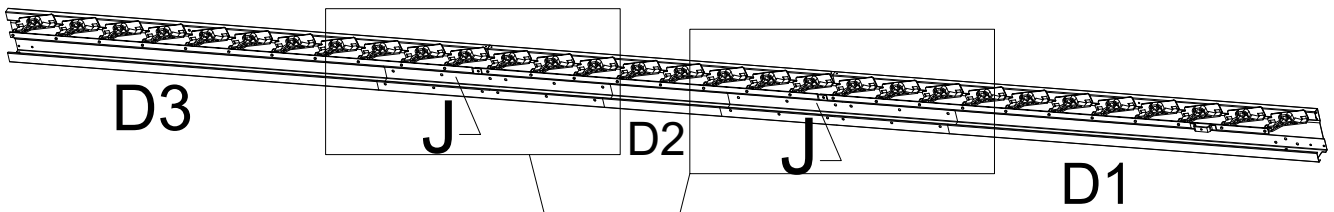
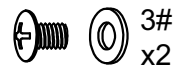
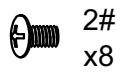

Align the holes, use 4 bolts #2 to secure Part #J with Part #D1 and Part #D2, use bolts and washer #3 to secure the linkage rod. Repeat the above steps to secure Part #J with Part #D2 and Part #D3 .

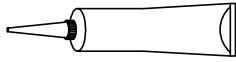

11#

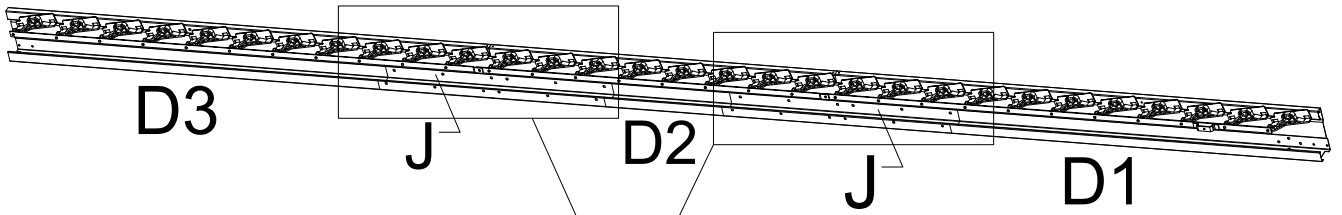

D3

J

D2

J

D1

Inside View

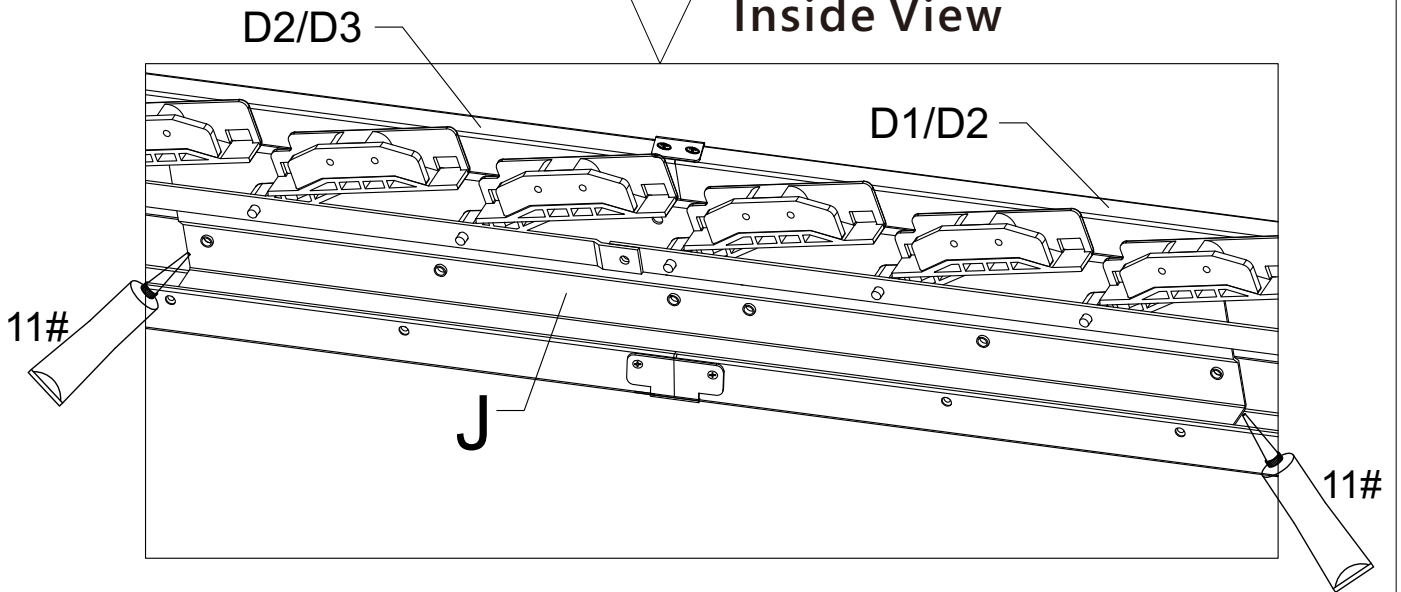

D2/D3

D1/D2

11#

J

11#

Seal both ends of the beam connector #J with sealant.

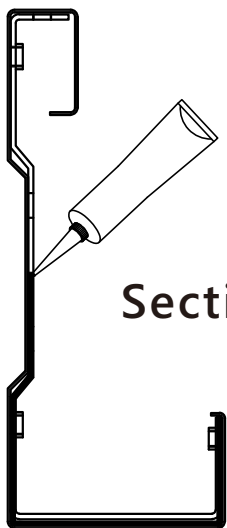

Section View

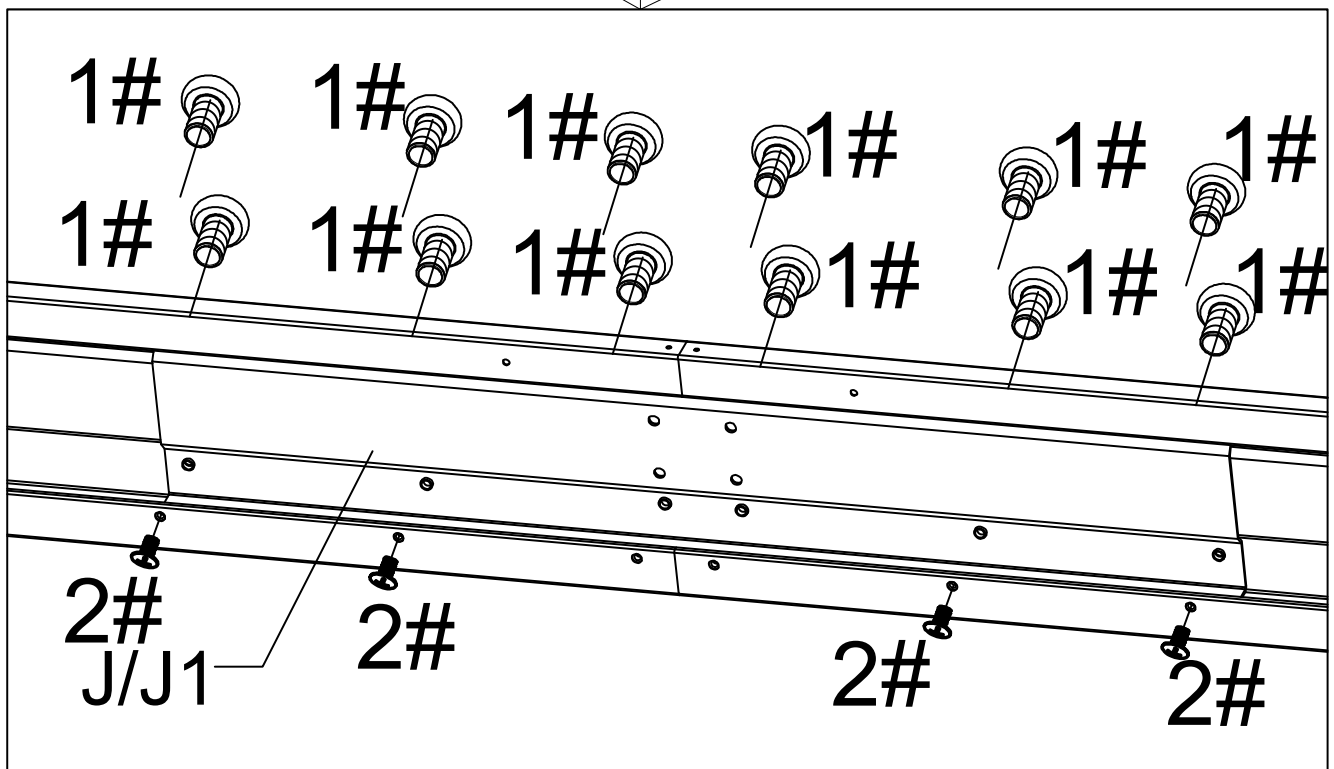
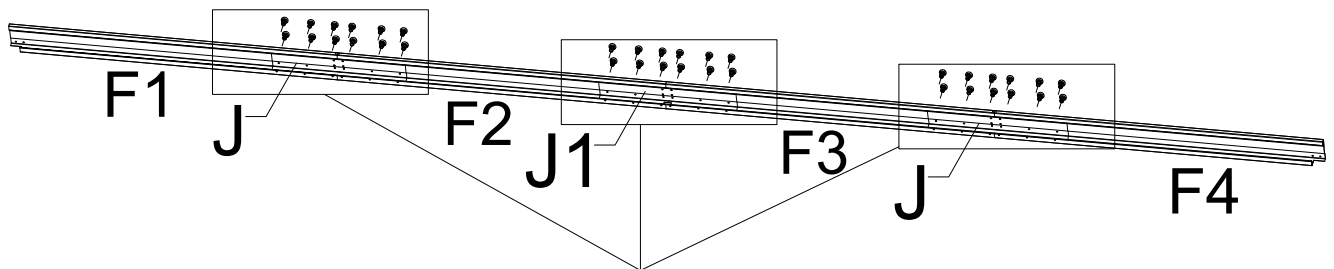
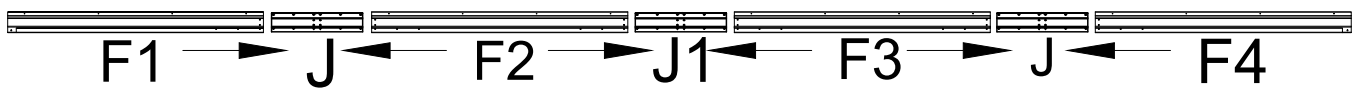
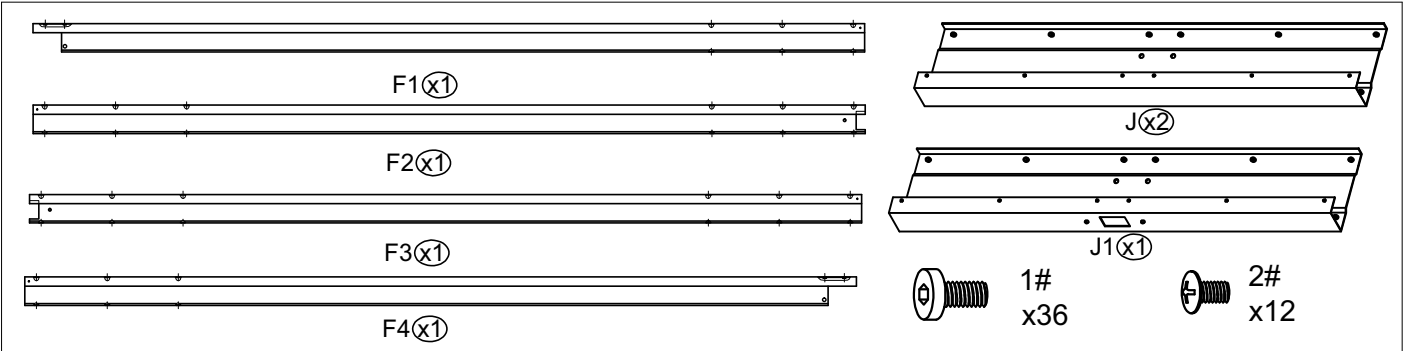

Insert Part #J between Part #F1 and Part #F2, then align all mounting holes. Secure Part #J to Part #F1 and Part #F2 from the inside with 4 bolts #2. Further secure Part #J to Part #F1 and Part #F2 from the outside with 12 bolts #1. Repeat above procedures to assemble Part #J1 between Part #F2 and Part #F3, and Part #J between Part #F3 and Part #F4.

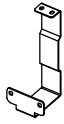

L x2



9#
x4

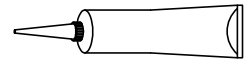

11#

Use Silicone sealant to affix the gap between the beams.

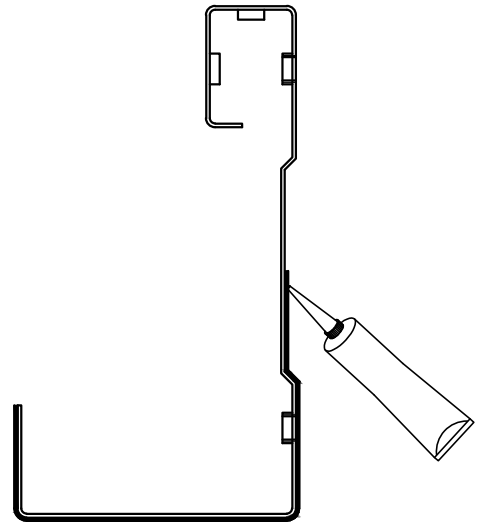
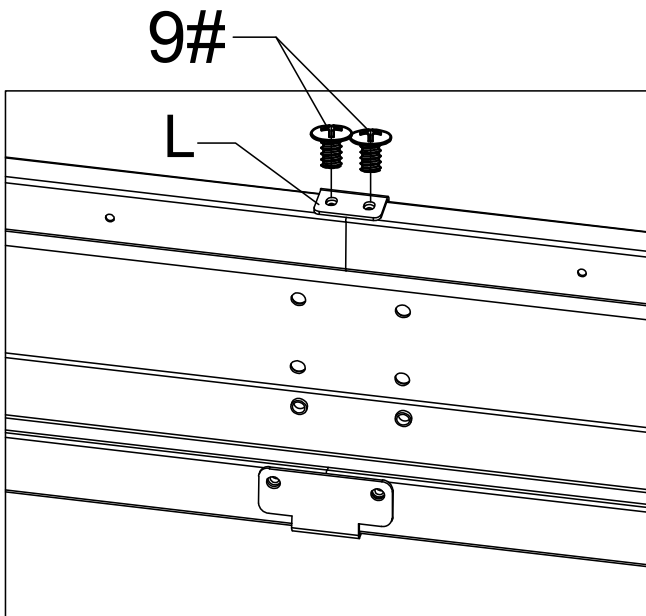
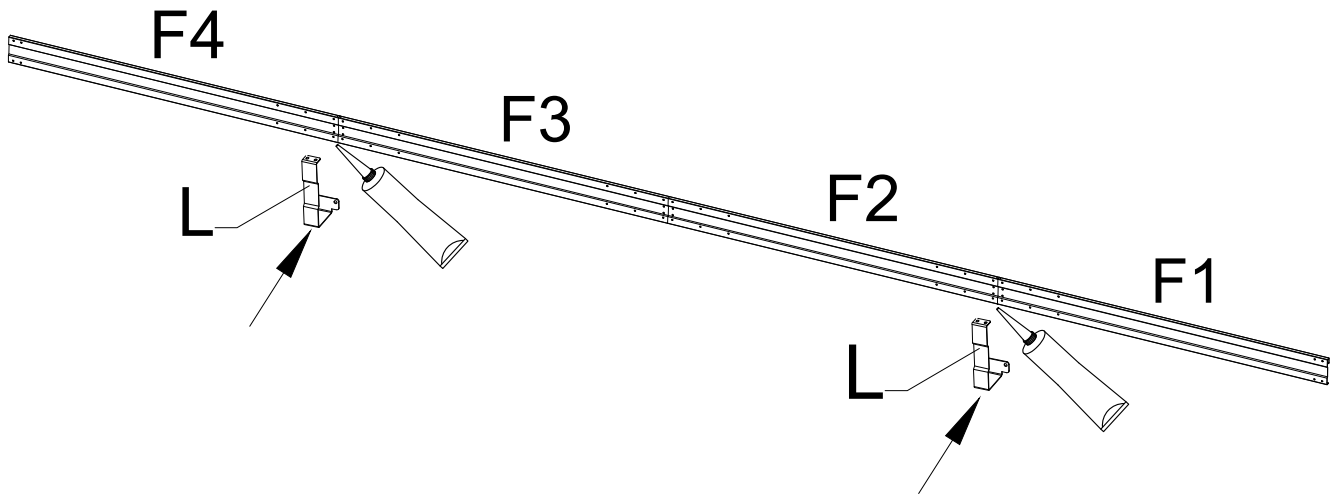

Cover the gap with Gap Cover #L, secure with 2 bolts #9.

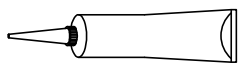

11#

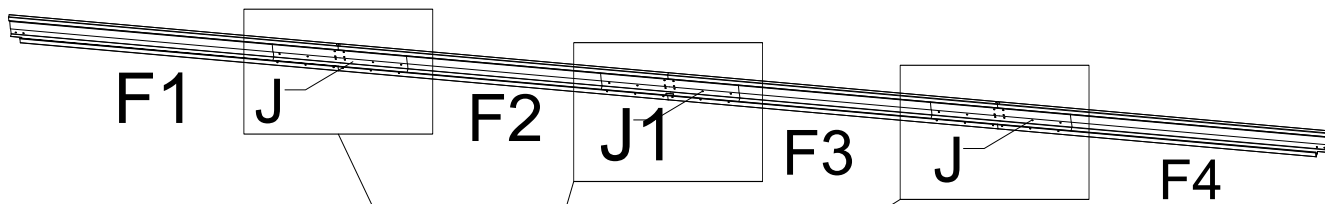

Inside View

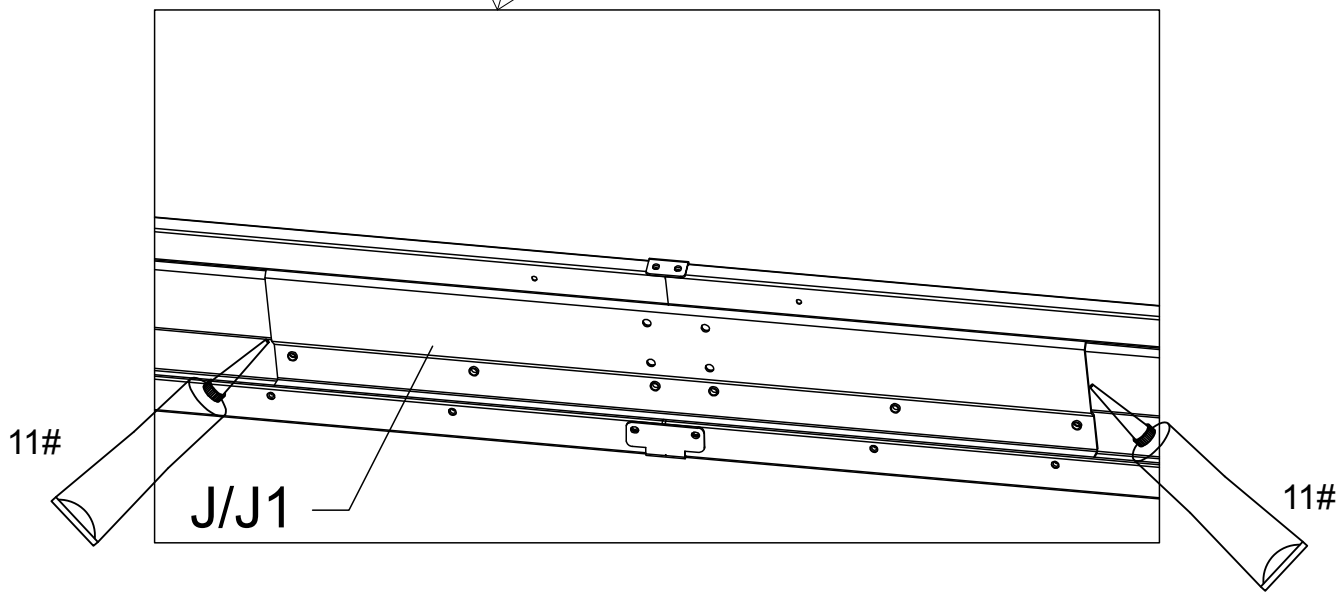

Seal both ends of the beam connector J/J1 with sealant.

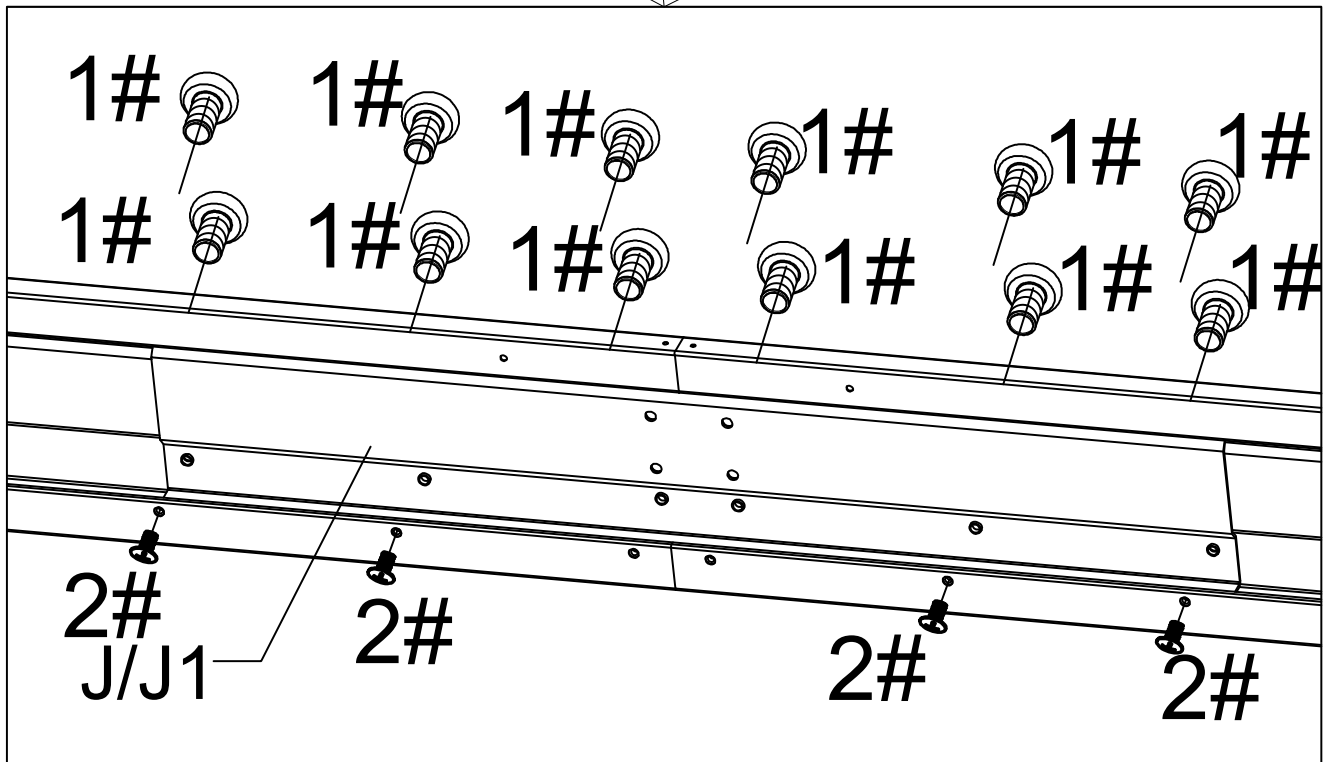
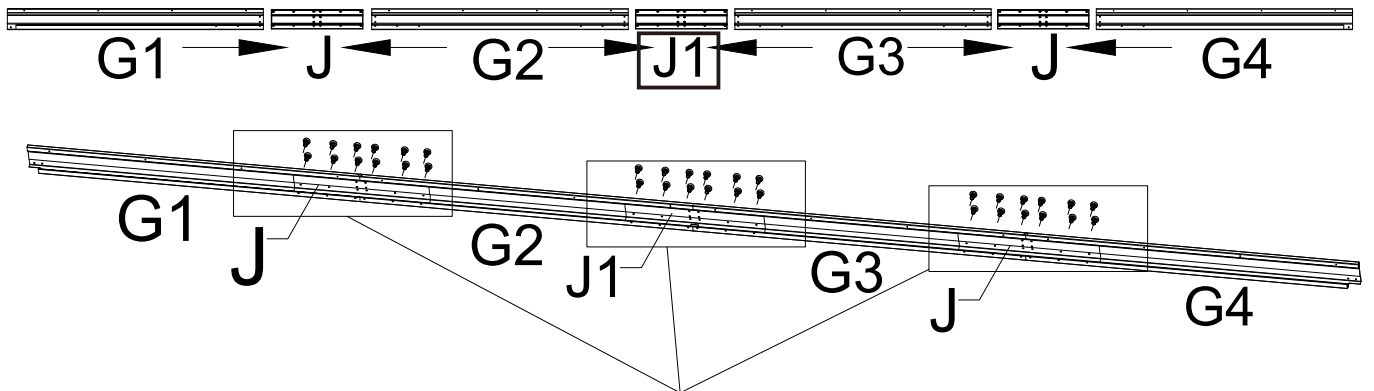
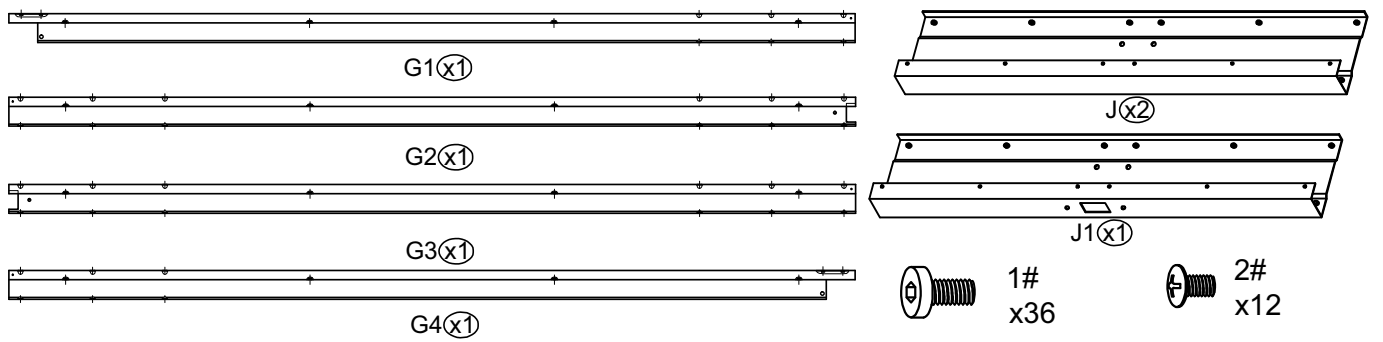

Insert Part #J between Part #G1 and Part #G2, then align all mounting holes. Secure Part #J to Part #G1 and Part #G2 from the inside with 4 bolts #2. Further secure Part #J to Part #G1 and Part #G2 from the outside with 12 bolts #1. Repeat above procedures to assemble Part #J1 between Part #G2 and #G3, and Part #J between Part #G3 and #G4.

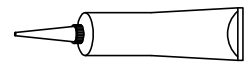
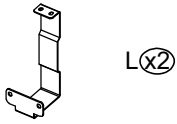

11#

Use Silicone sealant to affix the gap between the beams.

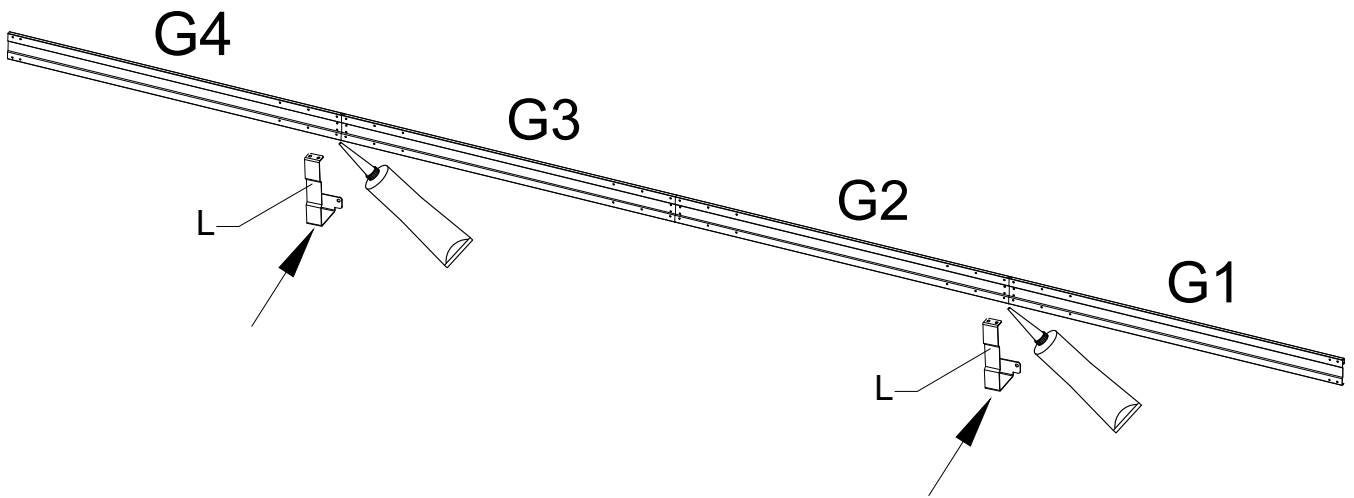

Cover the gap with Gap Cover #L, secure with bolts #9.

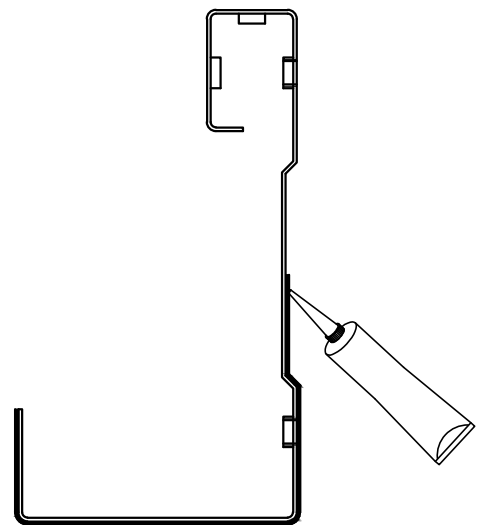
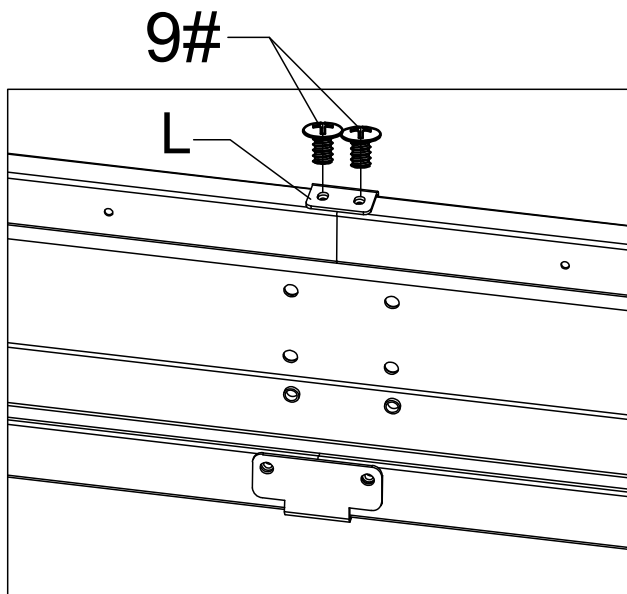

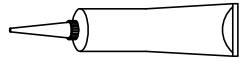

11#

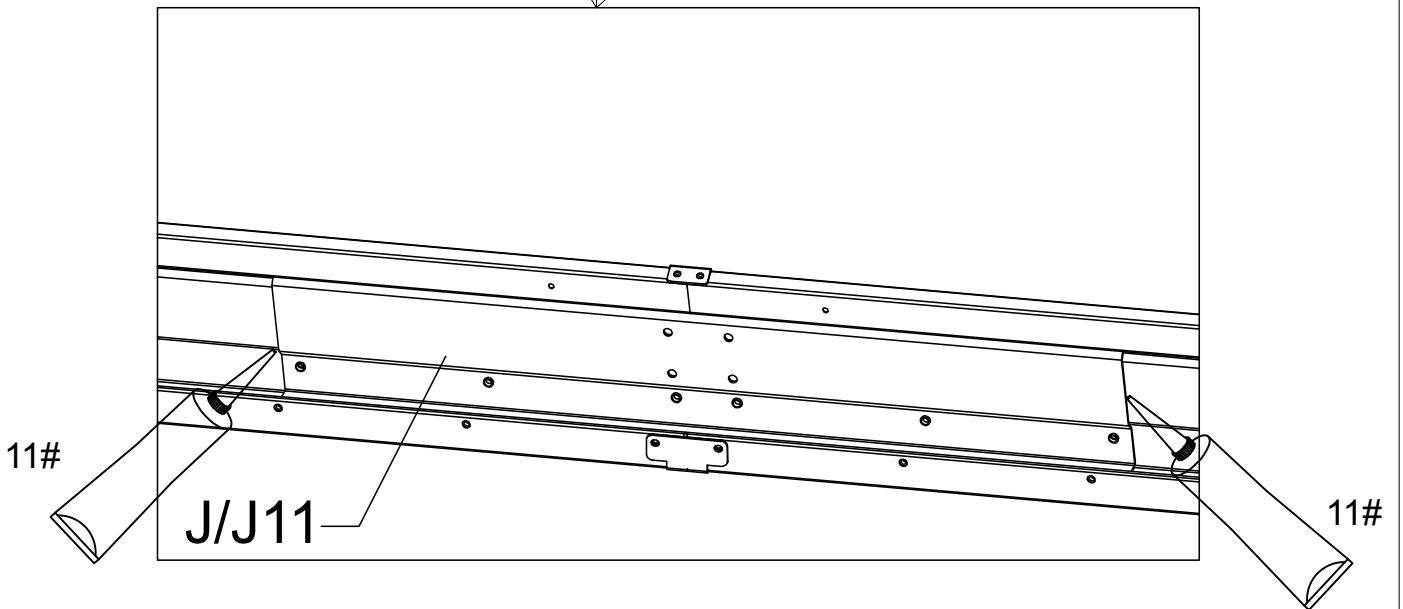
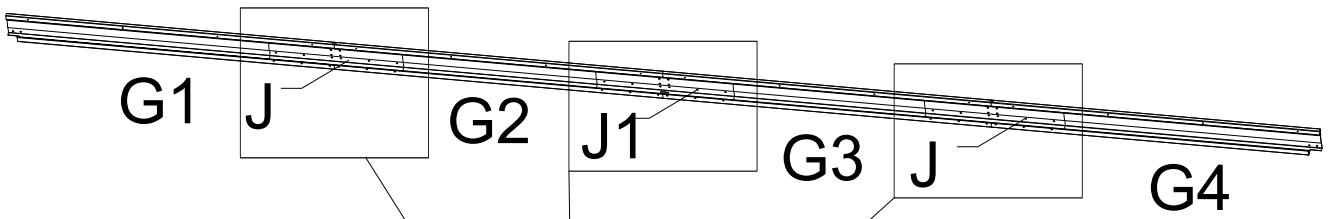

Seal both ends of the beam connector J/J1 with sealant.

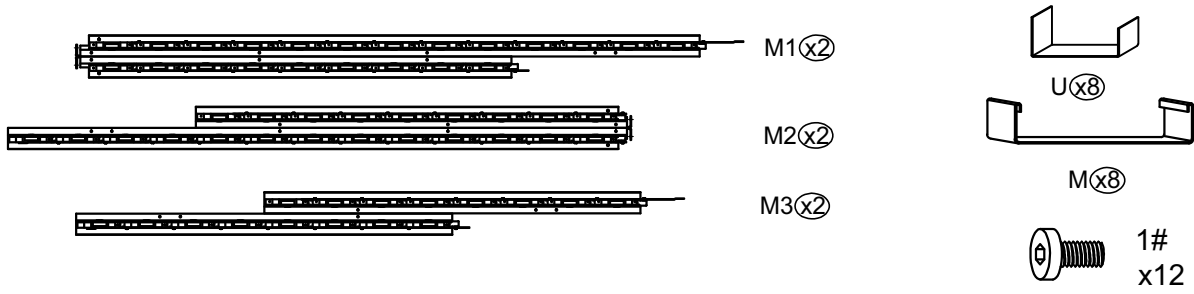

Top View

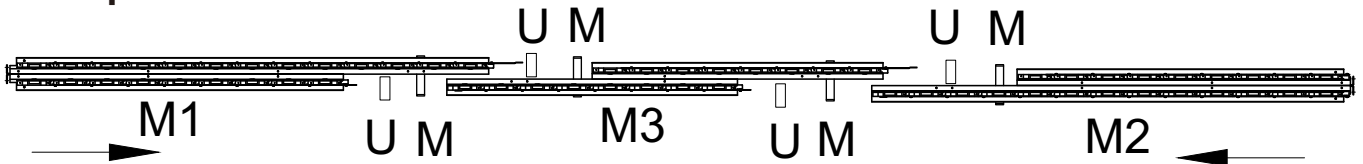

Insert U-shaped joint cover #U in each groove.
 Snap U-shaped joint cover #M from the bottom, then connect the two beams (M1 & M3, M3 & M2).

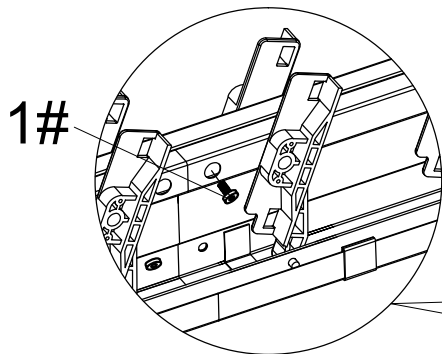
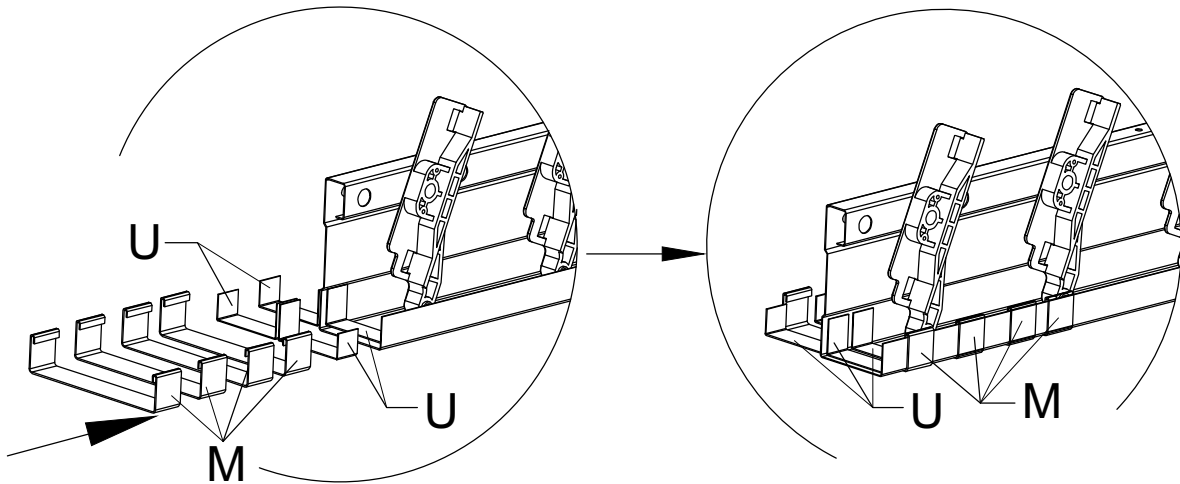

Secure M1/M2 ends with 2 bolts #1, and secure each middle connection with 1 bolt #1.
 Repeat above procedures to assemble the other set of beams.

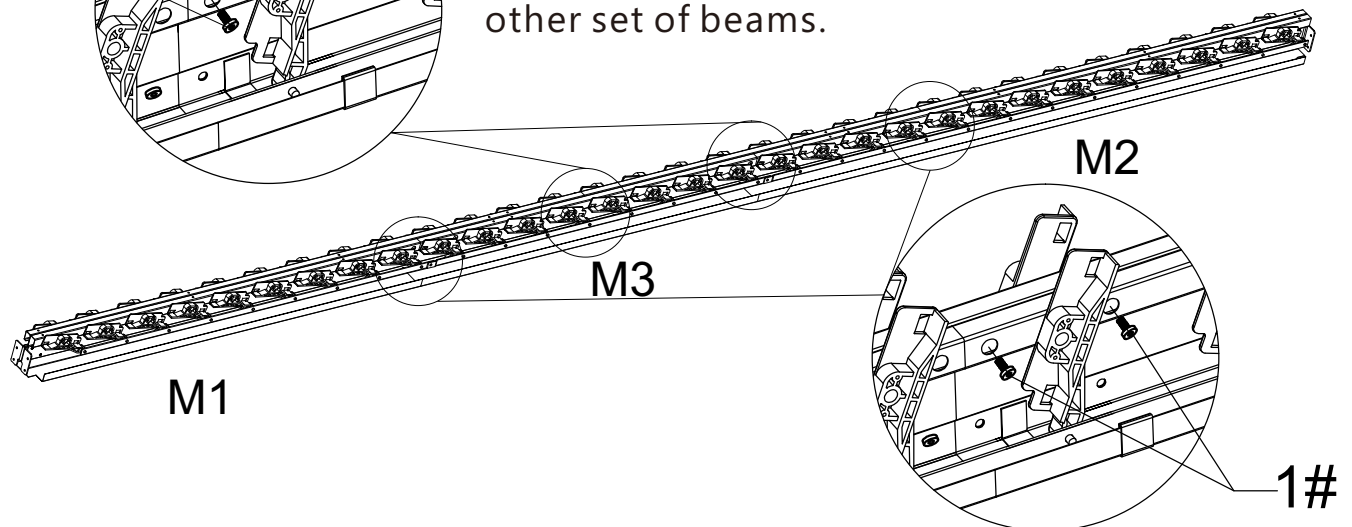

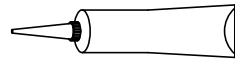
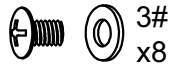

11#

Apply waterproof sealant to fill the inner side of the gap, then push part #U onto the joint to seal it.

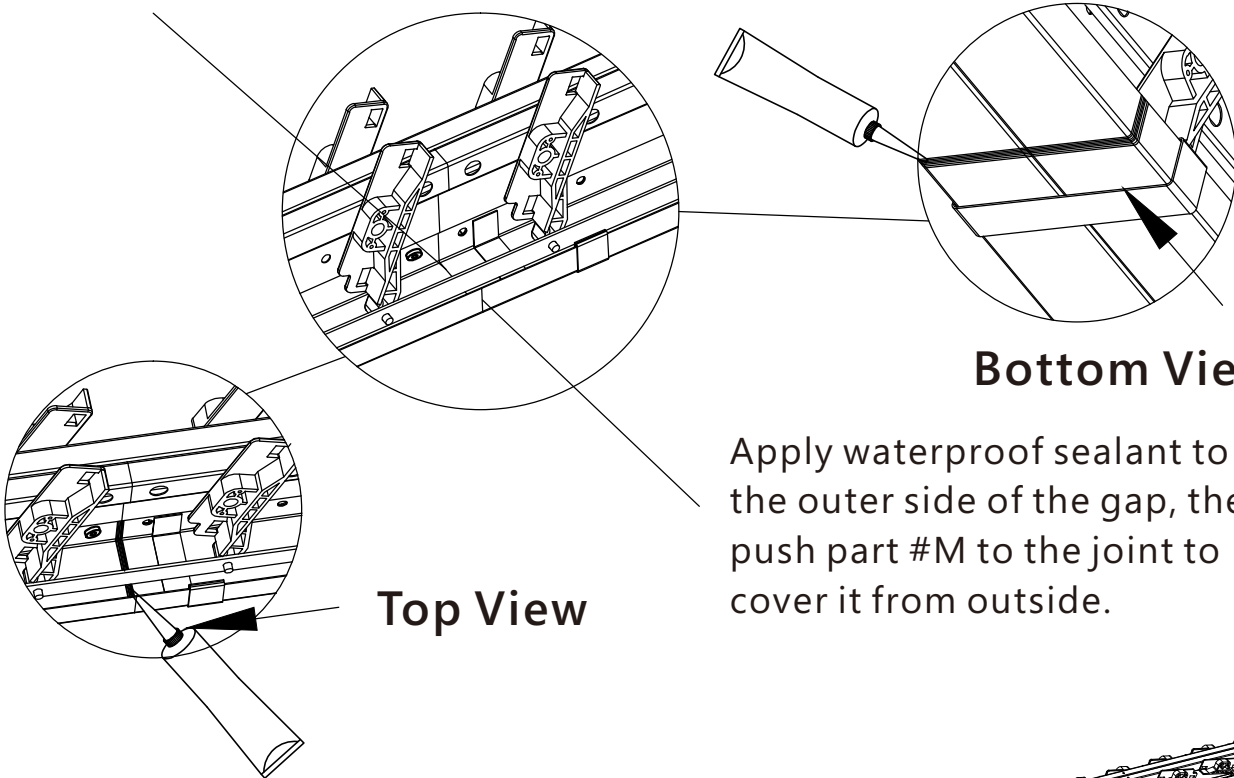

Top View

Bottom View

Apply waterproof sealant to fill the outer side of the gap, then push part #M to the joint to cover it from outside.

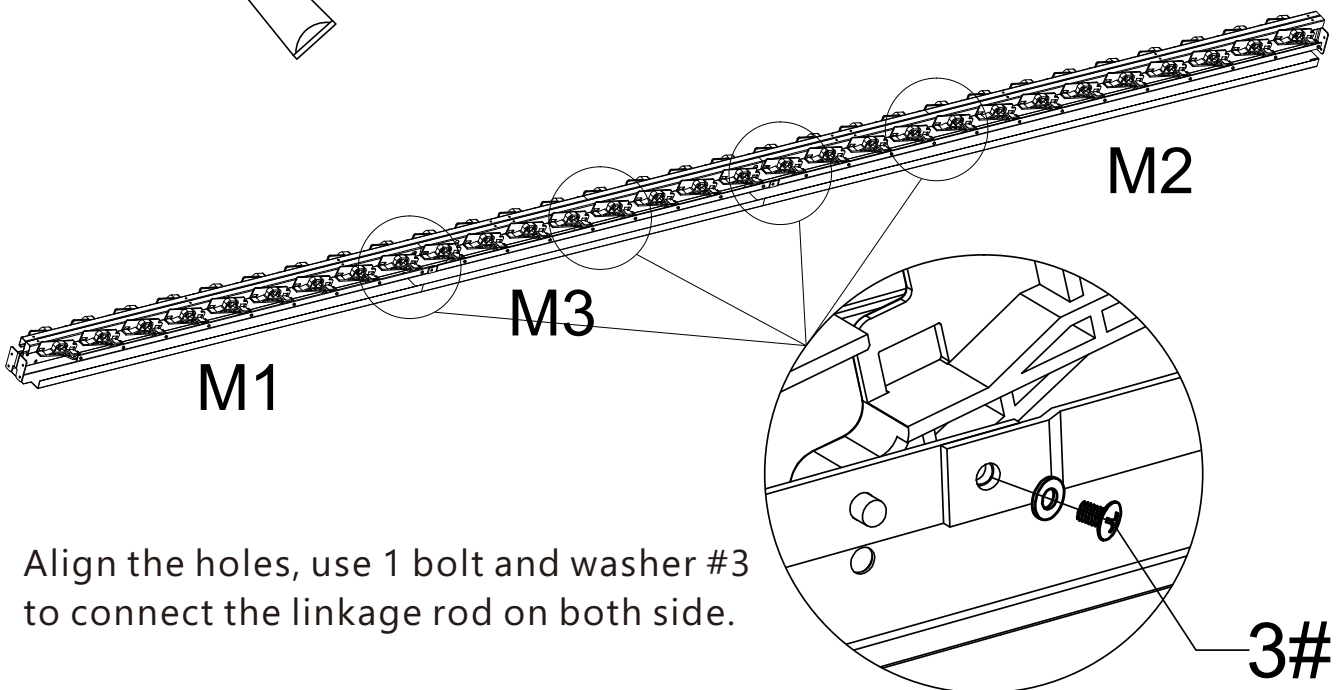

Align the holes, use 1 bolt and washer #3 to connect the linkage rod on both side.

3#

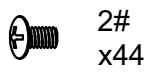
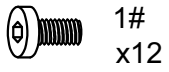
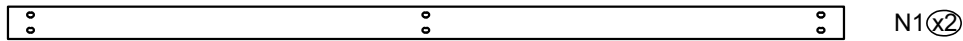
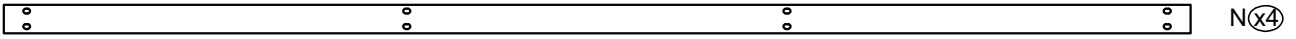

Secure M1/M2 ends with 2 bolts #1, and secure each middle connection with 1 bolt #1.

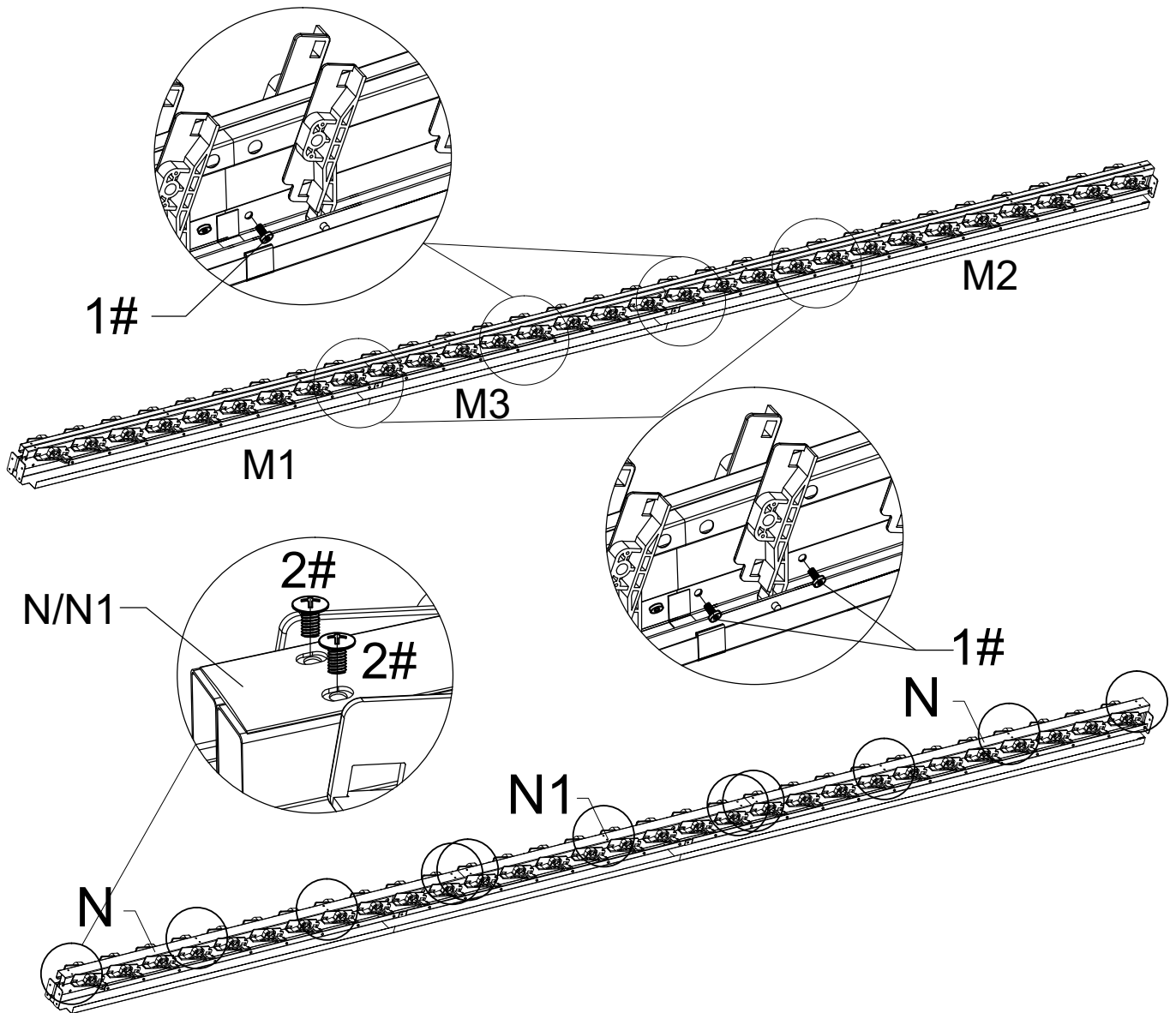

Place Gap Cover #N/#N1 on the beam, align the holes and fix with 22 bolts #2. Repeat above steps to assemble the other set of beams.

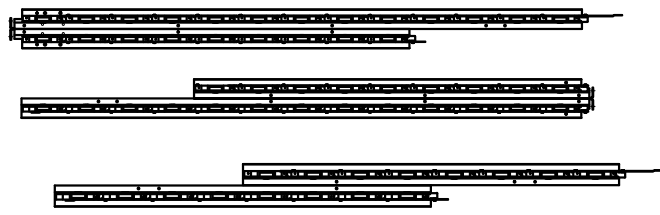

M4(x1)

M5(x1)

M3(x1)

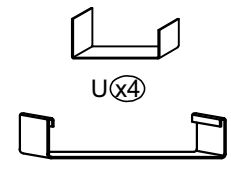

U(x4)

M(x4)



1#
x6

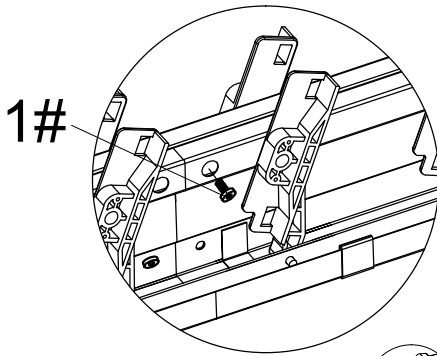
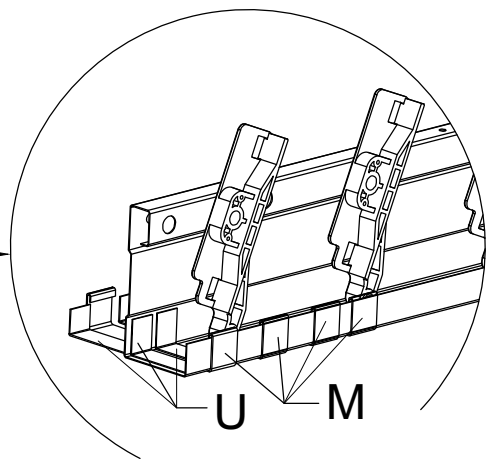
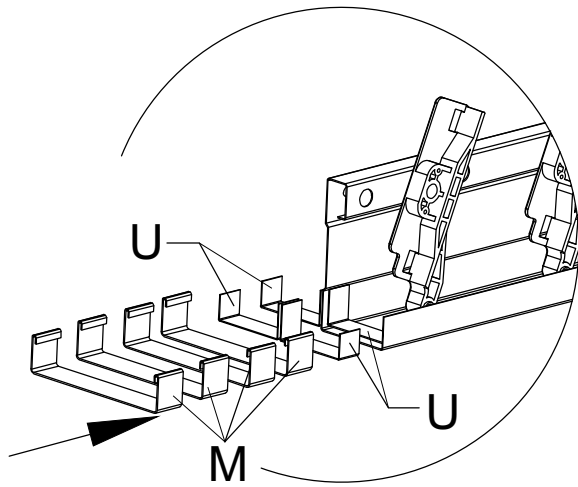

1#

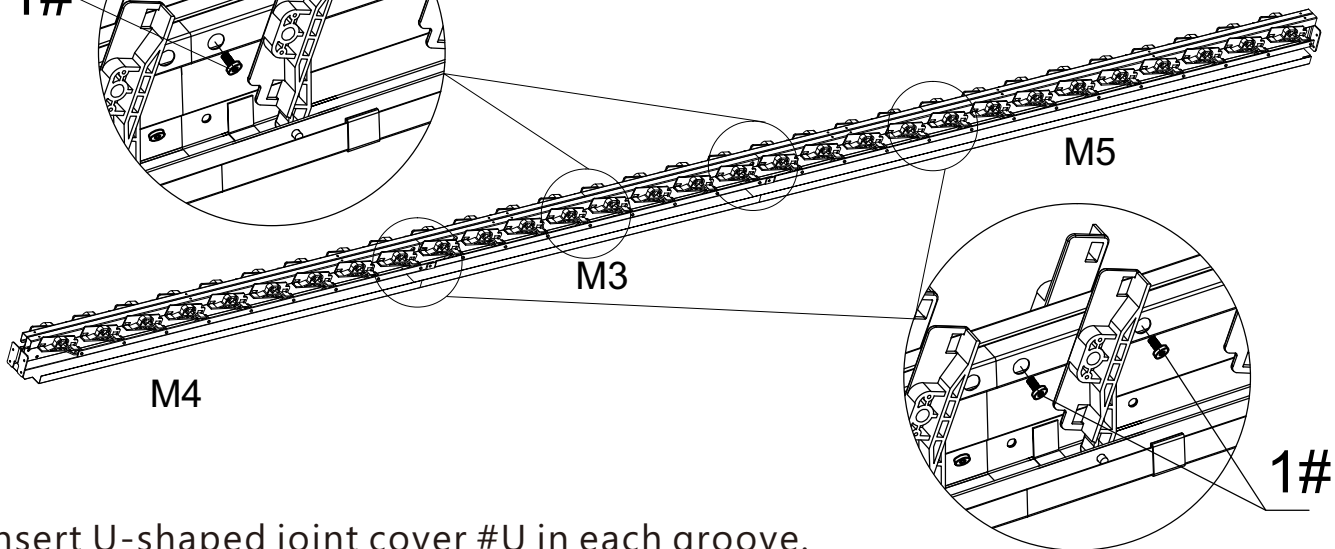

M5

M3

M4

1#

Insert U-shaped joint cover #U in each groove.

Snap U-shaped joint cover #M from the bottom, then connect the two beams (M4 & M3, M3 & M5).

Secure M4/M5 ends with 2 bolts #1, and secure each middle connection with 1 bolt #1.

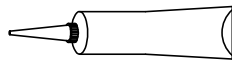

11#

Apply waterproof sealant to fill the inner side of the gap, then push part #U onto the joint to seal it.

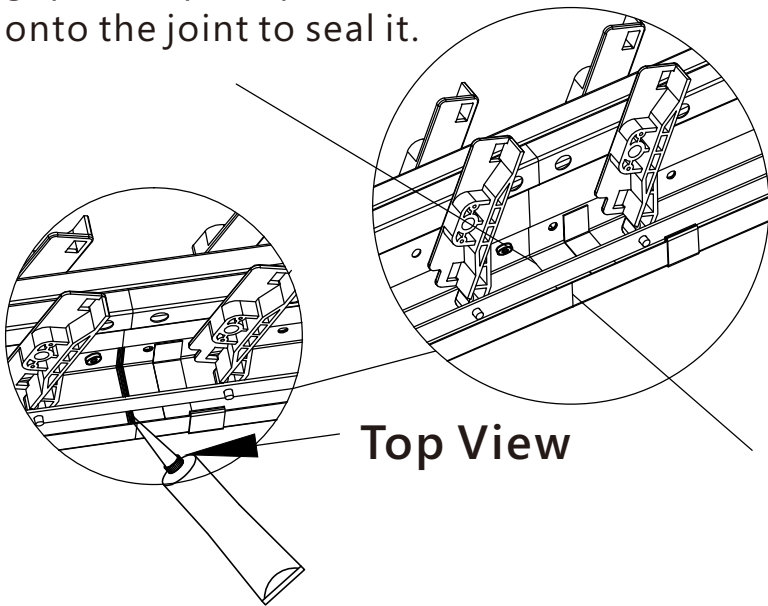

Top View

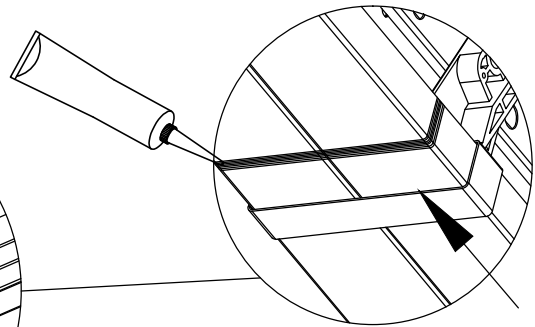

Bottom View

Apply waterproof sealant to fill the outer side of the gap, then push part #M to the joint to cover it from outside.

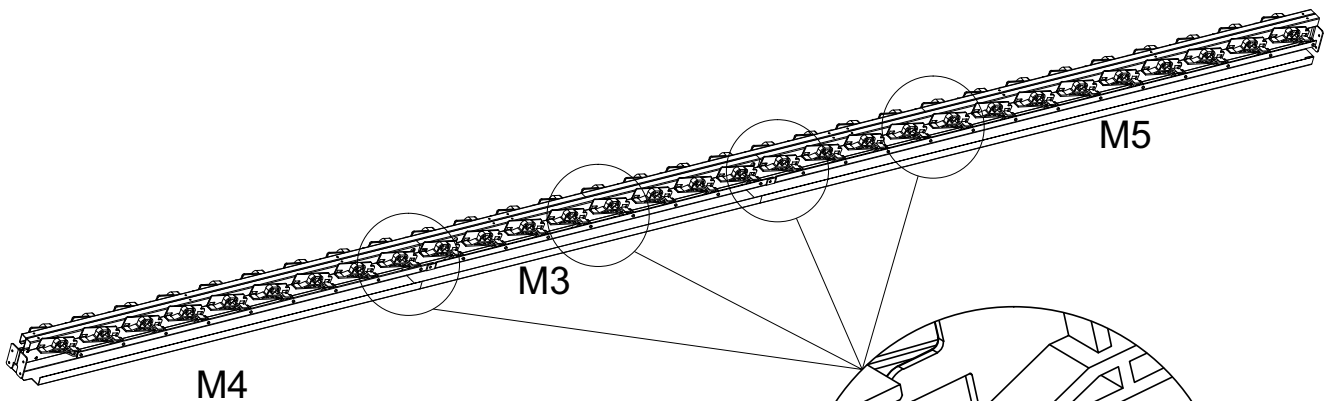

Align the holes, use 1 bolt and washer #3 to connect the linkage rod on both side.

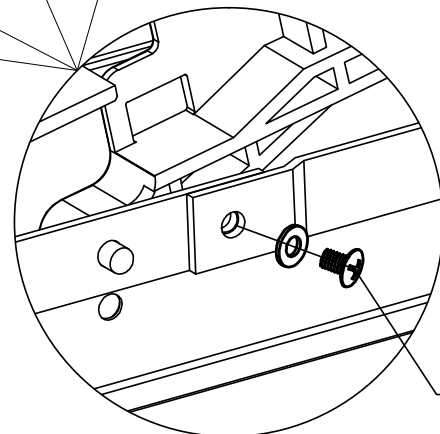

3#

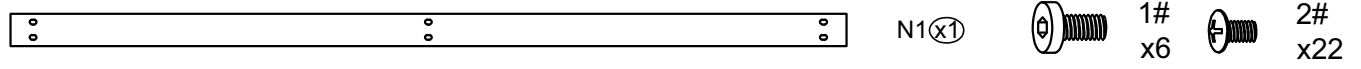
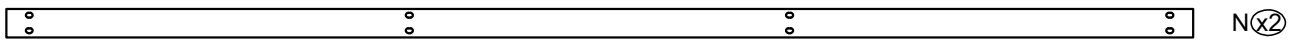

Secure M4/M5 ends with 2 bolts #1, and secure each middle connection with 1 bolt #1.

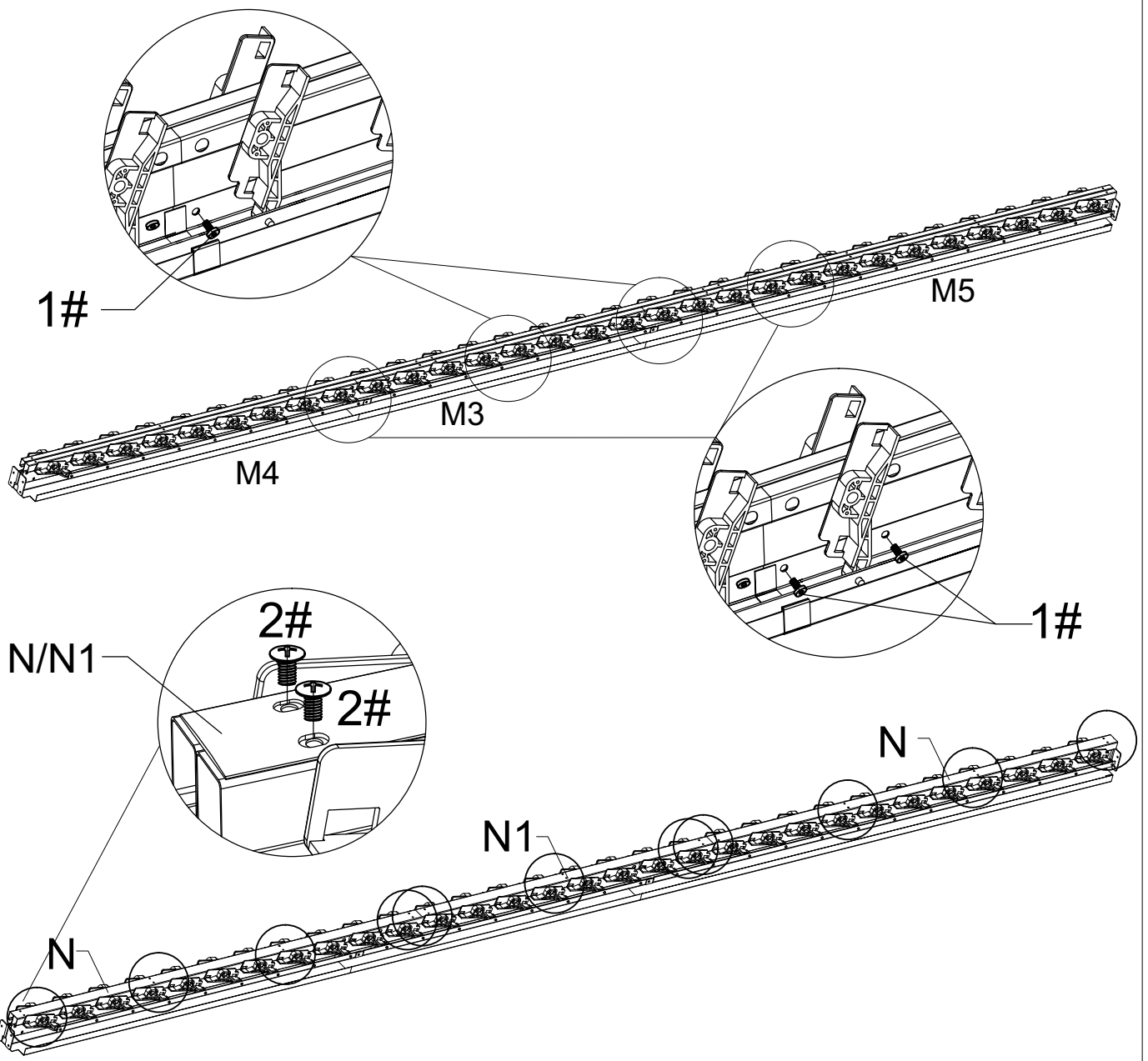

Place Gap Cover #N/#N1 on the beam, align the holes and fix with 22 bolts #2.



1#
x8

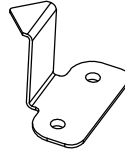

L1(x4)

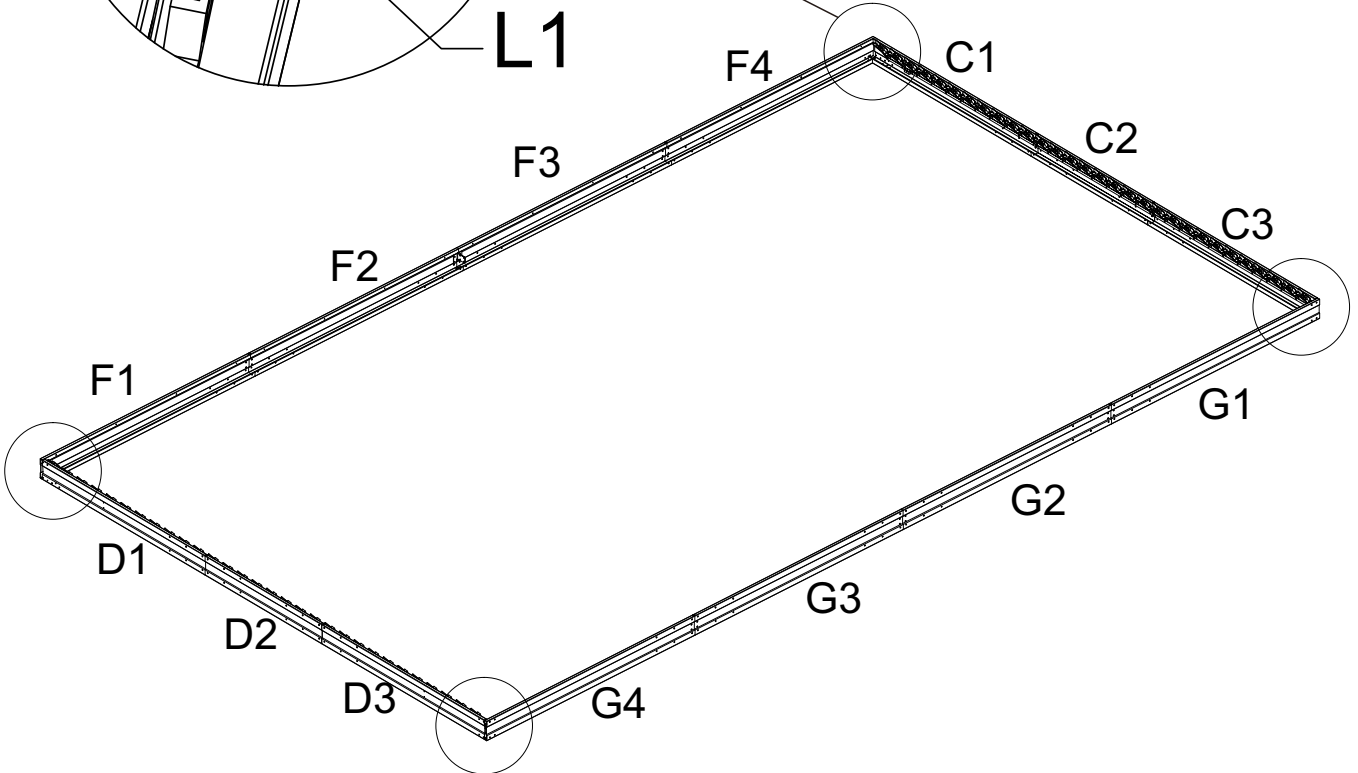
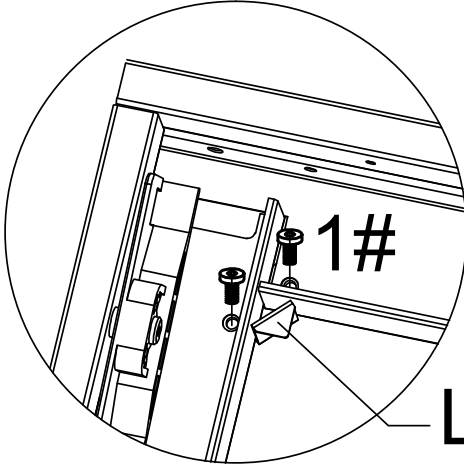

Attention: Before assembling the beams, ensure that all the Linkage Rods are facing down and the plastic pieces are facing up.

Connect the beams as shown, align the holes and use bolts #8 and brackets #L1 to secure each corner.



A2(x4)

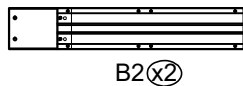

B2(x2)



1#
x40

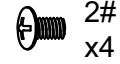

2#
x4

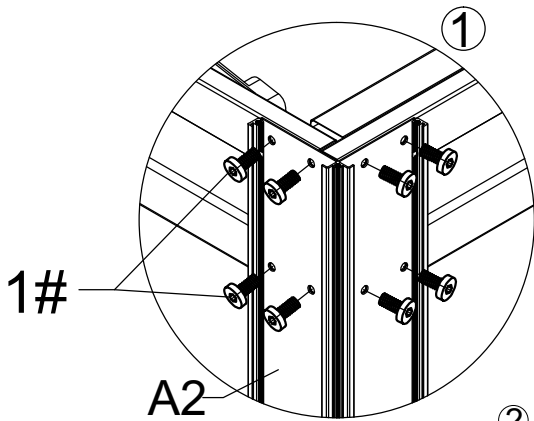

①: Use 8 bolts #1 to secure the connector #A2 to each corner of the beam. Repeat above procedures to assemble the other 3 sides.

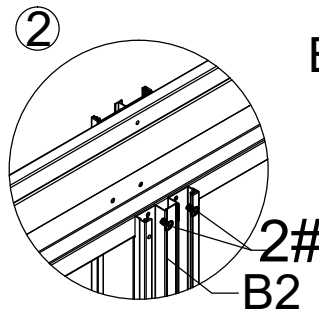
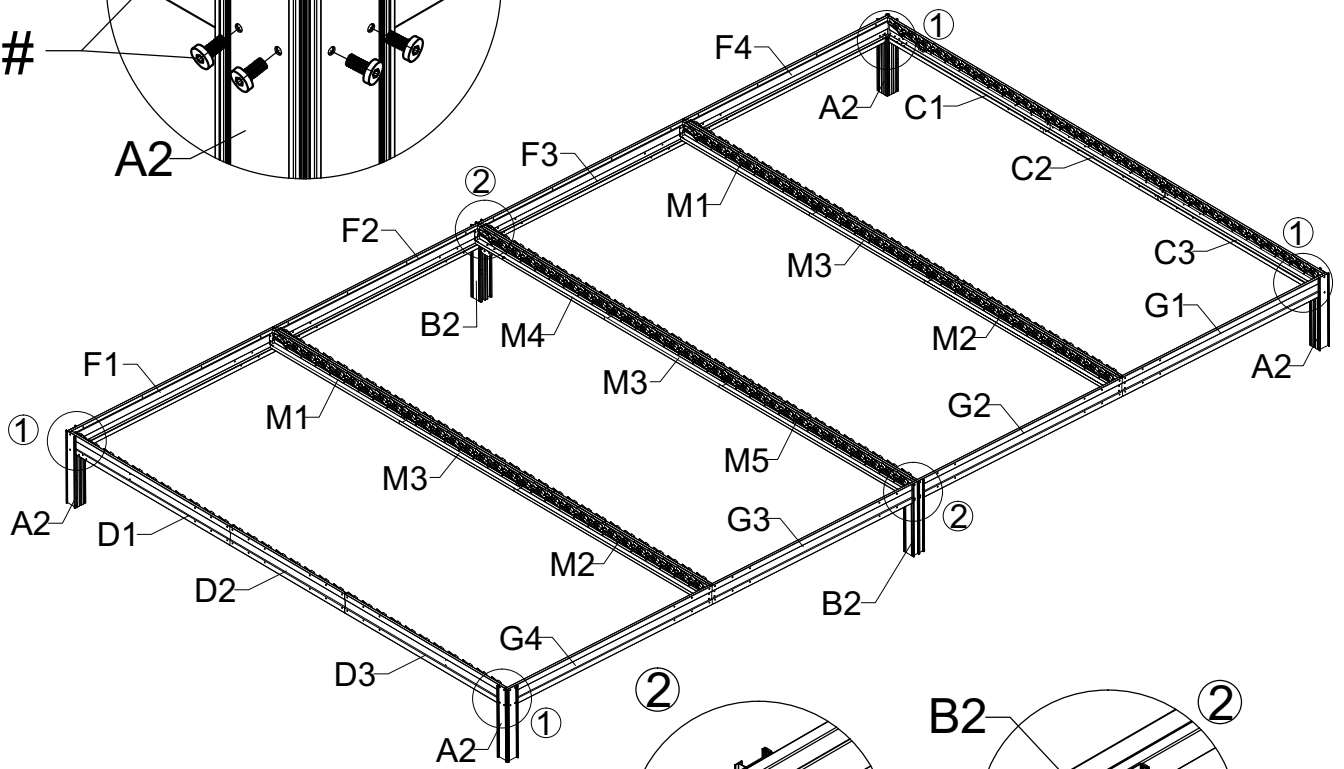

Inside view

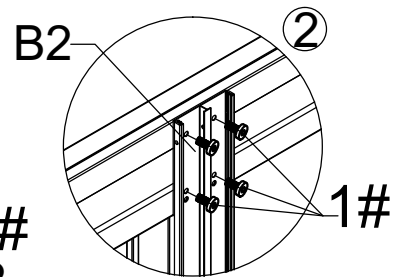

Outside view

②: Use 4 bolts #1 to secure the connector #B2 to the centre of the beam as shown(from outside). Use 2 bolts #2 to secure the connector #B2 to the centre of the beam as shown(from inside). Repeat above procedures to assemble the opposite side.



1#
x16

③: Use 4 bolts #1 to fix the beam #M1/M2 to the side beam as shown. Repeat above procedures to assemble the other 3 sides.

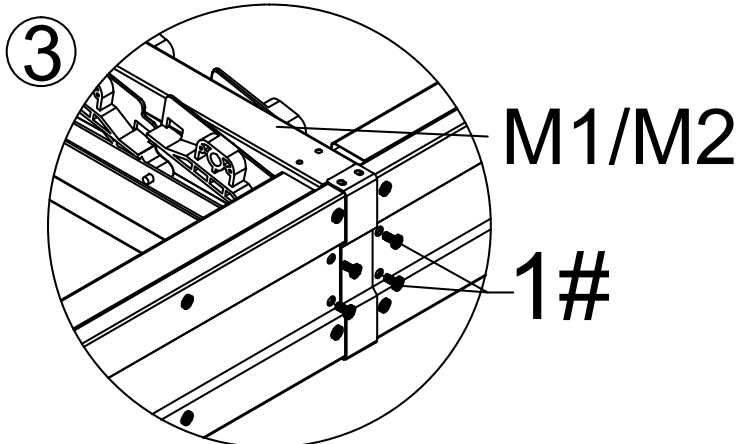
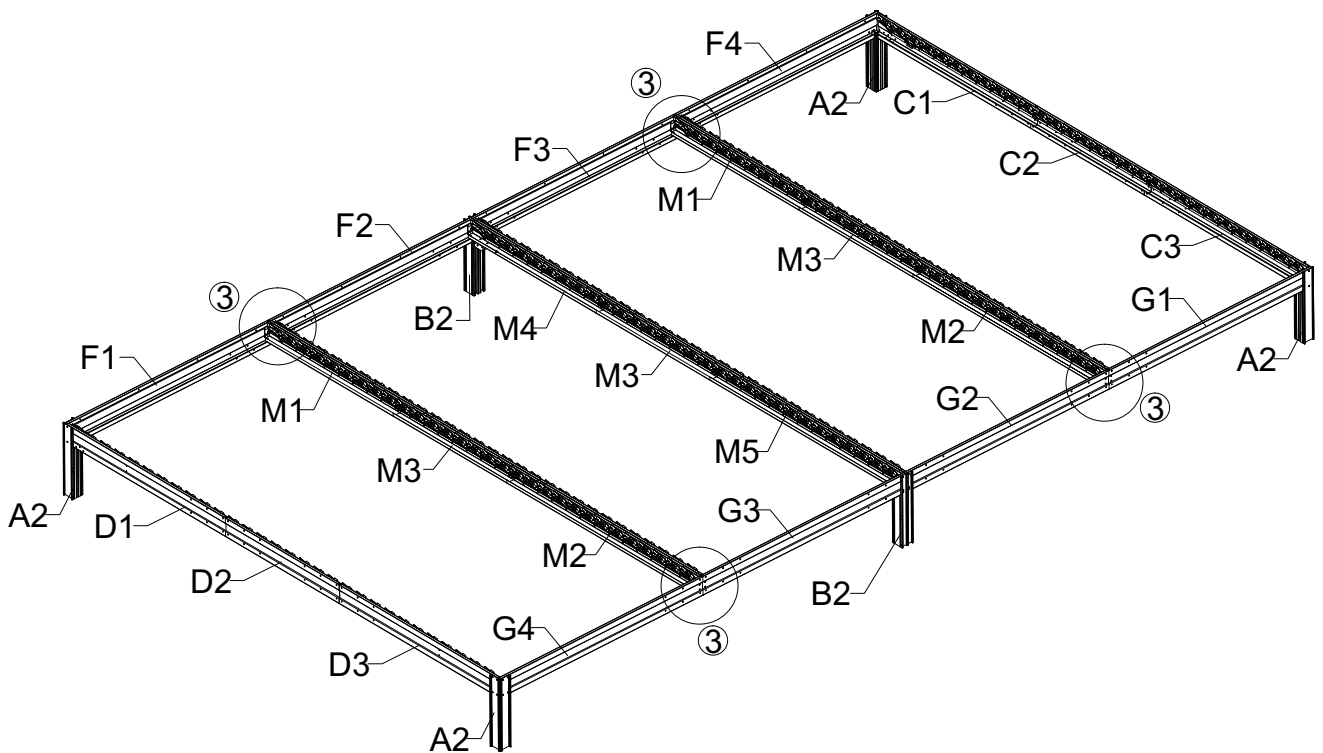

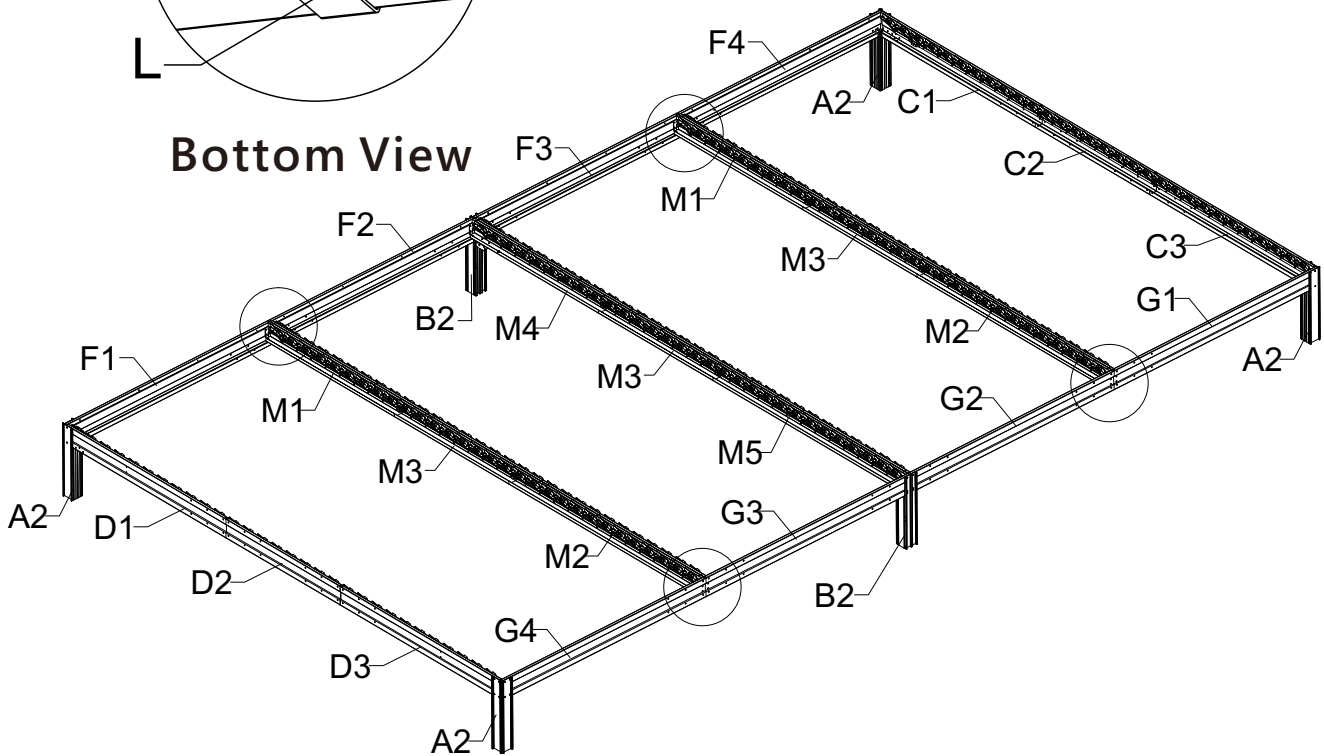
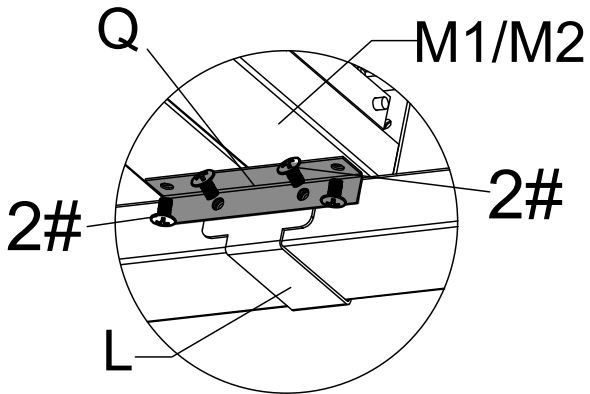
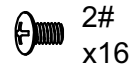
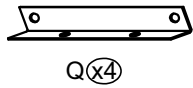

③: Use 2 bolts #2 to secure the connector #Q to the beam as shown. Place the beam #M1&M2 onto the connector #Q, align the holes and secure with 2 bolts #2. Repeat above procedures to assemble the other 3 sides.

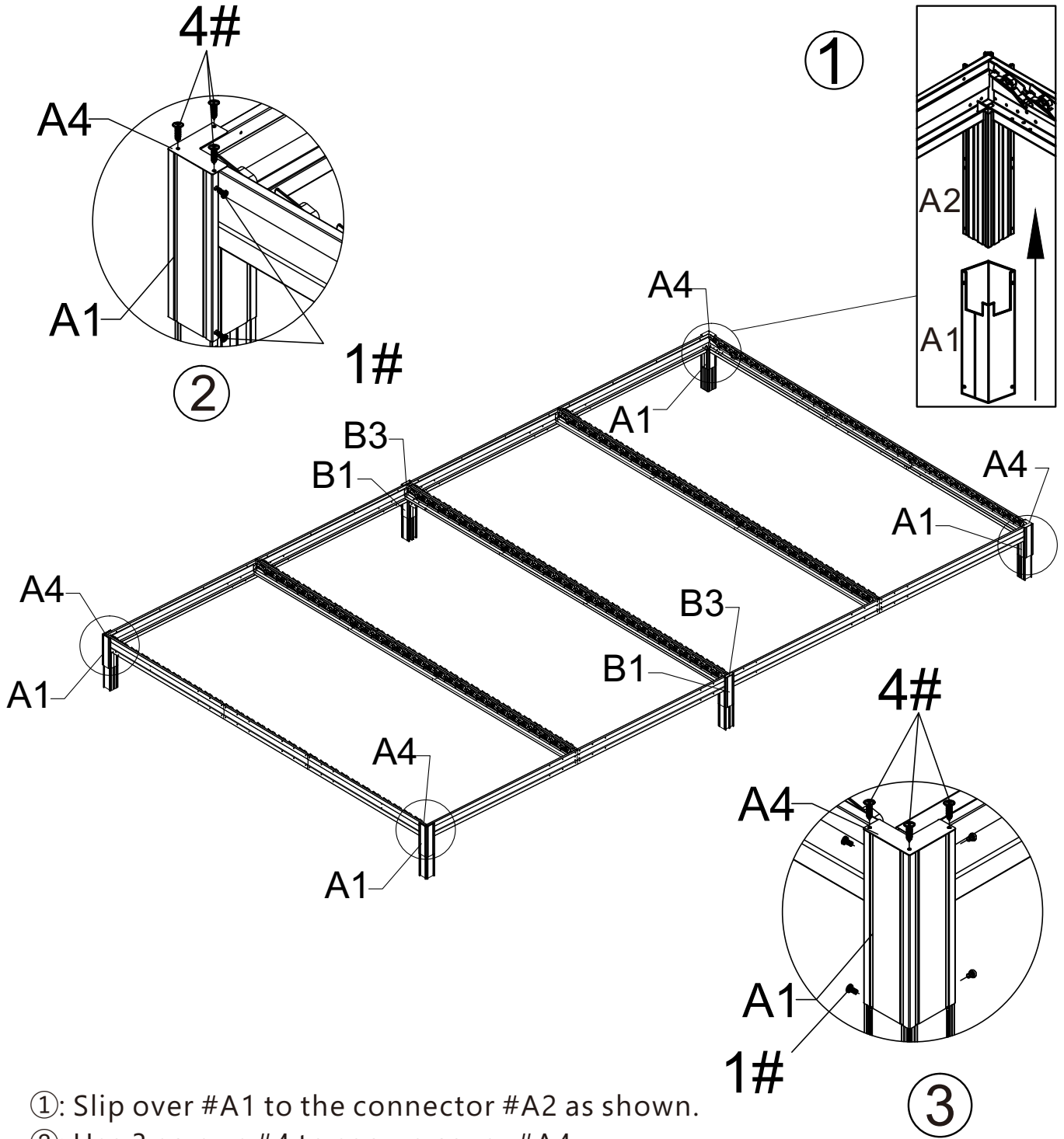
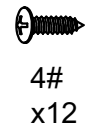
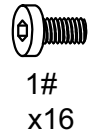
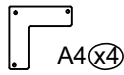
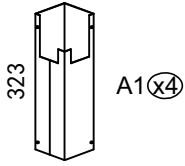

- ①: Slip over #A1 to the connector #A2 as shown.
 - ②: Use 3 screws #4 to secure cover #A4.
 - ③: Use 4 bolts #1 to secure #A1 to the connector #A2.
- Repeat above procedures to assemble the other 3 sides.

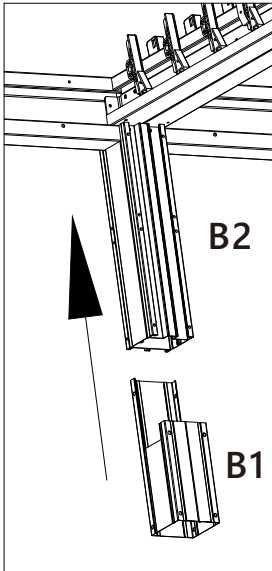
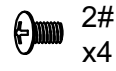
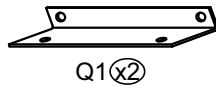
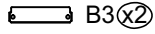
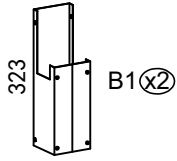

1

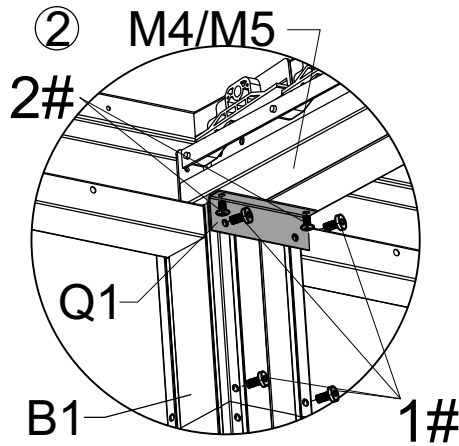

Inside View

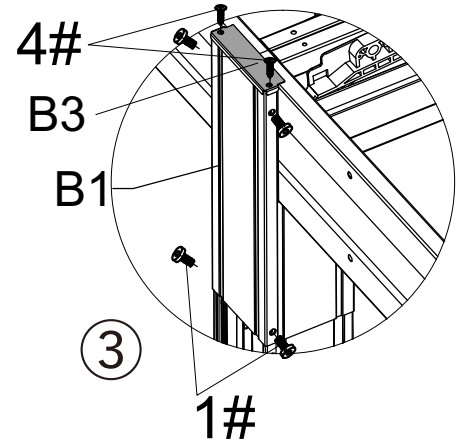

Outside View

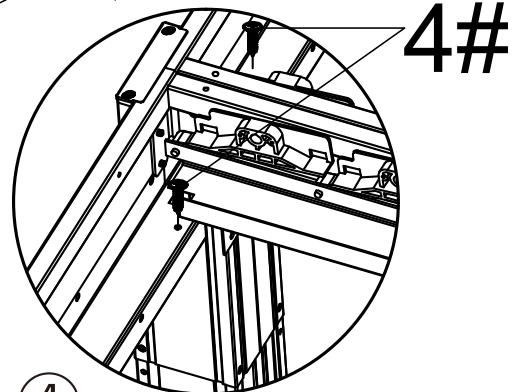
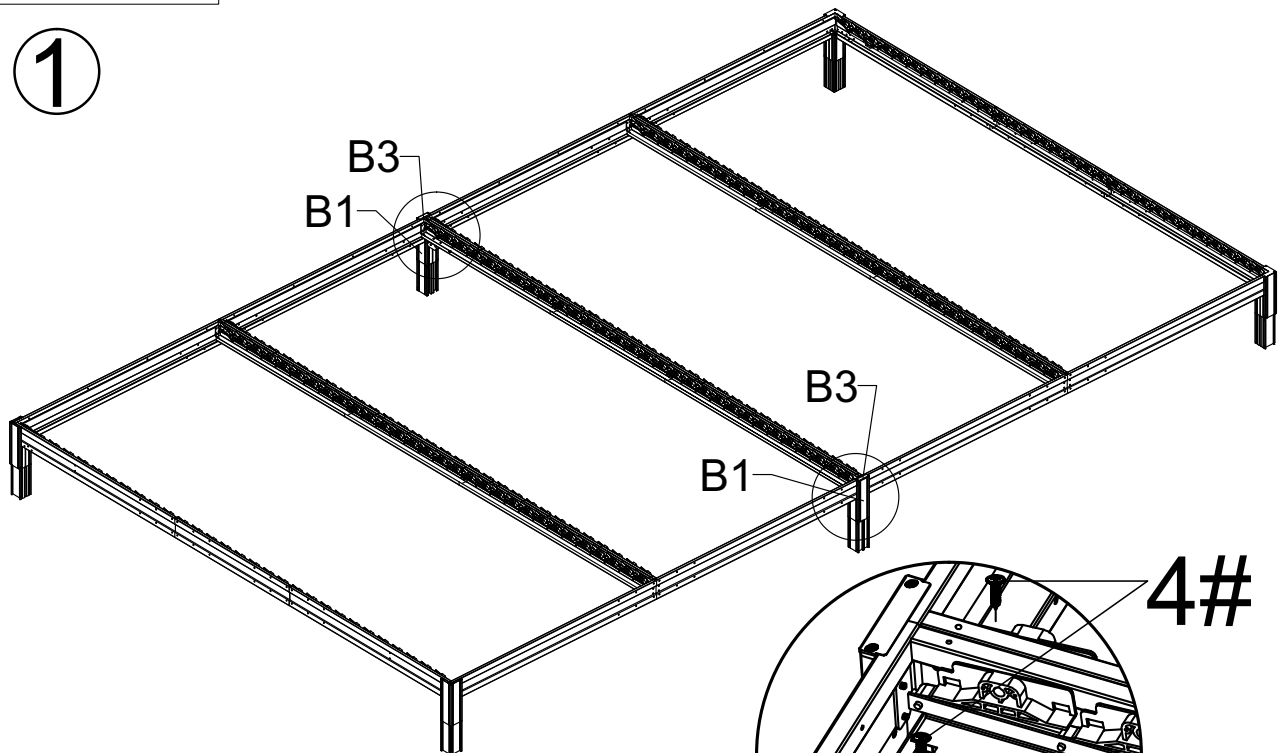

Top View

①: Slip over #B1 to the connector #B2 as shown.

②: Use 2 bolts #2 to secure connector Q1 to beam #M4/M5.

Use 2 bolts #1 to secure #Q1 to the #B2.

Use 2 bolts #1 to secure #B1 to connector #B2.

③: Use 2 screws #4 to secure cover #B3.

Use 4 bolts #1 to secure #B1 to the connector #B2.

④ Use 2 screws #4 to secure the beam.

Repeat above procedures to assemble the opposite side.

Installation Tip:



1#
x32

To install parts #A and #B, first lay the crossbeam frame on its side (rotate 90° toward #G1-G4). Attach poles to one side (#F1-F4), then flip the frame over to attach poles to the opposite side. Finally, rotate the frame upright.

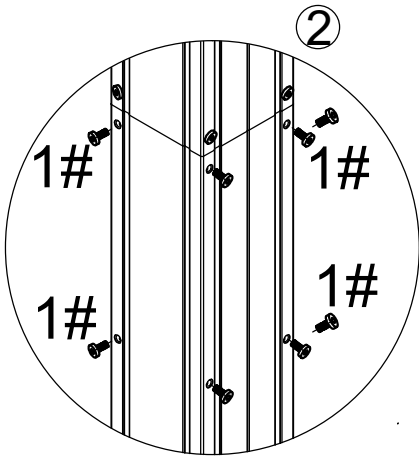

①: Use 4 bolts #1 to assemble pole A. Repeat above procedures to assemble the other 3 sides.

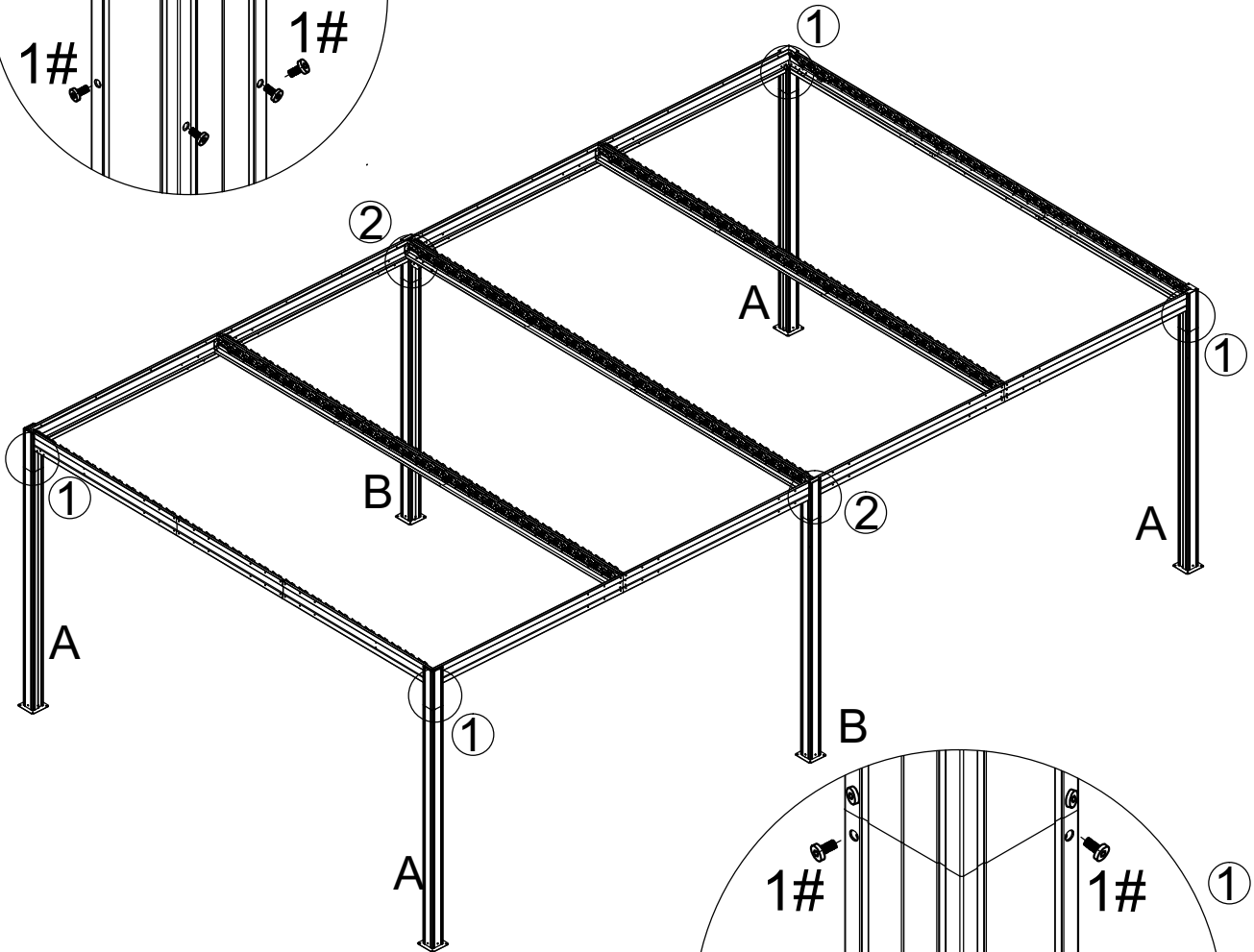

②: Use 8 bolts #1 to assemble pole B. Repeat above procedures to assemble the opposite side.

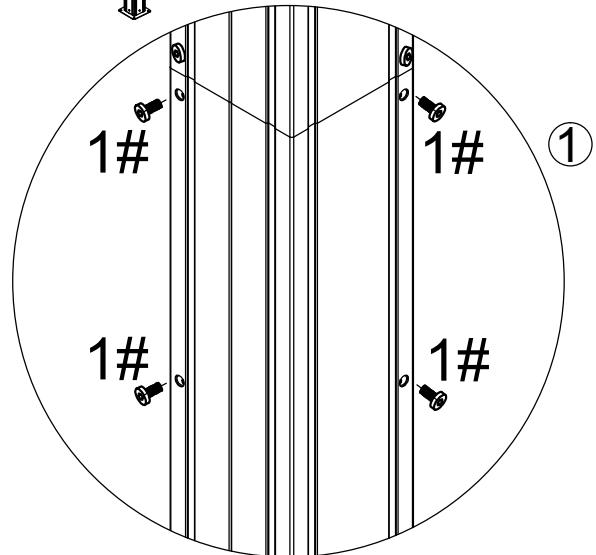



1#
x8

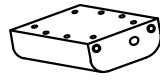

E(x1)

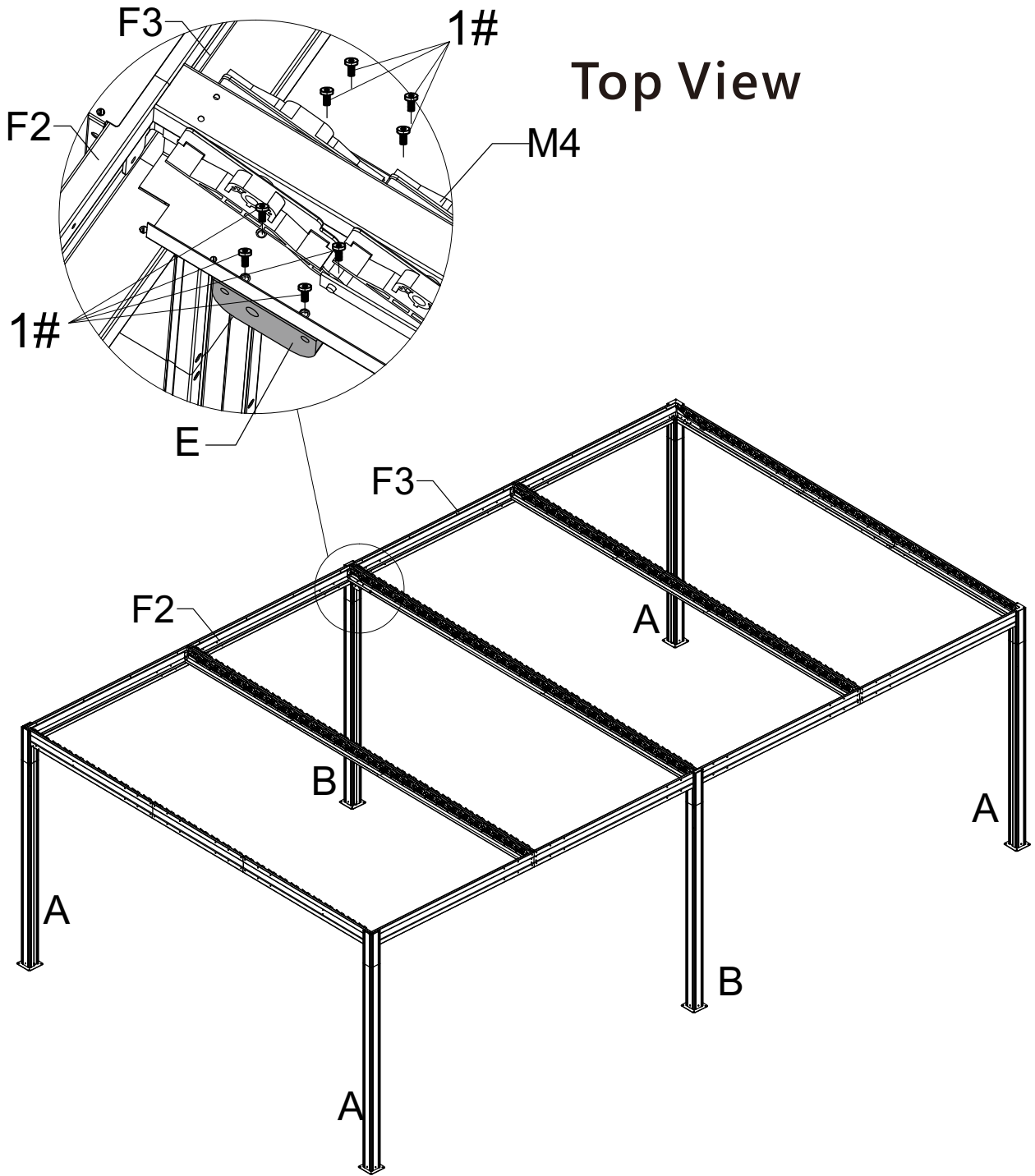

Use 8 bolts #1 to secure part #E under the centre beam.

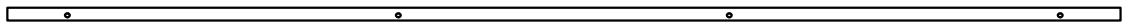

H(x4)

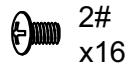

Use 16 bolts #2 to assemble Rain Guard #H to the beam #G1/G2/G3/G4.

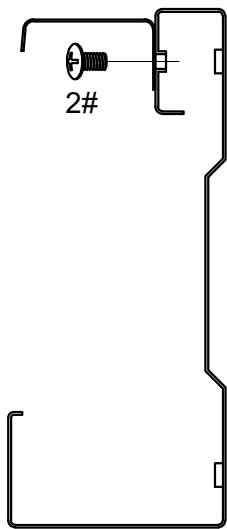
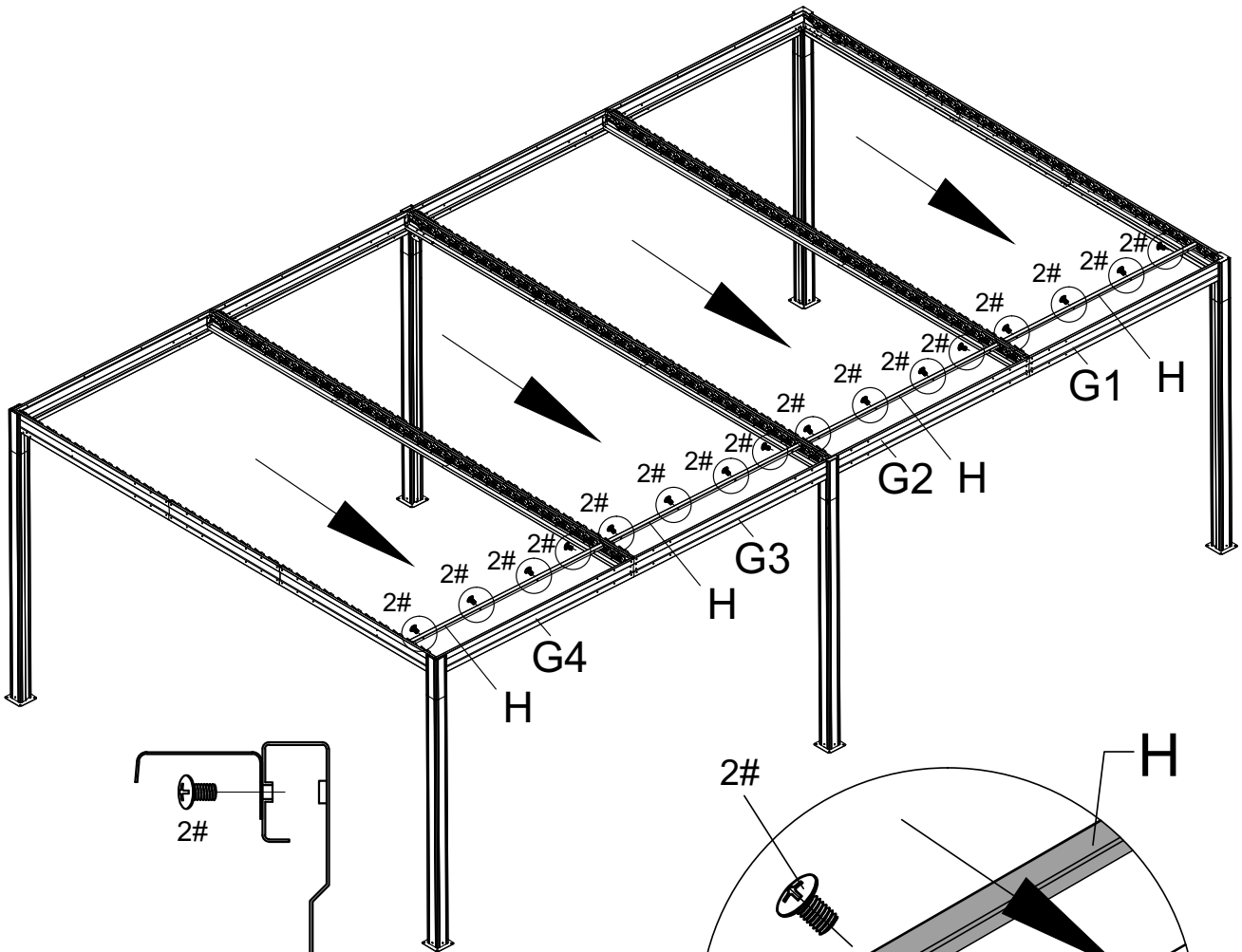

Section View

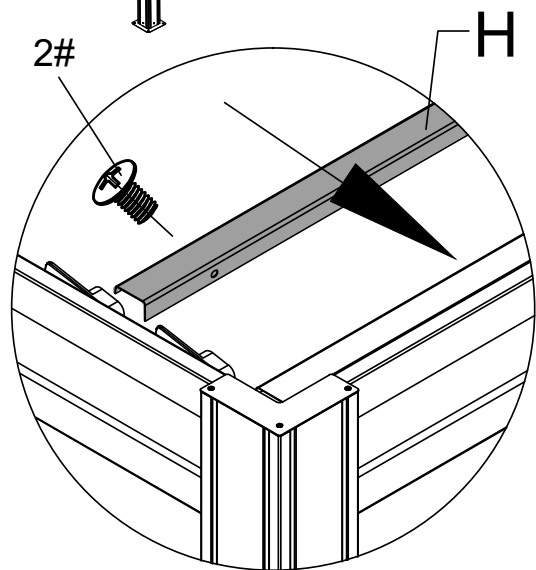

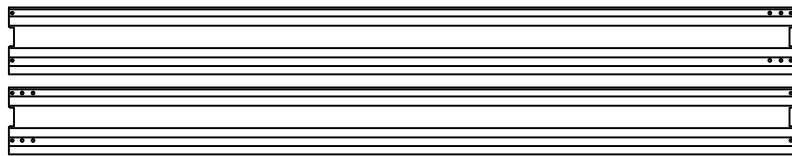

P1(x1)

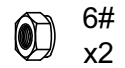
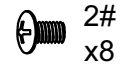

P2(x1)

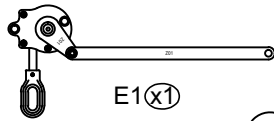
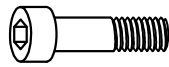
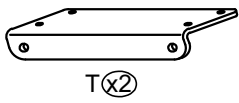
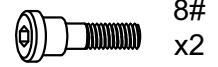
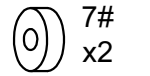

E1(x1)

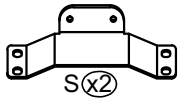

T(x2)



5# x4

R(x2)

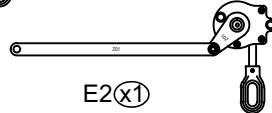

E2(x1)

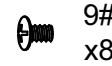

9# x8

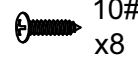

10# x8

Bottom View

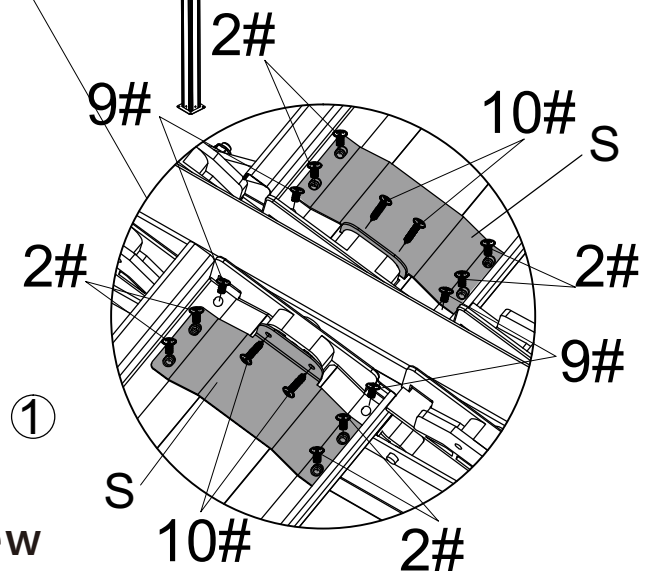
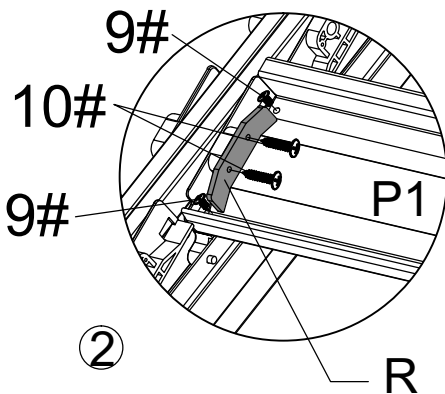
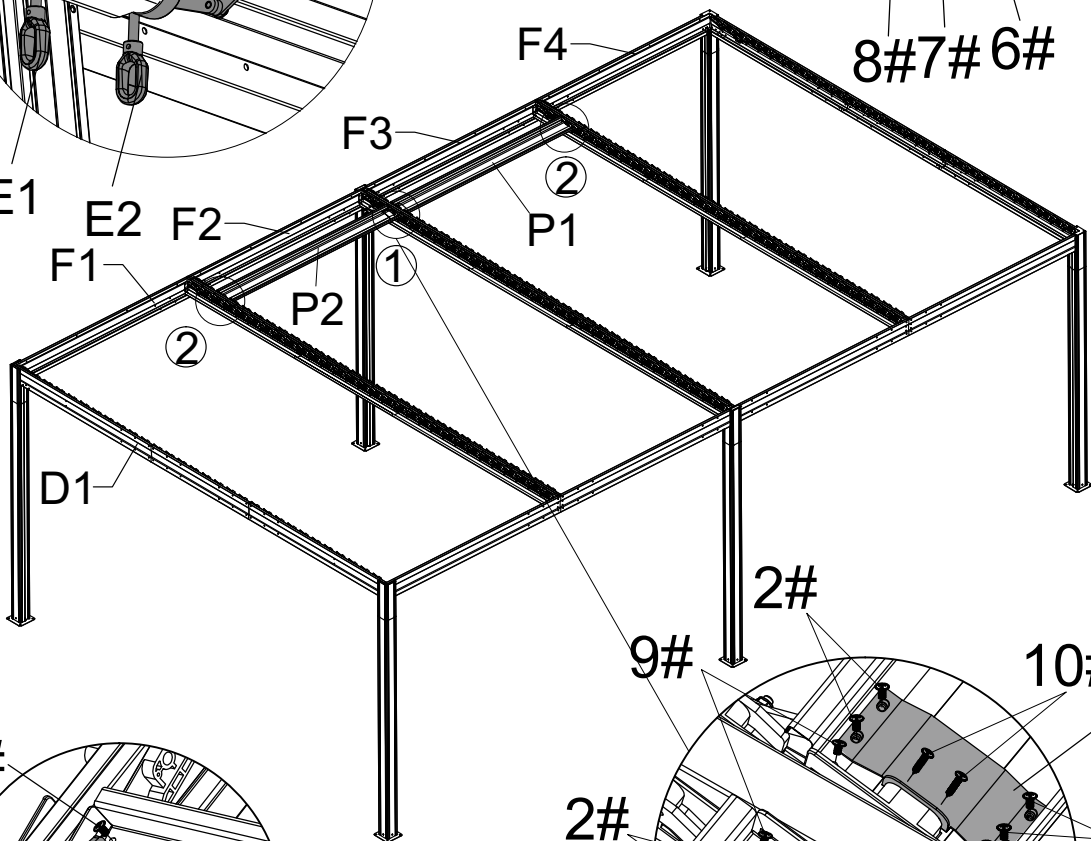
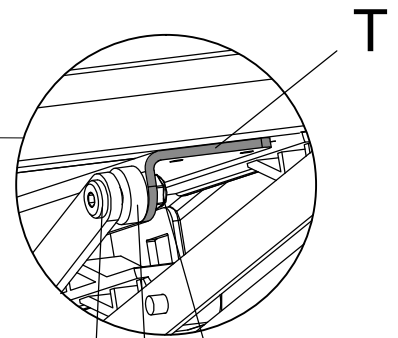
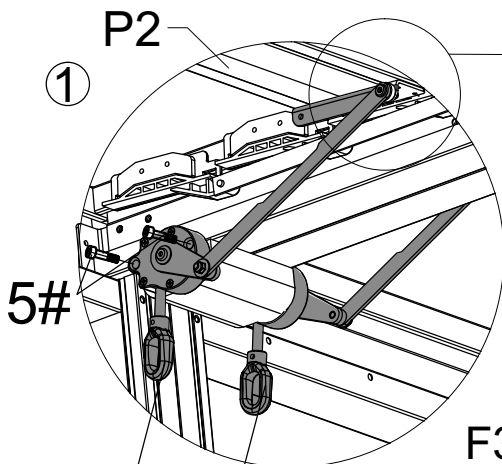

Top View

①: Use 4 bolts #5 to secure part #E1 and #E2 to part #E respectively.

Use 1 bolt #8, plastic gasket #7 and nut #6 to secure the rod (on #E1) with part #T.

Repeat the above procedures to secure the rod (on #E2) with part #T.

Place the louver panel #P1/#P2 on the third plastic bracket on the installed linkage rod as shown, and secure it with 2 screws #9 on each side.

Place part #S on the panel #P1/#P2, align the holes, use 8 bolts #2 to secure part #S, panel #P1/#P2 with part #T. (Clip the panel between part #S and #T).

Use 4 screws #10 to secure part #S to the plastic bracket (already assembled on the linkage rod).

②: Use 2 screws #9 to secure the panel to the plastic bracket (already assembled in the linkage rod).

Use 2 screws #10 to secure plastic clips #R to the plastic bracket (already assembled in the linkage rod).

Repeat to assemble all remaining louver panels.

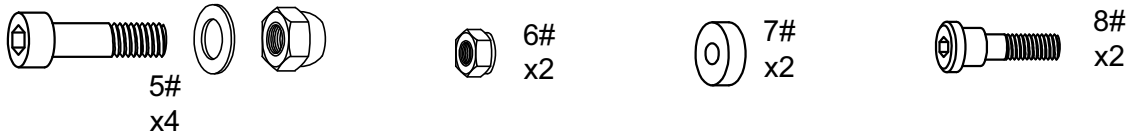
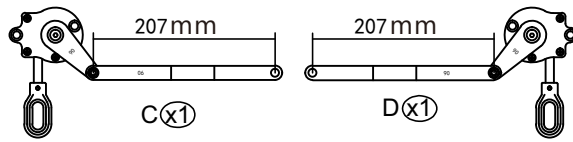

Use 2 bolts, washers and nuts #5 to secure part #C to #K1 (already assembled on beam #C1). Use 1 Bolt #8, plastic gasket #7 and nuts #6 to secure the rod (on #C) with linkage rod. Repeat above procedures to assemble part #D to #K2 (already assembled on beam #D1).

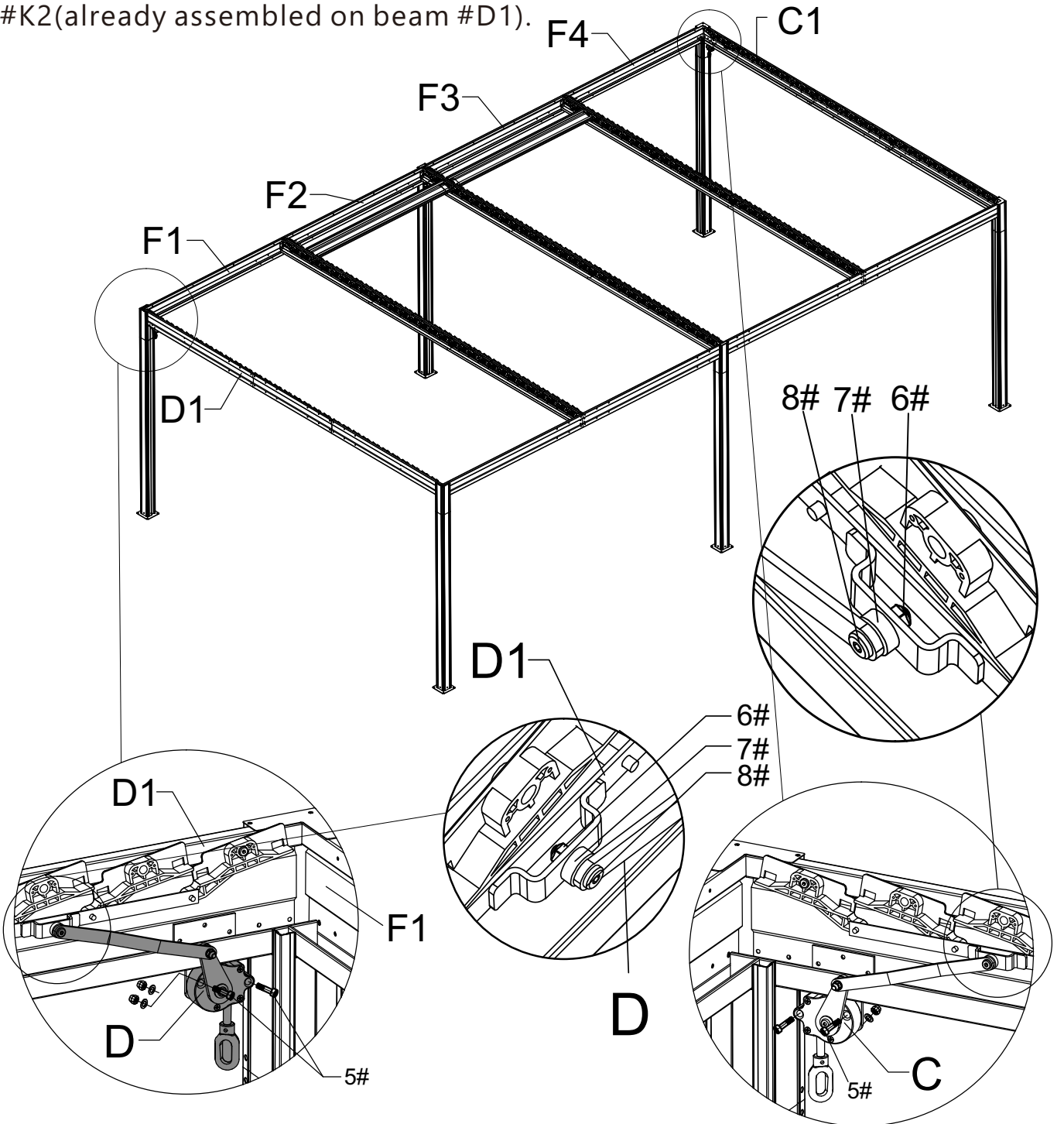

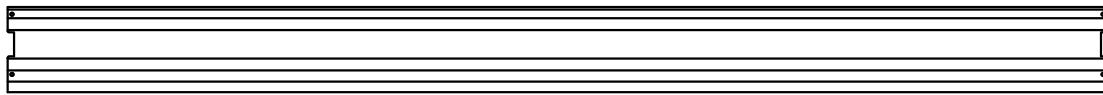

P(x118)

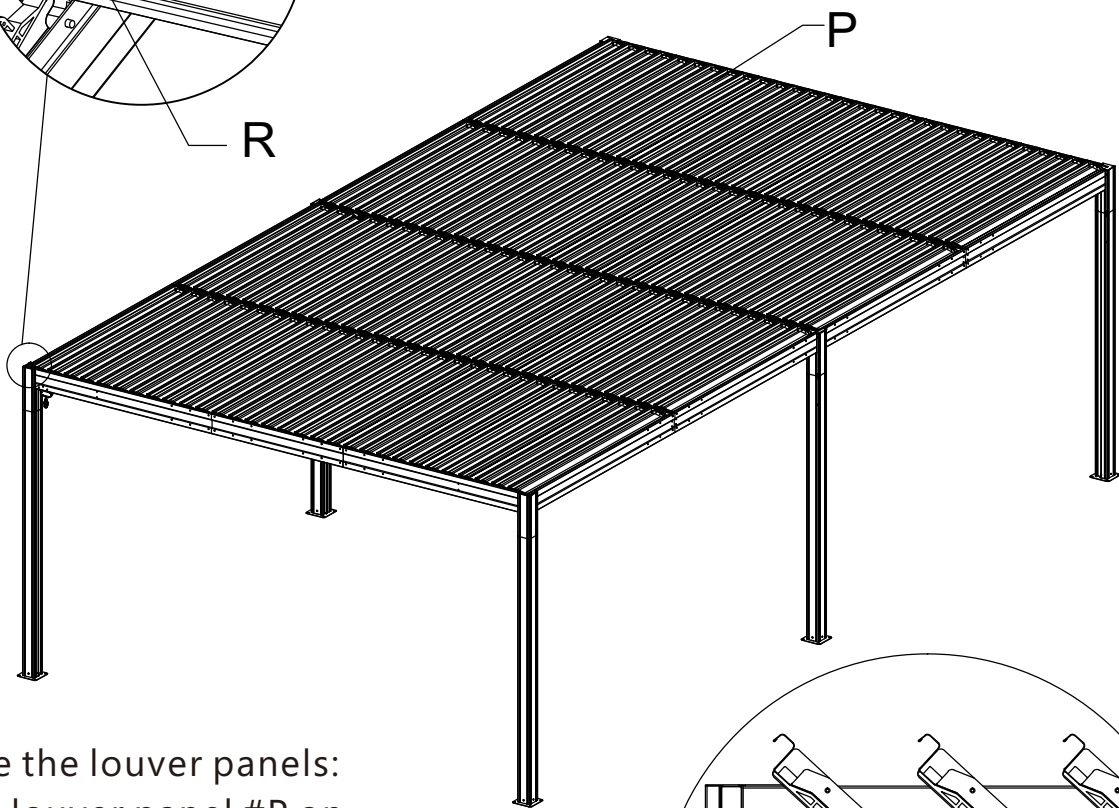
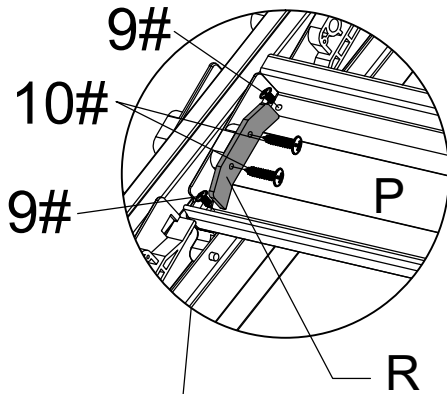
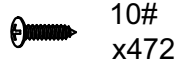
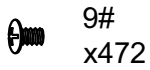

Assemble the louver panels:
Place the louver panel #P on the plastic bracket(already assembled in the linkage rod), and secure with 2 screws #9 on each side.
Use 2 screws #10 to secure plastic clips #R to the plastic bracket(already assembled in the linkage rod) on each side.
Repeat above procedures to assemble the remained louver panels.

Notice: Open the louvers to prevent snow accumulation when moderate to heavy snow is forecast.

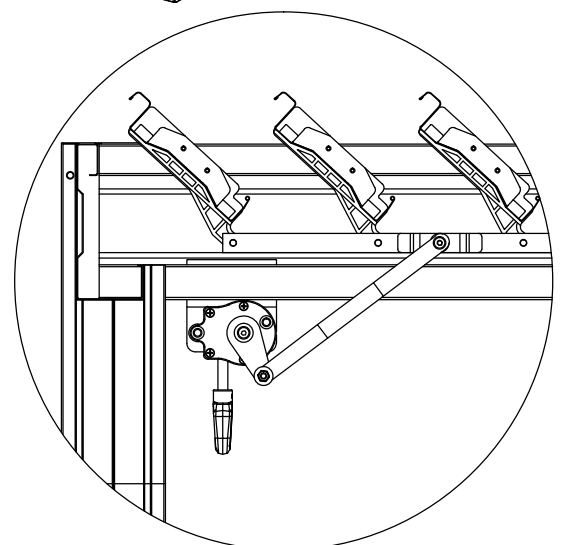

Installation Diagram of louver panels.

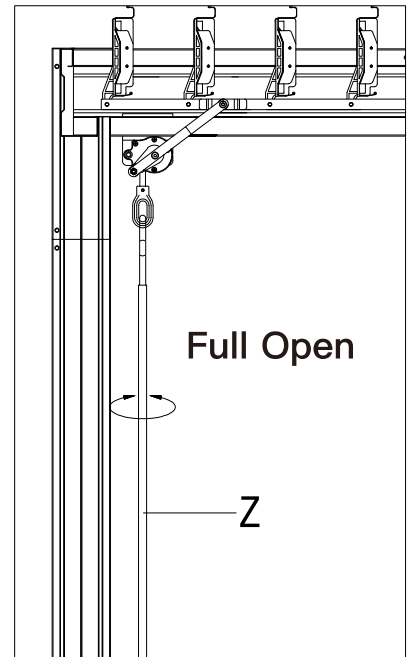
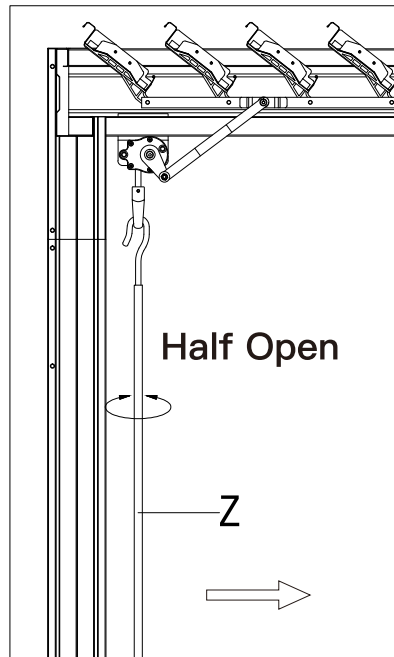
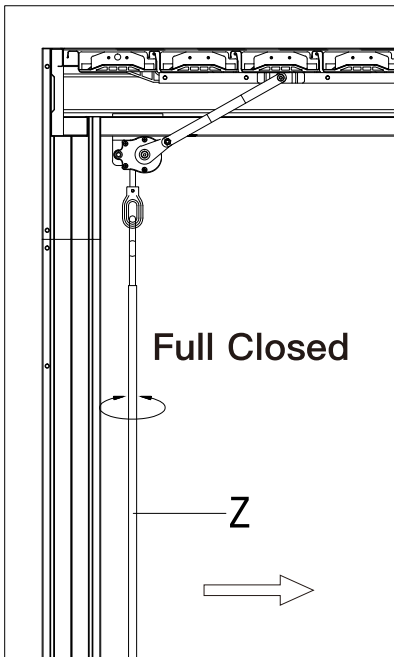

Just shake the roller rod anytime you want let the sun in or block the sunray. If moderate to heavy snow is forecast, pls open the louvers to avoid snow accumulating.



(ATTENTION: Louvers can be opened and closed in cycles.)

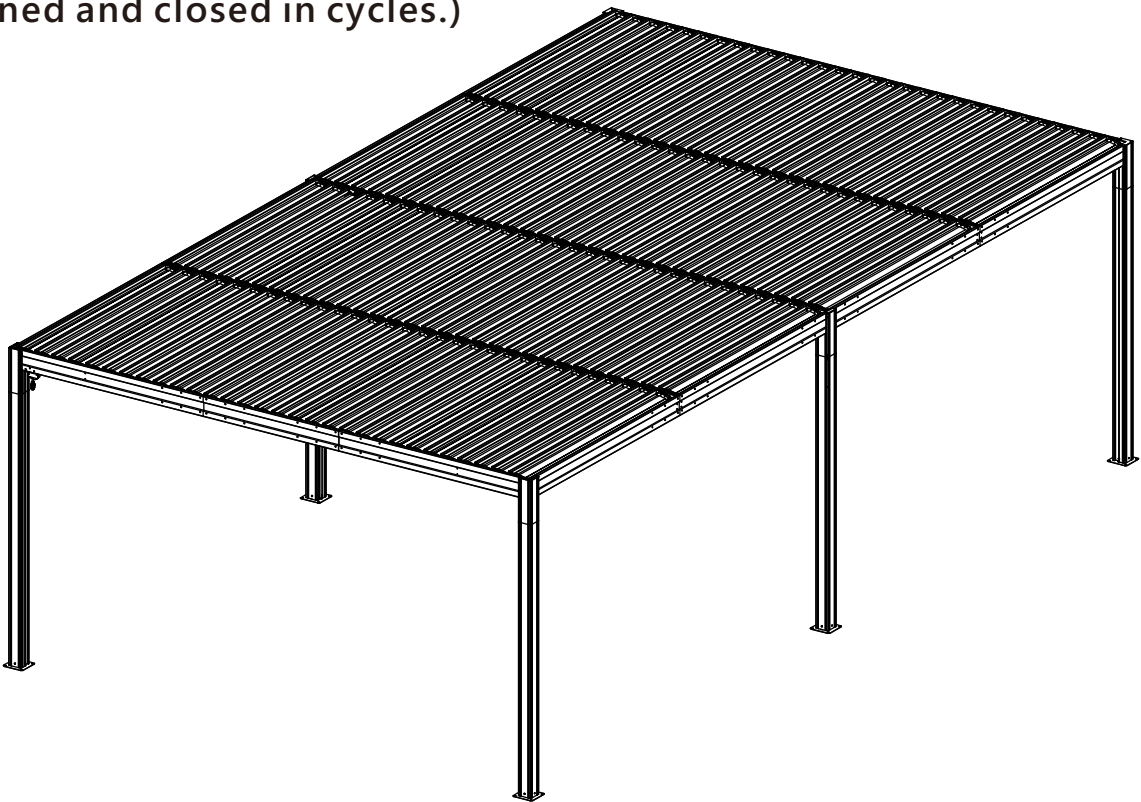

Please confirm the louvers can be fully closed for waterproofness.



Thanks for your purchase.

At domi outdoor living, we believe in our products.

That's why we provide a 12-month warranty and friendly, easy-to-reach after-sales service. So, if you have any questions about our product or assembly, please feel free to contact us. We are here for you.

Support:



After-sales contact email:

service@domioutdoorliving.com

Business cooperation contact email:

marketing@domioutdoorliving.com

Please have your order ID available if you reach out for support.

If you have damaged parts or product, please send us photos for an immediate response.