

## Assembly Instructions

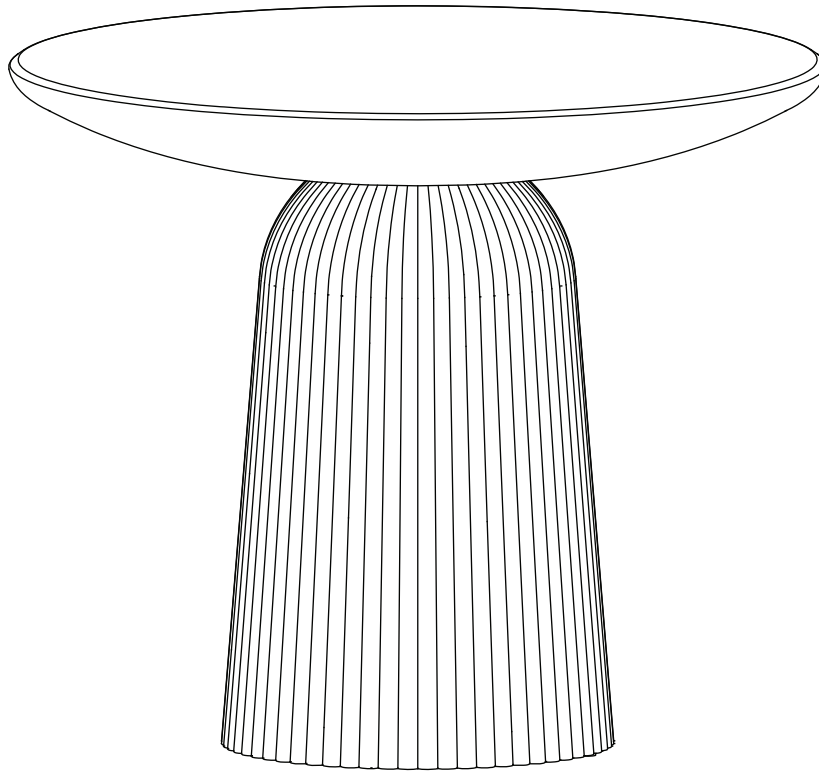

35.5" W x 35.5" D x 29.5" H

## Tools required



### Time to assemble

15 mins

### People to assemble

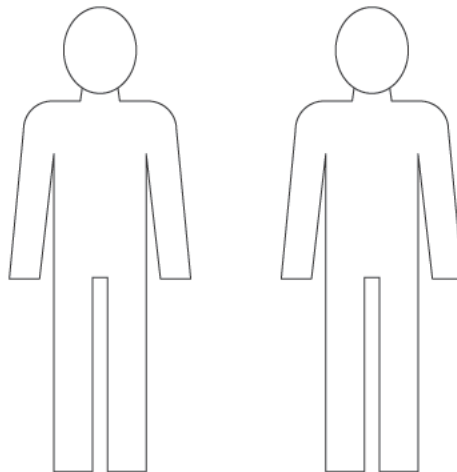

# Important safety information

## Warnings

- ⚠ **This product is not suitable for bedrooms.**
- ⚠ The product should only be used on firm, level ground.
- ⚠ Keep small parts out of reach of children.
- ⚠ Ensure the product is fully assembled as illustrated before use.

## Do's

- ✓ Check the pack and make sure you have all the parts listed.
- ✓ Check all screws or bolts are tightened and inspect regularly.
- ✓ Make sure the legs remain in contact with the ground at all times.

## Don't

- ✗ Do not over tighten screws or bolts.
- ✗ Do not stand on the product.
- ✗ Do not use power tools to construct as overtightening and panel failure may occur.

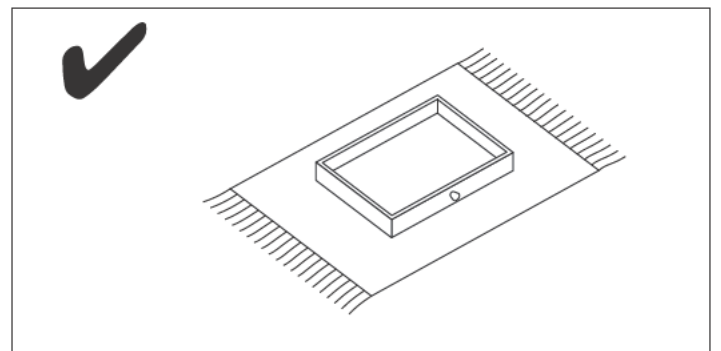
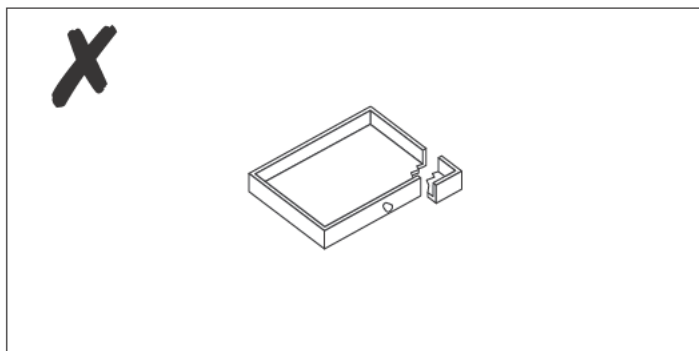
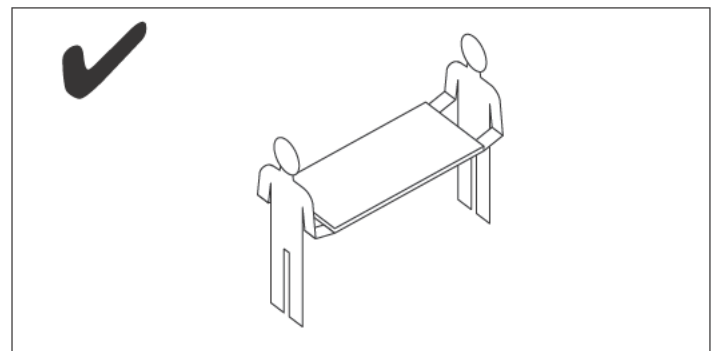
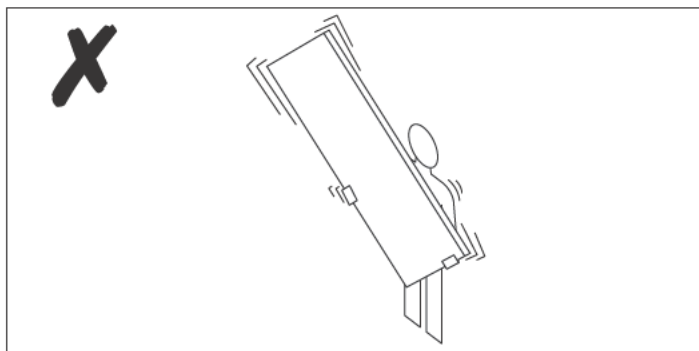
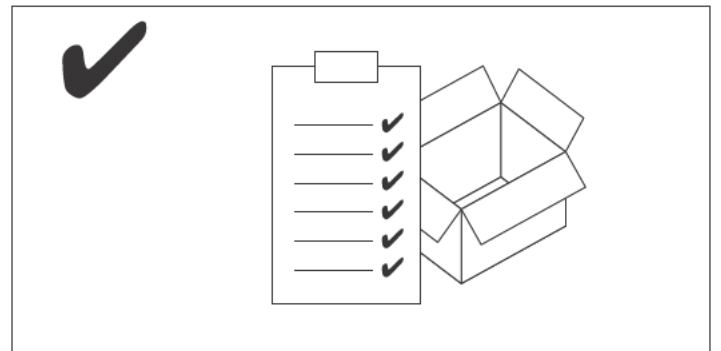
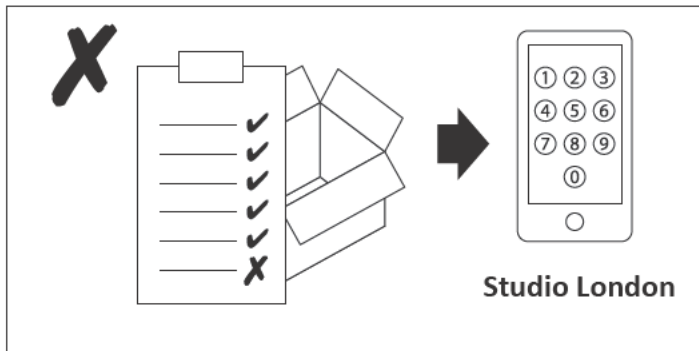

# Your Table

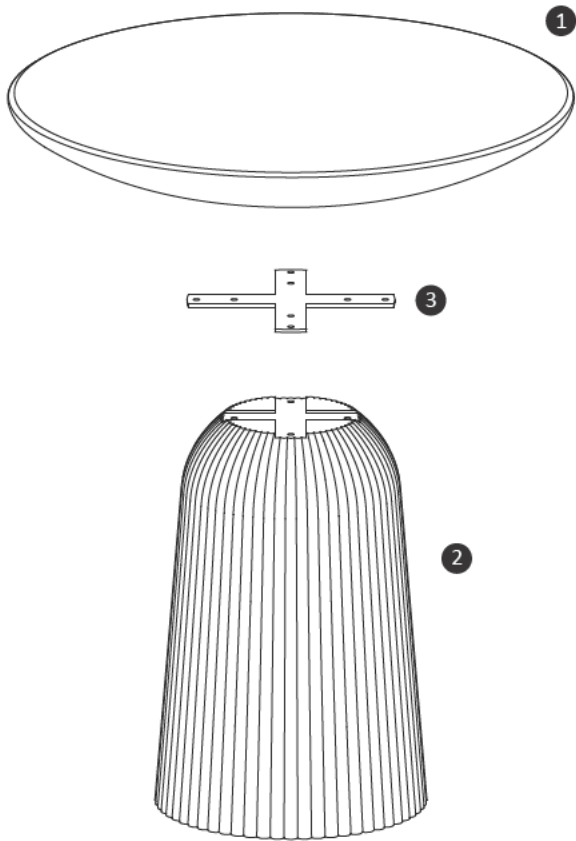

Ref	Description	Dimensions	Qty
①	Table top	35.5" x 35.5" x 5"	1
②	Base	17" x 17" x 25"	1
③	Metal bracket	9.5" x 9.5" x 0.25"	1

# Fixtures and fittings

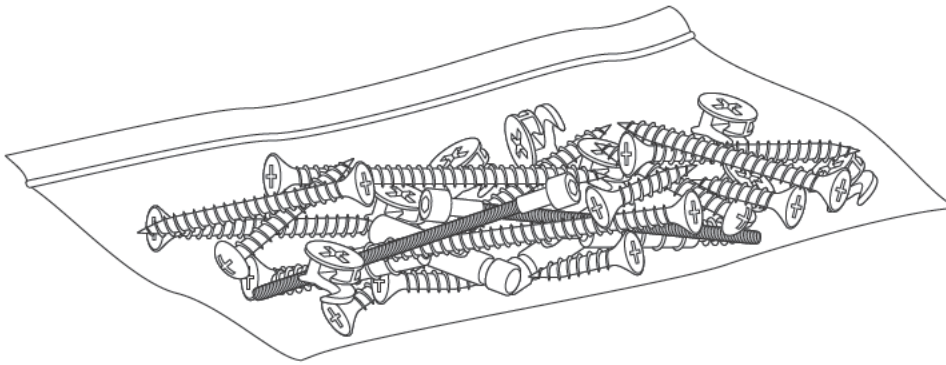

## Fixtures and fittings supplied (actual size)

Ref	Description	Dimensions	Qty	mm
A	Allen bolt	M8 x 20mm	4	

## Fixtures and fittings supplied (not actual size)

Ref	Description	Dimensions	Qty	
B	Allen key	#4	1	

# Product assembly

Maddox Bistro table

## Step 1

1 3 B

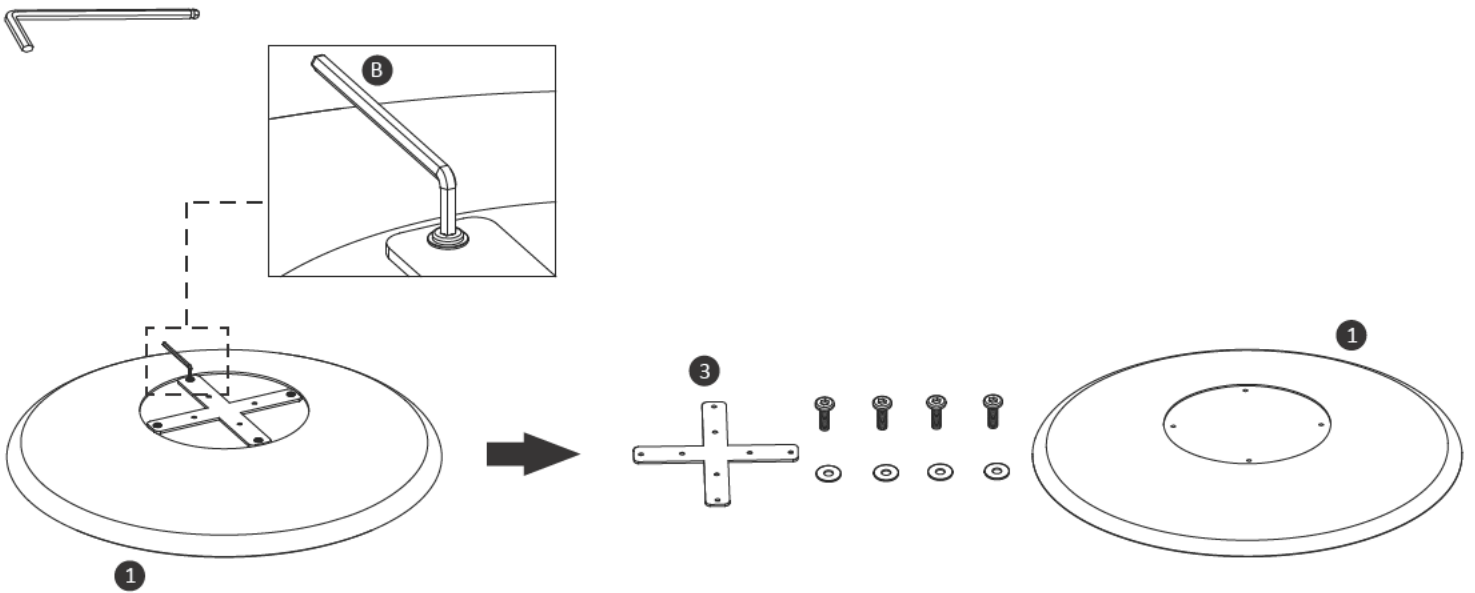

Find a clear area for assembly, near where you intend to use the table. Place the table top (1) upside down on a soft surface. Use the Allen key (B) to un-screw the bolt, remove washer and metal bracket from the table top (1) as shown. Keep the fixtures and fittings aside for the next assembly step.

## Step 2

2 3 A B

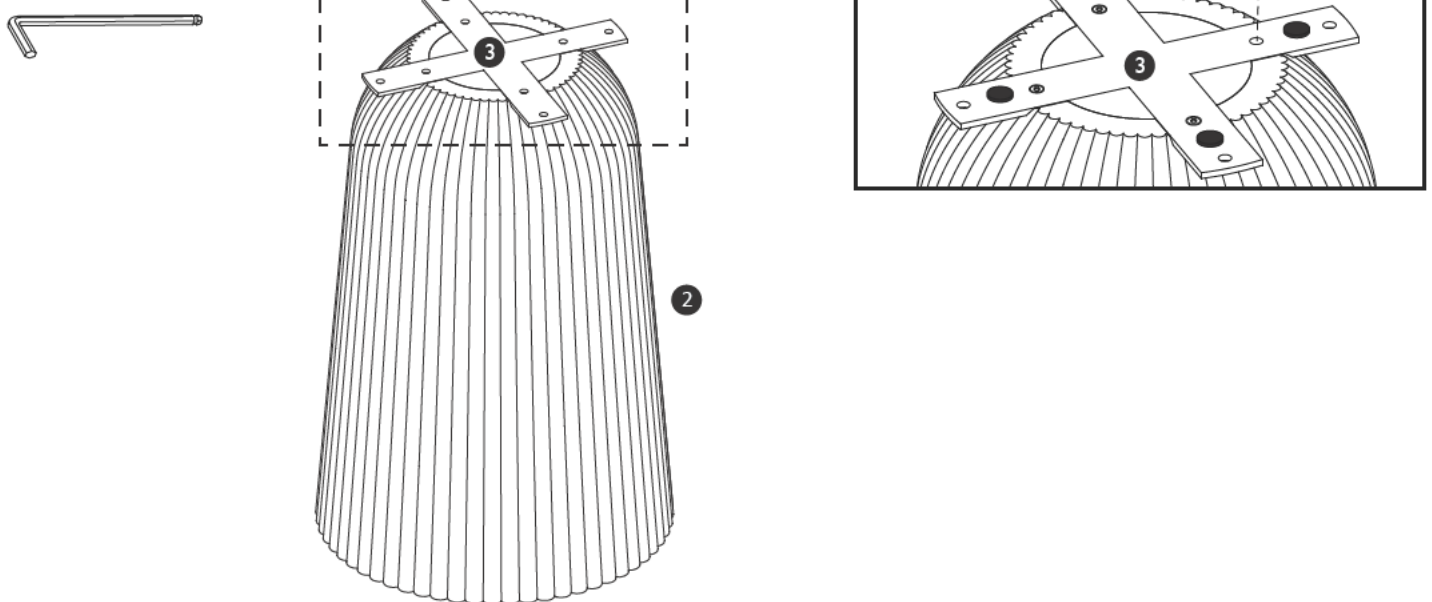

Align the metal bracket (3) with the base (2). Insert Bolt (x1 part A) and tighten with the supplied Allen key (B) as shown.

# Product assembly

Maddox Bistro table

## Step 3

1 2 B

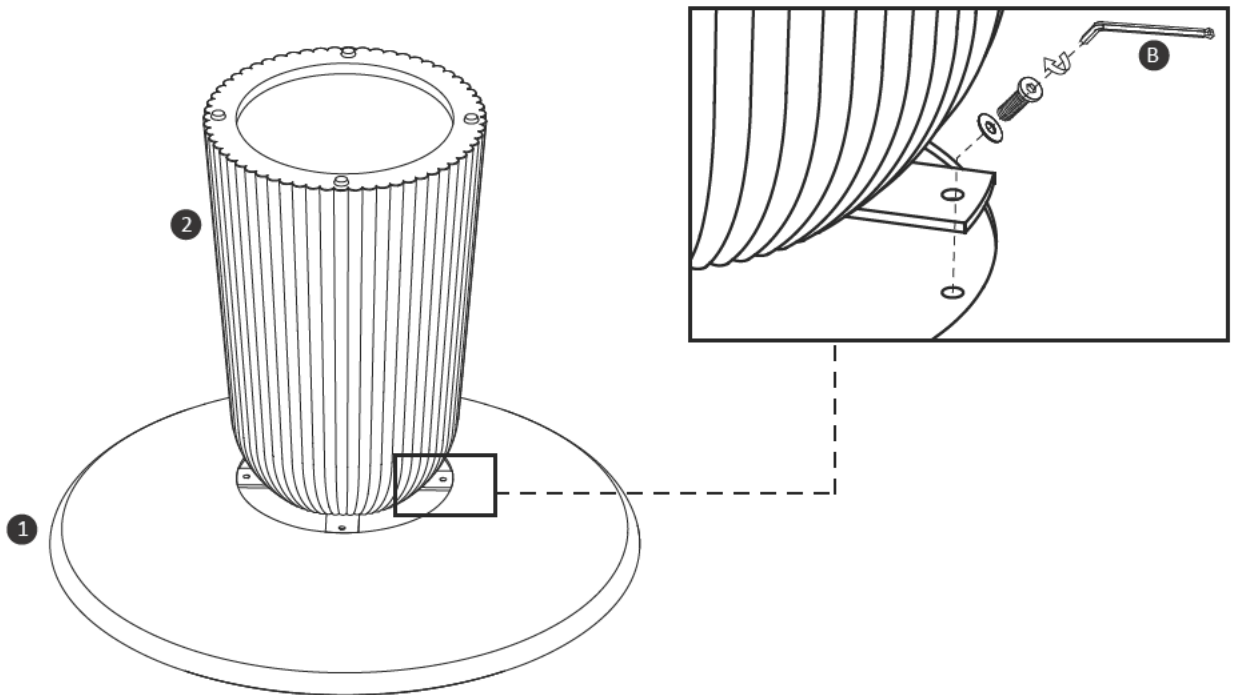

Use the Allen bolt, and washer from step 1 to fix the base to the table top. Tighten with the supplied Allen key (B).

## Step 4

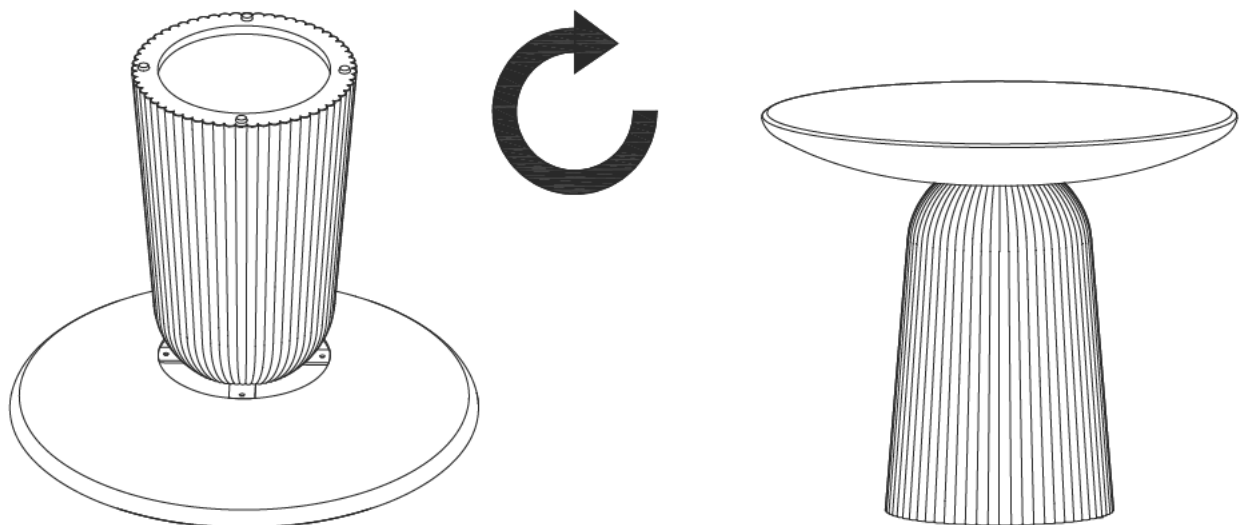

With 2 people, carefully turn over the table by lifting it from the sides of the top.

# Product assembly

Maddox Bistro table

## Step 5

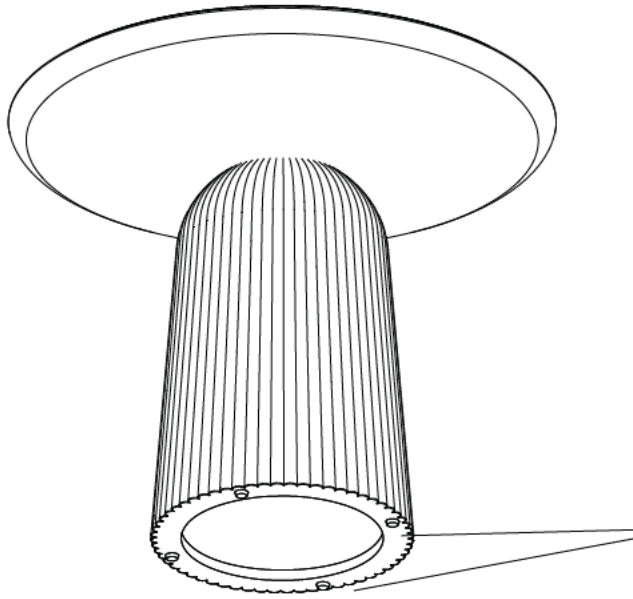

**CAUTION!**  
Please take care when lifting,  
this unit is heavy!  
Please lift by holding the top  
and bottom parts together to  
prevent any damage to the base!

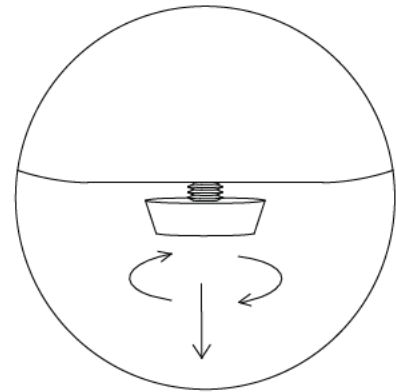

Carefully lift the table and turn the adjustable feet on the base to level the product.

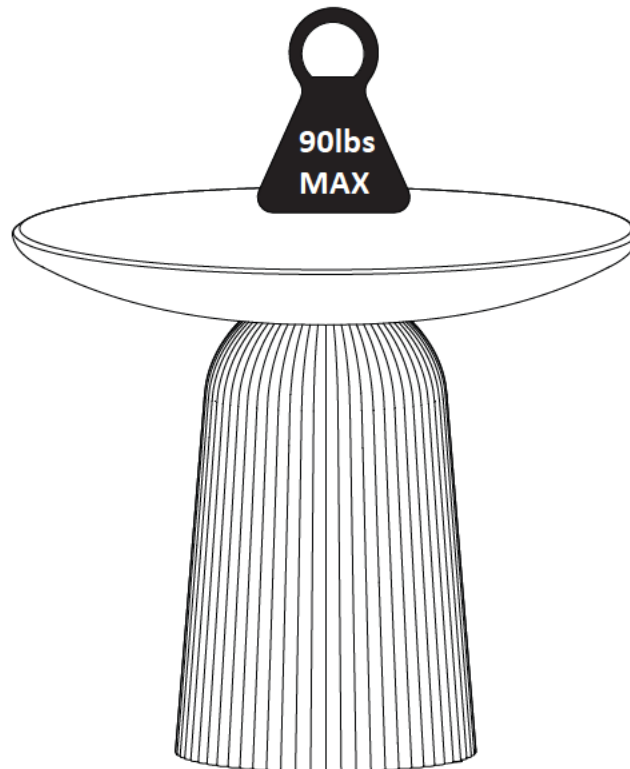

## Maintenance and Care Instructions

### 1. Regular Cleaning

- **Dusting:** Regularly dust the table with a soft, dry cloth to remove surface dust and dirt.
- **Cleaning Solution:** Use a mild detergent mixed with water to clean the table. Avoid harsh chemicals, abrasive cleaners, or acidic substances, as these can damage the surface.
- **Wiping:** Wipe the table with a damp cloth, then immediately dry it with a clean, dry cloth to prevent water spots or streaks.
- **Important:** Do not use a pressure washer, harsh chemicals, or abrasive cleaners.

### 2. Protection

- **Coasters and Placemats:** Use coasters, placemats, or trivets to protect the surface from hot dishes, spills, and scratches.
- **Felt Pads:** Attach felt pads to decorative items, lamps, and other objects to prevent scratching.
- **Avoid Direct Sunlight:** Prolonged exposure to direct sunlight may cause discoloration. Use window treatments to filter UV rays, or keep curtains closed when the table is near windows or glass doors.
- **Moisture:** Wipe away any standing water or other liquids immediately. Prolonged exposure to moisture can cause permanent damage.
- **Ventilation:** Do not place the table near heating or cooling vents (e.g., air conditioners, heaters).
- **Sharp Objects:** Avoid using knives or other sharp tools directly on the surface. Always use a cutting board or plate to prevent damage.

### 3. Sealing

- This table is coated with a top sealant, making it suitable for both indoor and outdoor use. Over time, especially with prolonged outdoor exposure, the surface may become slightly more porous. In such cases, we recommend applying an additional protective sealant suitable for both interior and exterior use.
- **Re-sealing:** Reapply the sealant every 1–2 years, or as directed by the manufacturer, to maintain optimal protection.
- **Type of Sealant:** Use a protective, invisible, matte-finish, siloxane-based sealer such as *Valspar 82092 Clear*. (Note: This is not a product endorsement. Other brands may also be suitable. For professional advice, please consult a reputable DIY store.)

### 4. Stain Removal

- **Immediate Action:** Blot spills immediately with a clean, dry cloth to prevent staining.
- **Stain Removers:** For stubborn stains, use a pH-neutral cleaner specifically designed for stone surfaces. Test on a small, hidden area first to ensure compatibility.

### 5. Outdoor Use

- **Weather Protection:** When used outdoors, protect the table from extreme weather by covering it with a waterproof, UV-resistant cover when not in use.
- **Storage:** If possible, store the table under a covered area during adverse weather conditions.

### Additional Tips

- **Avoid Dragging:** Lift objects rather than dragging them across the table to prevent scratches.
- **Stable Surface:** Ensure the table is placed on a level surface.
- **Seasonal Care:** Adapt your care routine to seasonal changes. For instance, in humid conditions, ensure good ventilation to prevent moisture buildup.
- **Check Fixtures:** Periodically check that all fixtures and fittings are securely tightened.

### Important Safety Information

Ensure the furniture is installed correctly by a qualified person.

We are not liable for any damage or injury resulting from improper installation or assembly.