

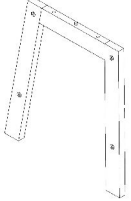

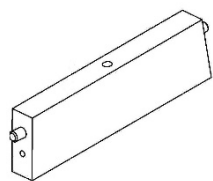
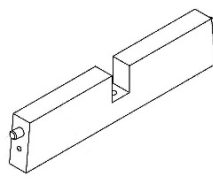
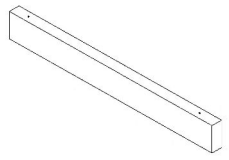
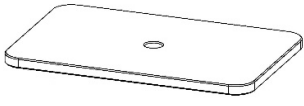

I - PARTS AND HARDWARE

A - 2 Pcs 	B - 2 Pcs 	C - 2 Pcs 	D - 1 Pcs 
E - 1 Pcs 	F - 8 Pcs  Screw M6x40	G - 8 Pcs  Screw M4x35	H - 1 Pcs  Allen key 4

II - PRODUCT ASSEMBLY, ***DO NOT tighten the screws until all of parts set into correct position!**

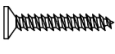
STEP 1. Fix Part (A)x1 with Part (B)x2 by using Screws (F)x2 with Allen Key (H)

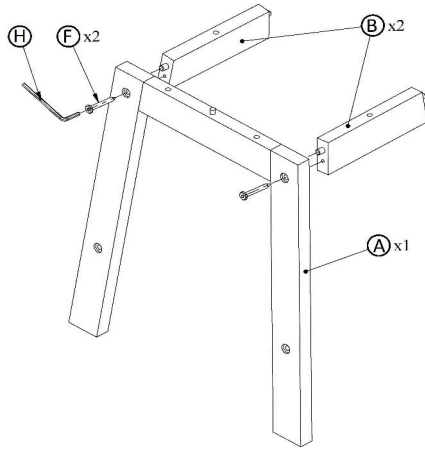

STEP 2. Fix Part (A) with Part (C)x2 by using Screws (F)x2 with Allen Key (H)

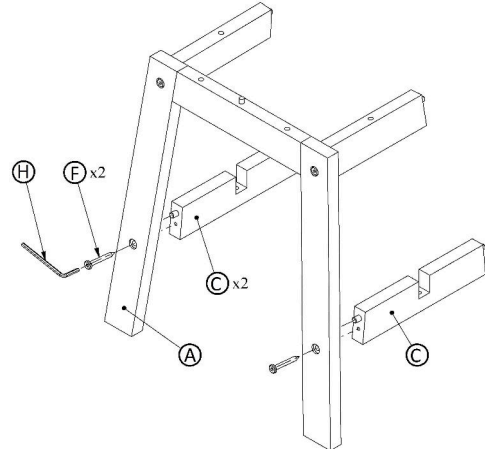

STEP 3. Fix Part (A)x1 with Part (B) (C) by using Screws (F)x4 with Allen Key (H)

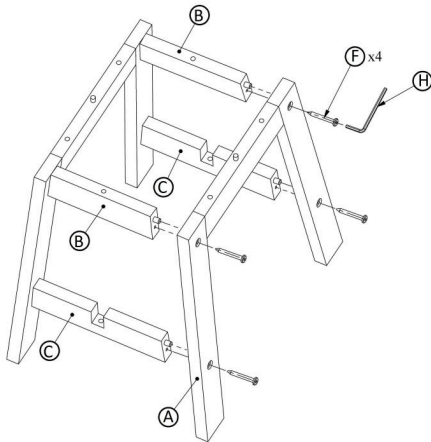

STEP 4. Fix Part (D)x1 with Part (C) by using Screws (G)x2 with Screwdriver

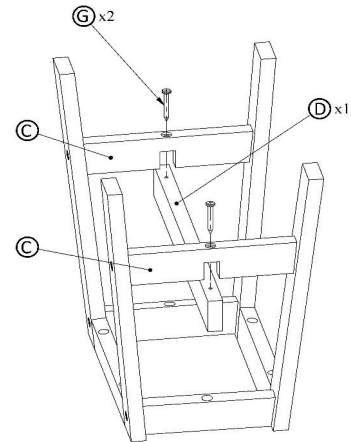

STEP 5. Fix Part (E)x1 with Part (A) (B) by using Screws (G)x6 with Screwdriver

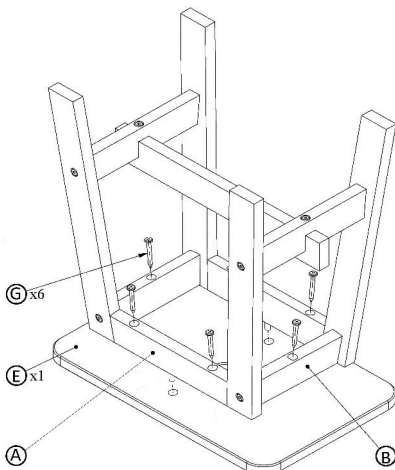

FINISH

