

IMPORTANT PLEASE FOLLOW !

After unpacking the product, keep the original packaging in case you need to return it. Before starting assembly, check that all parts and hardware are included and in good condition. If anything is missing or damaged, contact the supplier or retailer. **Do not use** non-original parts, modify the item or use power tools as this will void the warranty. Study the instructions thoroughly and follow each step carefully before proceeding to the next.

TESSA 4 DOOR MIRRORED WARDROBE NATURAL OAK EFFECT ASSEMBLY INSTRUCTIONS



15KG
LARGE SHELF
MAX WEIGHT



10KG
SMALL SHELF
MAX WEIGHT



12KG
HANGING RAIL
MAX WEIGHT



7KG
MAX DRAWER
WEIGHT

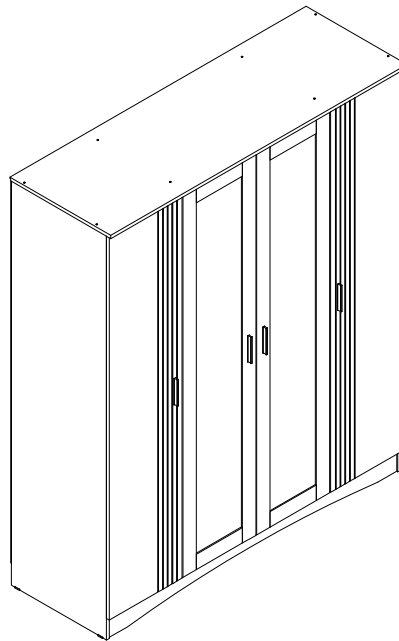

**FOR DOMESTIC USE ONLY
FURNITURE CARE AND MAINTENANCE
PLEASE READ BEFORE YOU CONTINUE FURTHER**

Safety

- Keep children away from the area during assembly for safety.
- Use a blanket or sheet on the floor during assembly to protect both the product and your flooring.
- Attach the Anti-Tip strap shown on the final step to the wall. This will prevent the item from tipping over and causing damage or serious injury.
- Follow all recommended weight limits as shown on the assembly instructions.

Care

- Avoid dragging or pushing the product, as this may damage the joints and weaken the structure.
- Avoid prolonged exposure to direct sunlight, which can cause fading, discolouration, or drying of natural wood.
- Maintain stable room temperature and humidity, as extreme heat, cold, or moisture may lead to warping, cracking, or swelling.
- Protect the surface from hot or cold items by using placemat's or coasters.
- Please avoid attaching anything sticky to the item, such as Sellotape, stickers, or similar materials, as this can damage the finish.
- Use felt pads under décor, lamps and accessories to prevent scratches.
- Clean spills immediately, blotting rather than rubbing to prevent spreading and surface damage.

Maintenance

- Periodically tighten all fittings to ensure the furniture remains stable and secure.
- Use only a damp cloth followed by a dry cloth for routine cleaning - avoid detergents, solvents and chemical cleaner.

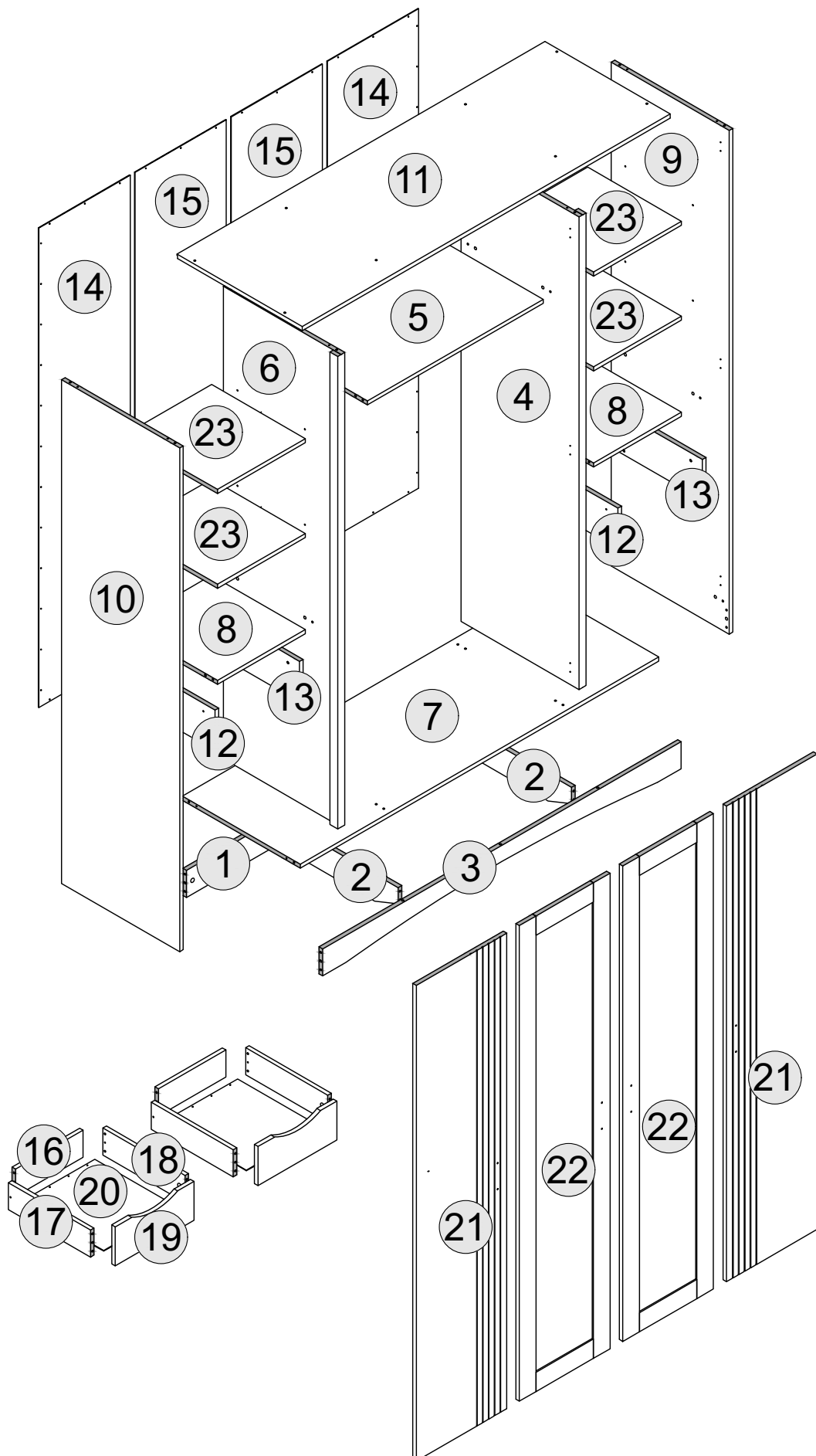

PART LIST

Carton 1 of 4

Part Number	Part Code	Part Description	Quantity	Carton
1	S100-101-275-EU1-01	Back Leg	1	1/4
3	S100-101-275-EU1-03	Front Leg	1	1/4
9	S100-101-275-EU1-09	Side Panel - Right	1	1/4
10	S100-101-275-EU1-10	Side Panel - Left	1	1/4
14	S100-101-275-EU1-14	Back Panel 1	2	1/4
15	S100-101-275-EU1-15	Back Panel 2	2	1/4
20	S100-101-275-EU1-20	Drawer Base	2	1/4

Carton 2 of 4

2	S100-101-275-EU1-02	Centre Leg	2	2/4
7	S100-101-275-EU1-07	Bottom Panel	1	2/4
8	S100-101-275-EU1-08	Small Shelf Panel	2	2/4
11	S100-101-275-EU1-11	Top Panel	1	2/4
16	S100-101-275-EU1-16	Drawer Back	2	2/4
19	S100-101-275-EU1-19	Drawer Front	2	2/4
23	S100-101-275-EU1-23	Shelf Panel	4	2/4



















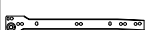

Carton 3 of 4

4	S100-101-275-EU1-04	Centre Panel - Right	1	3/4
5	S100-101-275-EU1-05	Large Shelf Panel	1	3/4
6	S100-101-275-EU1-06	Centre Panel - Left	1	3/4
12	S100-101-275-EU1-12	Drawer Support - Left	2	3/4
13	S100-101-275-EU1-13	Drawer Support - Right	2	3/4
17	S100-101-275-EU1-17	Drawer Side - Left	2	3/4
18	S100-101-275-EU1-18	Drawer Side - Right	2	3/4

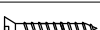
Carton 4 of 4

21	S100-101-275-EU1-21	Doors	2	4/4
22	S100-101-275-EU1-22	Mirrored Doors	2	4/4

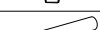
HARDWARE LIST

A		DOWEL 6 X 30MM	58 PCS
B		CAM BOLT + CAM NUT	34 SETS
C		SCREW M6 X 50MM	12 PCS
D		SCREW M3.5 X 16MM	45 PCS
E		TACK	59 PCS
F		SCREW M4 X 25MM	24 PCS
G		HANDLE	4 PCS
H		TAPPING SCREW M8 X 12MM	24 PCS
I		ALLEN KEY	1 PC
J		SHELF SUPPORT	16 PCS
K		HINGES 5/8	12 PCS
L		STOPPER	1 PC
M		DRAWER RUNNER A - L/R	4 PCS
N		DRAWER RUNNER B - L/R	4 PCS
O		SCREW M4 X 38MM	4 PCS
P		SCREW M3.5 X 12MM	20 PCS
Q		PLASTIC H STRIP	3 PCS
R		PLASTIC FOOT	8 PCS
S		HANGING RAIL SUPPORT	2 PCS
T		HANGING RAIL	1 PC
U		ANTI - TIP STRAP	2 PCS
V		SCREW M4 X 16MM	2 PCS

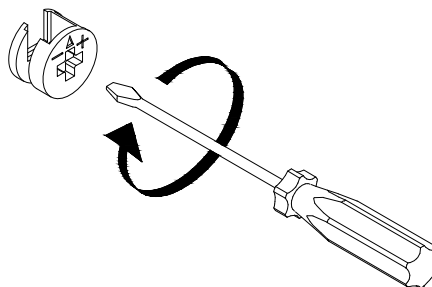

(SCREWDRIVER NOT PROVIDED)

USE A FLAT HEAD SCREWDRIVER TO TIGHTEN THE CAM NUTS. A QUARTER TURN CLOCKWISE IS ALL THAT IS NEEDED.

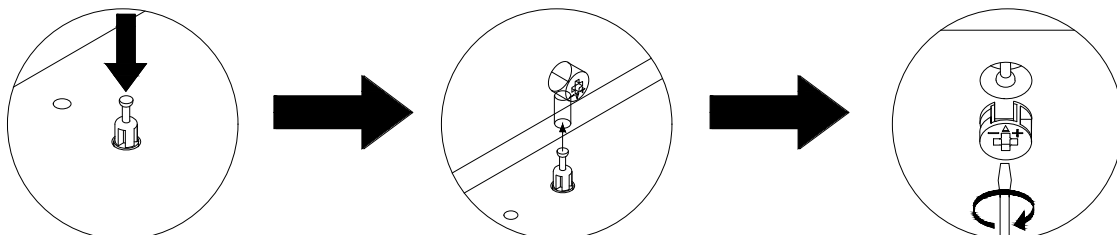

STEP 1 - PUSH CAM BOLT INTO INSERT

STEP 2 - ALIGN THE CAM BOLT WITH THE HOLE AND PUSH TOGETHER UNTIL FLUSH. (MAKE SURE THE ARROW OF THE CAM LOCK IS POINTING TOWARD ON THE EDGE OF THE PANEL.)



STEP 3 - THE HEAD OF THE BOLT GOES INTO THE WIDE MOUTH OF THE CAM LOCK. YOU THEN TURN THE LOCK SO THE NARROW PART CLOSES OVER THE BOLT.

STEP 1

PARTS REQUIRED

1 - BACK LEG	x1
2 - CENTRE LEG	x2
3 - FRONT LEG	x1

HARDWARE REQUIRED

A		14
B		04
B		14

TOOLS REQUIRED

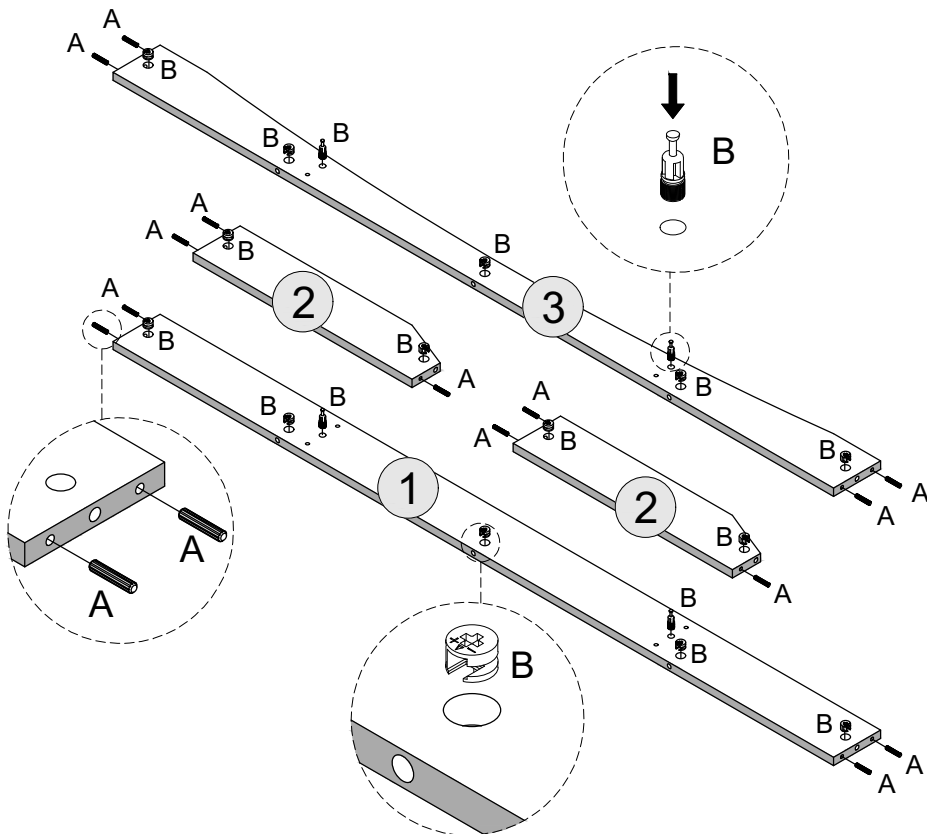
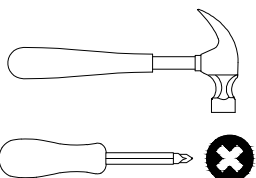





STEP 2

PARTS REQUIRED

5 - LARGE SHELF PANEL	x1
7 - BOTTOM PANEL	x1
8 - SMALL SHELF PANEL	x2
11 - TOP PANEL	x1

HARDWARE REQUIRED

A		16
B		16
D		01
L		01

TOOLS REQUIRED

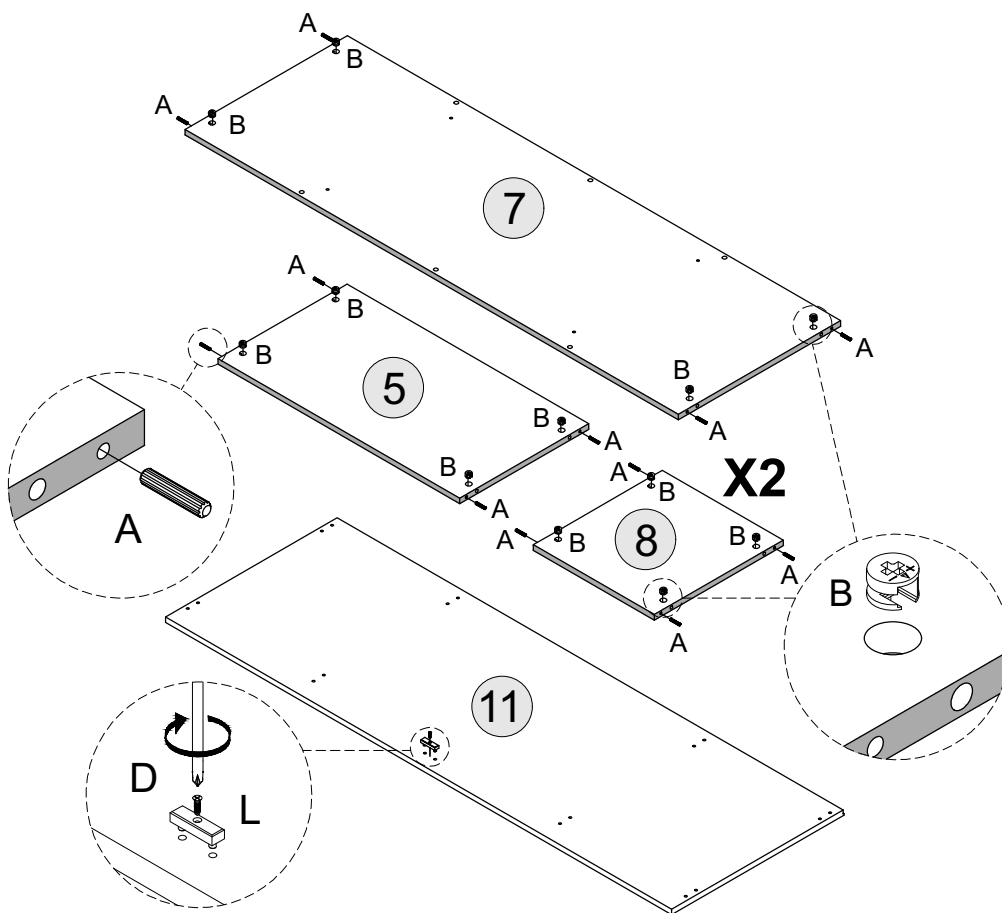
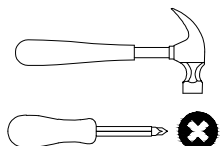





STEP 3

PARTS REQUIRED

4 - CENTRE PANEL - RIGHT x1

HARDWARE REQUIRED

A		04
B		04
J		04
P		02
S		01

TOOLS REQUIRED

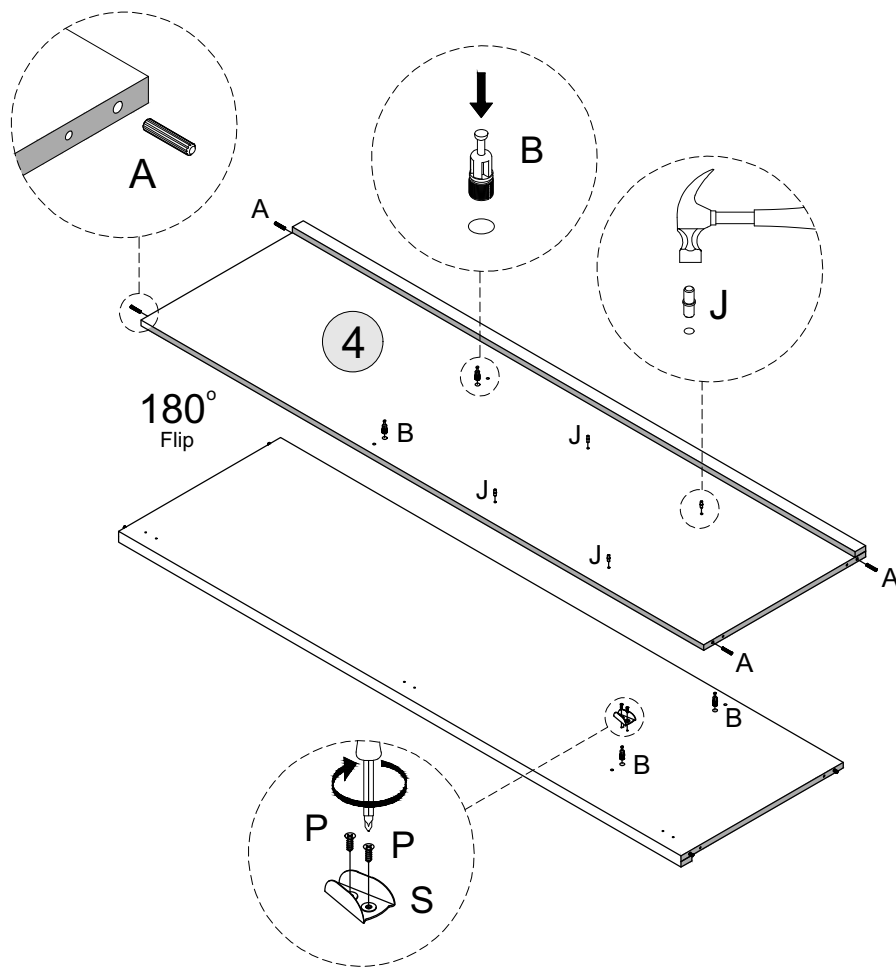
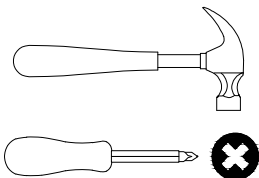





STEP 4

PARTS REQUIRED

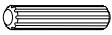
6 - CENTRE PANEL - LEFT x1

HARDWARE REQUIRED

A		04
B		04
J		04
P		02
S		01

TOOLS REQUIRED

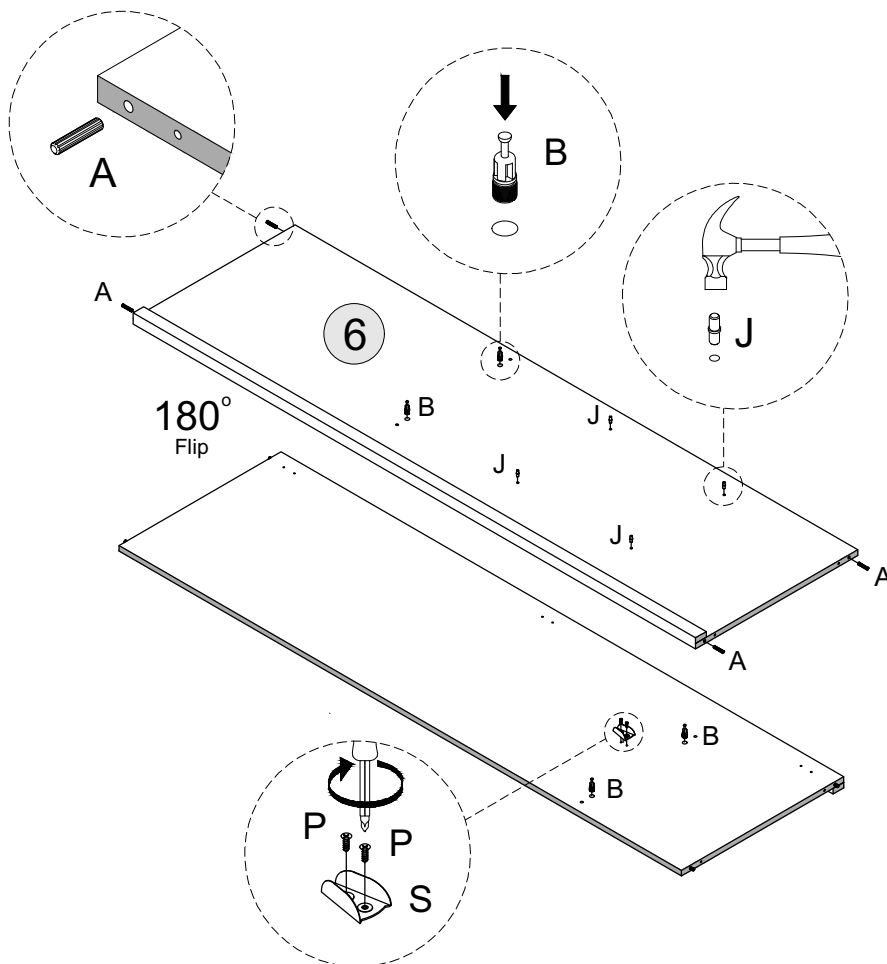
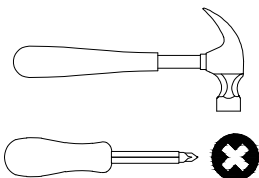



STEP 5

PARTS REQUIRED

9 - SIDE PANEL - RIGHT	x1
10 - SIDE PANEL - LEFT	x1

HARDWARE REQUIRED

A		04
B		12
J		08

TOOLS REQUIRED

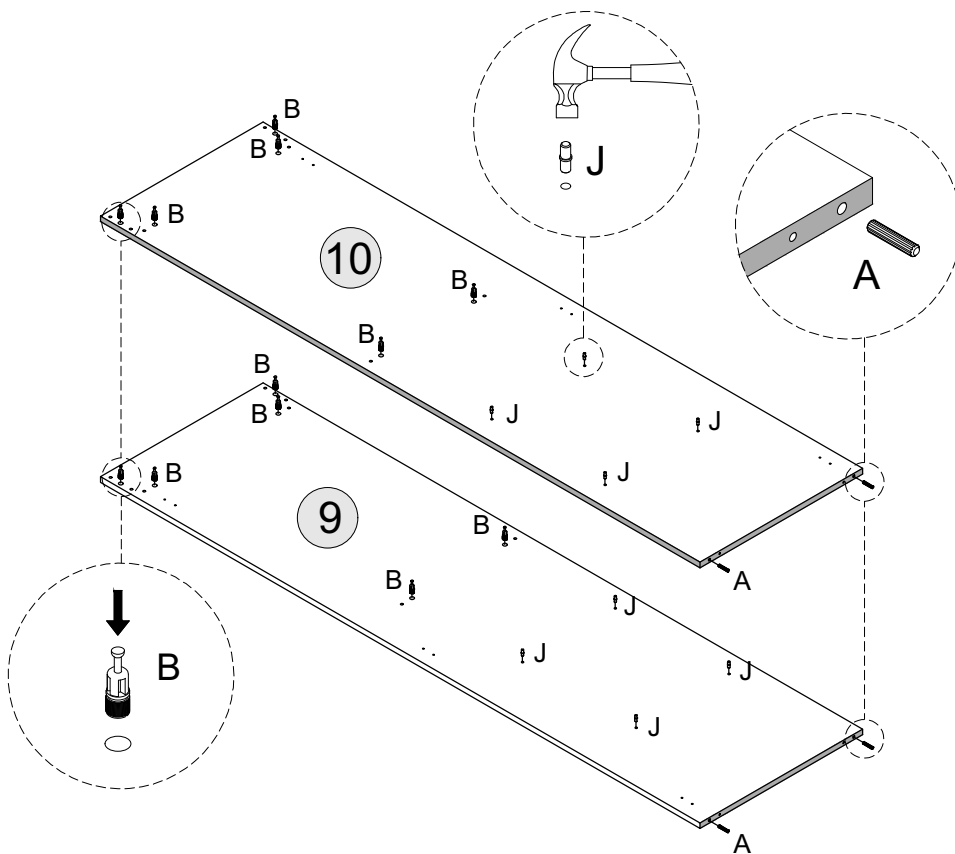
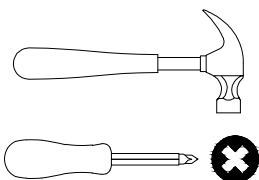

STEP 6

PARTS REQUIRED

1 - BACK LEG	x1
2 - CENTRE LEG	x2
3 - FRONT LEG	x1

HARDWARE REQUIRED

TOOLS REQUIRED

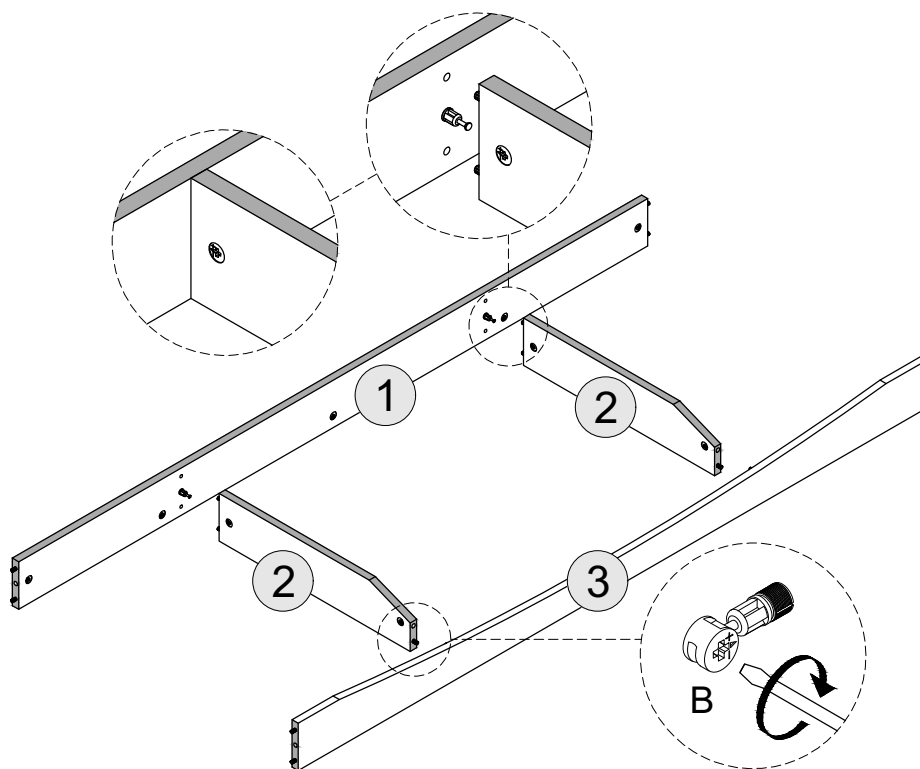
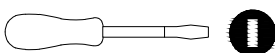

STEP 7

PARTS REQUIRED

- 4 - CENTRE PANEL - RIGHT x1
- 5 - LARGE SHELF PANEL x1
- 6 - CENTRE PANEL - LEFT x1

HARDWARE REQUIRED

TOOLS REQUIRED

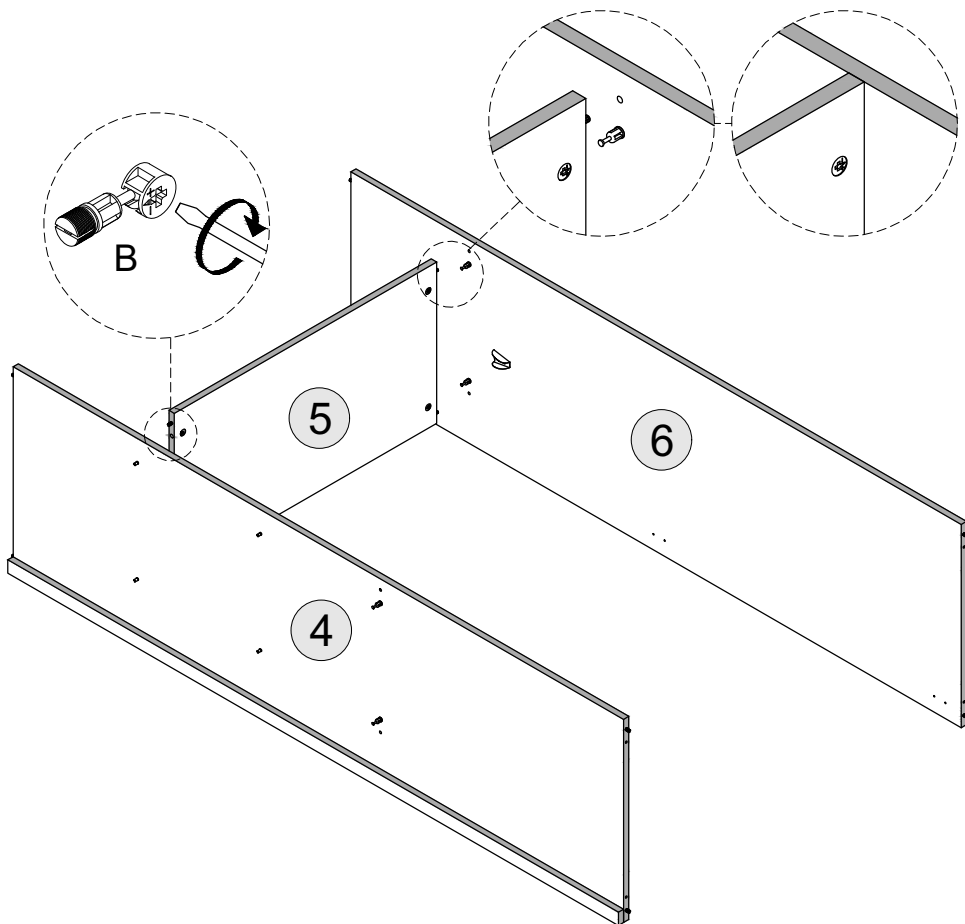

STEP 8

PARTS REQUIRED

- 7 - BOTTOM PANEL x1

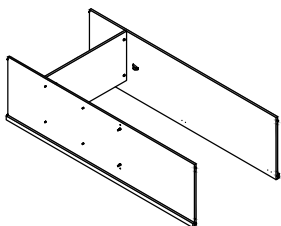

HARDWARE REQUIRED

- C 04

TOOLS REQUIRED

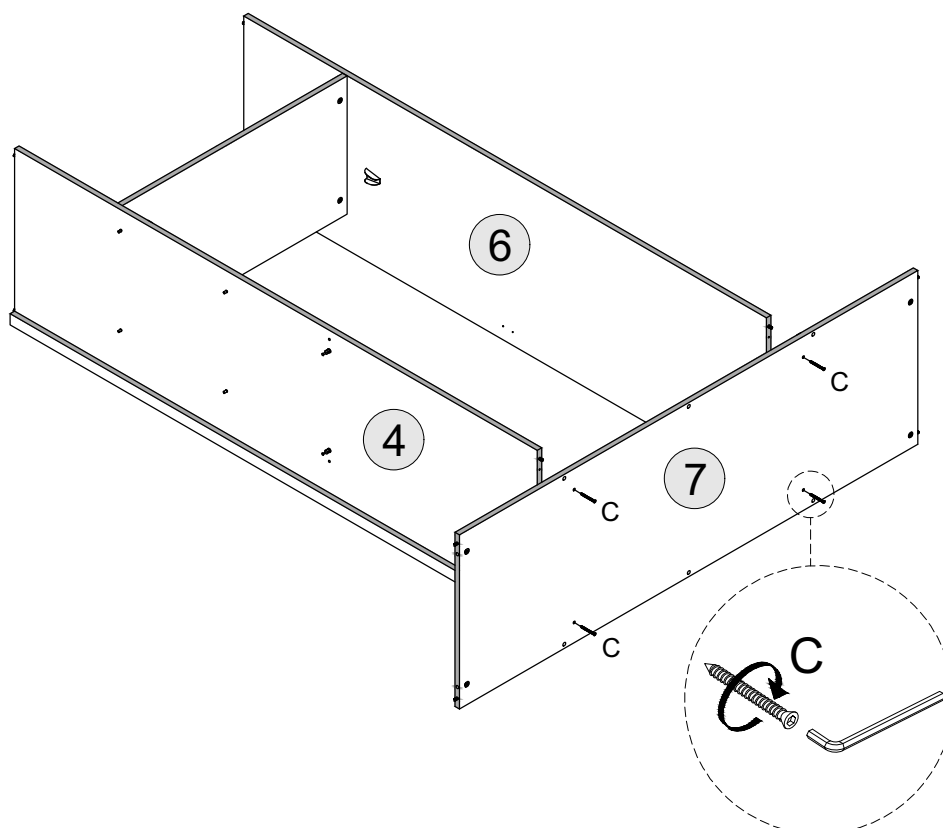

STEP 9

PARTS REQUIRED

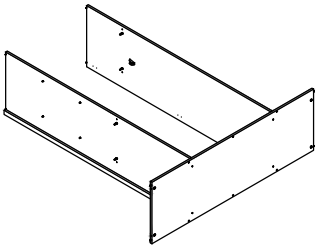

HARDWARE REQUIRED



TOOLS REQUIRED

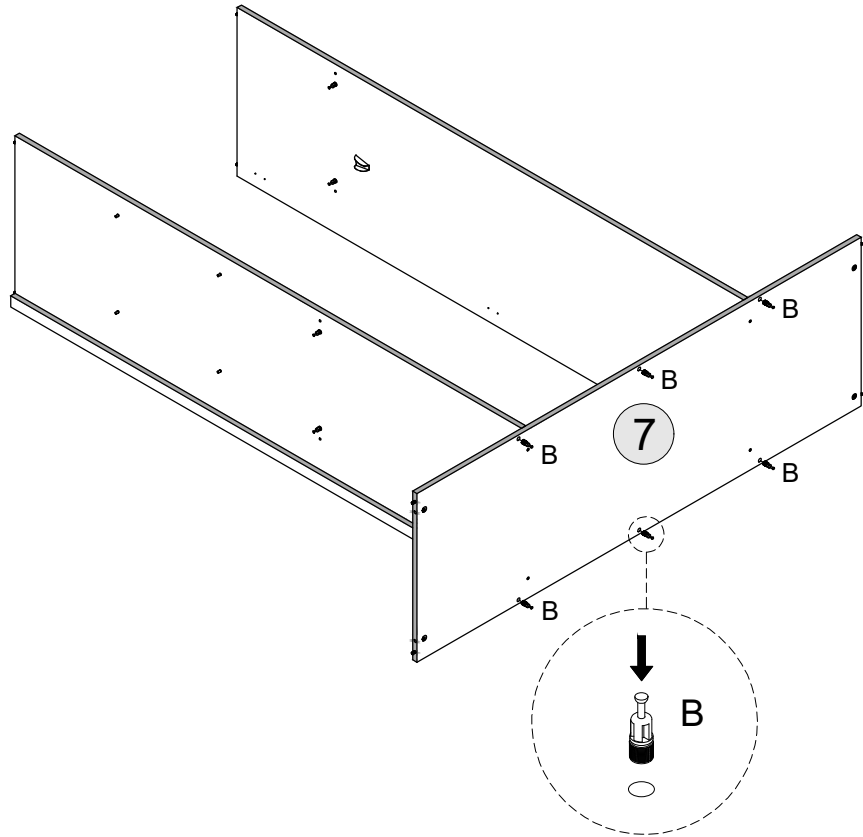

STEP 10

PARTS REQUIRED

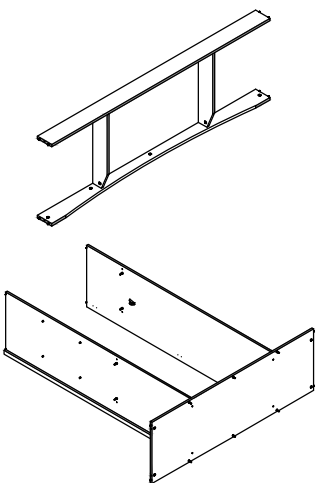

HARDWARE REQUIRED

TOOLS REQUIRED

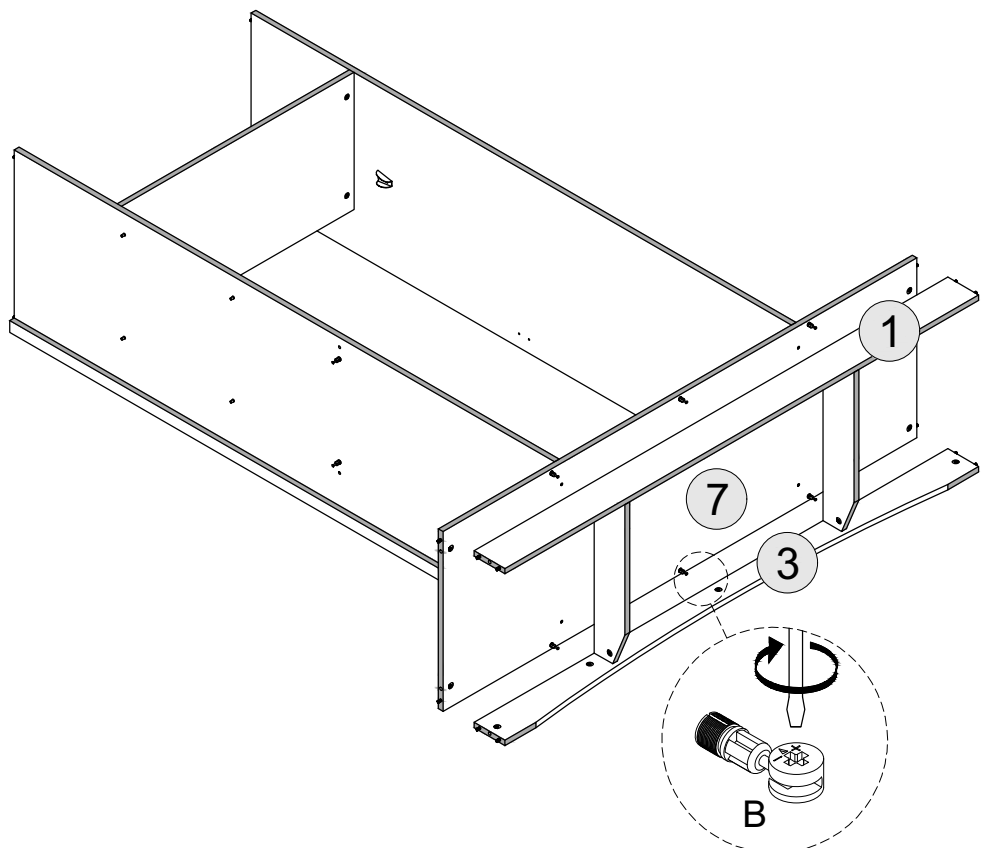
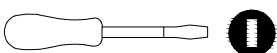

STEP 11

PARTS REQUIRED

8 - SMALL SHELF PANEL x1

9 - SIDE PANEL - RIGHT x1

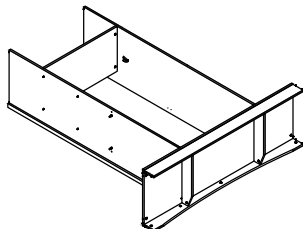

HARDWARE REQUIRED

TOOLS REQUIRED

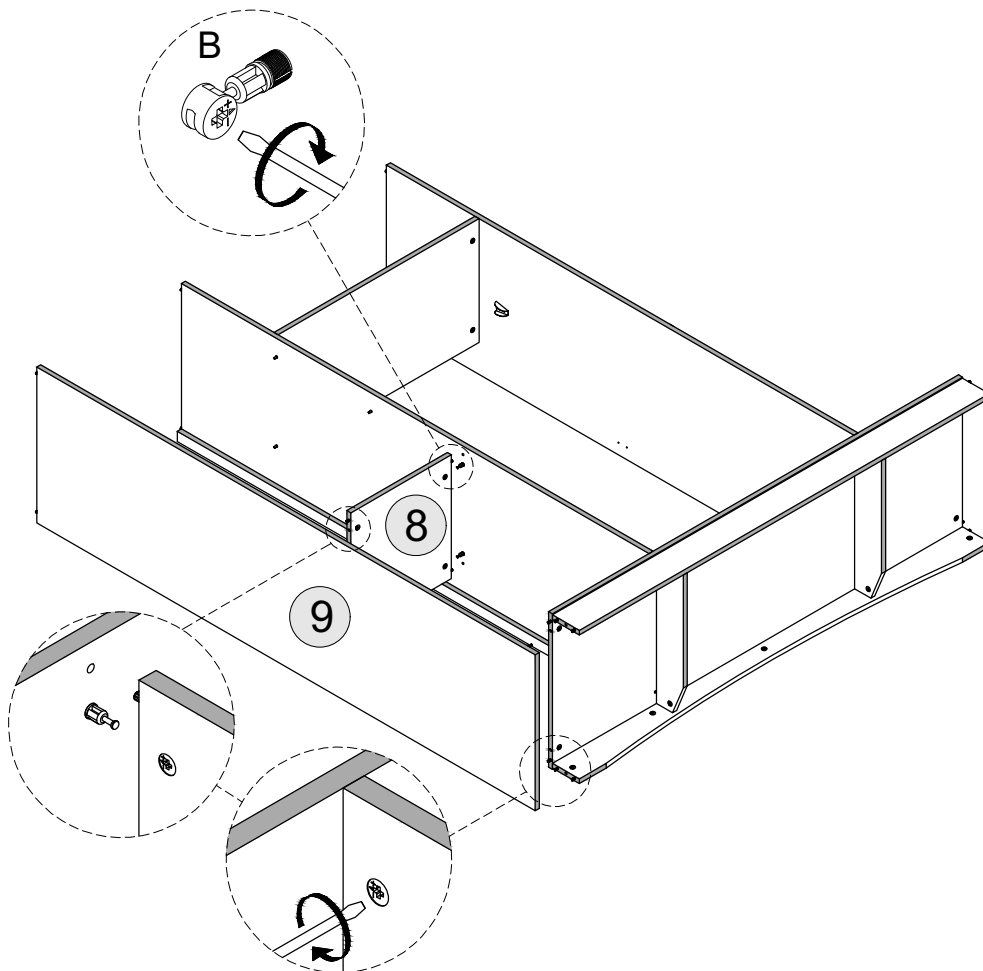
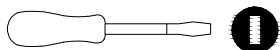

STEP 12

PARTS REQUIRED

8 - SMALL SHELF PANEL x1

10 - SIDE PANEL - LEFT x1

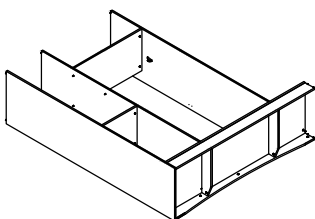

HARDWARE REQUIRED

TOOLS REQUIRED

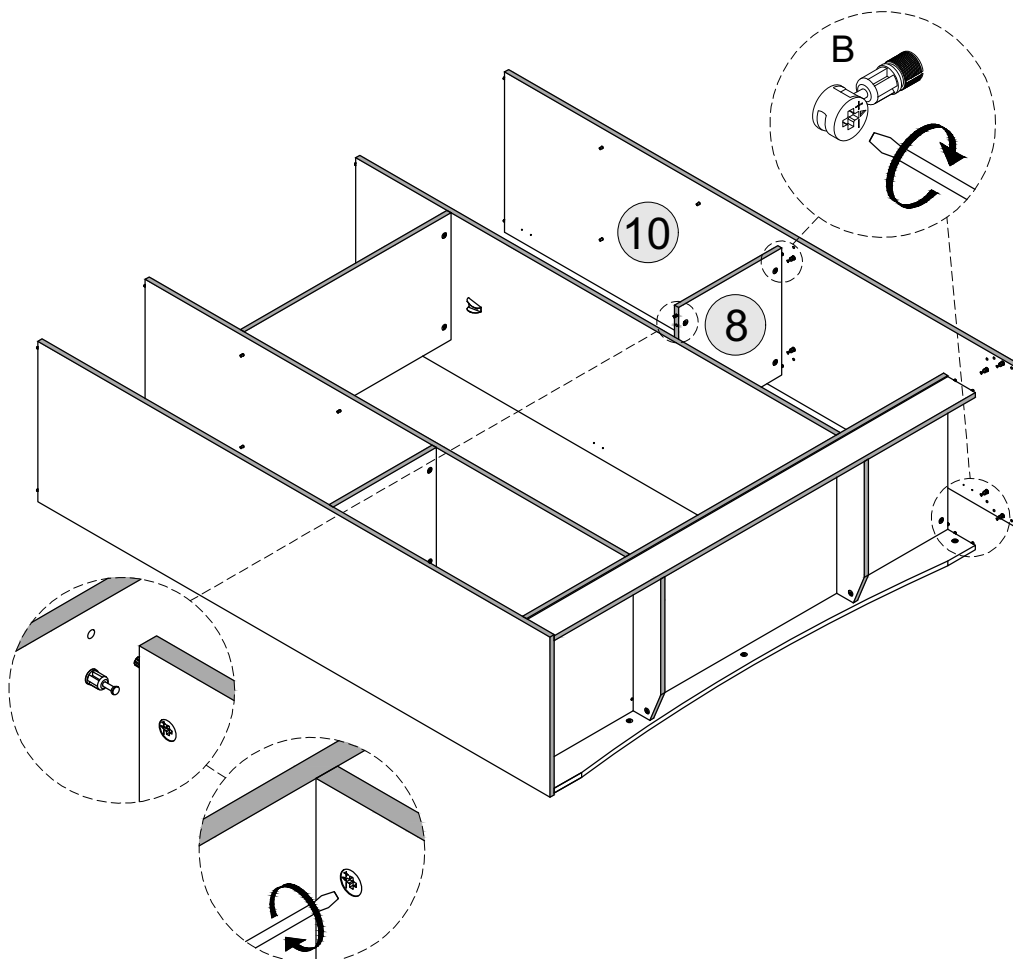
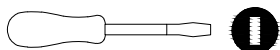

STEP 13

PART REQUIRED

11 - TOP PANEL x1

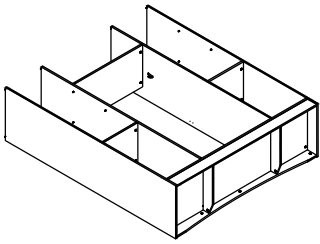

HARDWARE REQUIRED

C  08

TOOLS REQUIRED

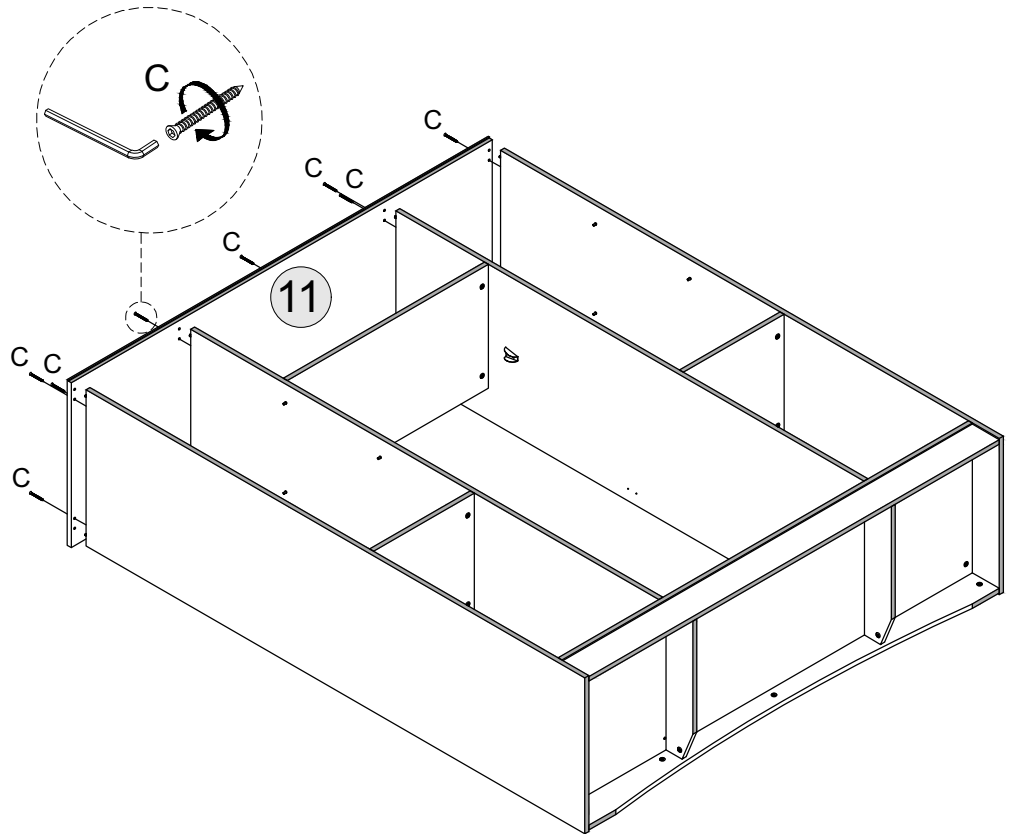

STEP 14

PARTS REQUIRED

12 - DRAWER SUPPORT - LEFT x2

13 - DRAWER SUPPORT - RIGHT x2

HARDWARE REQUIRED

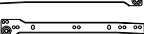
M  04

P  16

TOOLS REQUIRED

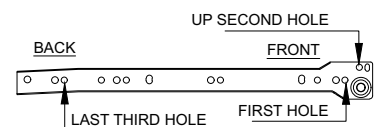
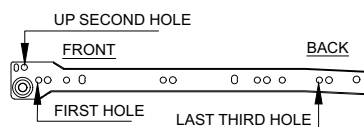
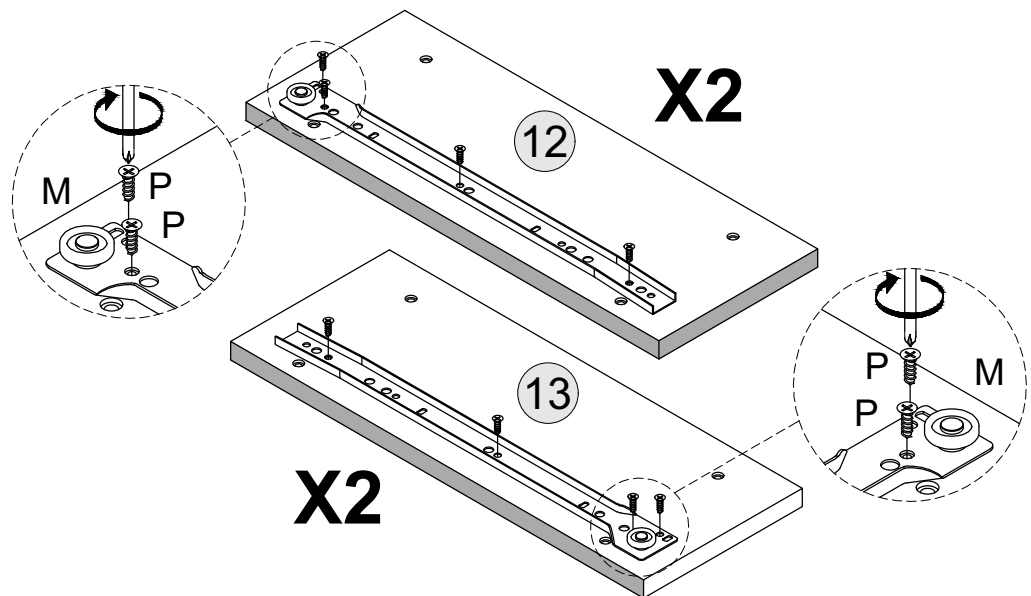
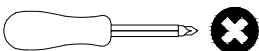

STEP 15

PART REQUIRED

12 - DRAWER SUPPORT - LEFT x2

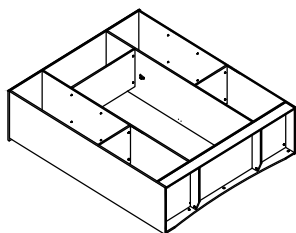

HARDWARE REQUIRED

F  08

TOOLS REQUIRED

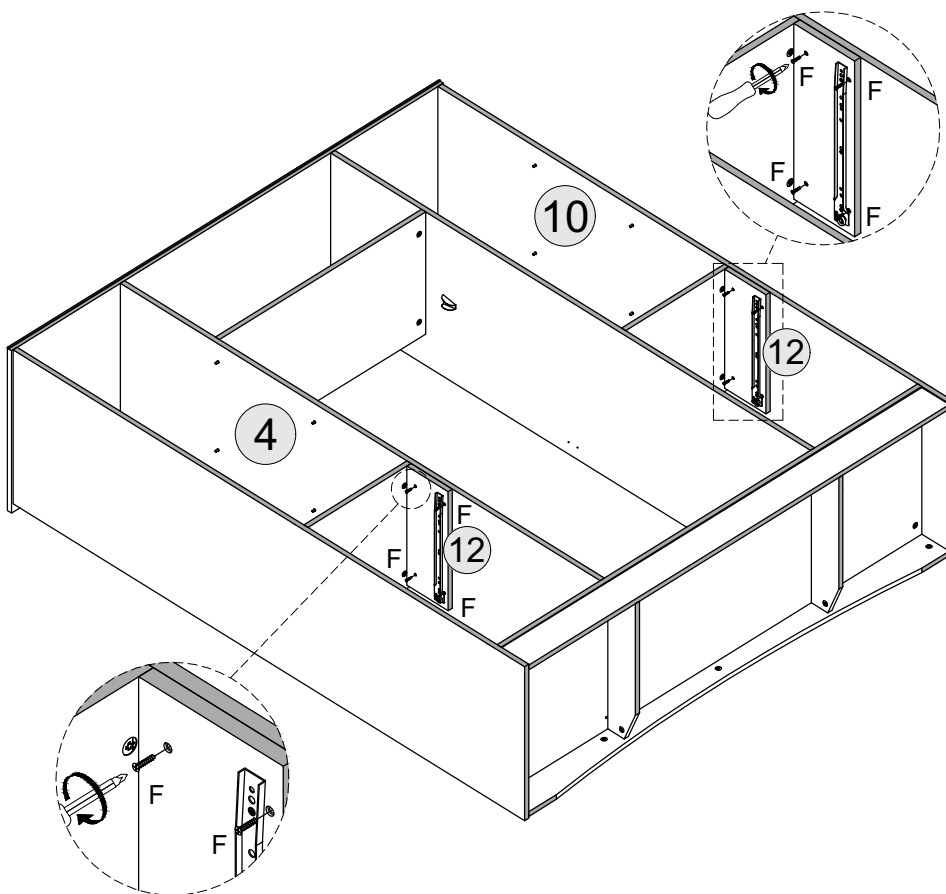
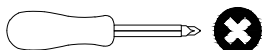

STEP 16

PARTS REQUIRED

13 - DRAWER SUPPORT - RIGHT x2

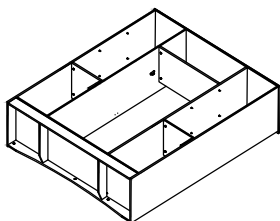

HARDWARE REQUIRED

F  08

TOOLS REQUIRED

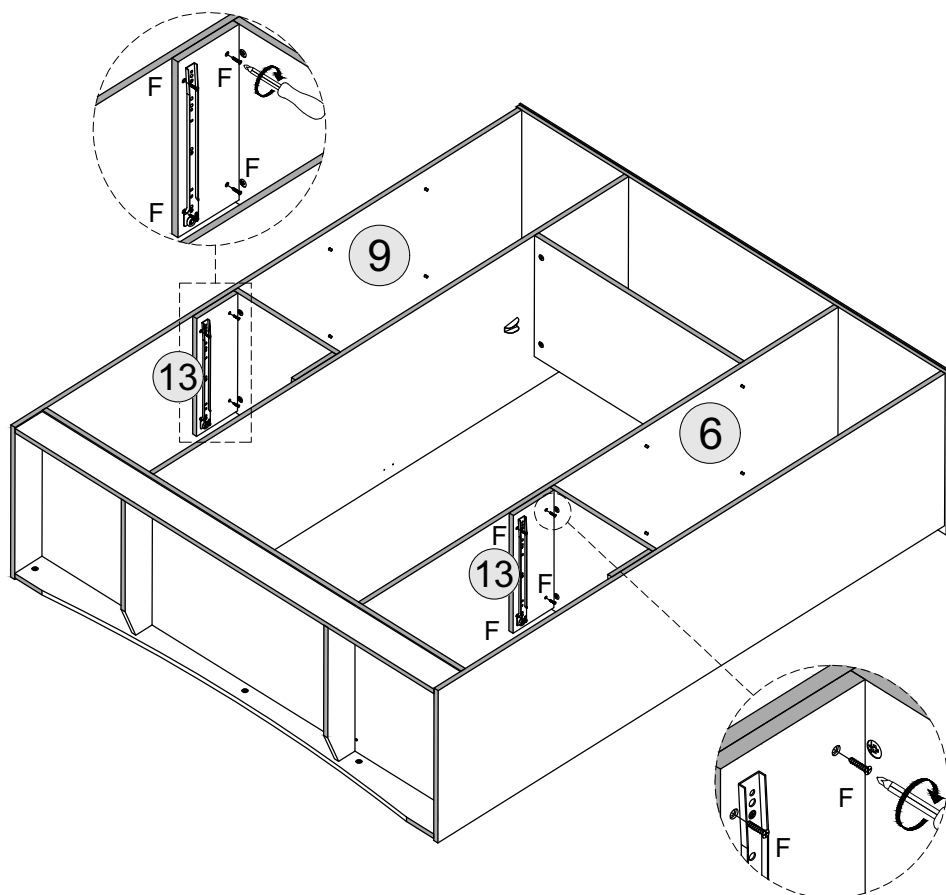
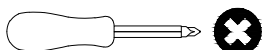

STEP 17

PART REQUIRED

14 - BACK PANEL I	x2
15 - BACK PANEL II	x2

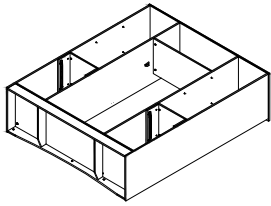

HARDWARE REQUIRED

D		08
E		51
Q		03
R		08

TOOLS REQUIRED

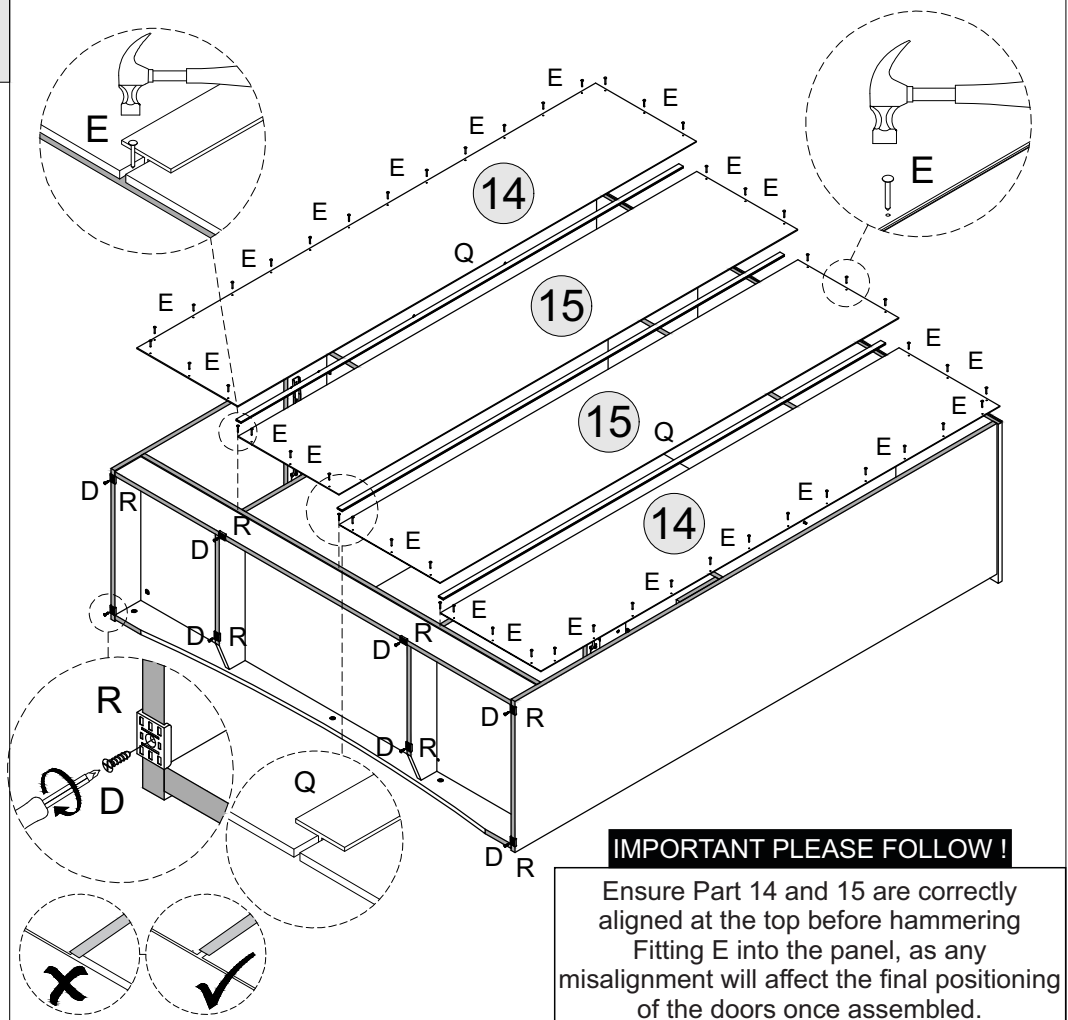
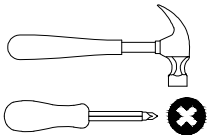

STEP 18

PARTS REQUIRED

16 - DRAWER BACK	x2
17 - DRAWER SIDE - LEFT	x2
18 - DRAWER SIDE- RIGHT	x2
19 - DRAWER FRONT	x2

HARDWARE REQUIRED

A		16
B		04
O		04

TOOLS REQUIRED

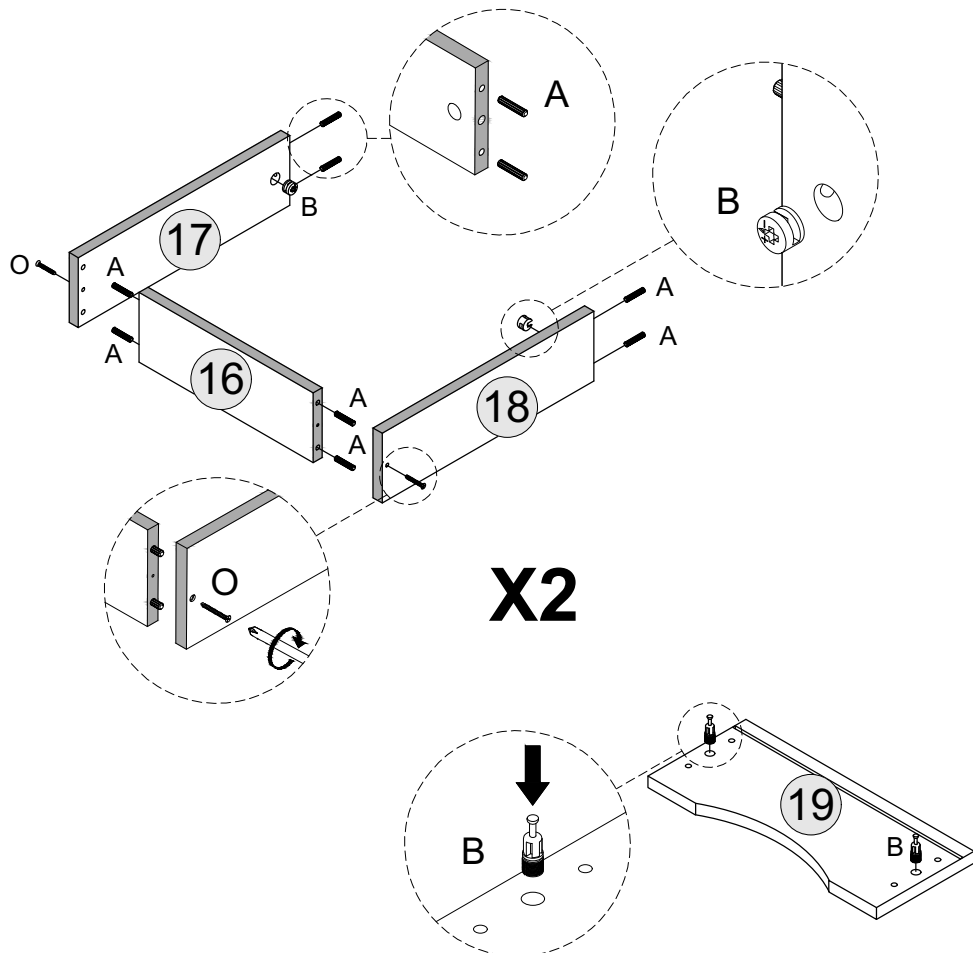
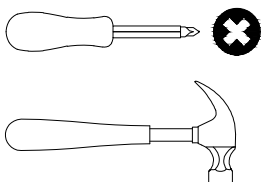

STEP 19

PARTS REQUIRED

19 - DRAWER FRONT	x2
20 - DRAWER BASE	x2

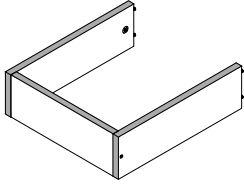

HARDWARE REQUIRED

E		08
---	--	----

TOOLS REQUIRED

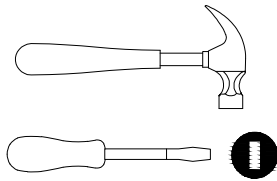

X2

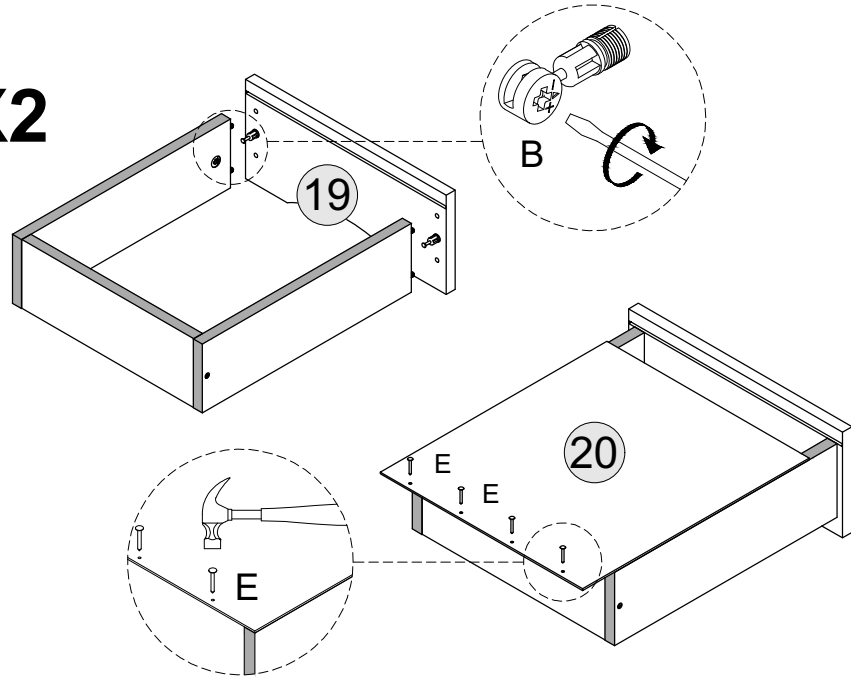

IMPORTANT PLEASE FOLLOW !

Ensure Part 20 is correctly aligned and square with the drawer frame before hammering Fitting E into the side, as any misalignment will affect the final positioning of the drawers once assembled.

STEP 20

PART REQUIRED

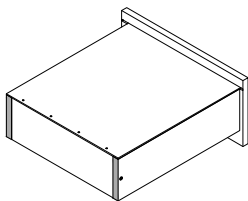

HARDWARE REQUIRED

D		12
N		04

TOOLS REQUIRED

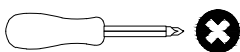

X2

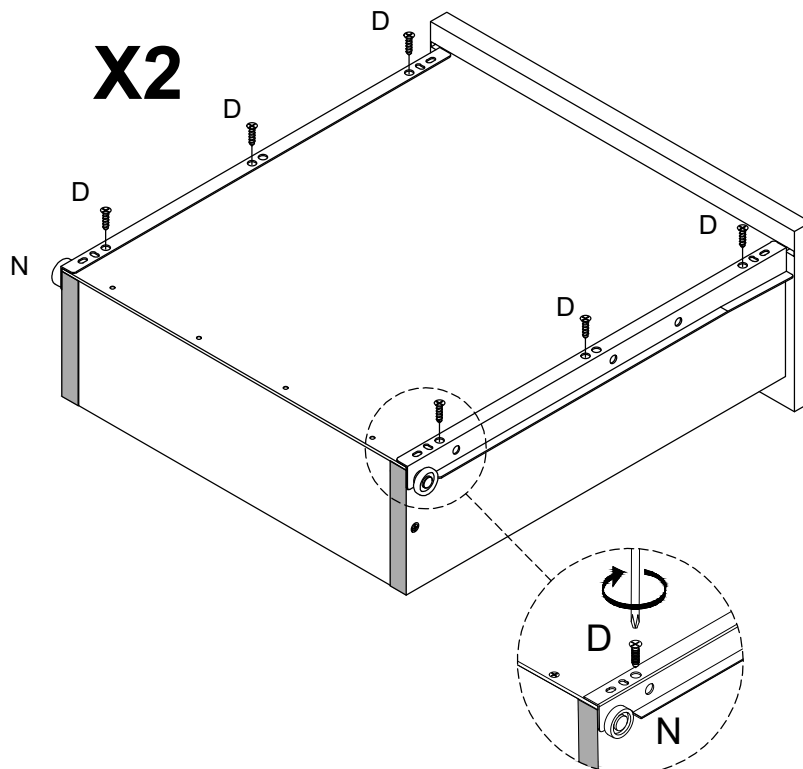



STEP 21

PARTS REQUIRED

21 - DOORS	x2
22 - DOORS MIRROR	x2

HARDWARE REQUIRED

D		24
K		12

TOOLS REQUIRED

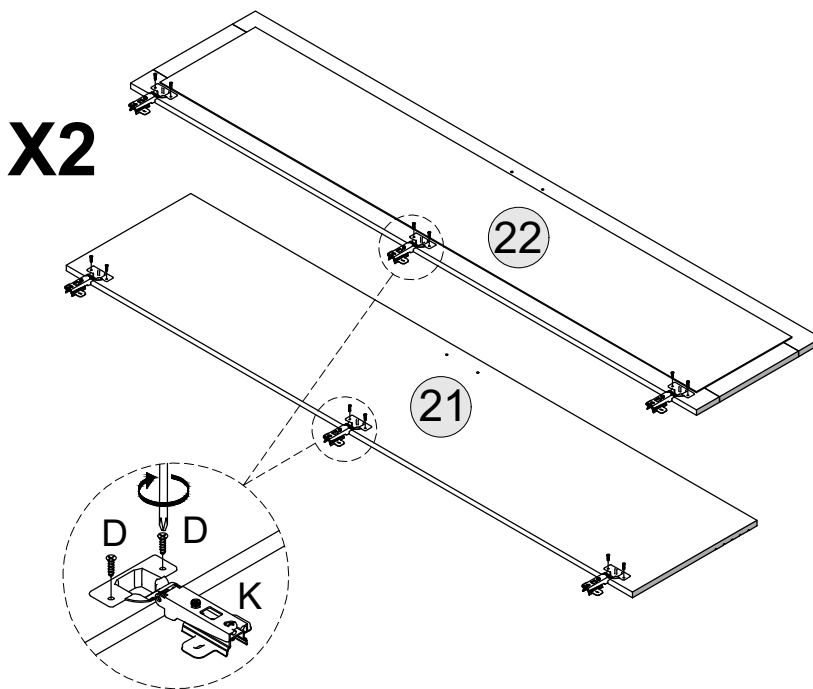
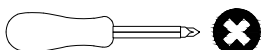



STEP 22

PART REQUIRED

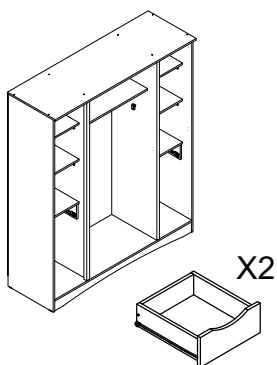
21 - DOOR	x1
23 - SHELF PANEL	x4



HARDWARE REQUIRED

F		02
G		01
H		06

TOOLS REQUIRED

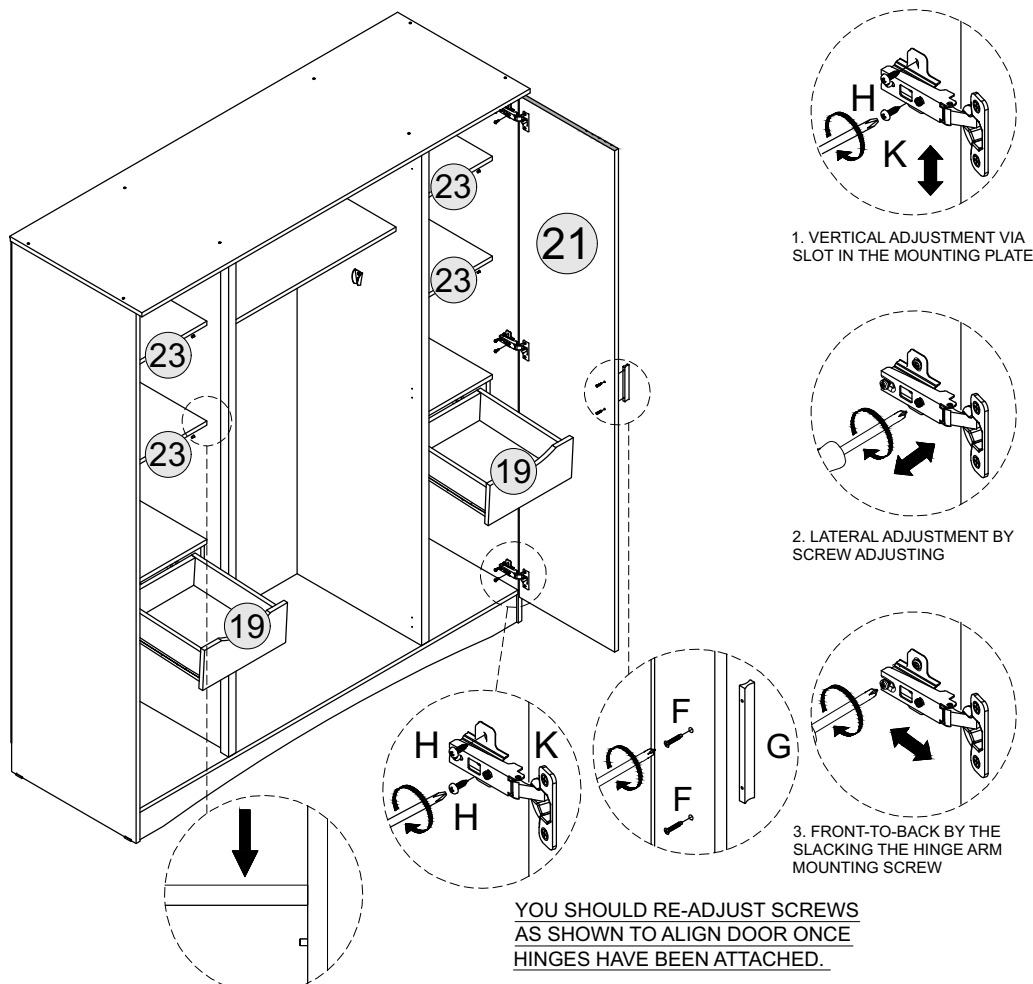
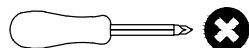



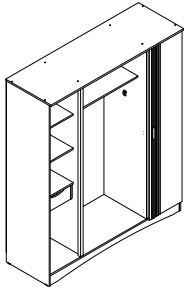

STEP 23

PART REQUIRED

22 - MIRRORED DOOR x1



HARDWARE REQUIRED

- F  02
- G  01
- H  06
- T  01

TOOLS REQUIRED

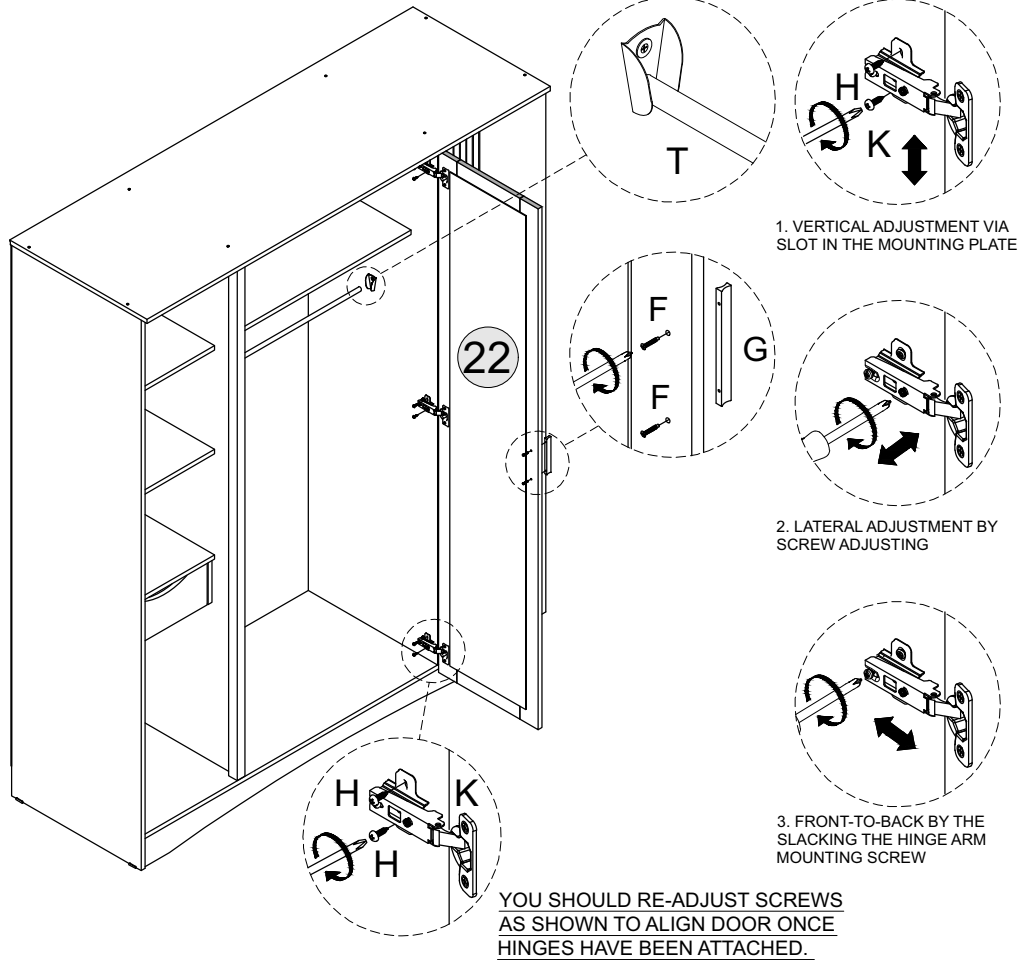
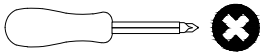

STEP 24



PART REQUIRED

21 - DOOR x1

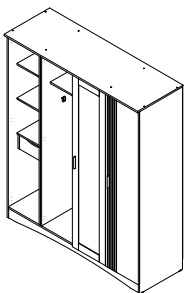
22 - MIRRORED DOOR x1



HARDWARE REQUIRED

- F  04
- G  02
- H  12

TOOLS REQUIRED

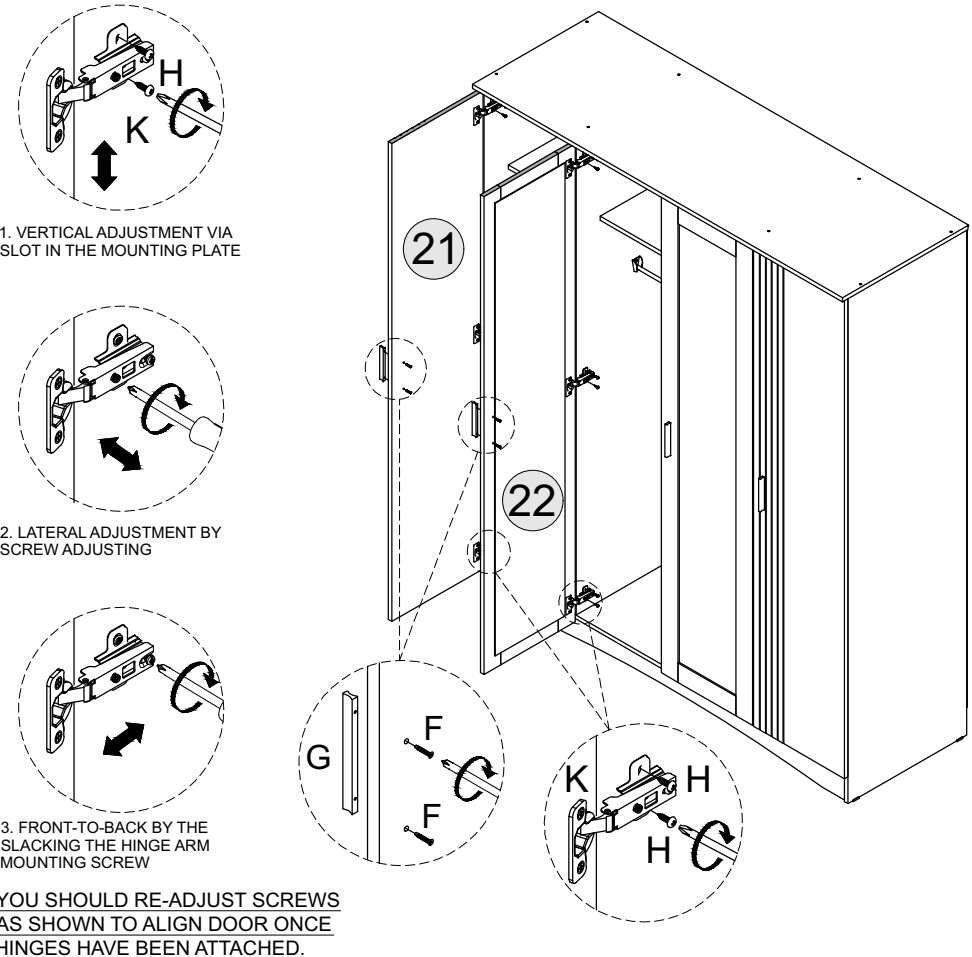
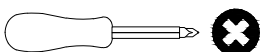

STEP 25

PARTS REQUIRED

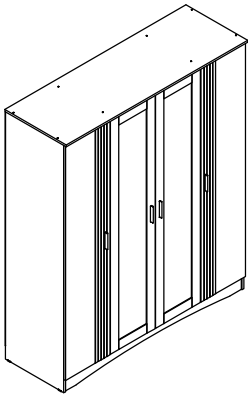

HARDWARE REQUIRED

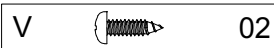

TOOLS REQUIRED

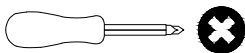

WARNING

Serious or fatal injuries can occur from furniture tipping over. To prevent the furniture from tipping over we recommend that it is permanently fixed to the wall.

Wall fixings are not supplied with this product as different wall materials require different types of fixing devices. Please make sure you use fixings suitable for the walls in your home.

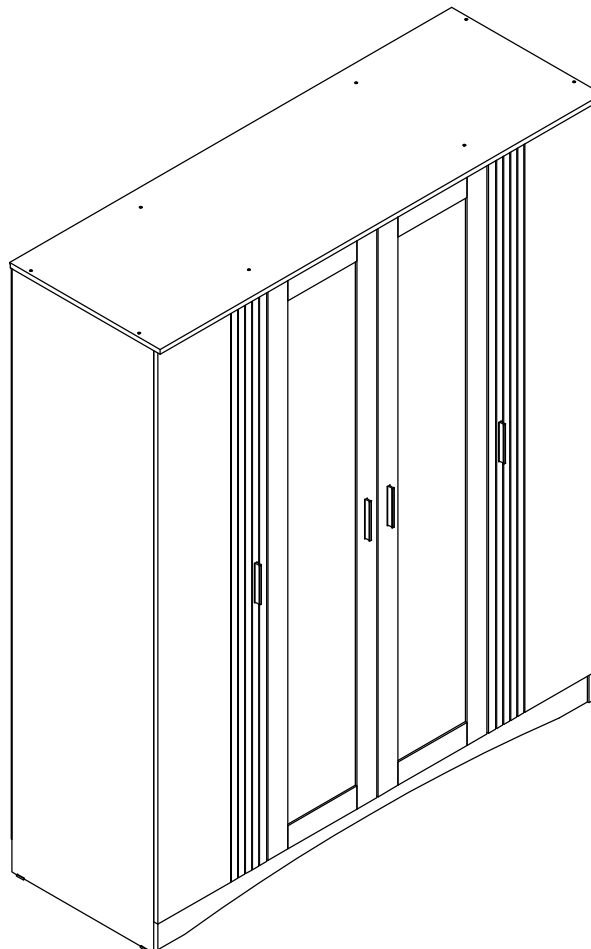
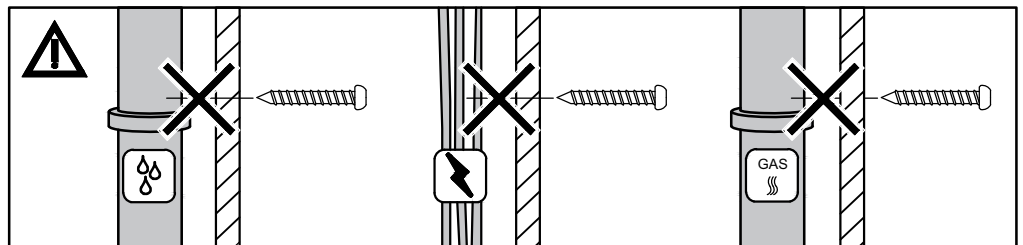
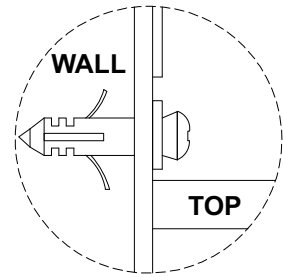
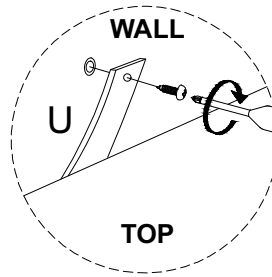
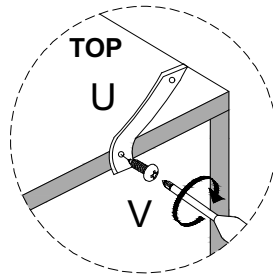

LARGE SHELF
MAX WEIGHT



SMALL SHELF
MAX WEIGHT



HANGING RAIL
MAX WEIGHT



MAX DRAWER
WEIGHT

<p style="text-align: center;">INFORMATIONS IMPORTANTES (FRENCH)</p> <p style="text-align: center;">IMPORTANTE POUR USAGE DOMESTIQUE UNIQUEMENT VEUILLEZ LIRE AVANT DE CONTINUER</p> <p>Le produit que vous avez acheté vous offrira de nombreuses années de service si vous suivez les directives pour son assemblage sûr et son entretien et nettoyage périodiques. Montez sur une surface douce et propre. N'utilisez aucun autre outil que ceux indiqués. Les clés ou clés Allen nécessaires sont fournies avec le kit de fixation. En fonction de la fréquence d'utilisation de ce produit, il peut être nécessaire de resserrer les fixations de temps en temps. Cela est tout à fait normal pour tout meuble en kit. Ce produit comprend du verre trempé d'une épaisseur nominale de 8 mm. Si le verre est ébrêché ou cassé, remplacez-le par le type décrit ou consultez les détaillants en indiquant les détails du modèle. AVERTISSEMENT La charge maximale sur le dessus ne doit pas dépasser la limite de poids indiquée sur la première page. Ne vous asseyez pas ou ne vous tenez pas debout sur les surfaces en verre. N'utilisez pas le verre comme surface de coupe. Ne frappez pas le verre avec des objets durs ou pointus. Ne placez pas d'objets très chauds ou très froids sur la surface en verre, à moins que des sets de table suffisamment épais ne soient utilisés pour empêcher ces objets d'entrer en contact avec le verre. Pour nettoyer les panneaux en verre, utilisez un chiffon humide ou un cuir avec du liquide vaisselle ou du savon doux si nécessaire. N'utilisez pas de lessive en poudre ou toute autre substance contenant des abrasifs car ceux-ci rayent considérablement le verre. L'utilisation d'outils électriques pour assembler ce produit invalidera toute réclamation et peut endommager ce produit, le rendant dangereux. Conservez ces instructions dans un endroit sûr pour référence ultérieure.</p>	<p style="text-align: center;">INFORMACIÓN IMPORTANTE (SPANISH)</p> <p style="text-align: center;">IMPORTANTE SOLO PARA USO DOMÉSTICO LEER ANTES DE CONTINUAR</p> <p>El producto que ha adquirido le brindará muchos años de servicio si sigue las pautas para su montaje seguro y su mantenimiento y limpieza periódicos. Ensamble sobre una superficie suave y limpia. No utilice herramientas distintas a las que se muestran. Las llaves inglesas o llaves Allen necesarias se incluyen con el kit de accesorios. Dependiendo de la cantidad de uso que reciba este producto, puede ser necesario apretar las fijaciones de vez en cuando. Esto es completamente normal en cualquier mueble de paquete plano. Este producto incluye vidrio templado con un espesor nominal de 8 mm. Si el vidrio está astillado o roto, reemplácelo con el tipo descrito o, alternativamente, consulte con los minoristas indicando los detalles del modelo. ADVERTENCIA La carga máxima en la parte superior no excede el límite de peso que se muestra en la página principal. No se siente ni se pare sobre superficies de vidrio. No use el vidrio como superficie para cortar. No golpee el vidrio con elementos duros o puntiagudos. No coloque elementos muy calientes o muy fríos sobre la superficie de vidrio a menos que se utilicen manteles individuales lo suficientemente gruesos para evitar que dichos elementos entren en contacto con el vidrio. Para limpiar los paneles de vidrio, utilice un paño húmedo o un paño de cuero con detergente líquido o jabón suave, si es necesario. No utilice detergente en polvo ni ninguna otra sustancia que contenga abrasivos, ya que rayan considerablemente el vidrio. El uso de herramientas eléctricas para ensamblar este producto invalidará cualquier reclamo y puede dañar este producto, haciéndolo inseguro. Guarde estas instrucciones en un lugar seguro para futuras consultas.</p>
<p style="text-align: center;">WICHTIGE INFORMATIONEN (GERMAN)</p> <p style="text-align: center;">WICHTIGUR FÜR DEN HAUSHALTSGEBRAUCH BITTE LESEN SIE, BEVOR SIE FORTFAHREN</p> <p>Das von Ihnen erworbene Produkt wird Ihnen viele Jahre lang gute Dienste leisten, wenn Sie die Richtlinien für eine sichere Montage und regelmäßige Wartung und Reinigung befolgen. Auf einer weichen, sauberen Oberfläche montieren. Verwenden Sie keine anderen Werkzeuge als die abgebildeten. Alle benötigten Schraubenschlüssel oder Inbusschlüssel sind im Montagesatz enthalten. Je nach Nutzungsintensität dieses Produkts kann es erforderlich sein, die Befestigungen von Zeit zu Zeit festzuziehen. Dies ist bei Möbeln aus dem Bausatz völlig normal. Dieses Produkt enthält gehärtetes Glas mit einer Nennstärke von 8 mm. Wenn das Glas angeschlagen oder zerbrochen ist, ersetzen Sie es bitte durch das beschriebene Glas oder wenden Sie sich alternativ an den Händler und geben Sie die Modelldetails an. WARNUNG Die maximale Belastung oben darf die auf der Titelseite angegebene Gewichtsgrenze nicht überschreiten. Setzen oder stellen Sie sich nicht auf Glasoberflächen. Verwenden Sie Glas nicht als Schneideunterlage. Schlagen Sie nicht mit harten oder sehr kalten Gegenständen auf Glas. Stellen Sie keine sehr heißen oder sehr kalten Gegenstände auf die Glasoberfläche, es sei denn, Sie verwenden ausreichend dicke Tischmatten, um zu verhindern, dass diese Gegenstände mit dem Glas in Berührung kommen. Verwenden Sie zum Reinigen von Glasscheiben ein feuchtes Tuch oder Leder mit Spülmittel oder Schmierseife, falls erforderlich. Verwenden Sie kein Waschpulver oder andere scheuernde Substanzen, da diese das Glas stark zerkratzen. Die Verwendung von Elektrowerkzeugen zur Montage dieses Produkts macht jegliche Ansprüche ungültig und kann das Produkt beschädigen, wodurch es unsicher wird. Bewahren Sie diese Anleitung zum späteren Nachschlagen an einem sicheren Ort auf.</p>	<p style="text-align: center;">INFORMAZIONI IMPORTANTI (ITALIAN)</p> <p style="text-align: center;">IMPORTANTE, SOLO PER USO DOMESTICO SI PREGA DI LEGGERE PRIMA DI CONTINUARE OLTRE</p> <p>Il prodotto che hai acquistato ti garantirà molti anni di servizio se seguirai le linee guida per il suo montaggio sicuro e la manutenzione e pulizia periodiche. Montare su una superficie morbida e pulita. Non utilizzare utensili diversi da quelli mostrati. Tutte le chiavi inglesi o le chiavi a brugola necessarie sono incluse nel kit di accessori. A seconda della quantità di utilizzo di questo prodotto, potrebbe essere necessario stringere i fissaggi di tanto in tanto. Ciò è del tutto normale per qualsiasi mobile in kit. Questo prodotto include vetro temperato con uno spessore nominale di 8 mm. Se il vetro è scheggiato o rotto, sostituirlo con il tipo descritto o in alternativa consultare i rivenditori indicando i dettagli del modello. AVVERTENZA Il carico massimo sulla parte superiore non deve superare il limite di peso indicato sulla prima pagina. Non sedersi o stare in piedi sulle superfici in vetro. Non utilizzare il vetro come superficie di taglio. Non colpire il vetro con oggetti duri o appuntiti. Non posizionare oggetti molto caldi o molto freddi sulla superficie in vetro a meno che non vengano utilizzati tovagliette adeguatamente spesse per evitare che tali oggetti entrino in contatto con il vetro. Per la pulizia dei pannelli in vetro, utilizzare un panno umido o pelle con detersivo per piatti o sapone delicato, se necessario. Non utilizzare detersivo in polvere o altre sostanze contenenti abrasivi, poiché graffiano notevolmente il vetro. L'uso di utensili elettrici per assemblare questo prodotto invaliderà qualsiasi reclamo e potrebbe danneggiare il prodotto rendendolo non sicuro. Conservare queste istruzioni in un luogo sicuro per riferimento futuro.</p>