

ASSEMBLY INSTRUCTIONS

Read this instruction carefully. Refer hardware and furniture parts list for guidance. Be sure all parts are complete, before assembling. Place all wooden furniture part on a clean and flat soft surface to prevent scratcheds. Refer steps provided as assembling guide.

CAUTIONS :

1. Do not **FULLY-TIGHTEN** the nuts or nut bolts until all are in place.
2. To prevent thread damage. Ensure that nuts or nut bolts are not over-tighten.
3. Hardware are to be kept out of reach from children.

PART LIST			HARDWARE LIST		
ITEM	DESCRIPTION	QTY	ITEM	DESCRIPTION	QTY
A	HEADBOARD	1 PC	1	JCBC SCREW M6 x 35MM	2 PCS
B	LEG	2 PCS	2	JCBC SCREW M6 x 40MM	24 PCS
C	MATTRESS PANEL (L & R)	2 PCS	3	SPRING WASHER 1/4"	26 PCS
D	WOODEN SUPPORT	1 PC	4	M4 ALLEN KEY (BALL SHAPE) LONG	1 PC
			5	WOOD DOWEL DIA 8 x 35MM	2 PCS
			6	FLAT WASHER 1/4"	26 PCS
			7	BOLT BASE GLIDE M6 x 23 (C83)	2 PCS

STEP 1

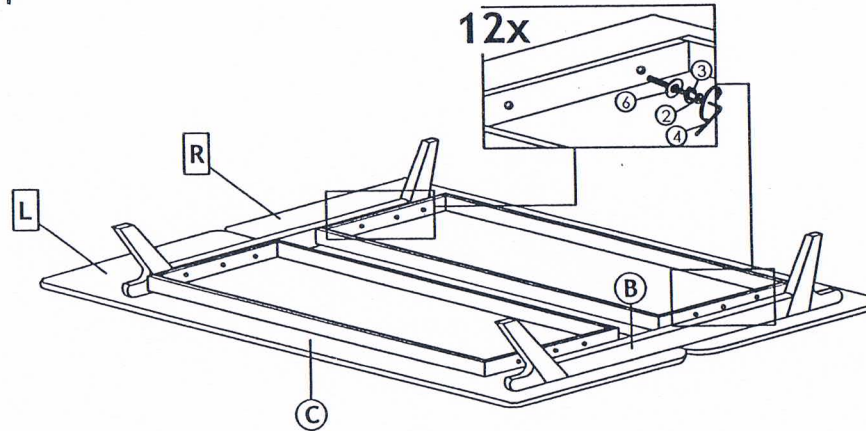

STEP 2

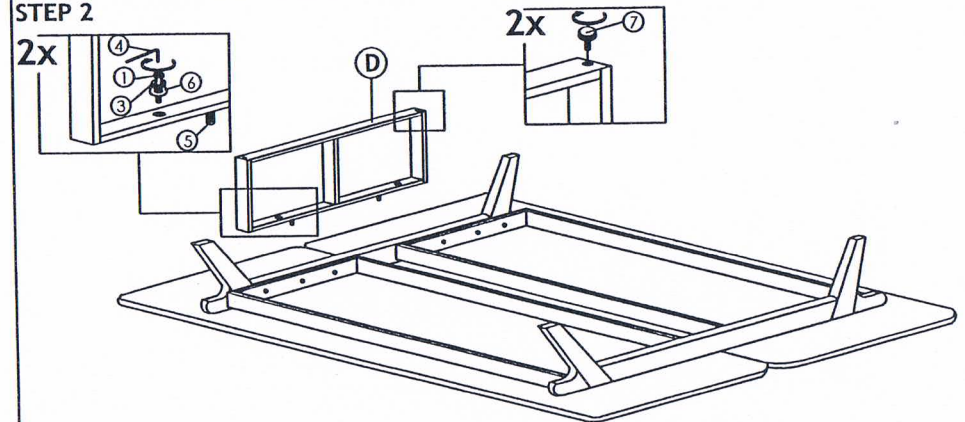

STEP 3

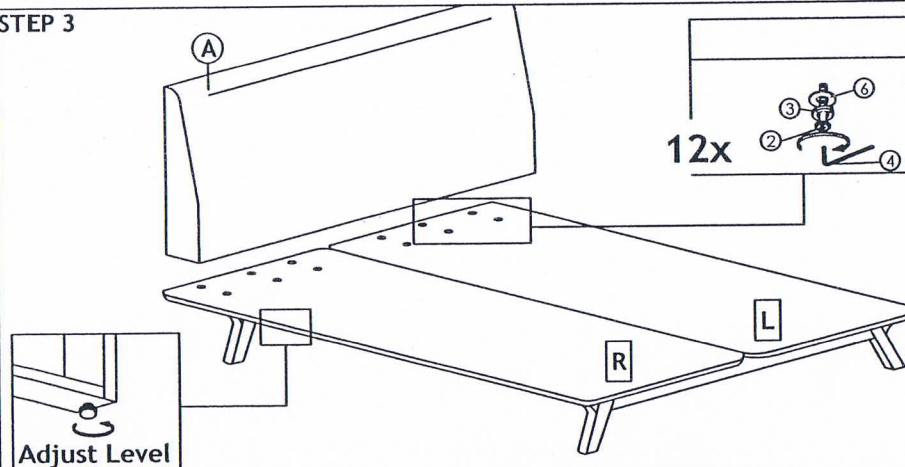

STEP 4

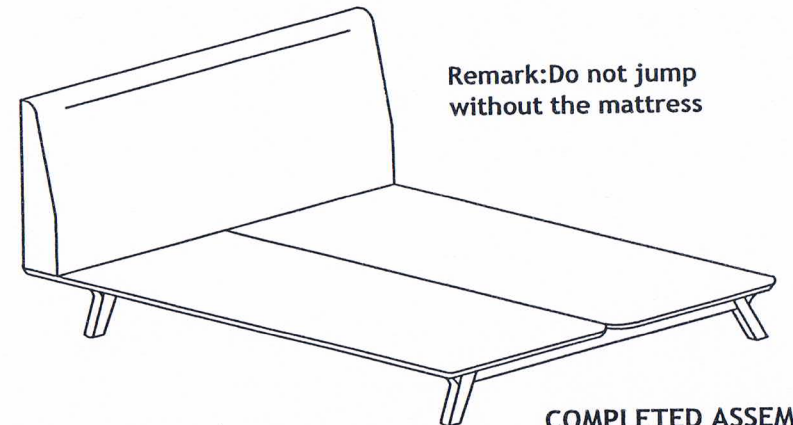

COMPLETED ASSEMBLY