

FULL/ QUEEN BED ASSEMBLY INSTRUCTIONS

PARTS PACKING CONFIGURATIONS

BOX #1:

- A. HEADBOARD 1 PC
- F. STRETCHER 1 PC
- G. RIGHT LEG 1 PC
- H. LEFT LEG 1 PC

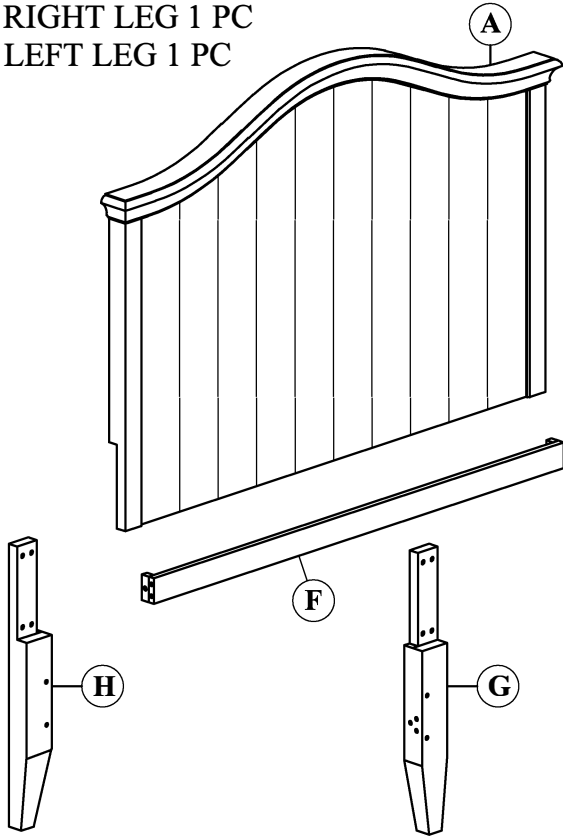

BOX #2:

- B. FOOTBOARD 1 PC
- D. SLAT ROLL (1 SET)
- E. SUPPORT LEG 5 PCS

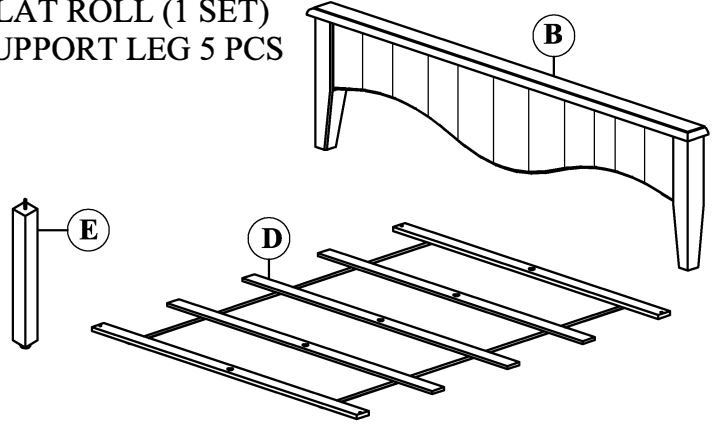

BOX #3:

- C. SIDE RAIL 2 PCS

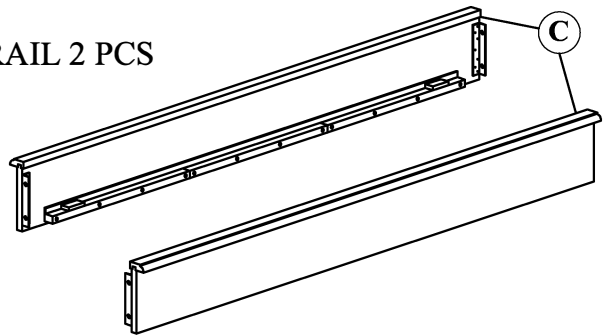

ASSEMBLY COMPLETE

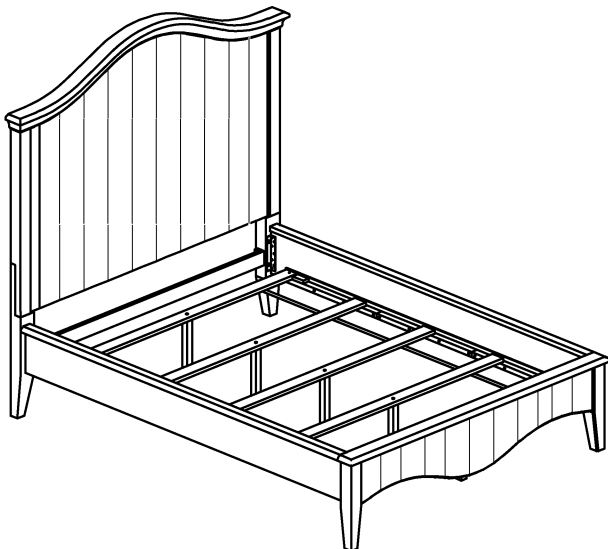

HARDWARE PACKED IN BOX #1

No	Description	Image	Quantity
1	ALLEN BOLT (8x38mm)		2 PCS
2	ALLEN BOLT (8x50mm)		8 PCS
3	SPRING WASHER (M8)		10 PCS
4	FLAT WASHER (M8)		10 PCS
5	ALLEN KEY (M4)		1 PC

HARDWARE PACKED IN BOX #2

No	Description	Image	Quantity
6	WOOD SCREW (4x30mm)		4 PCS
7	ALLEN BOLT (8x20mm)		8 PCS
8	SPRING WASHER (M8)		8 PCS
9	FLAT WASHER (M8)		8 PCS
10	ALLEN KEY (M4)		1 PC



Not provided

FULL/ QUEEN BED ASSEMBLY INSTRUCTIONS

STEP 1:

NOTE! USE HARDWARE PACKED IN BOX #1 FOR STEP 1.

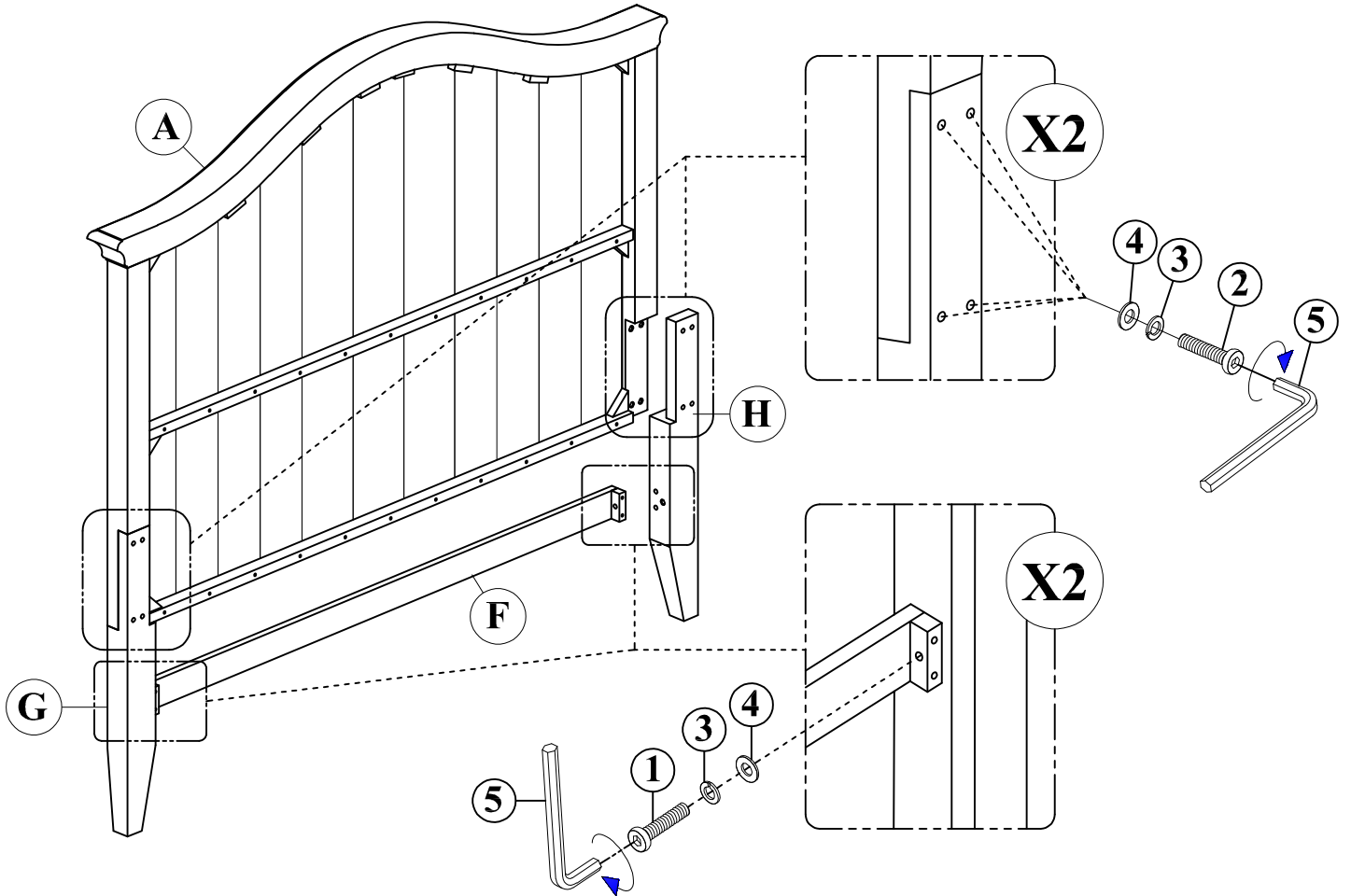

STEP 2:

NOTE! USE HARDWARE PACKED IN BOX #2 FOR REMAINING STEPS.

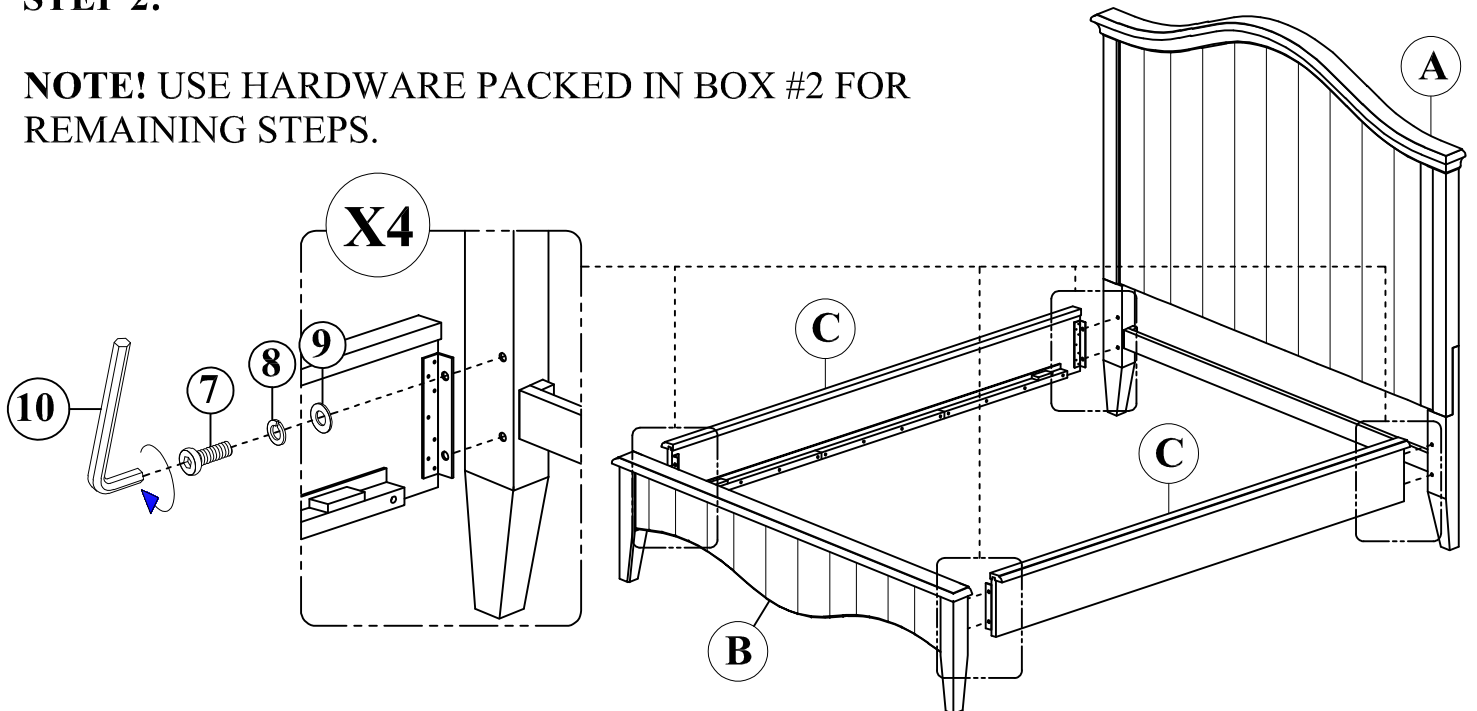

FULL/ QUEEN BED ASSEMBLY INSTRUCTIONS

STEP 3:

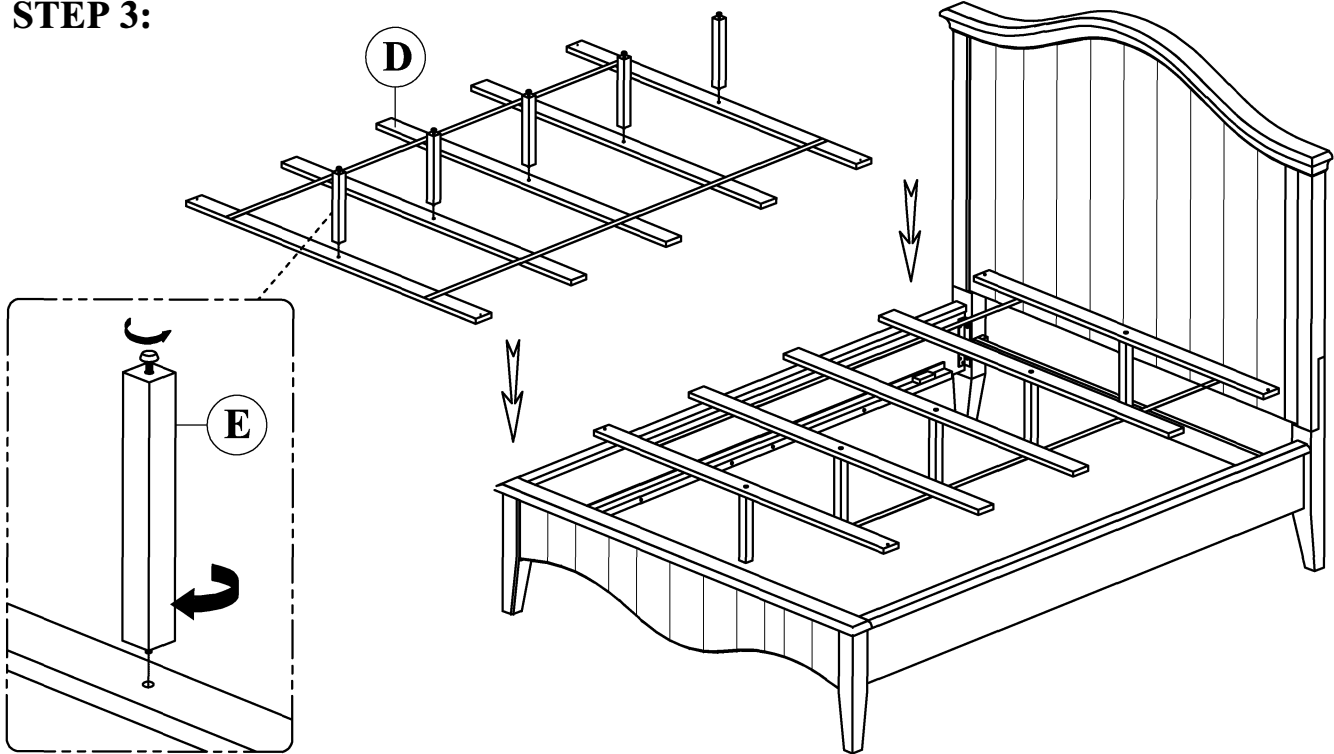

STEP 4:

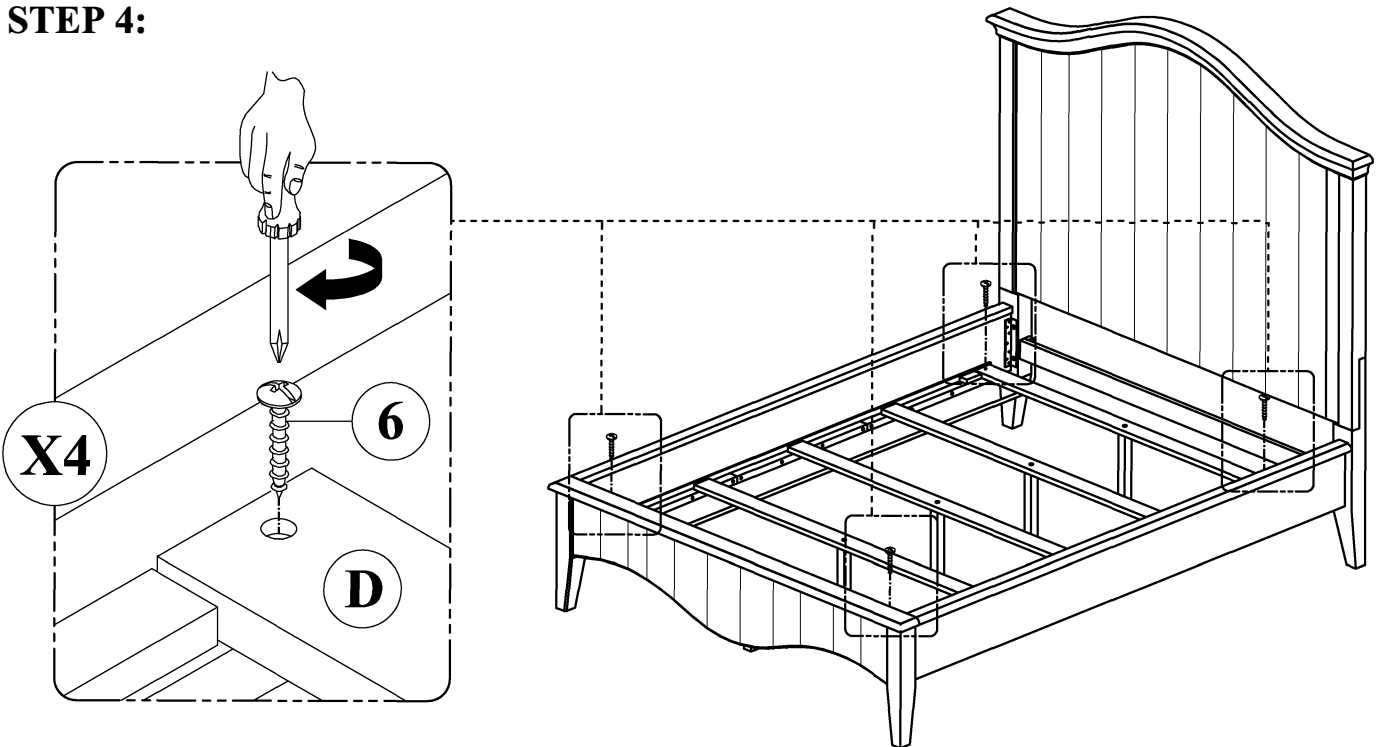

INSTRUCTIONS FOR ADJUSTING LEVELER:

POSITION THE BED IN YOUR SPACE AND LOCATE THE LEVELER UNDER EACH SUPPORT LEG.

TURN THE LEVELER COUNTER-CLOCKWISE TO EXTEND THE LEVELER AND CLOCKWISE TO RETRACT IT.

ADJUST EACH LEVELER UNTIL EACH SUPPORT LEG IS APPLYING EQUAL, UPWARD PRESSURE ON THE SUPPORT SLAT.

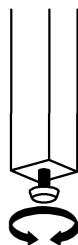

MAINTENANCE INSTRUCTIONS:

REMOVE YOUR MATTRESS, AND BOX SPRING IF APPLICABLE, BEFORE MOVING YOUR BED.

LIFT YOUR BED WHEN MOVING IT; DRAGGING CAN DAMAGE THE SUPPORTS.

RE-ADJUST THE LEVELERS AFTER MOVING YOUR BED.