

Air Scrubber Owner's Manual

Model: X550

Power Supply: (115 V~, 60Hz)
Read and save these instructions before use

Customer Support:
Tel: +1 (888) 669-8399
Email: support@xtreway.com
Warranty Registration:
<https://www.xtreway.com/warranty>



Intertek
5030333

The Xtreway X550 air scrubber is a powerful air filtration device designed to enhance indoor air quality by removing contaminants, allergens, and odors. Suitable for homes, offices, and industrial environments, the X550 operates by drawing air through advanced filters, including HEPA and Prefilter, to capture particles as small as 0.3 microns. The X550 effectively mitigates dust, smoke, pet dander, and chemical fumes, ensuring a healthier indoor environment. Compact, efficient, and user-friendly, the X550 is designed to provide clean air wherever it is needed.

Important Safety Instructions

Read and understand before operating:

WARNINGS

To reduce the risk of electric shock: **Avoid Water Exposure:**

Do not expose the unit to water or rain.

- **Handling:** Never move or carry the air scrubber while it is operating. The powerful airflow may cause unpredictable movement.
- **Child Safety:** Keep the unit away from children and NEVER allow them to play with or near the device.
- **Placement:** Operate the unit only on flat, stable surfaces to prevent tipping or slipping, which could lead to injury, fire, or electric shock.
- **Liquid Prevention:** Avoid letting liquids enter the unit. Operate only with factory-installed safety grills in place.
- **Filter Changes:** Unplug the unit before performing any service or replacing filters.
- **Stacking: DO NOT** stack more than two units to avoid tipping hazards– falling equipment can cause bodily harm.

Parts Identification:

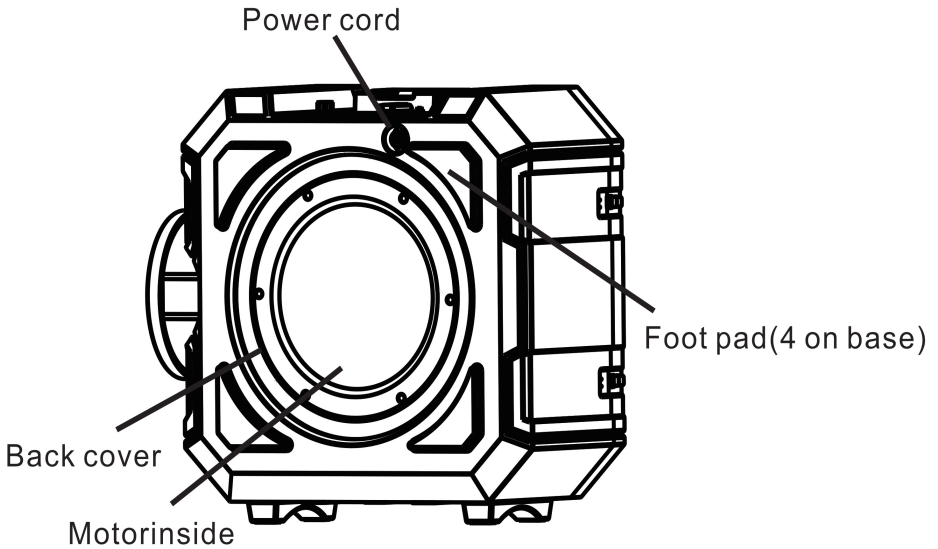
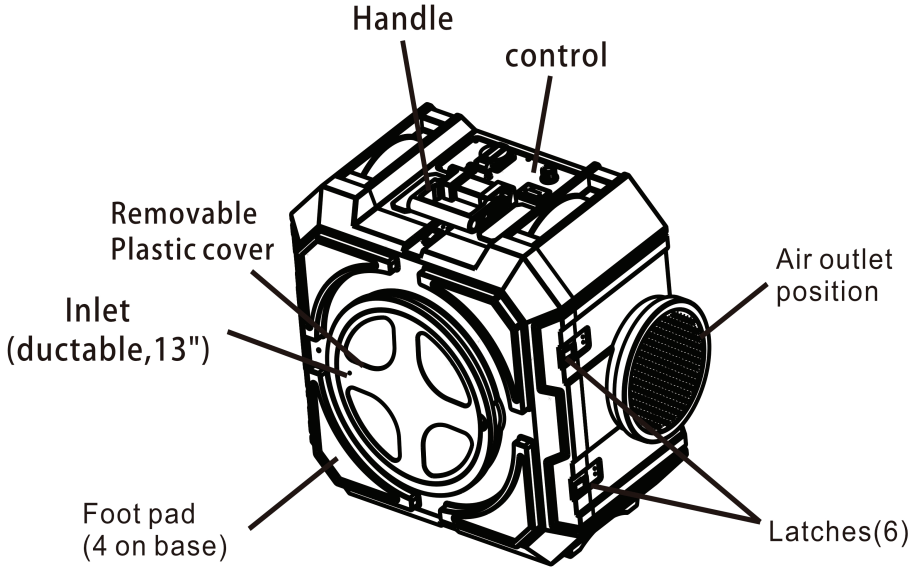

Machine

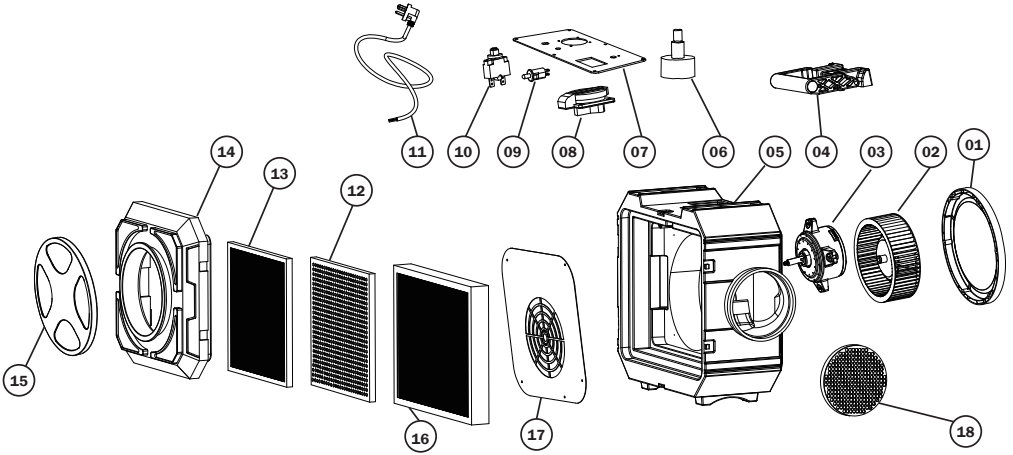

01	Fan Cover	10	Power Reset
02	Wind turbines	11	Power Cord
03	DC Motor	12	Carbon Filter
04	Outlets	13	Air Pre-cleaner
05	Housing	14	Suction Canal
06	Speed Control	15	Airinlet cover
07	Control Panel Assembly	16	Hepa Filter
08	Hour Meter	17	Air Intake Panel
09	Switch	18	Air Outlet Grille

Applications:

Air scrubbers are highly versatile devices that enhance air quality across residential, commercial, and industrial environments. In homes, they eliminate allergens, pet dander, and odors, fostering healthier living spaces. In commercial settings such as offices, gyms, and schools, they maintain clean air by filtering dust, pollen, and bacteria. For industrial use, air scrubbers capture harmful pollutants, fumes, and volatile organic compounds (VOCs) in factories and workshops. During construction and renovation projects, they effectively control dust and debris. They are also crucial in disaster restoration, removing smoke, mold spores, and waterborne contaminants. When integrated with HVAC systems, air scrubbers improve airflow and filtration, ensuring cleaner and safer environments.

- **Residential:** Removes allergens, pet dander, and odors; reduces airborne bacteria, viruses, and mold spores.
- **Commercial:** Maintains air quality in offices, schools, healthcare facilities, hotels, gyms, and restaurants.
- **Industrial:** Filters harmful pollutants, fumes, and volatile organic compounds (VOCs) in factories or workshops.
- **Construction/Renovation:** Captures dust and debris during drywall sanding, painting, and demolition.
- **Disaster Restoration:** Removes smoke, mold spores, and waterborne contaminants in fire- or flood-affected areas.
- **HVAC Integration:** Enhances airflow and filtration when integrated with HVAC systems.

Specifications:

Model	X550
Airflow	Variable to 550 CFM
Construction	38.5 lbs. 17.2 Kg
Dimensions (H × D × W)	24.4 × 15.8 × 23.2 in. 62 × 40 × 59 cm
Amps/Power	1.2 amps (Max) , 115v, 60 Hz, 110w(Max)
Power cord	23 ft. 7.0 m
Filter	MERV-10 Filter, Prefilter and HEPA Filter
Motor	DC Inverter Motor
Construction	Injection-molded plastic housing
<i>Specifications are subject to change without notice. Some values may be approximate.</i>	

Special Features

The air scrubber is equipped with a **DC Inverter Motor**, delivering superior performance with several key advantages:

DC Inverter Motor:

- Quiet operation for noise-sensitive environments.
- Energy-efficient with low power consumption.
- Smooth, consistent airflow control with variable speed adjustments.

Control Panel

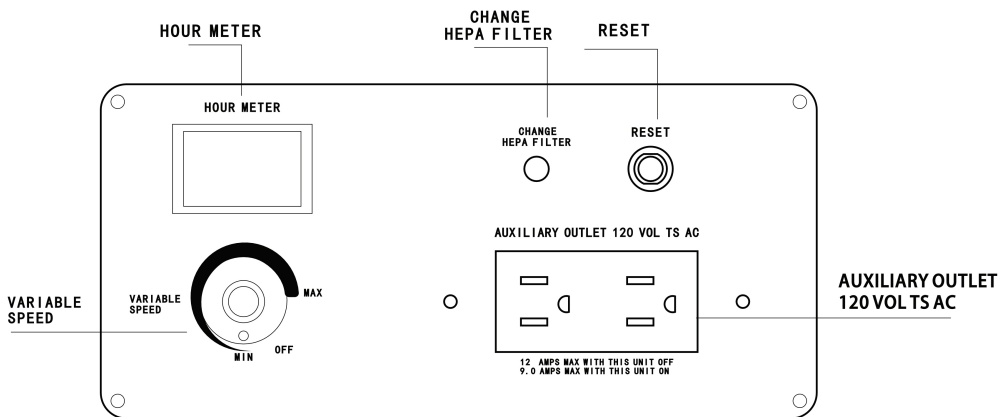

Variable Speed Control

Adjustable airflow for customized purification needs

 **Variable speed control** is used to adjust the power of the machine. Turn the speed the knob in a clockwise direction to increase the speed from minimum speed to maximum. The minimum speed setting is located immediately close to OFF.

*** We use a DC Inverter Motor to reach Variable Speed Control. ****

Auxiliary Outlet:

Daisy-chain up to two units for extended air filtration

- The X550 air scrubber allows for daisy-chaining up to two units to meet customized air filtration needs.

Maximum load: 12 amps (off) and 9 amps (on).

- Other equipment can be plugged into the same outlet as the air scrubber as long as it doesn't go above the max amperage.

Reset (Circuit Breaker Switch)

⦿ Protects the unit if more than 12 amps of electricity are passing the circuit. If this occurs, the switch will cut off the power to the unit. The air scrubber is equipped with a Circuit Breaker Switch designed to safeguard the unit from electrical overloads.

Once the issue is resolved, the circuit breaker can be reset by simply toggling the switch, ensuring quick and convenient recovery.

HOURLY METER (Timer):

The air scrubber features a Timer Function to monitor and manage its operation efficiently. This intuitive function ensures precise timing for optimized performance and convenience, allowing users to maintain the unit efficiently.

- **Run time tracking:** The timer automatically starts counting when the device is powered on and actively running.
- **Pause when stopped:** If the device is turned off or paused, the timer stops tracking, resuming once the unit is restarted.
- **Usage monitoring:** Ideal for keeping track of operation time, helping with scheduled maintenance or usage planning.
- **HOURLY METER:** The digital tube displays the running time of the filter. Press "HOURLY METER" key to switch between Display current running time and total running time. Press and holding the key "HOURLY METER" to clean the timer to 0. Then the total running time be "0".

Maintenance

About the Filter

3 Level Filter	Prefilter	Specialty Prefilter	Primary Filter(HEPA)
Air Filtration Applications	Removes larger particulates - protects primary filter	Removes VOCs AND odors	Removes fine particulate down to 0.3microns
Filter	MERV-10 Filter	Prefilter	HEPA Filter
Filter Size	15.8 x 15.8 x7.9 in	15.8 x 15.8 x 15.8 in	18.9 x 15.8 x 21.7 in

Filter Replacement

- **Access Filters:** Unlock the filter panel by loosening the locks or screws. Loosen the 6 locks that hold the filter board in unit. Then remove the dust cover or access panel. This may require unscrewing or unclipping the panel.
- **Remove Used Filters:** Carefully take out the used filters, starting with the outer MERV-10 Filter, Prefilter, and HEPA Filter.
- **Install New Filters:** Insert new filters in the correct order: HEPA filter, followed by the prefilter, and MERV-10 Filter. Ensure they fit snugly and are aligned properly within the filter housing.

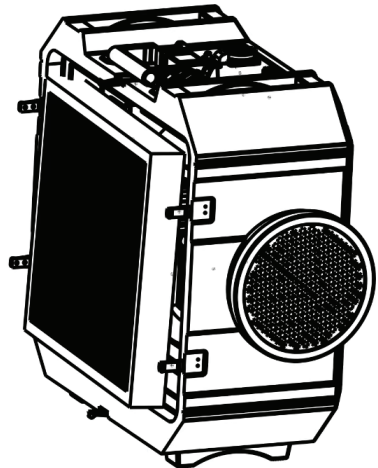
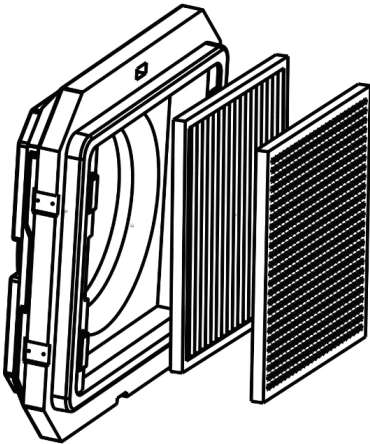

Wiring Diagram

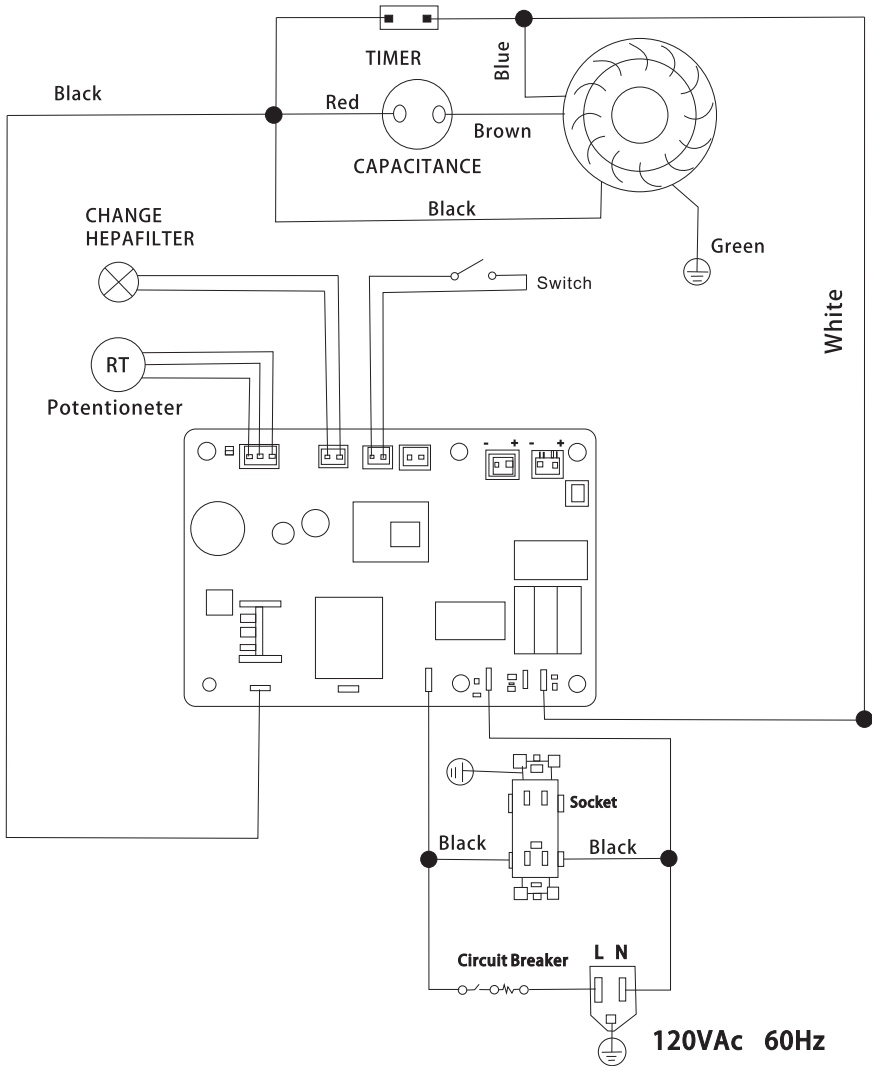

Indicator Lights

HEPA Filter Change: Illuminates after 2,000 hours of use. Replace the filter and reset the indicator light. When the unit has been running for a total of 2,000 hours, the “CHANGE HEPA FILTER” light will illuminate, indicating it is time to replace the HEPA filter. After replacing the filter, the light will automatically turn off.

Warranty Registration

After purchasing and receiving your package, follow these simple steps to register your warranty:

Visit: <https://xtreway.com/warranty>
Fill out the registration form with the following details:

- Equipment Model
- Order Number
- Email ● Phone ● Number ● Full Name

Registering your product ensures warranty coverage and provides faster service for any future support needs.

Warranty Policy

This Air Scrubber is warranted to the original purchaser to be free from defects in materials and workmanship under normal use and service for a period of 2 years from the date of purchase. During the warranty period, we will repair or replace, at our discretion, any defective part or product free of charge. This warranty does not cover:

- Normal wear and tear, including filter replacements.
- Damage caused by misuse, abuse, neglect, or improper maintenance.
- Unauthorized modifications or repairs.
- Damage resulting from acts of nature or external factors, such as power surges or water damage.

To obtain warranty service, contact our customer support team with proof of purchase. The purchaser is responsible for shipping costs to the service center. This warranty is non-transferable and applies only to products used within their intended environment. This warranty is in lieu of all other warranties, express or implied, including warranties of merchantability or fitness for a particular purpose. Some states do not allow limitations on implied warranties, so these exclusions may not apply.

For more information, please contact our customer service team at support@xtreway.com

Safety Notes

Electrical Safety:

- Always plug the air scrubber into a properly grounded 115V outlet.
- Avoid using extension cords or adapters to prevent electrical hazards.
- Ensure the outlet is protected by a Ground Fault Circuit Interrupter.

Placement:

- Place the unit on a stable, level surface to prevent tipping.
- Keep the air scrubber away from water, flammable materials, or heat sources.

Operation:

- Do not block the air intake or outlet.
- Avoid running the unit with damaged cords or filters.
- Turn off and unplug the unit before cleaning or maintenance.

Health Precautions:

- Use the air scrubber in well-ventilated areas.
- Avoid direct exposure to airflow for extended periods.

Children and Pets:

- Keep the unit out of reach of children and pets to prevent accidents.

Maintenance:

- Replace filters as indicated by the filter change light.
- Follow all maintenance instructions to ensure optimal performance and safety.

Emergency:

- If the unit emits unusual odors, smoke, or sounds, unplug it immediately and contact customer service.

Xtreway Technology Inc.

 1312 17th Street Suite 1220,
Denver, CO 80202

 www.xtreway.com

Customer Support:

Tel: +1 (888) 669-8399

Email: support@xtreway.com

Warranty Registration:

<https://xtreway.com/warranty>

Scan below code, register **warranty**.

