

Assembly Instructions

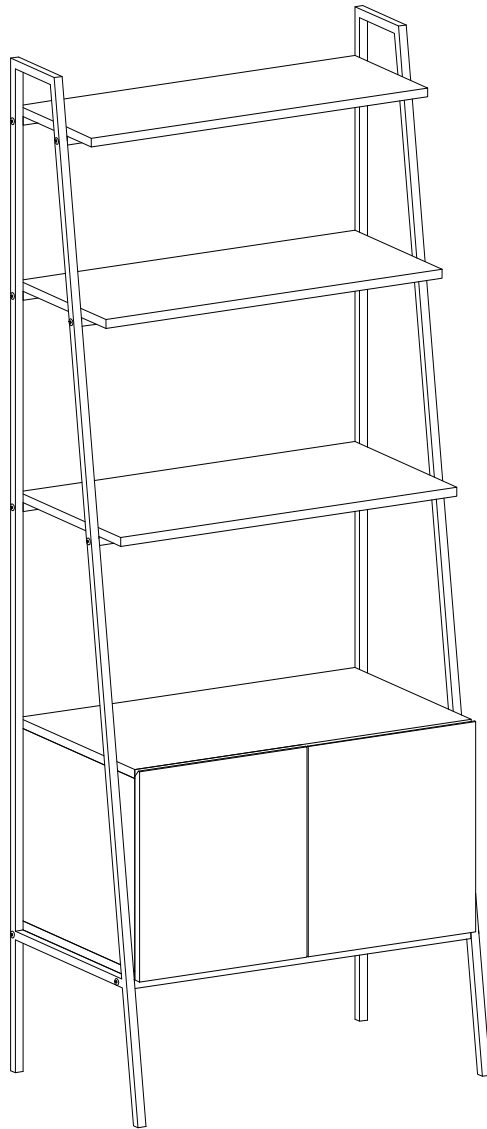

General Assembly Guidelines

- I. Ensure that all parts and hardware are available before beginning assembly.
- II. Follow each step carefully to ensure the proper assembly of this product.
- III. Two people are recommended for ease in the assembly of this product.
- IV. The three main types of hardware used to assemble this product are: wood dowels, screws and bolts.
- V. The provided glue is to secure wood dowels in place. When first inserting dowels, locate the appropriate hole for the dowel, place a small amount of glue in the hole and insert the dowel. Wipe away excess glue immediately.

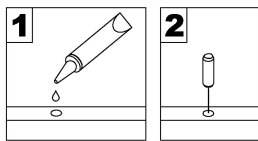

In future assembly steps when dowels are necessary to attach assembly parts together, place a small amount of glue on the end of the dowel before attaching parts together. Wipe away excess glue immediately.

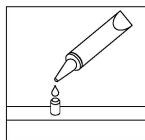

- VI. A head screwdriver is required for the assembly of this product.

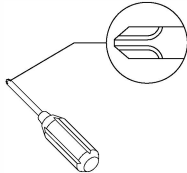

- VII. Power tools should not be used to assemble this product.

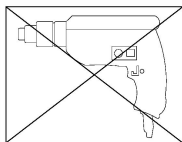

- VIII. Drill may be needed for securing product to wall.

- IX. Concealed hinges are three-way adjustable.

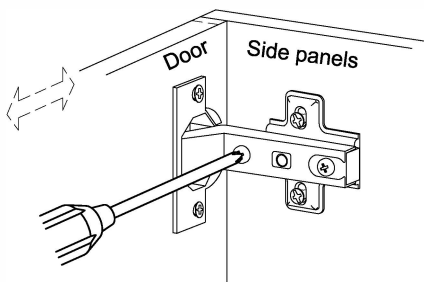

Horizontal
by screw adjustment

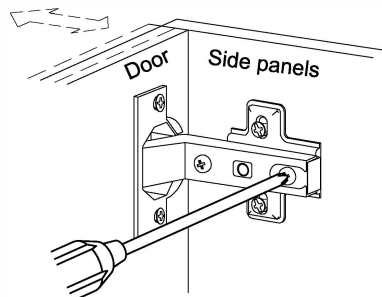

In-and-Out
by loosening the hinge-arm
mounting screw or via cam
adjustment

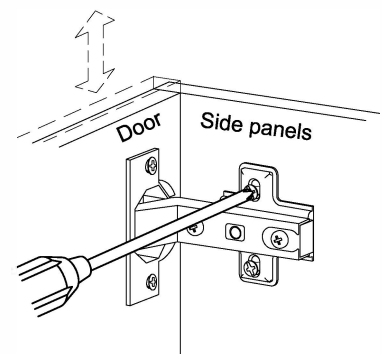





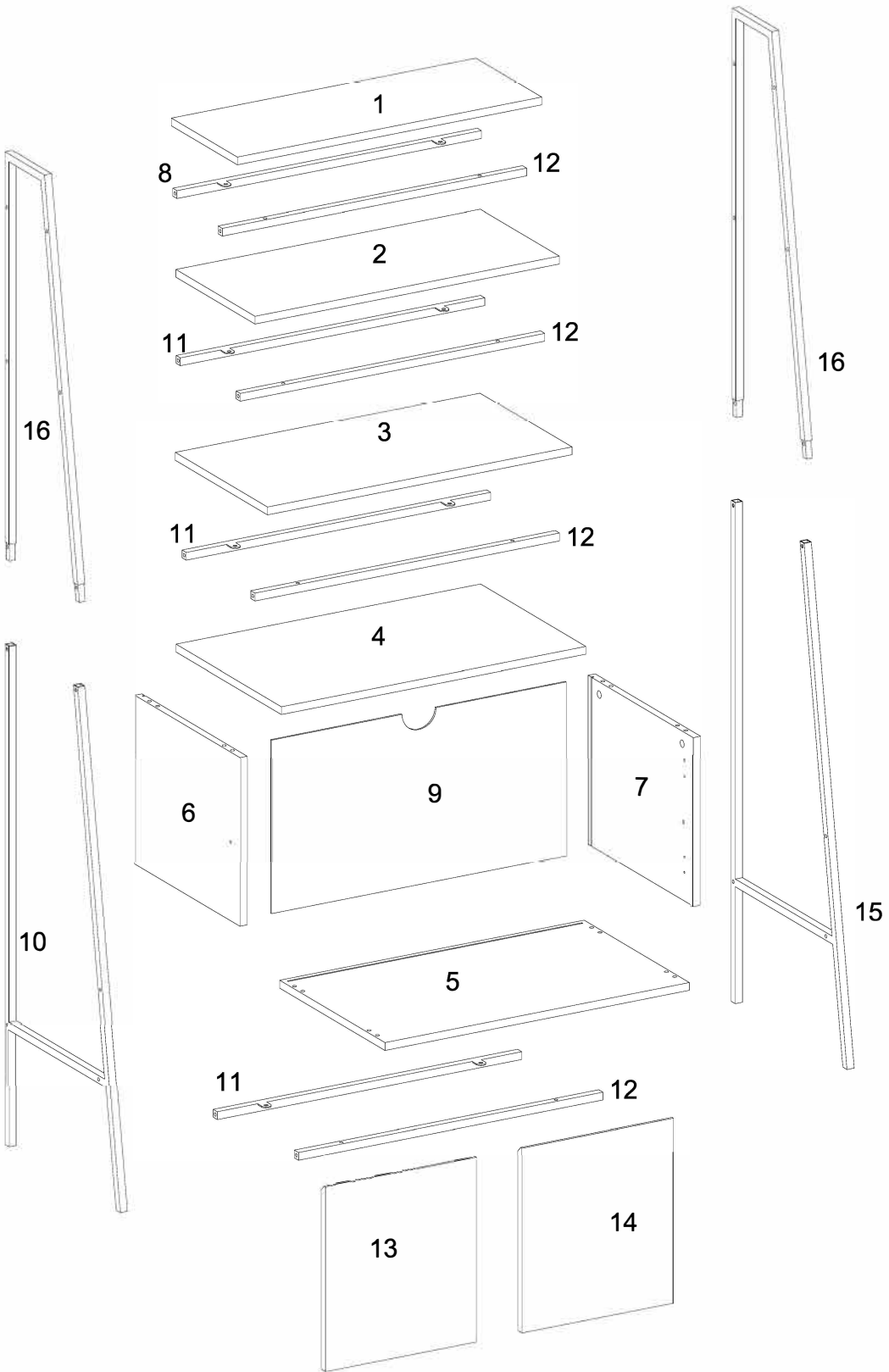









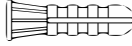

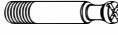

Vertical
Via slots in the mounting
plate or via cam adjustment

Parts List



Hardware List

A		Ø1/4"x12mm	Bolt	9 pcs
B		Ø1/4"x25mm	Bolt	24 pcs
C		4 mm	Hex Key	1 pcs
D		Ø16x6.5x1.0mm	Washer	1 pcs
E		40x25x20mm	Bracket	1 pcs
F		Ø4x30mm	Screw	1 pcs
G			Wall anchor	1 pcs
H		Ø6x50mm	Bolt	4 pcs
J		Ø8x30mm	Wooden dowel	8 pcs
K		Ø15x9.5mm	Cam lock	4 pcs
L		Ø6x32mm	Cam bolt	4 pcs
M		Ø30mm	Sticker	4 pcs
N		Ø3x17mm	Screw	4 pcs
P		Ø4x12mm	Screw	20 pcs
Q			Plastic wedge	4 pcs
R			Plate	2 pcs
S			Glue tube	1 pcs
T		Ø1/4"x20mm	Bolt	2 pcs
U			Hinge	4 pcs

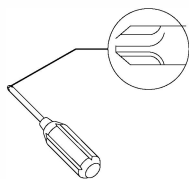

head screwdriver required for assembly
(not included)

*The hardware quantities listed above are required for proper assembly.
Some extra hardware may also have been included.*

Step 1

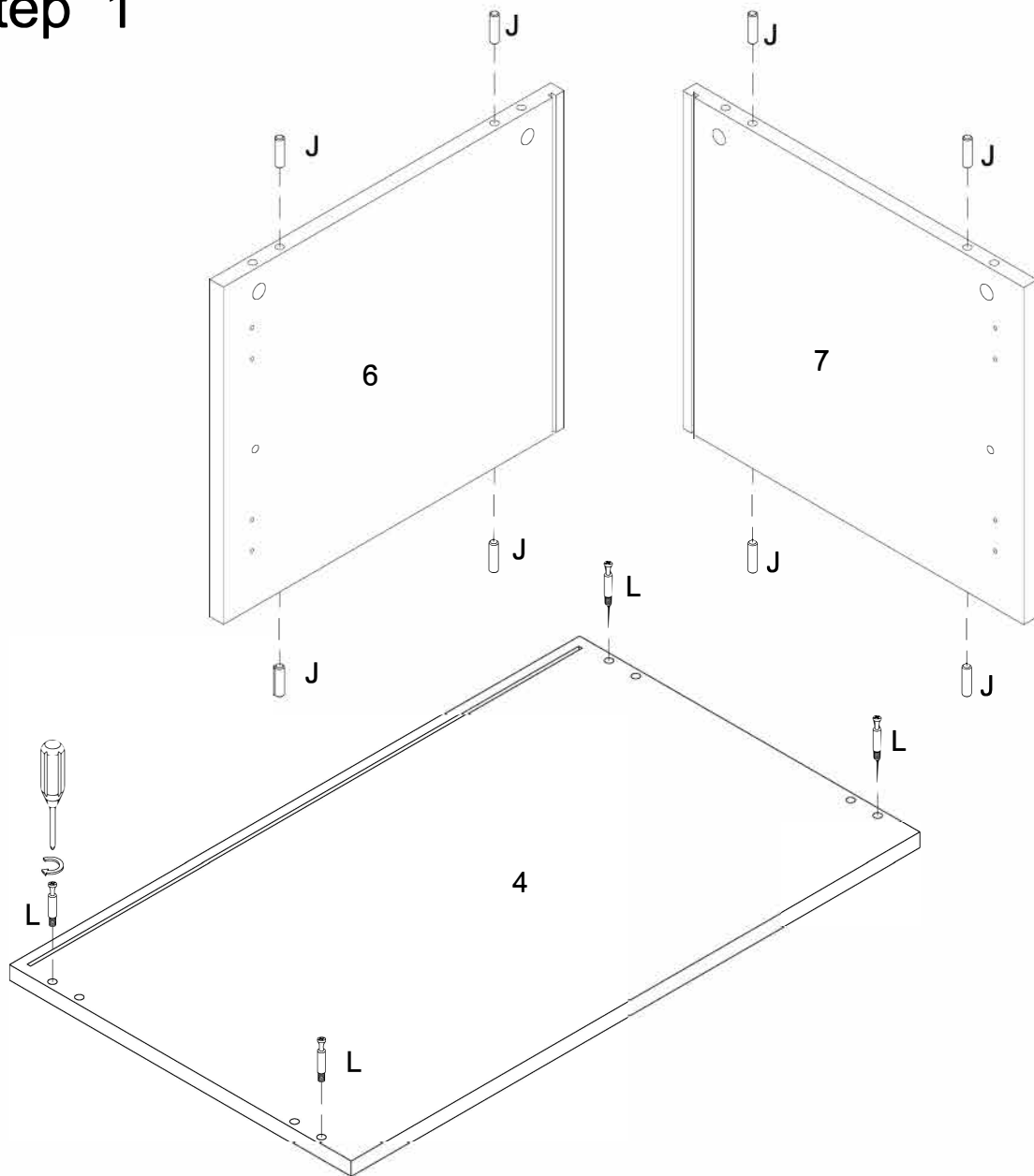

Insert wooden dowel(J) into part (6,7), secure cam bolt (L) to part (4) with screwdriver.

Step 2

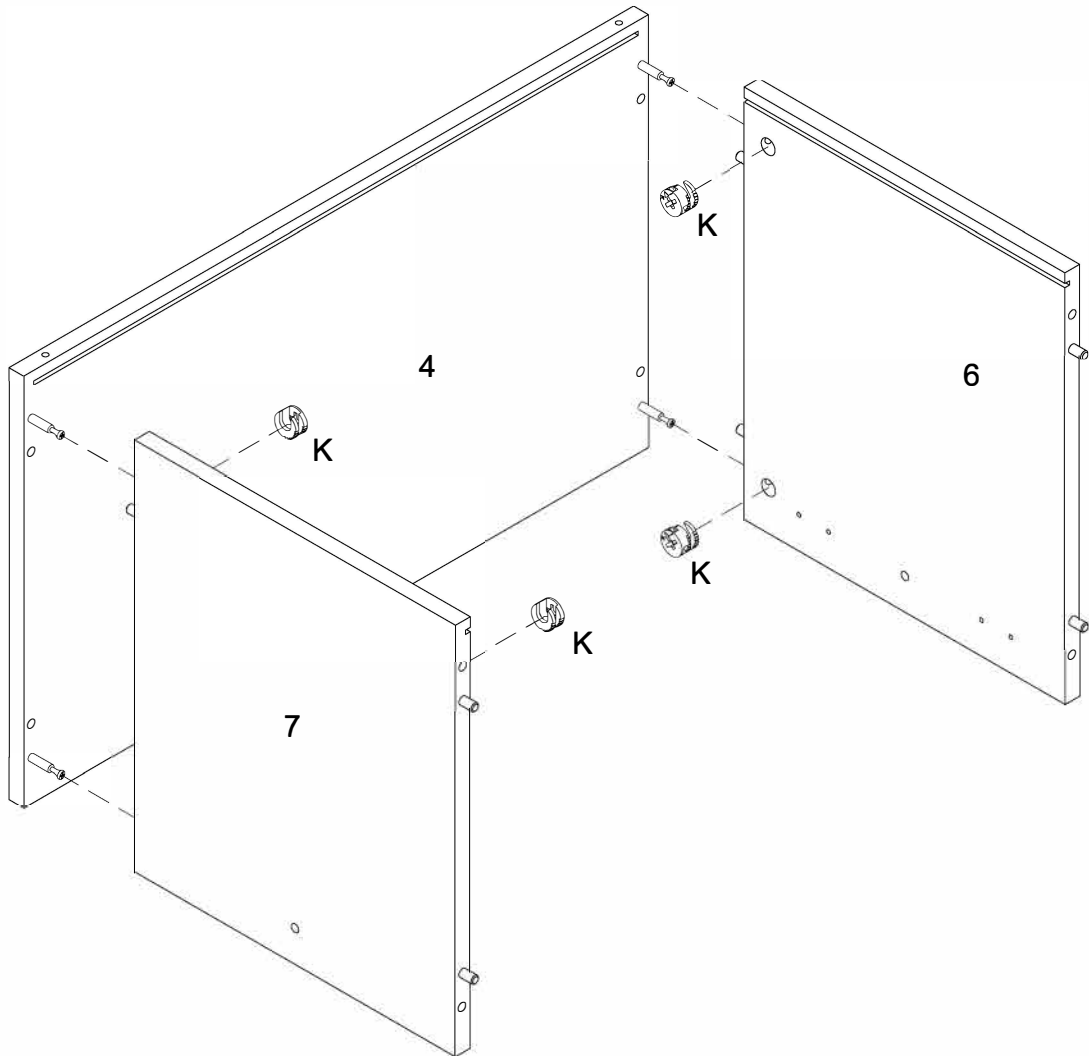
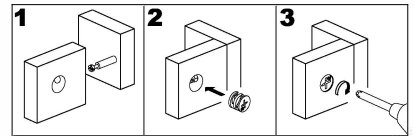

Insert part (6,7) to part (4), then secure cam lock (K) to part (6,7) with screwdriver.

Step 3

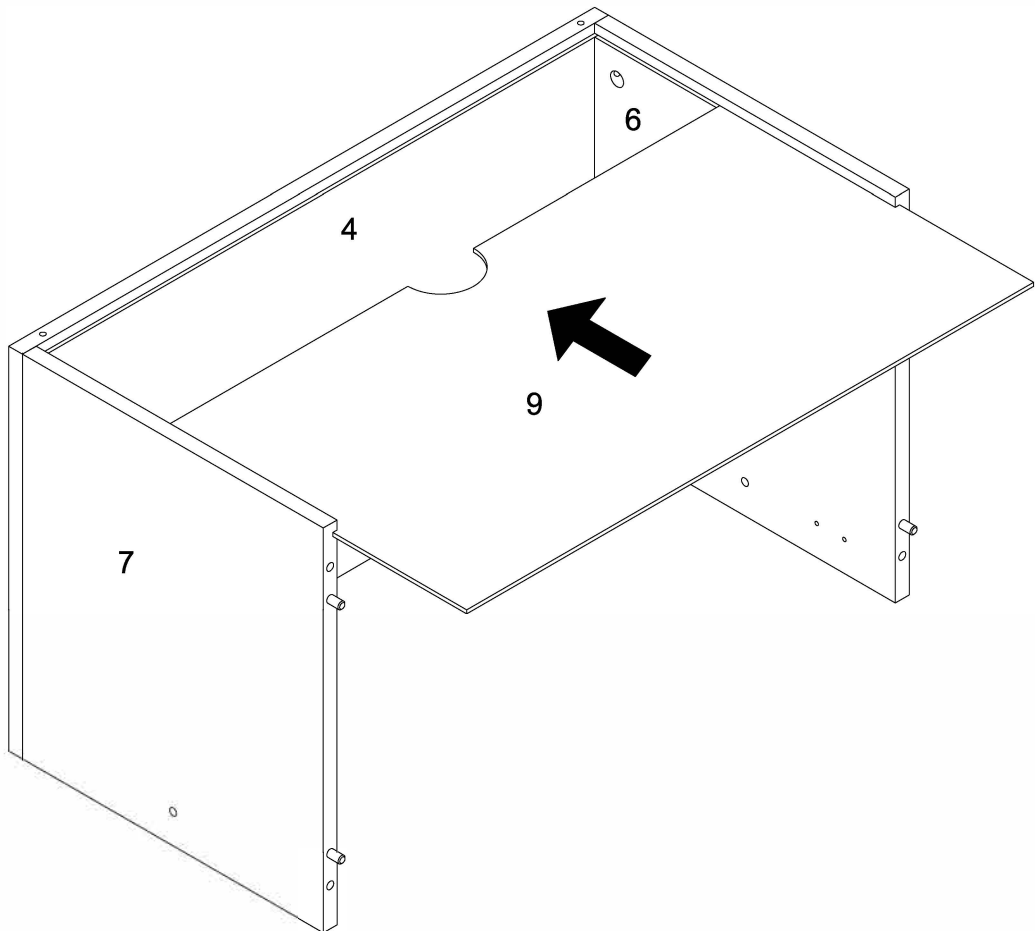

Insert part (9) into part (4,6,7) as per diagram.

Step 4

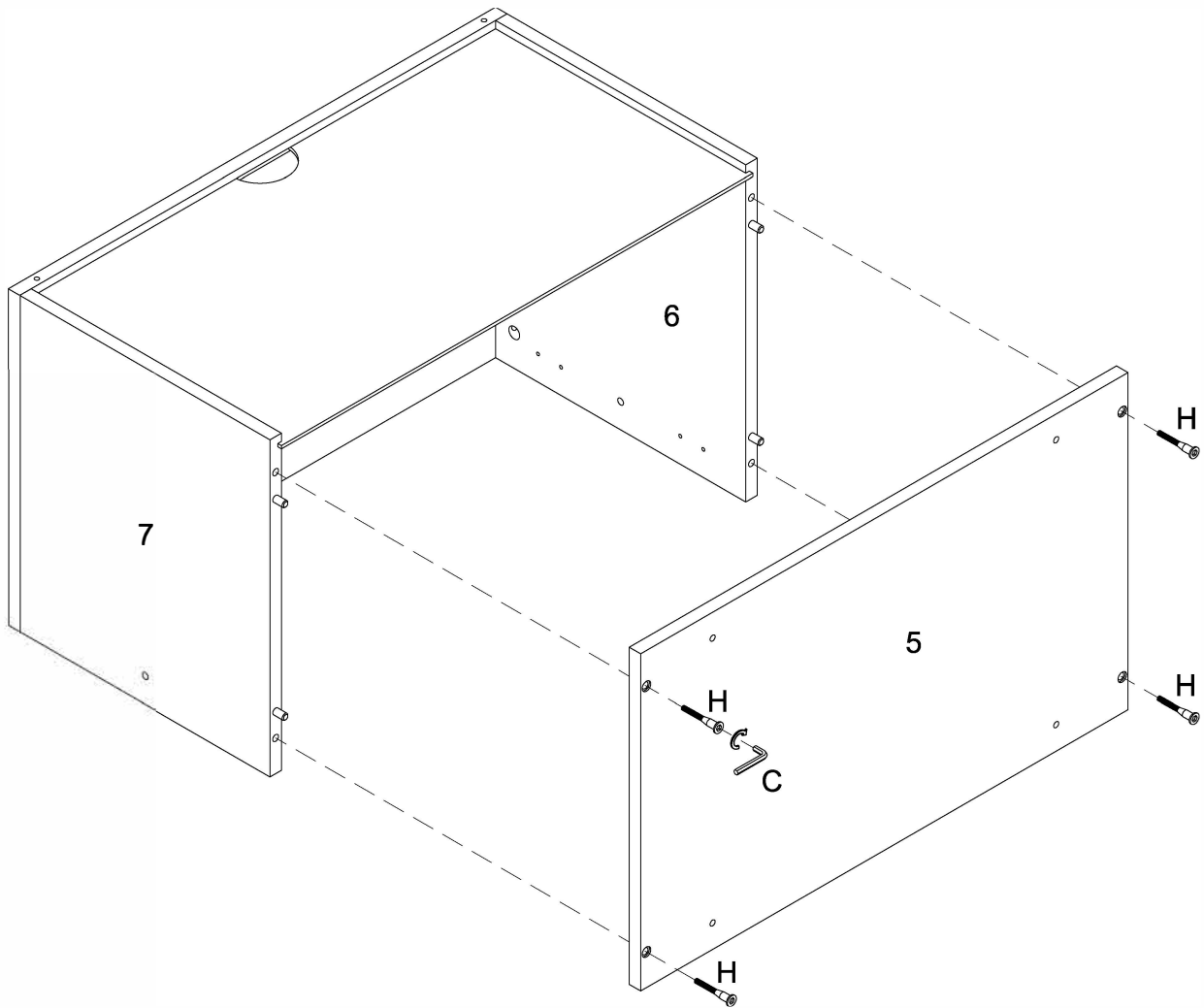

Attach part (5) to part (6,7) using bolt (H) with hex key (C).

Step 5

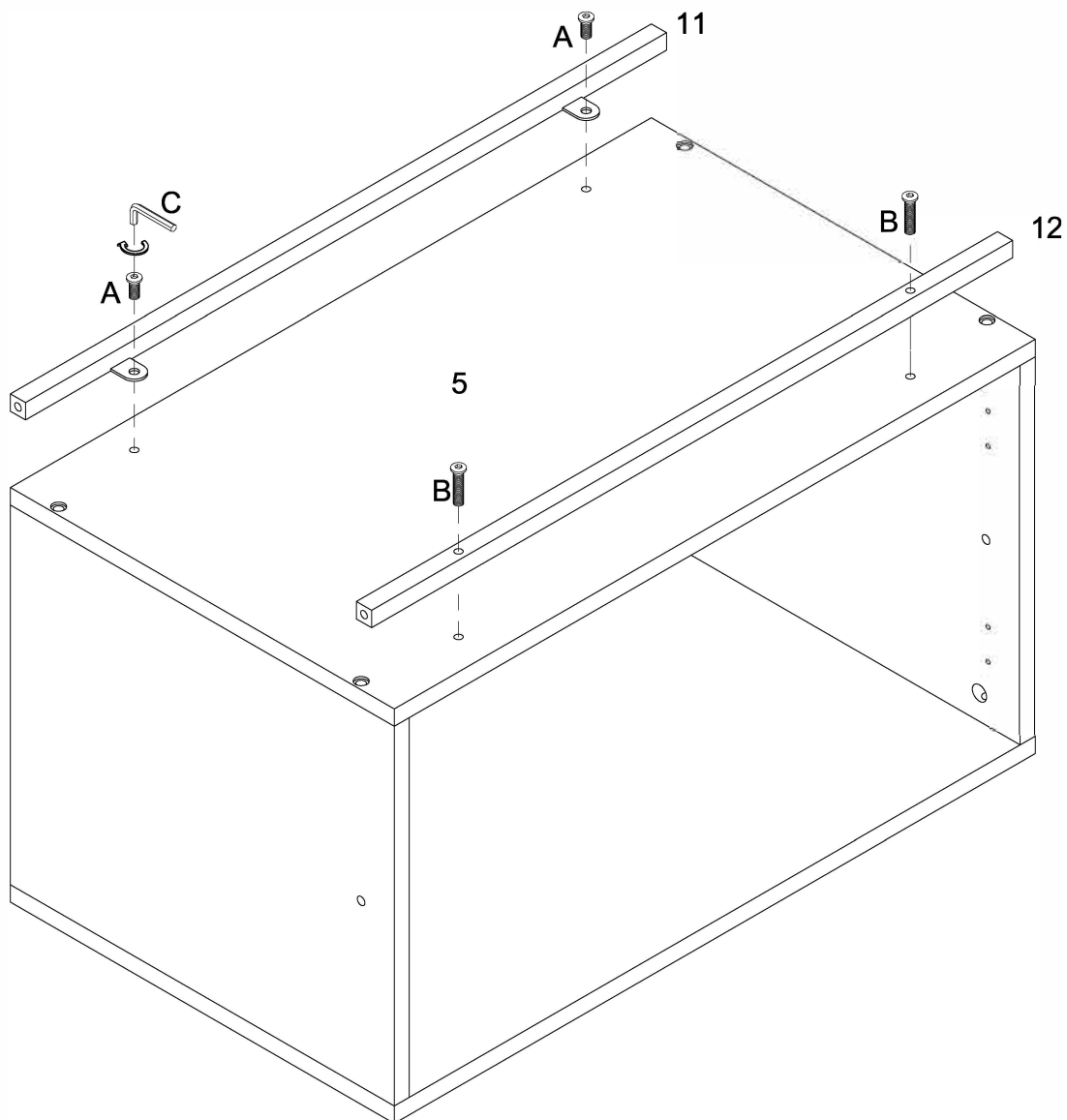

Attach part (11,12) to part (5) using bolt (A,B) with hex key (C).

Step 6

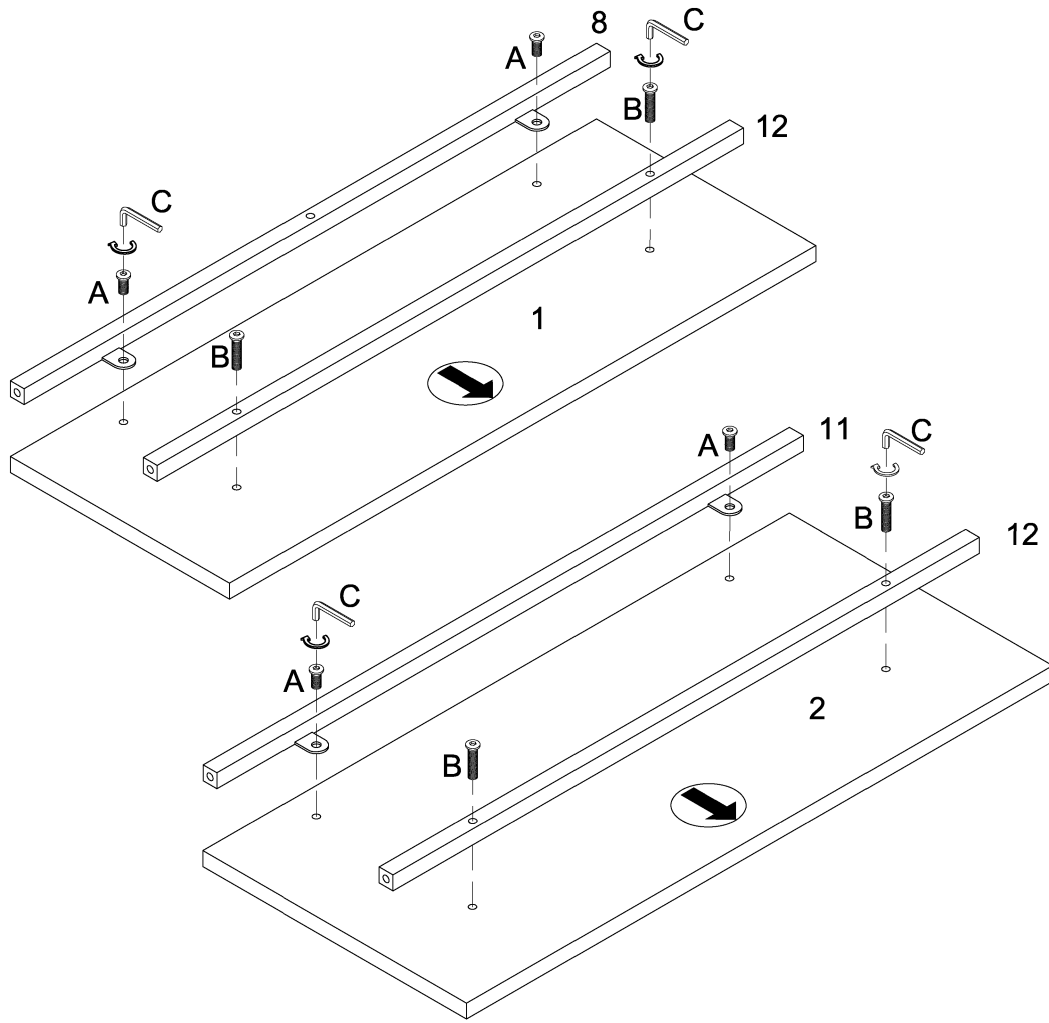

Attach part (8,11,12) to part (1, 2) using bolt (A,B) with hex key (C).

Step 7

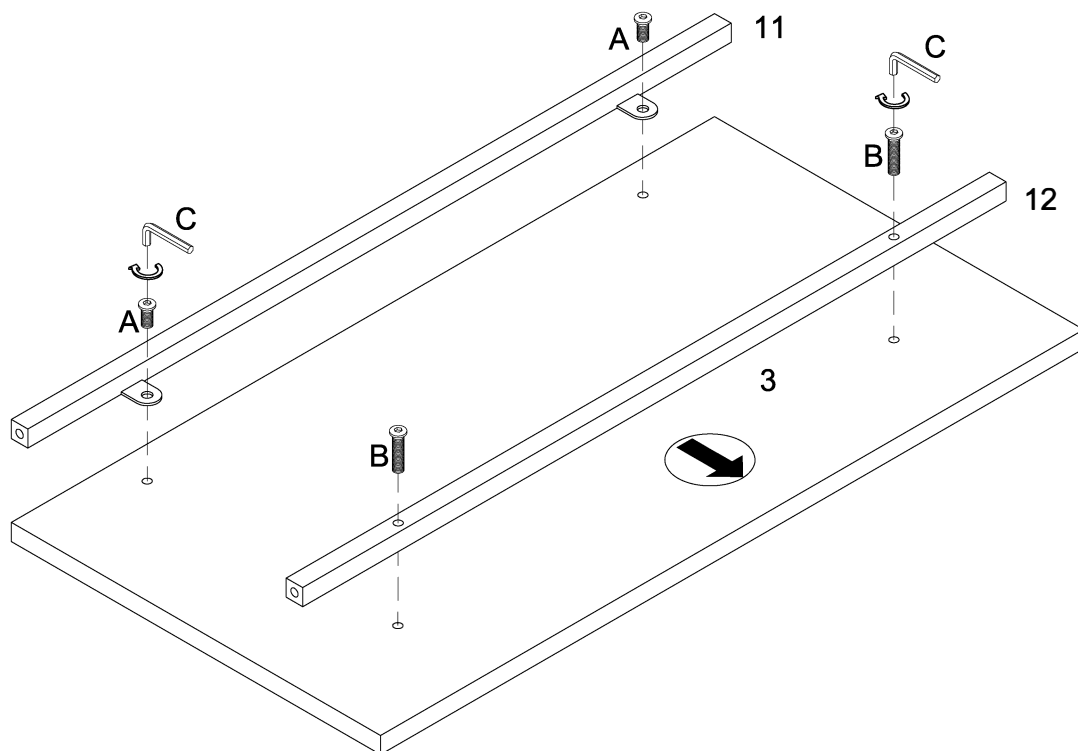

Attach part (11,12) to part (3) using bolt (A,B) with hex key (C).

Step 8

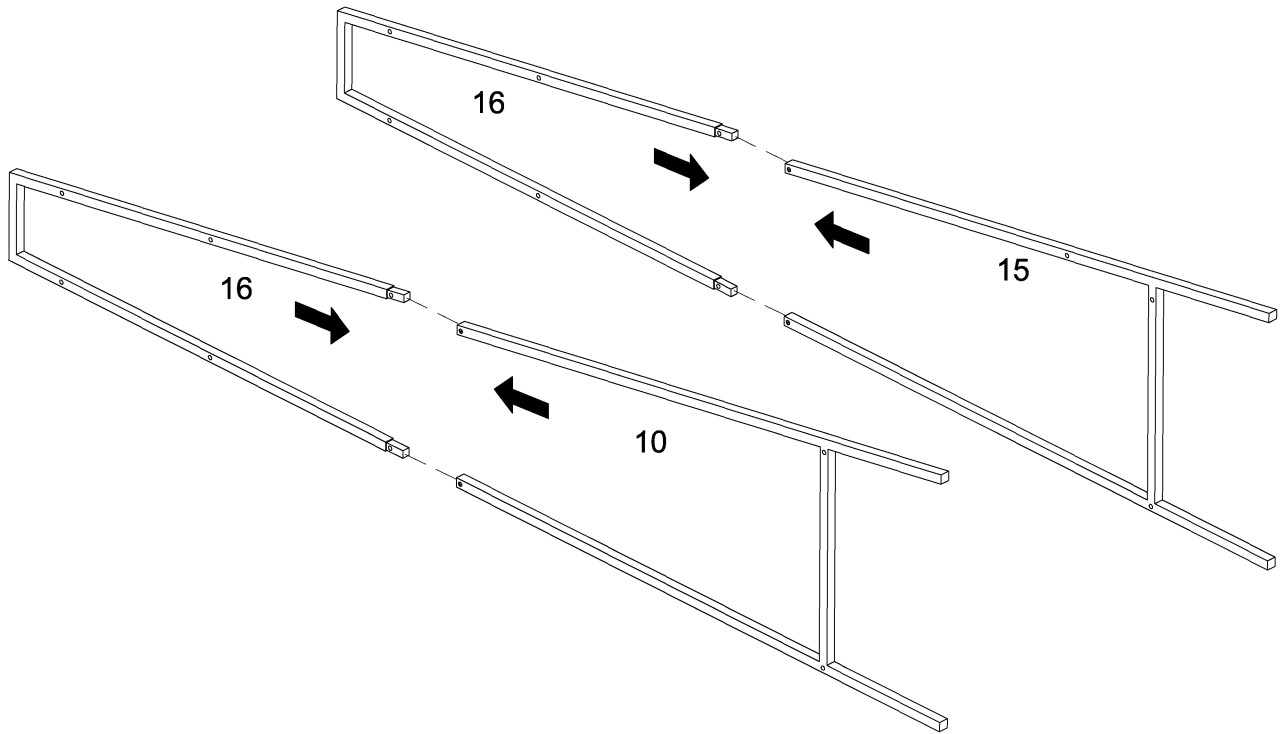

Attach part (16) to part (10,15) as per diagram.

Step 9

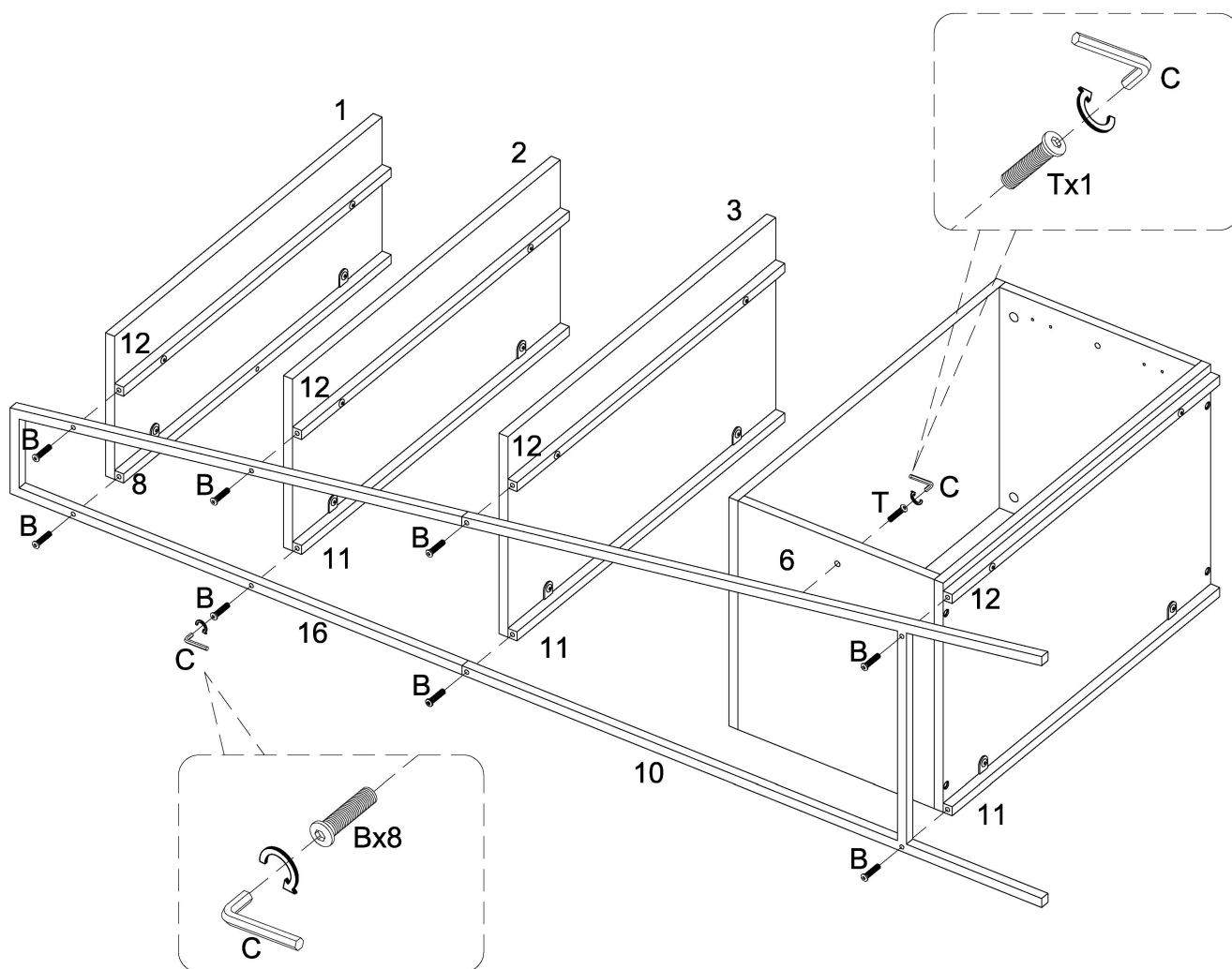

Attach part (10,16) to part (6,8,11,12) using bolt (B,T) with hex key (C).

Step 10

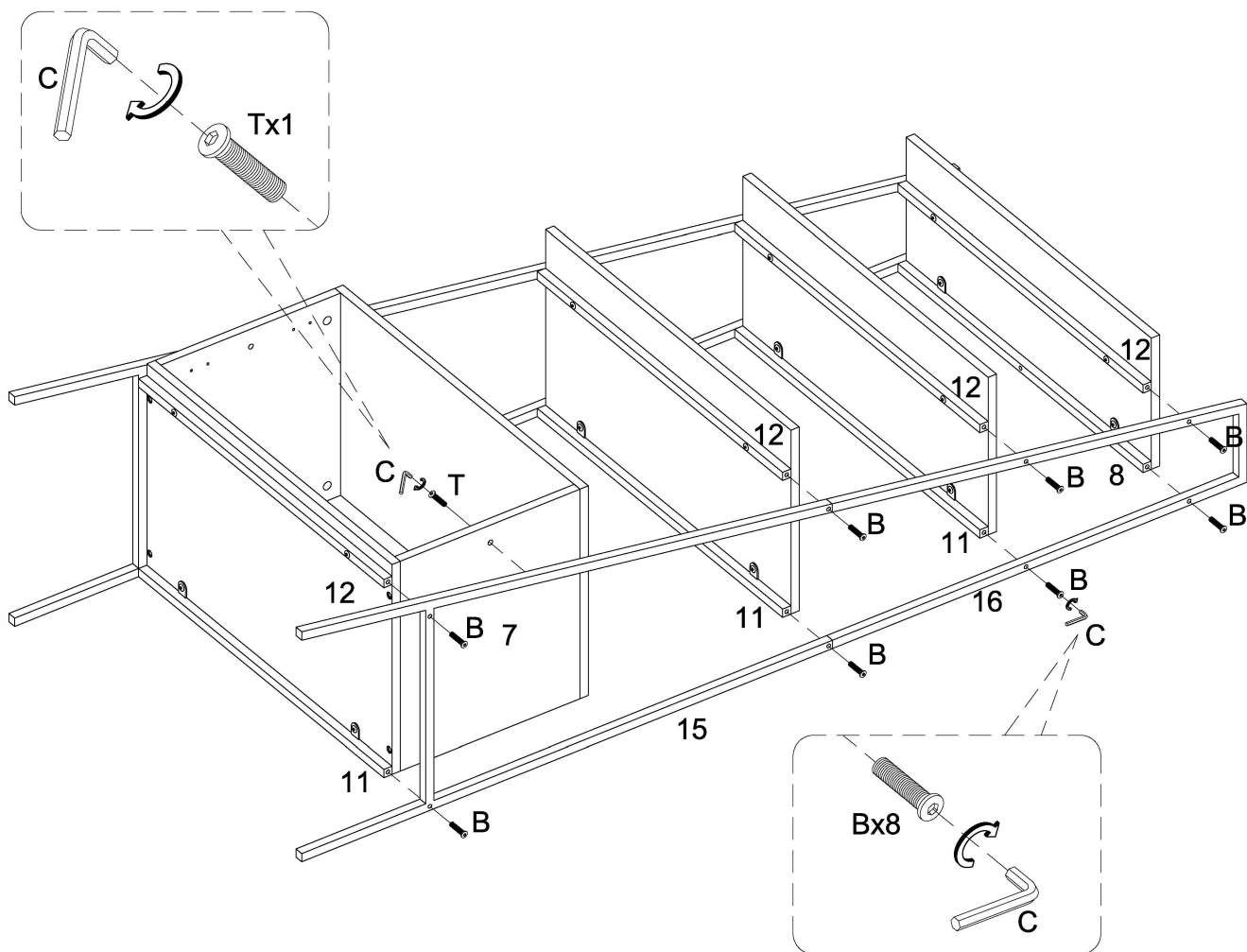

Attach part (15,16) to part (7,8,11,12) using bolt (B,T) with hex key (C).

Step 11

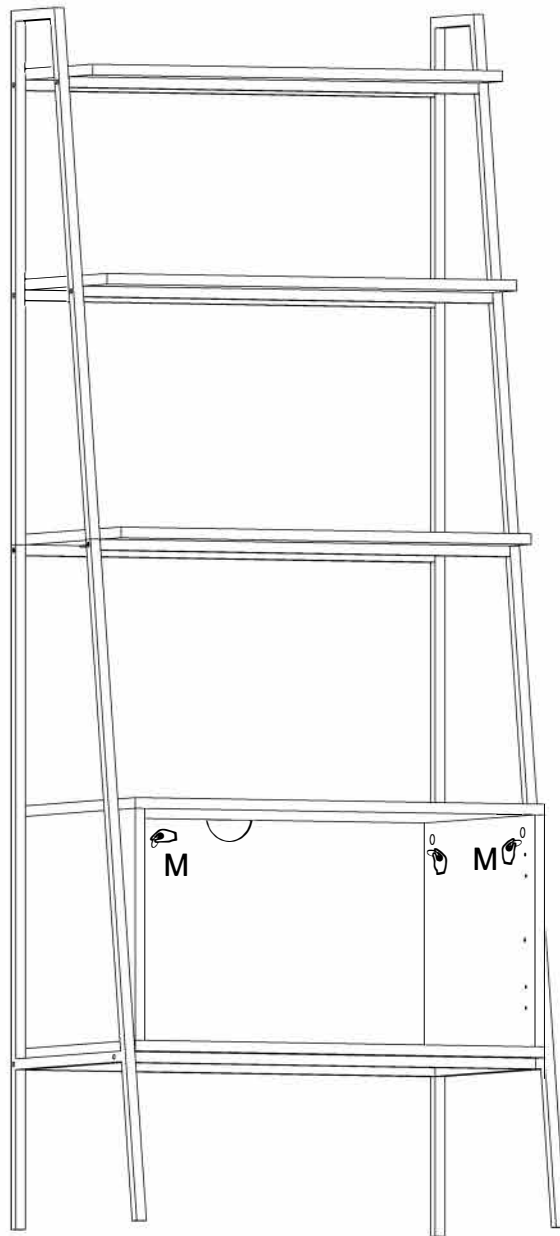

Place sticker (M) over holes as per diagram.

Step 12

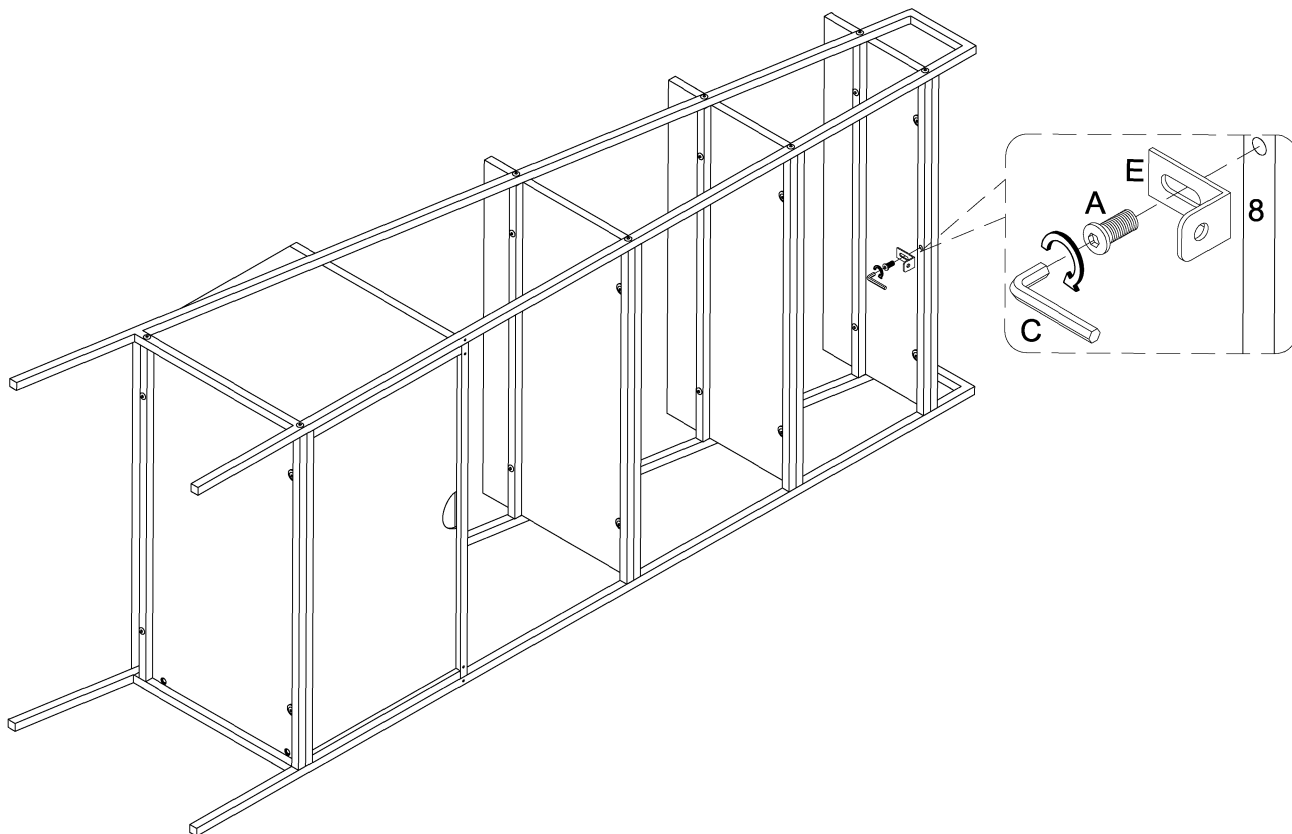

Attach bracket (E) to part (8) using bolt (A) with hex key (C).

Step 13

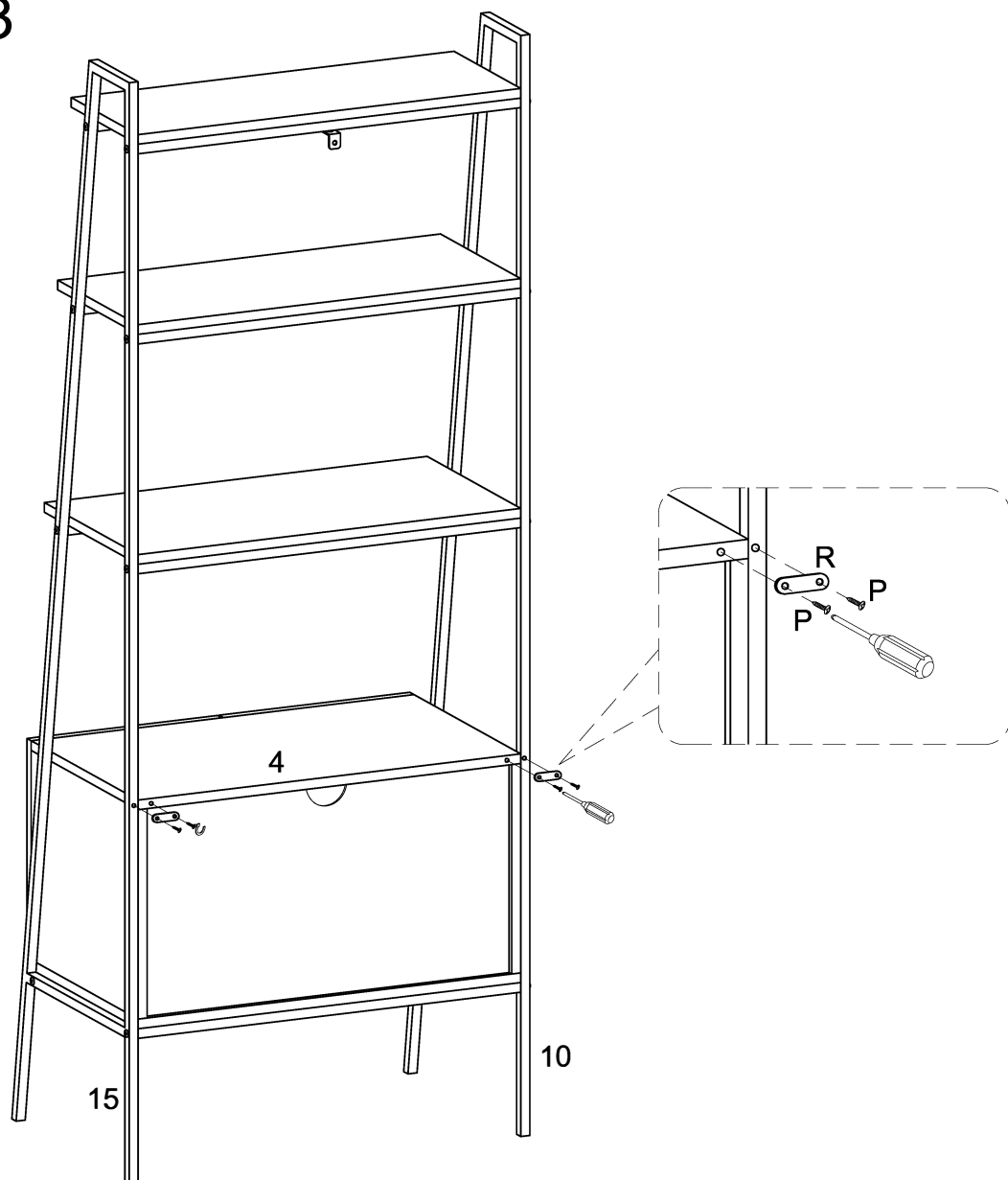

Attach plate (R) to part (4) using screw (P) with screwdriver.

Step 14

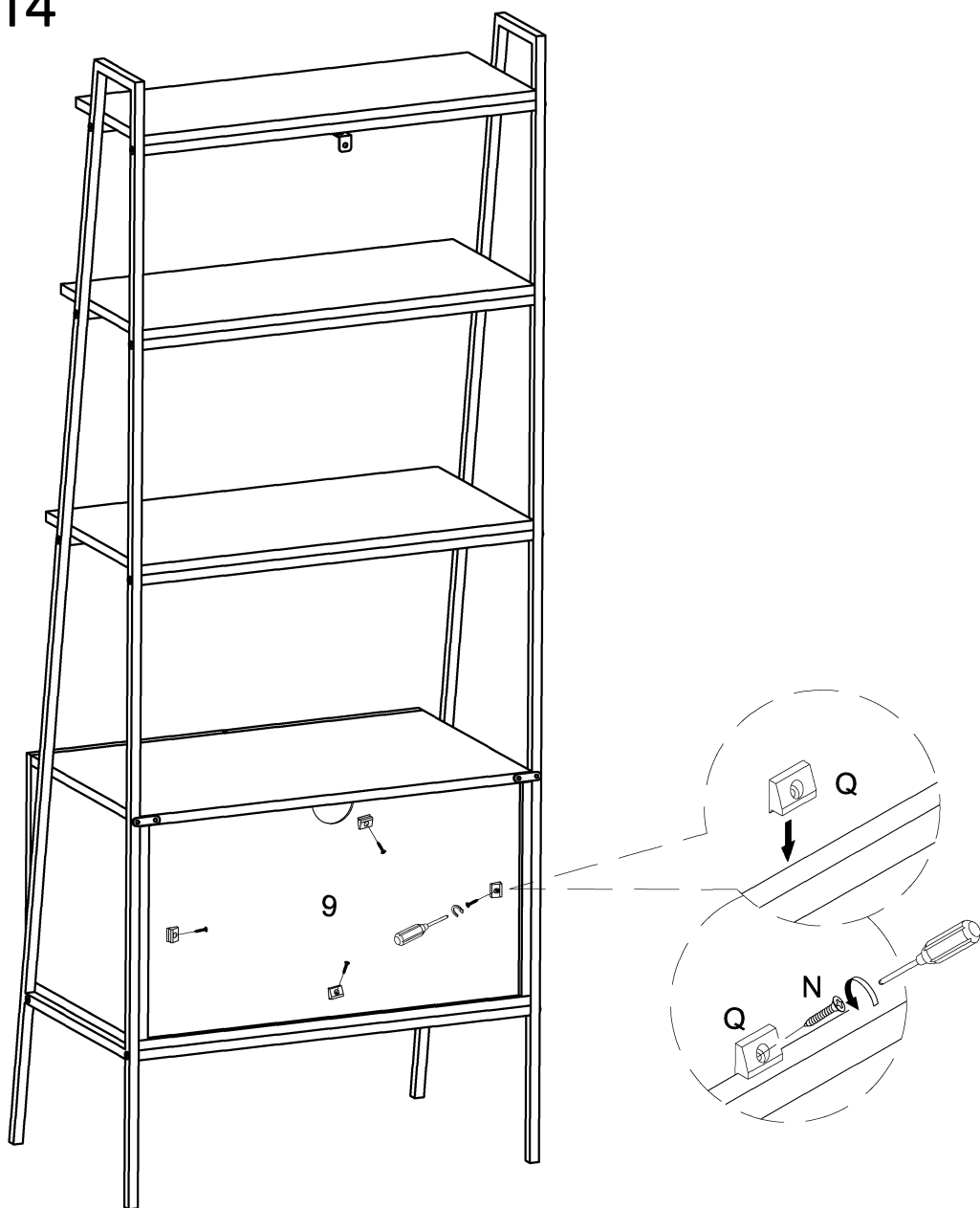

Attach plastic wedge (Q) to part (9) using screw (N) with screwdriver.

Step 15

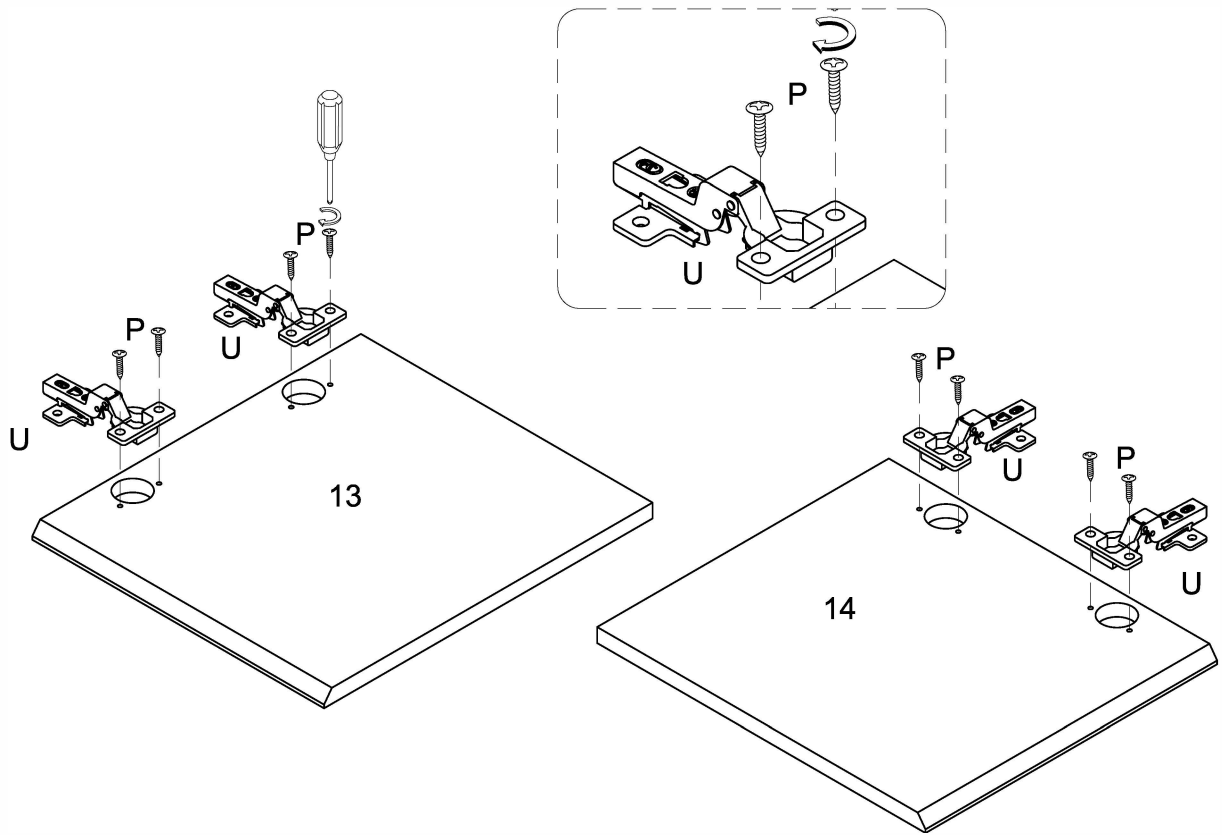

Attach hinge (U) to part (13,14) using screw (P) with screwdriver.

Step 16

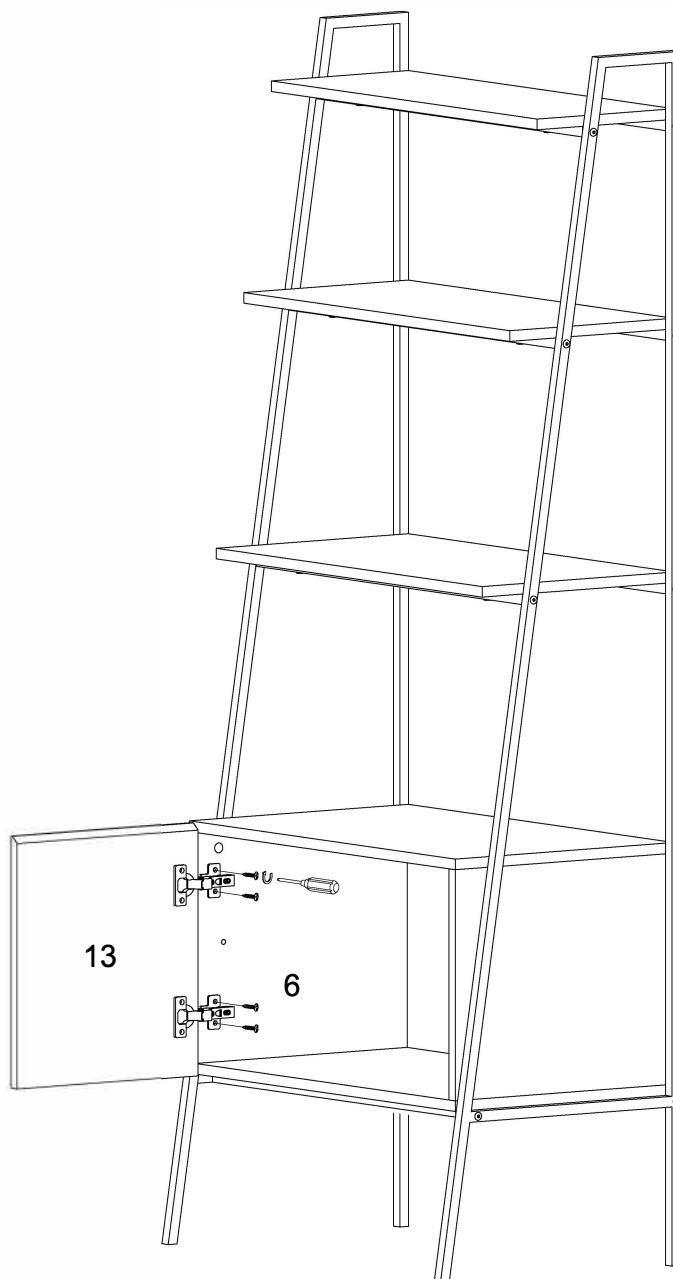
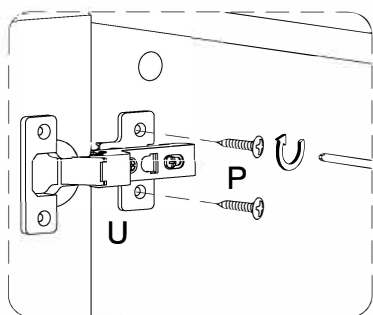

Attach part (13) to part (6) using screw (P) with screwdriver.

Step 17

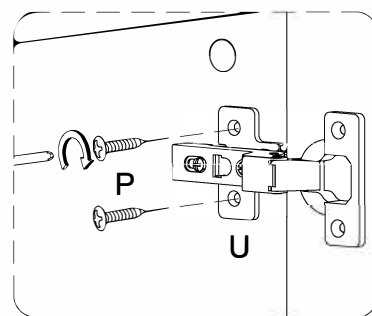
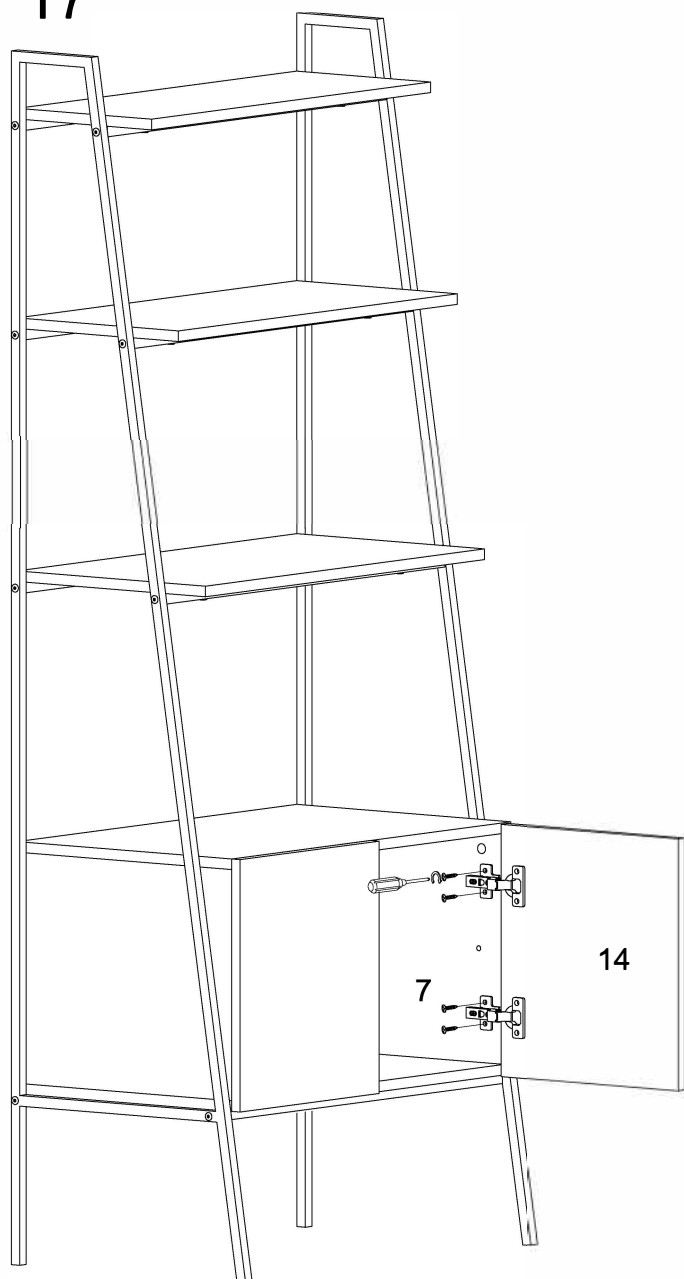

Attach part (14) to part (7) using screw (P) with screwdriver.

Step 18

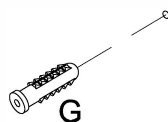
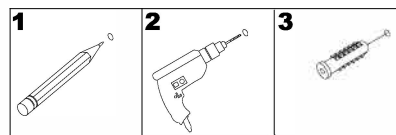

Wall

1. Measure height for bracket in desired location.
2. Drill hole using 6mm size bit.
3. Insert wall anchor (G) into wall at desired location.

*Wall anchor included for drywall mounting. Use correct wall anchor and hardware for your wall material.

Step 19

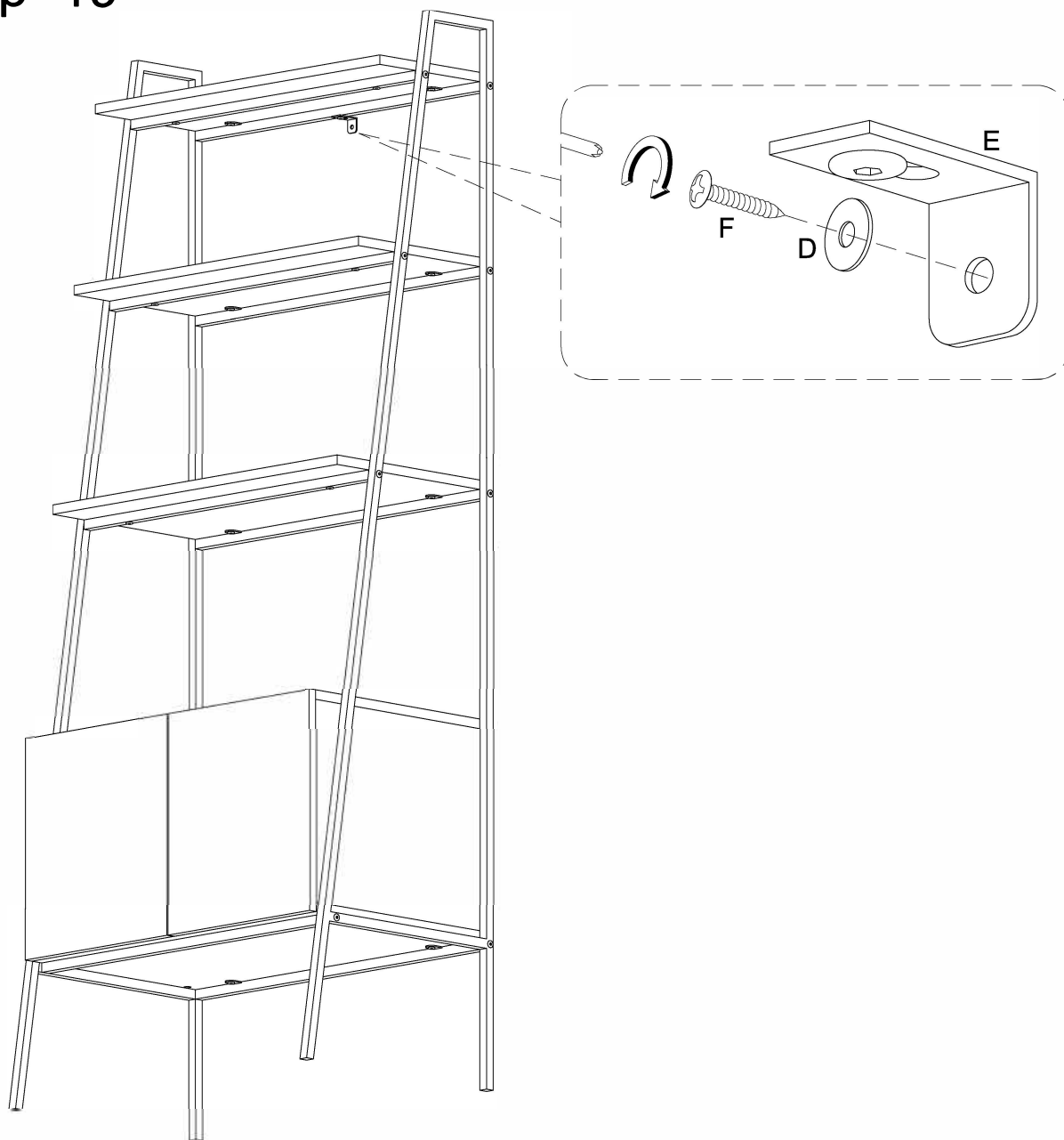

Secure furniture to wall anchor (G) in wall using washer (D) and screw (F) with screwdriver.

Step 20

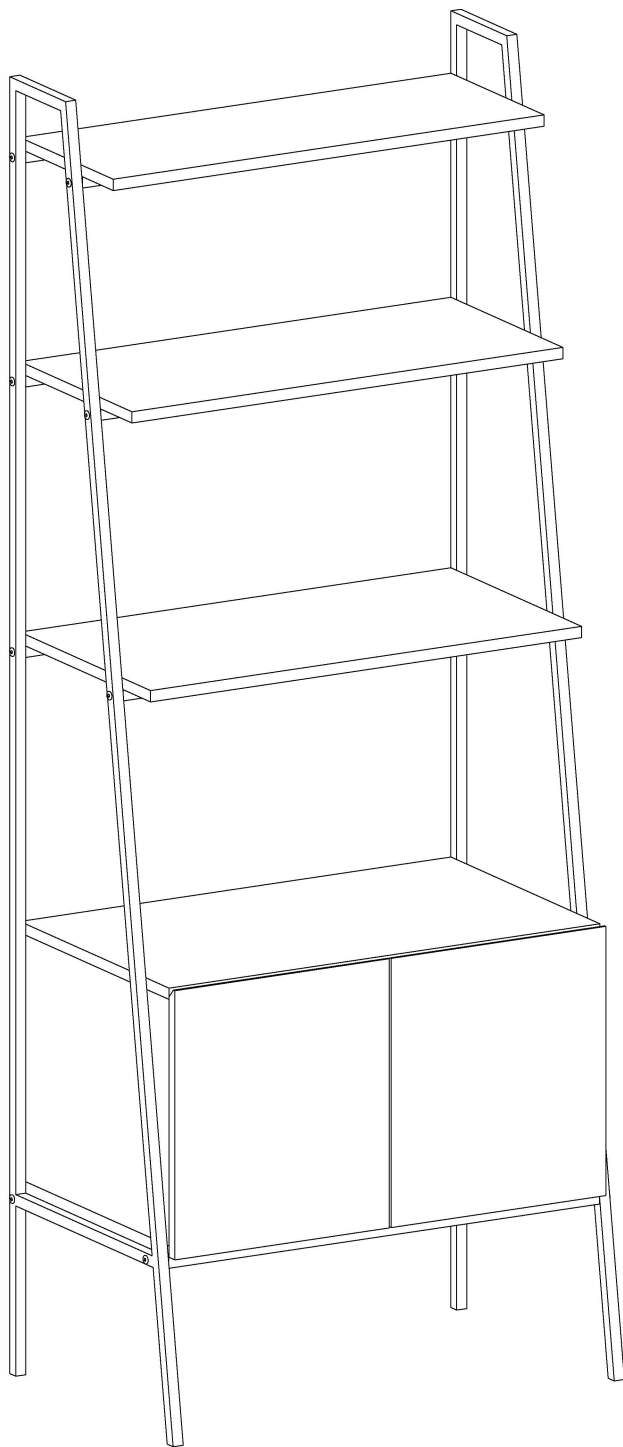

Final Assembly