

# **ASSEMBLY & CARE INSTRUCTIONS**

## **SWIVEL SOFA**

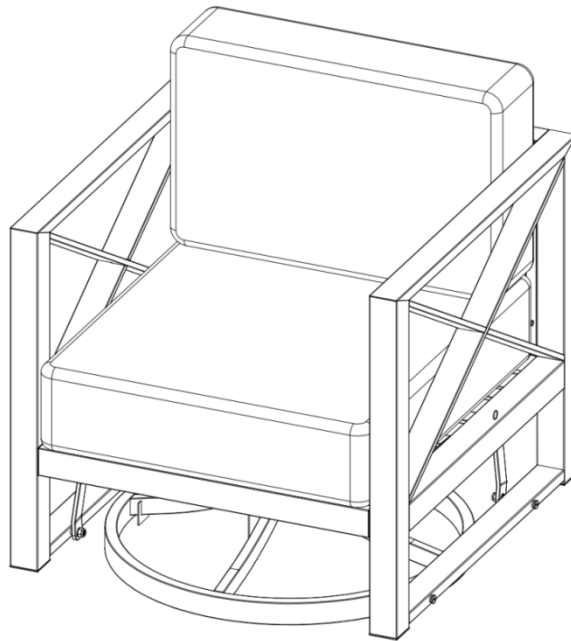

### **IMPORTANT**

**PLEASE READ BEFORE YOUR COMMENCE ASSEMBLY**

---

Follow the guidelines in this user guide to ensure correct assembly and care for this product

## **READ ALL INSTRUCTIONS BEFORE USE**

When using these furnishings, always follow basic precautions, including the following:

Read all instructions before using this set.

To reduce the risk of injury to persons:

- Do not use this set on soft ground.
- Do not stand or allow children to stand on the assembled chairs, sofa, ottoman or fire pit.
- After assembly, verify that all hardware connections are secure before putting the product into use.
- Improper installation, adjustment, alteration, service or maintenance can cause injury or property damage.
- Read all installation, operation, and maintenance instructions thoroughly before installing or servicing this equipment.

## **PLANNING ASSEMBLY**

Before beginning assembly, completely empty contents of carton and remove all packing material. Make sure all parts and hardware are present. **If any parts are missing or any questions about damaged, please contact us in time, our after sales team will reply you in 24 hours .**







Please take photos of the SKU No, and WA label before opening the boxes. Once you find something is wrong, please send us the details with above photos. That can help us to solve the problem more quickly.



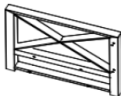

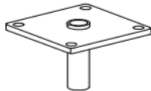

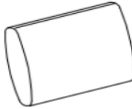
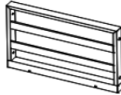

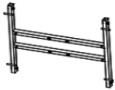



## PACKAGE CONTENTS - 1PC SWIVEL ARMCHAIR

**NOTE:** Place all parts on a soft , nonabrasive, level surface for assembly, do not over-tighten hardware connections

## SWIVEL CHAIR INSTALLATION STEPS

### SWIVEL CHAIR PART LIST

Part	Description	Qty(pcs)	Part	Description	Qty(pcs)
A		1	F		1
B		1	G		1
C		1	H		1
D		1	I		1
E		1			

Part	Description	Qty(pcs)	Part	Description	Qty(pcs)	Part	Description	Qty(pcs)
AA	 M6*35	11	FF	 M8	4	KK	 M8	8
BB	 M8*25	4	GG	 M6	1	LL		1
CC	 M8*80	4	HH	 M8	12	MM		1
DD	 M6	10	II	 M6 $\varnothing$ 29	1			
EE	 M8	4	JJ	 M6/M8	23			

**STEP 1: Connect the right armrest(A) to the base plate(C).**

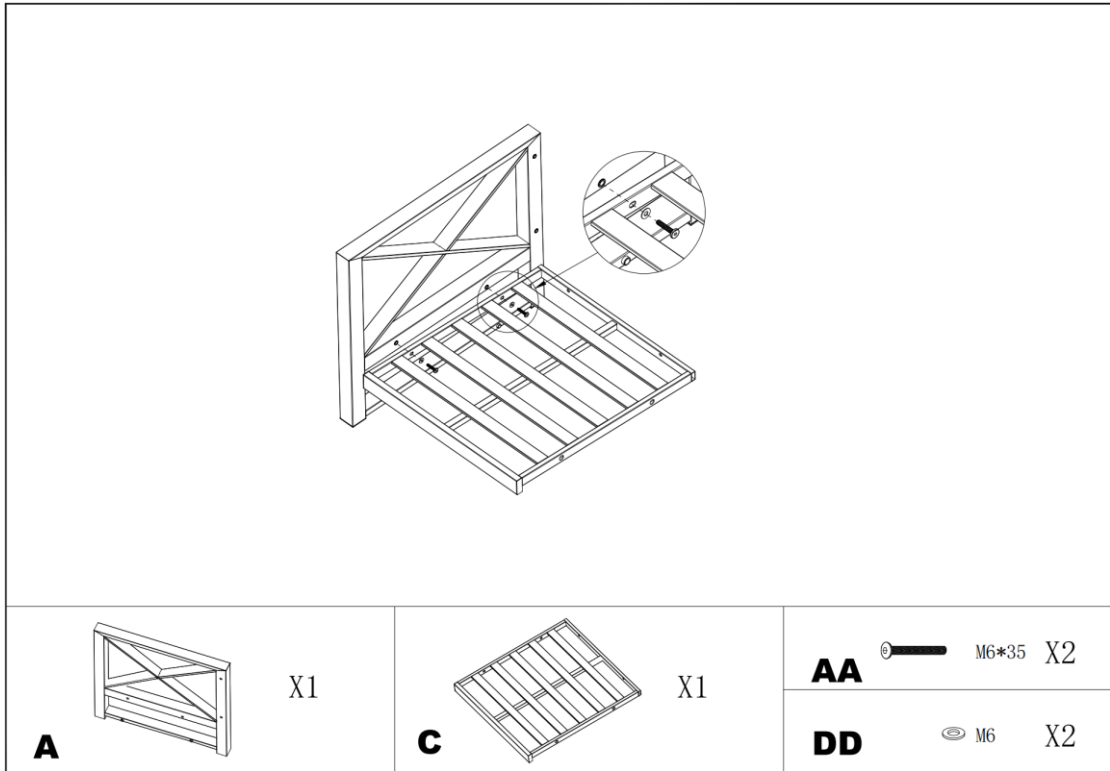

**STEP 2: Connect the left armrest(B) and base plate(C).**

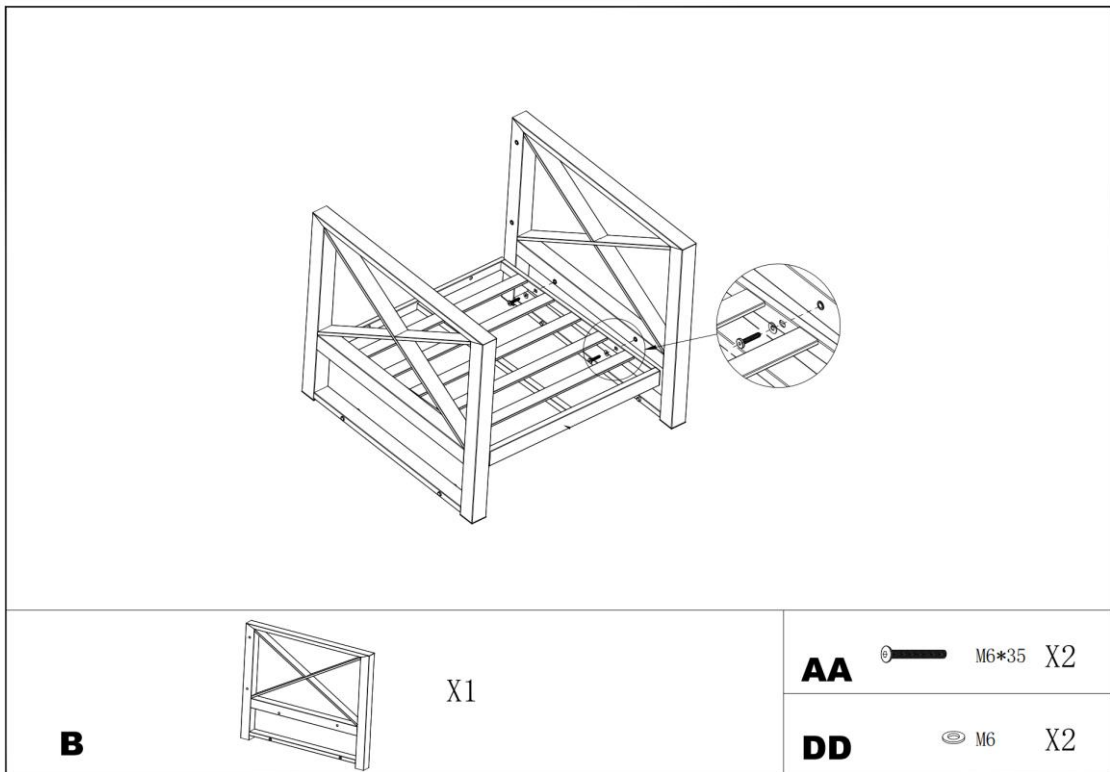

**STEP 3: Attach the backrest(D) with armrest(A&B) and seat plate.**

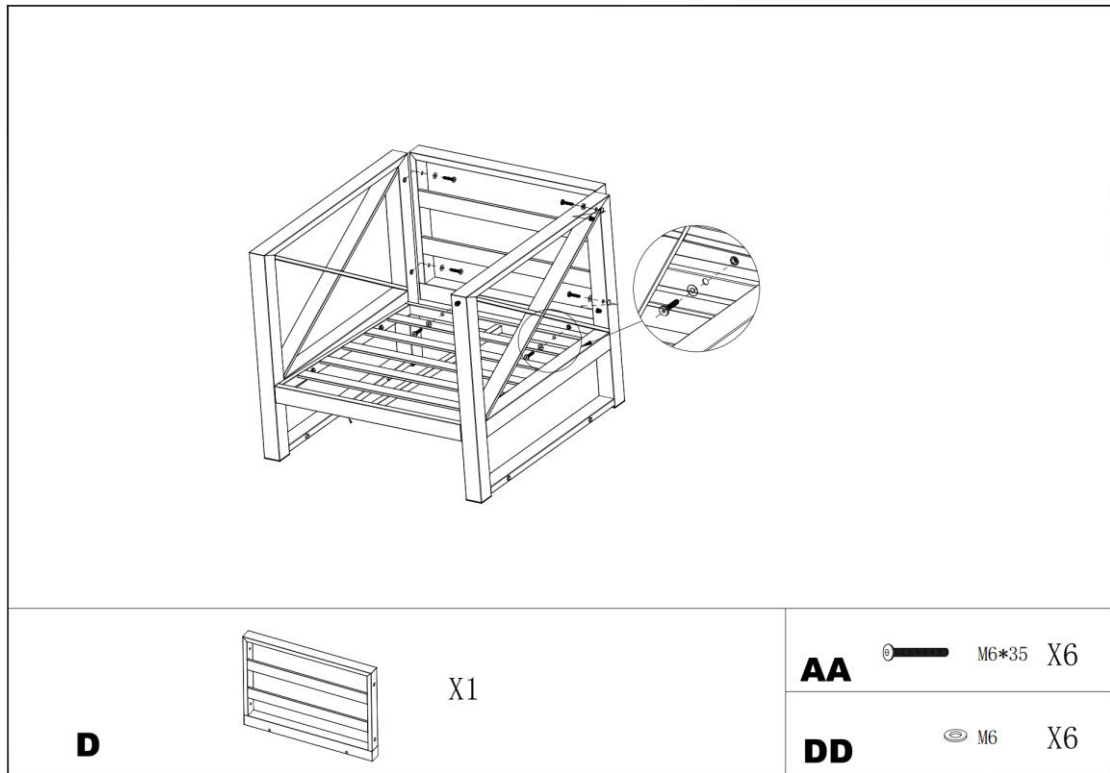

**STEP 4: Connect the H-type bracket(E) and the shaft (G).**

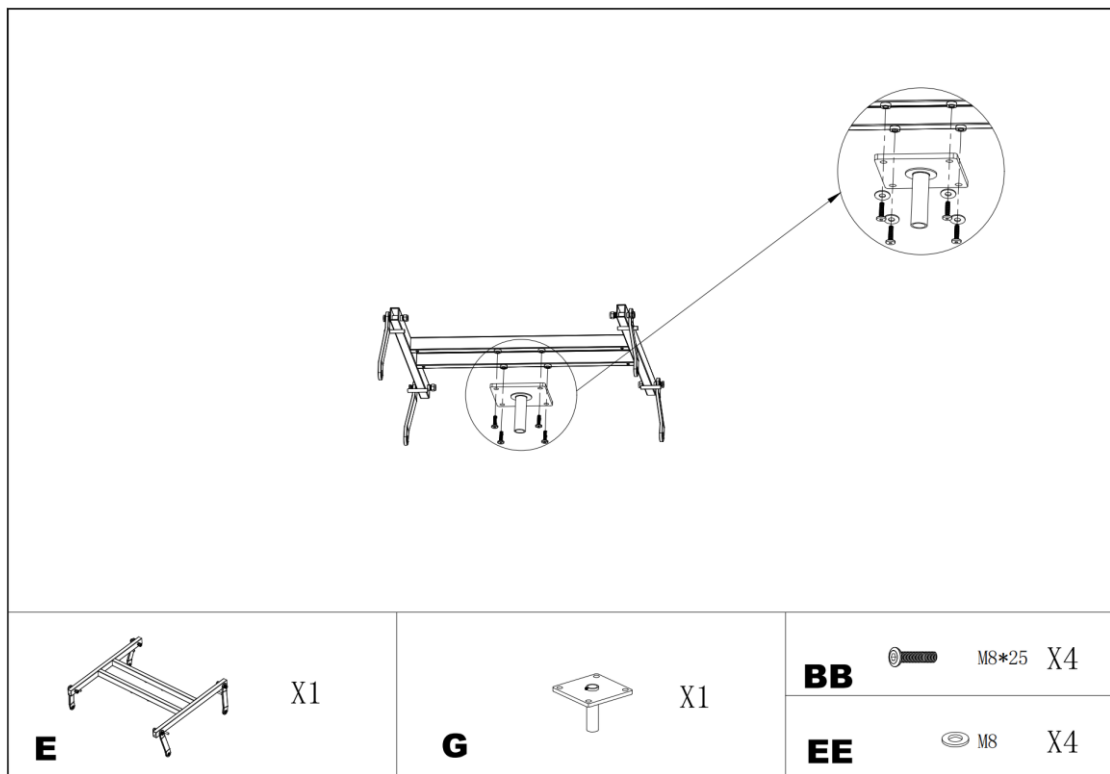

**STEP 5: Connect the shaft (G) with the chair base(F).**

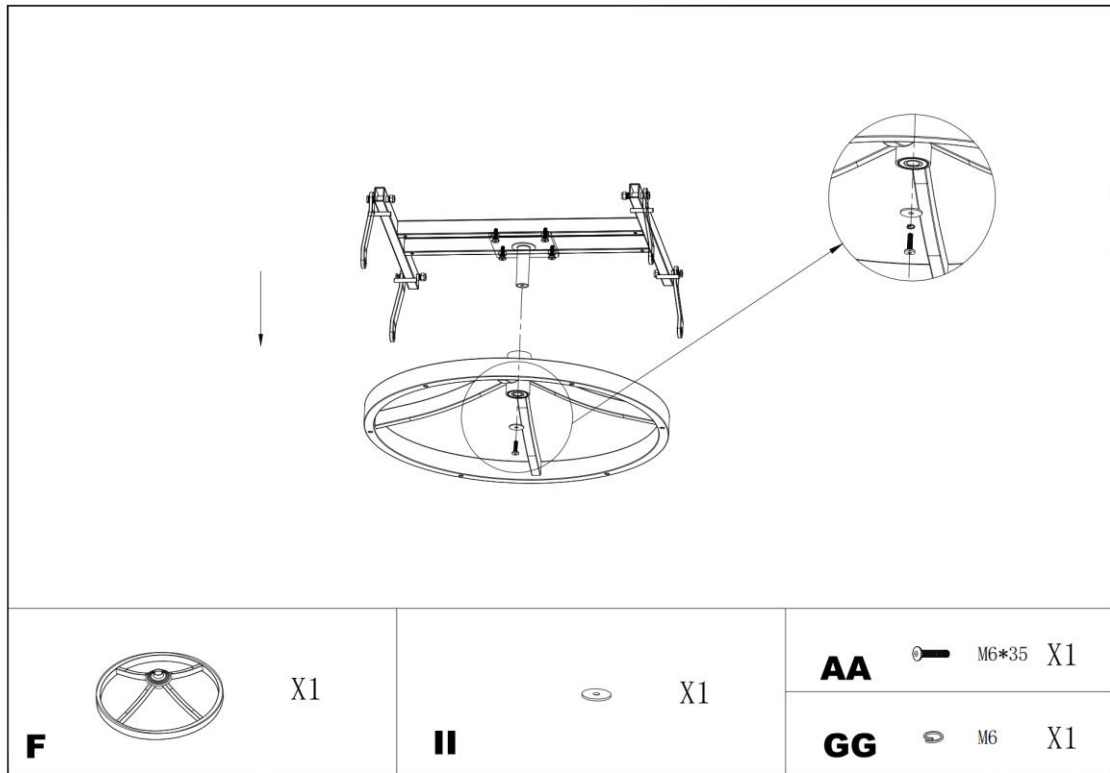

**STEP 6: Connect the chair base and the armchair.**

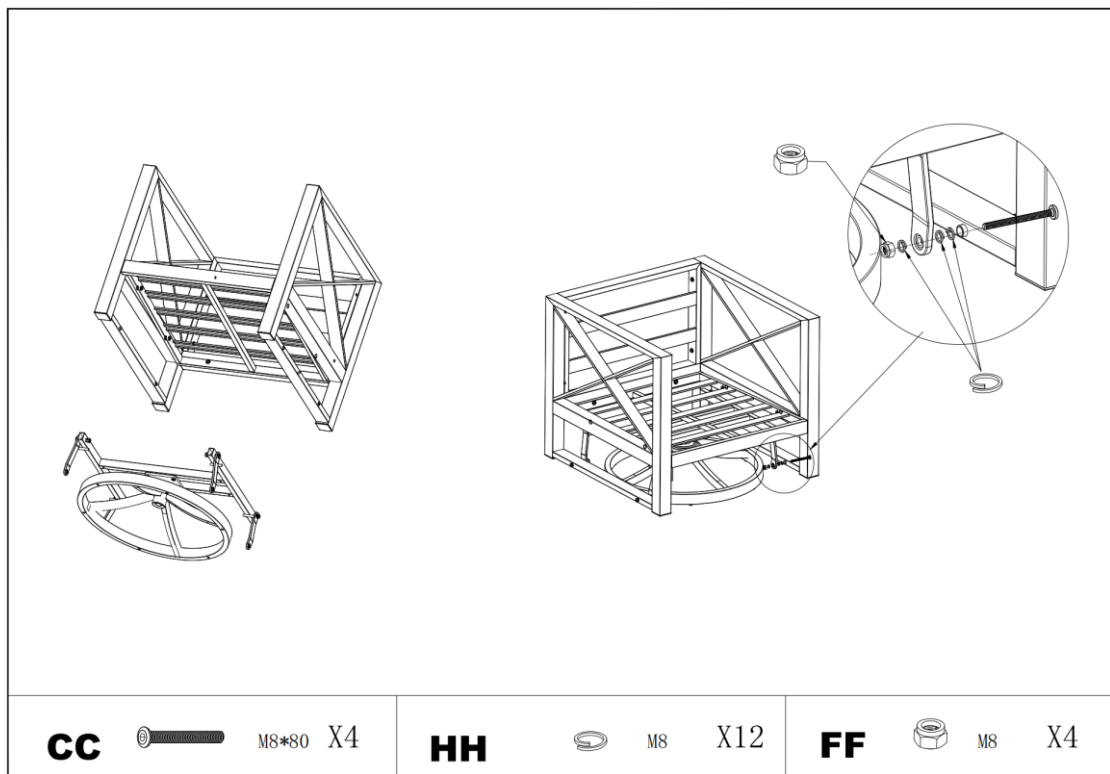

**STEP 7: Put the screw caps on the screws.**

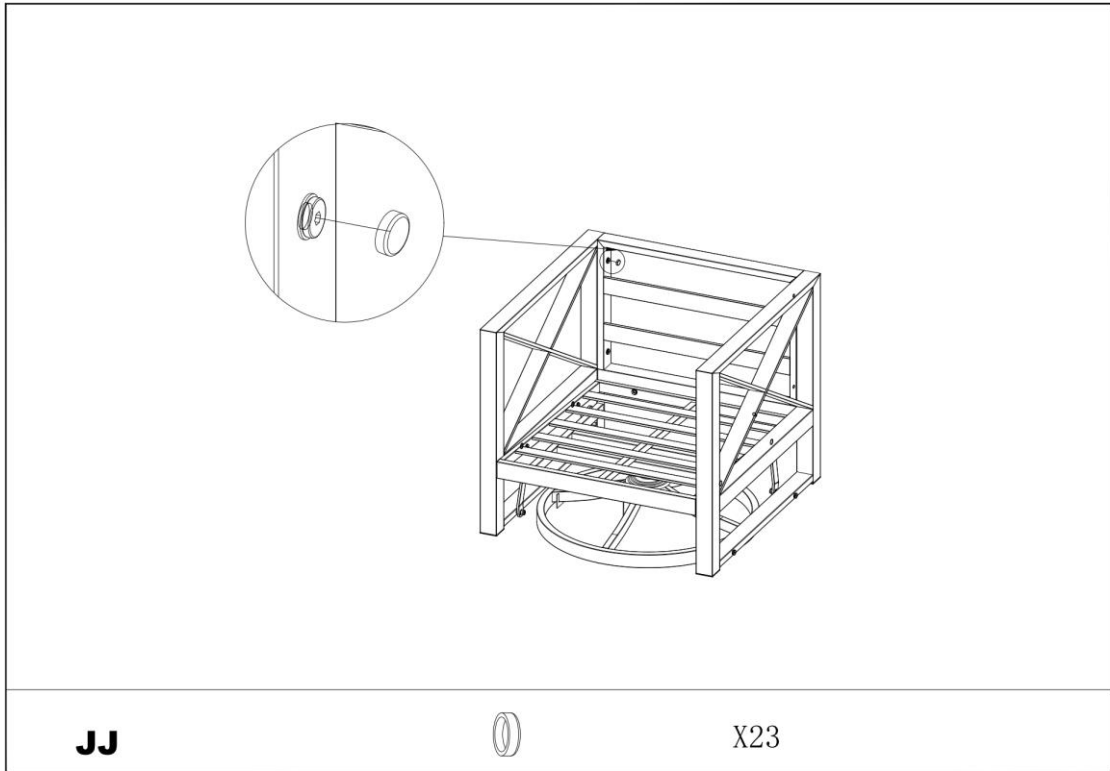

**STEP 8: Put the nut caps on the nuts.**

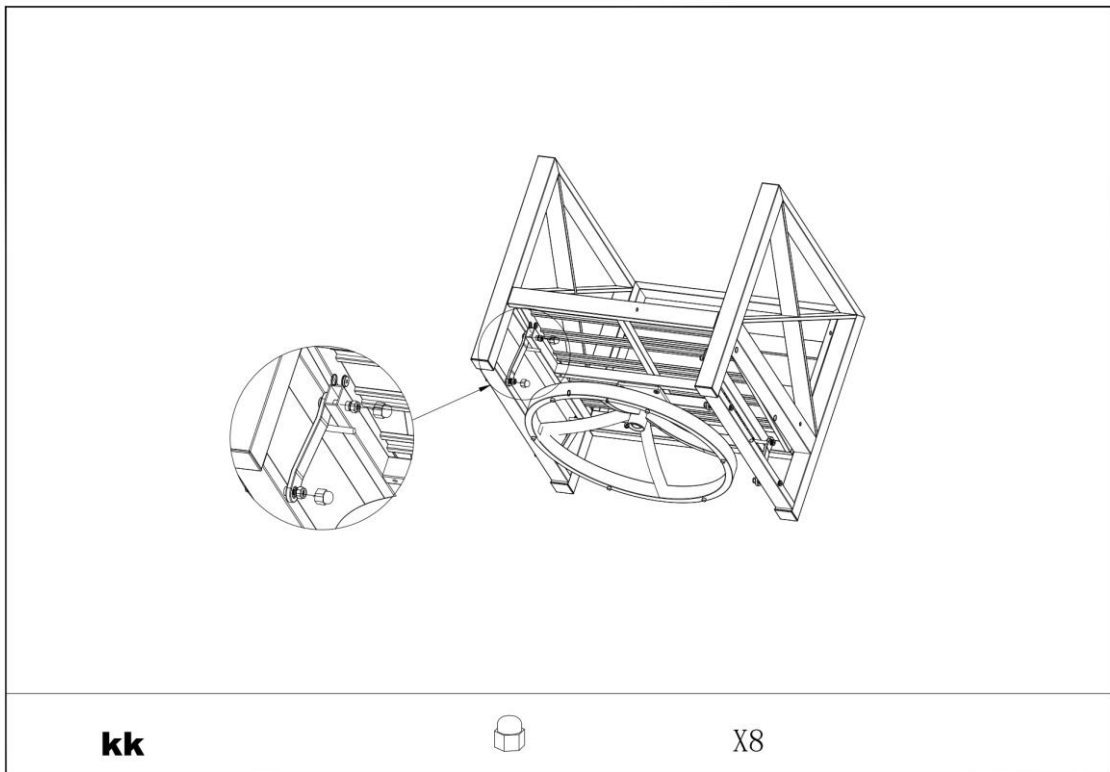

**STEP 9: Place the seat cushion(I)**

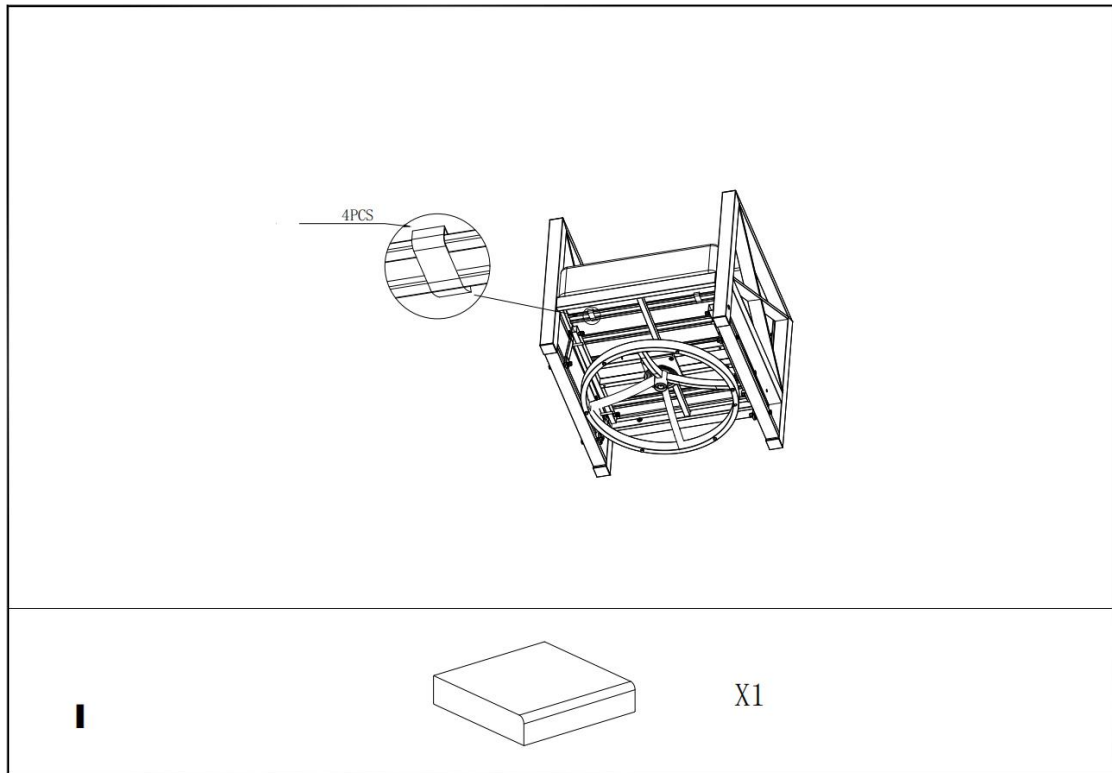

**STEP 10: Place the back cushion(H).**

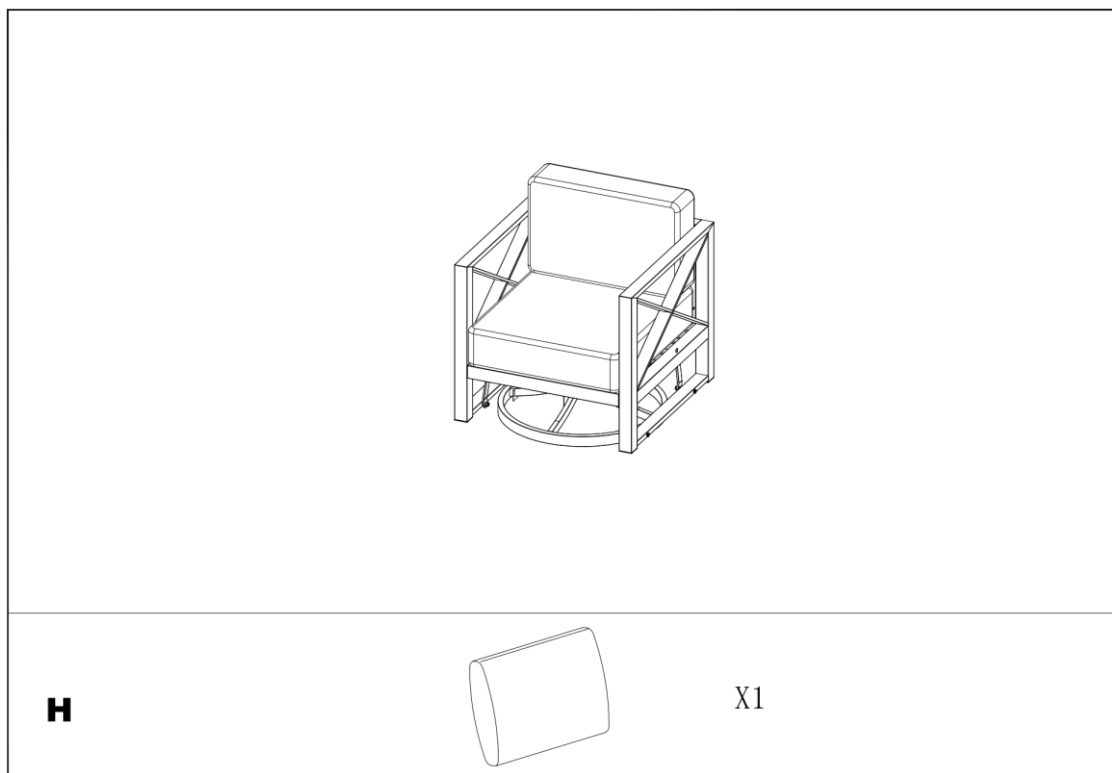

**\*\* Assembly is complete, the sofa is ready for use.**

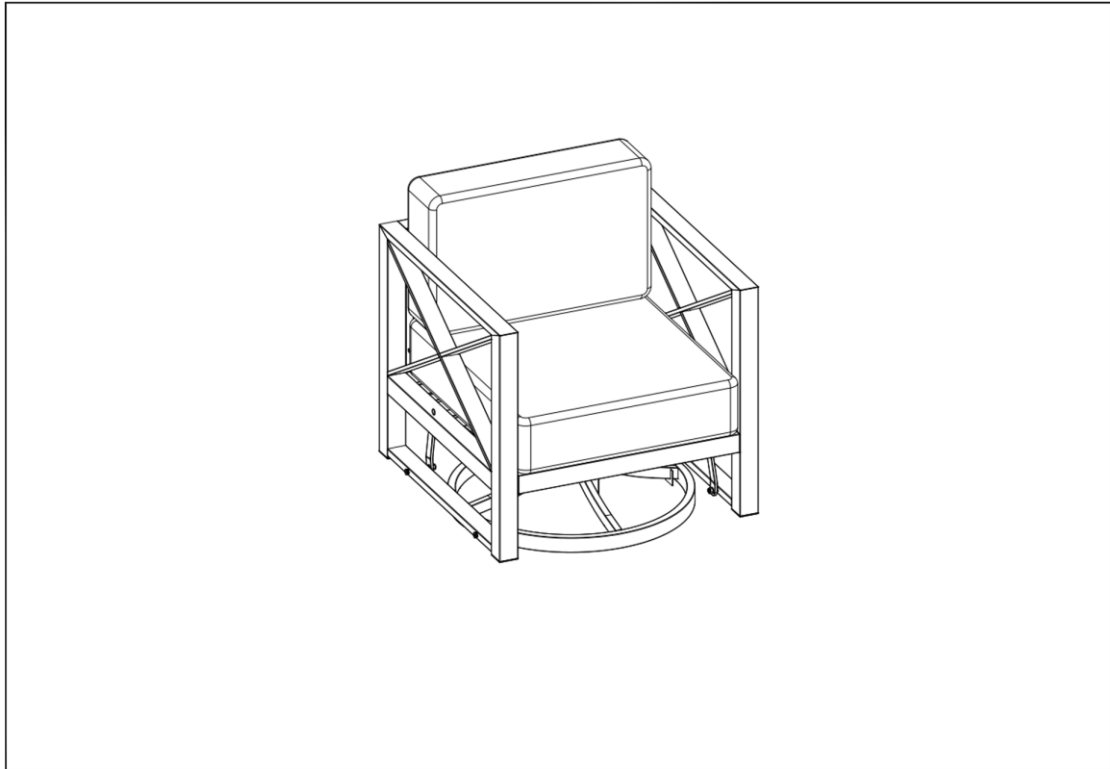

## **CLEANING&MAINTENANCE**

### **FRAME**

**Cleaning** - Use mild soap and warm water. Do not use abrasive materials, cleaners, or bleach products. Rinse with clean water and dry thoroughly.

**Maintenance** -Periodically clean and dry thoroughly. Be sure to drain any water accumulated inside the frames. To thoroughly drain frames, remove foot caps and tilt the frames, if necessary, to remove all water. This is critical. Water allowed to accumulate inside the frames and then exposed to sub-freezing temperatures can cause damage to the frame tubing. Such damage is not covered under warranty. Always clean, drain, and dry thoroughly before storing for the winter. For best results, always store or cover your furniture when not in use.

**\*\* When cleaning or moving large or heavy items, always have two people work together. Never drag furniture.**

## **FABRIC (CUSHIONS)**

**Cleaning** - Fabric should be cleaned regularly. Brush off any loose dirt and wash with a mild soap and lukewarm water

solution. For stubborn stains and mildew, wash with a solution of 236.6 ml / 1 cup of bleach and 59.2 ml / 0.25 cup of mild soap per 3.79L / 1 gallon of water. Rinse thoroughly to remove soap. Allow fabric to air dry.

**Maintenance** - The best way to maintain the beauty of cushions and slings is to store them in a dry area and out of the elements when not in use, or cover with commercially available outdoor furniture covers.

## **CUSHIONS**

To ensure longevity of your patio set each seat cushion is made with high density foam. With initial use the seat cushions may feel firm, but with continued use the cushions will continue to soften and provide the ultimate comfort for seasons to come.

Cushions can become water saturated with heavy water exposure. To allow cushions to air-dry properly, follow the suggested steps:

- \* Unzip cushion cover to ventilate and facilitate the drying process. Do not remove cushion covers.
- \* Place cushions upright for faster drainage. Ventilation zipper should be facing down.
- \* Store cushions indoors during rainy seasons and inclement weather.

# Montage- und Pflegeanweisungen

## SCHWENKSTUHL

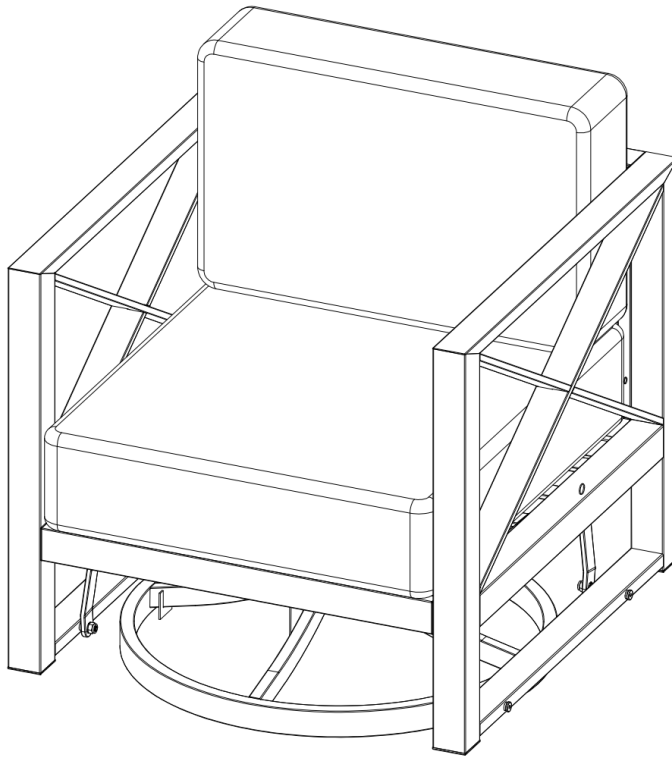

### WICHTIG

#### **BITTE LESEN, BEVOR SIE MIT DER MONTAGE BEGINNEN**

---

Befolgen Sie die Richtlinien in dieser Bedienungsanleitung, um eine korrekte Montage und Pflege dieses Produkts sicherzustellen

## **LESEN SIE VOR DER VERWENDUNG ALLE**

### **ANWEISUNGEN**

Befolgen Sie bei der Verwendung dieser Einrichtungsgegenstände stets die grundlegenden Vorsichtsmaßnahmen, einschließlich der folgenden:

Lesen Sie alle Anweisungen, bevor Sie dieses Set verwenden.

Um das Verletzungsrisiko für Personen zu verringern:

- Verwenden Sie dieses Set nicht auf weichem Untergrund.
- Stellen Sie sich nicht auf die montierten Stühle, das Sofa, die Ottomane oder die Feuerstelle und lassen Sie keine Kinder darauf stehen.
- Überprüfen Sie nach der Montage, ob alle Hardwareverbindungen sicher sind, bevor Sie das Produkt in Betrieb nehmen.
- Unsachgemäße Installation, Einstellung, Änderung, Service oder Wartung können zu Verletzungen oder Sachschäden führen.
- Lesen Sie alle Installations-, Betriebs- und Wartungsanweisungen sorgfältig durch, bevor Sie dieses Gerät installieren oder warten.

### **MONTAGEPLANUNG**

Bevor Sie mit der Montage beginnen, entleeren Sie den Karton vollständig und entfernen Sie sämtliches Verpackungsmaterial. Stellen Sie sicher, dass alle Teile und Hardware vorhanden sind. Falls Teile fehlen oder Fragen zu Beschädigungen bestehen, kontaktieren Sie uns bitte rechtzeitig, unser After-Sales-Team wird Ihnen innerhalb von 24 Stunden antworten.

Bitte machen Sie Fotos von der SKU-Nummer und dem WA-Etikett, bevor Sie die Kartons öffnen. Wenn Sie feststellen, dass etwas nicht stimmt, senden Sie uns bitte die Details zusammen mit den oben genannten Fotos. Dies hilft uns, das Problem schneller zu lösen.







## INHALTSANGABEN DER VERPACKUNG - 1



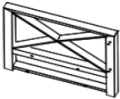

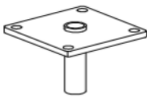

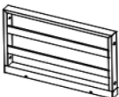

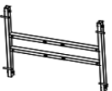



### SCHWENKSTUHL

**HINWEIS:** Legen Sie alle Teile auf eine weiche, nicht abrasive, ebene Fläche zum Zusammenbauen. Ziehen Sie die Verbindungsteile nicht zu fest an.

## SCHRITTE ZUR MONTAGE DES SCHWENKSTUHL

### TEILLISTE DES SCHWENKSTUHL

Part	Description	Qty(pcs)	Part	Description	Qty(pcs)
A		1	F		1
B		1	G		1
C		1	H		1
D		1	I		1
E		1			

Part	Description	Qty(pcs)	Part	Description	Qty(pcs)	Part	Description	Qty(pcs)
AA	 M6*35	11	FF	 M8	4	KK	 M8	8
BB	 M8*25	4	GG	 M6	1	LL		1
CC	 M8*80	4	HH	 M8	12	MM		1
DD	 M6	10	II	 M6 $\varnothing 29$	1			
EE	 M8	4	JJ	 M6/M8	23			

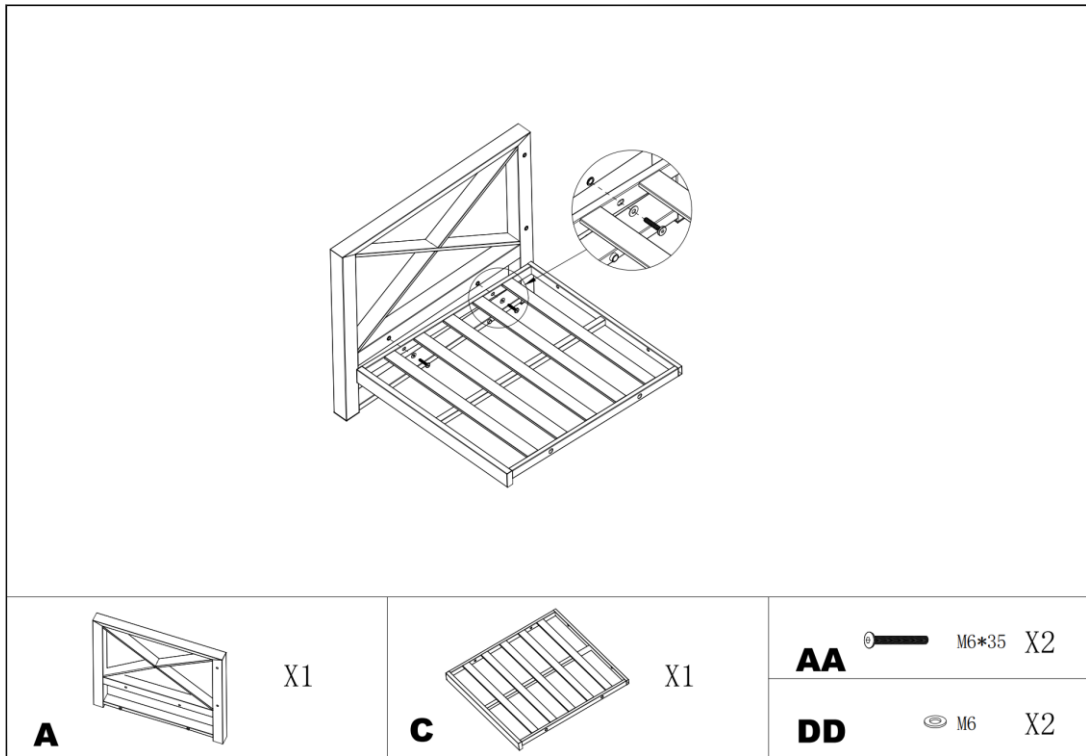
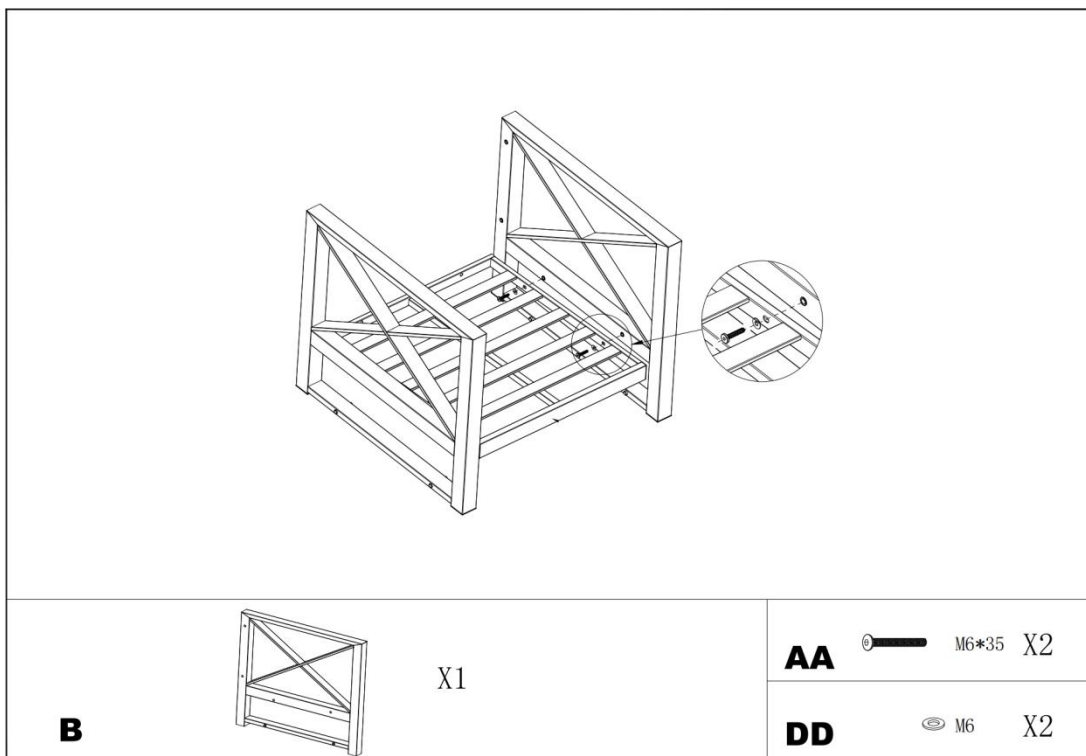
**SCHRITT 1: Verbinden Sie die rechte Armlehne (A) mit der Sitzplatte (C).****SCHRITT 2: Verbinden Sie die linke Armlehne (B) mit der Sitzplatte.**

### SCHRITT 3: Befestigen Sie die Rückenlehne (D) an der Bodenplatte und den Armlehnen.

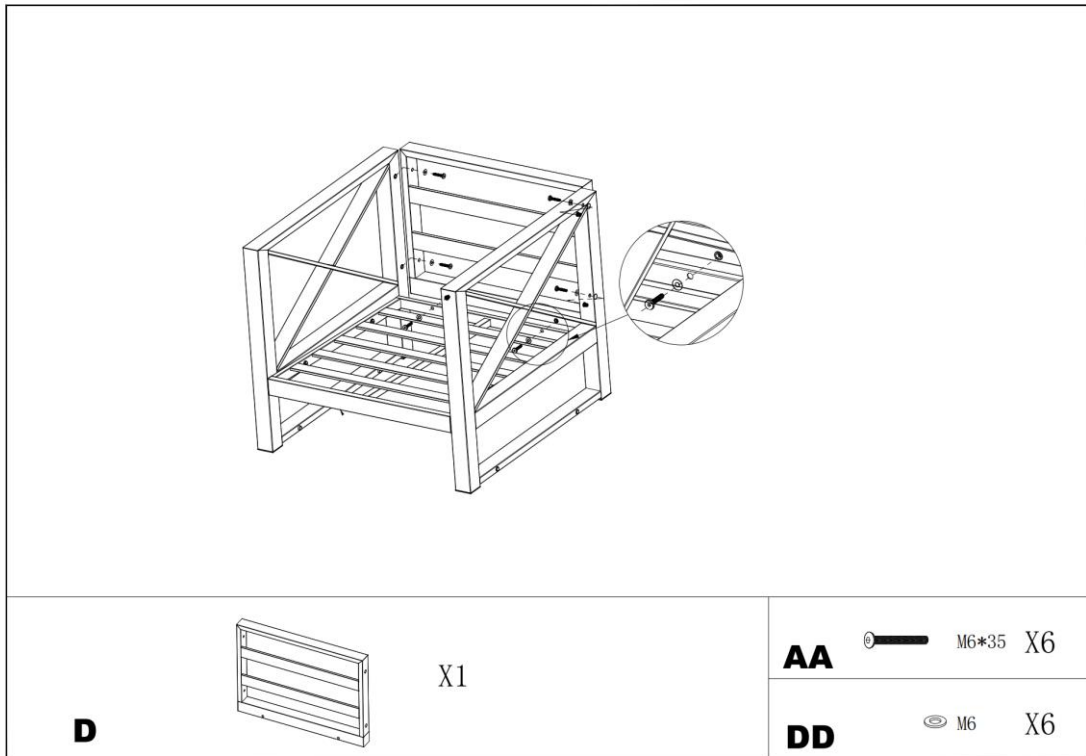

### SCHRITT 4: Verbinden Sie die H - Form - Halterung (E) mit der Welle (G).

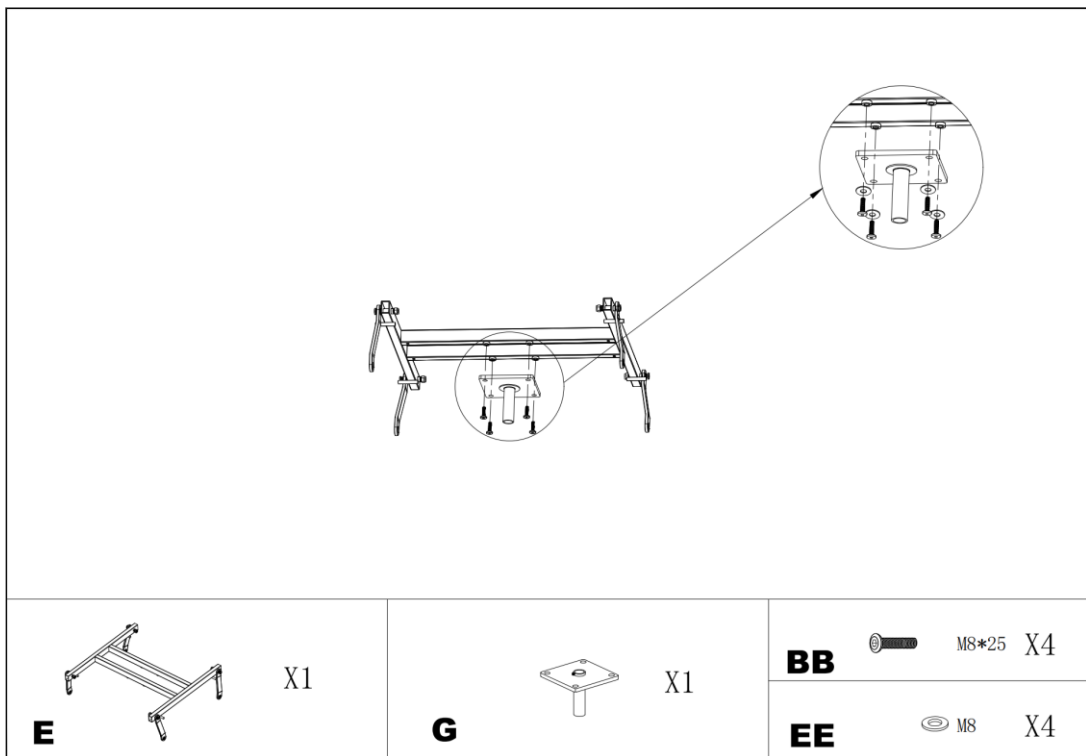

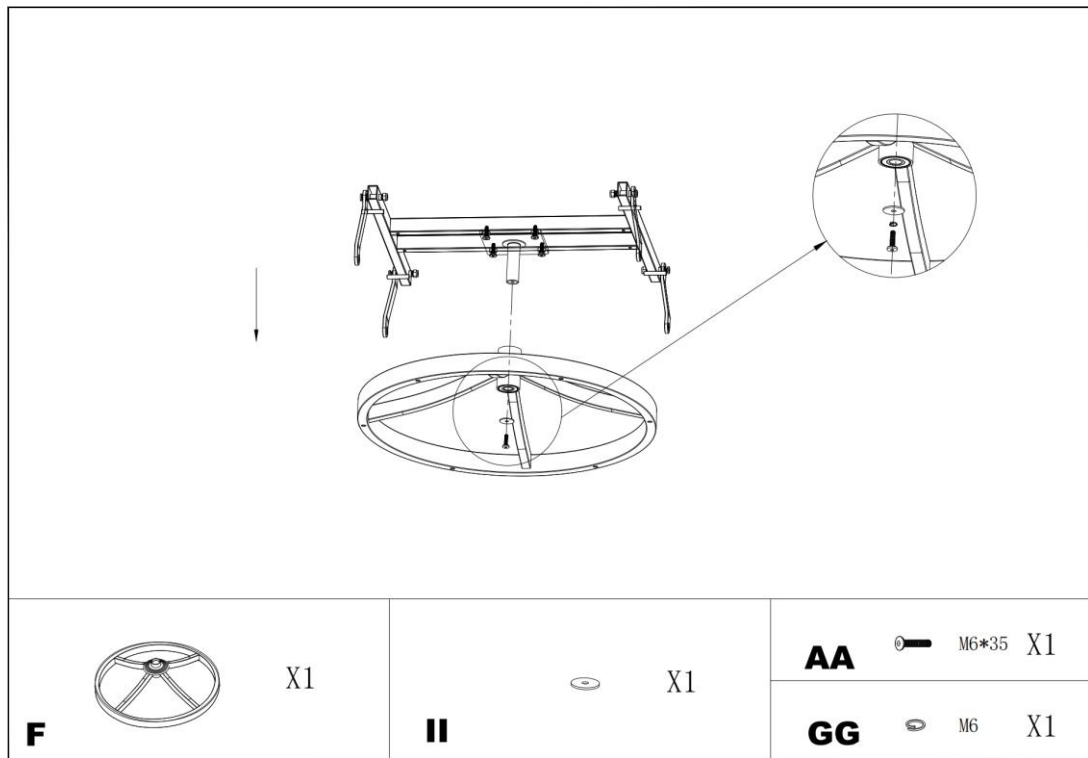
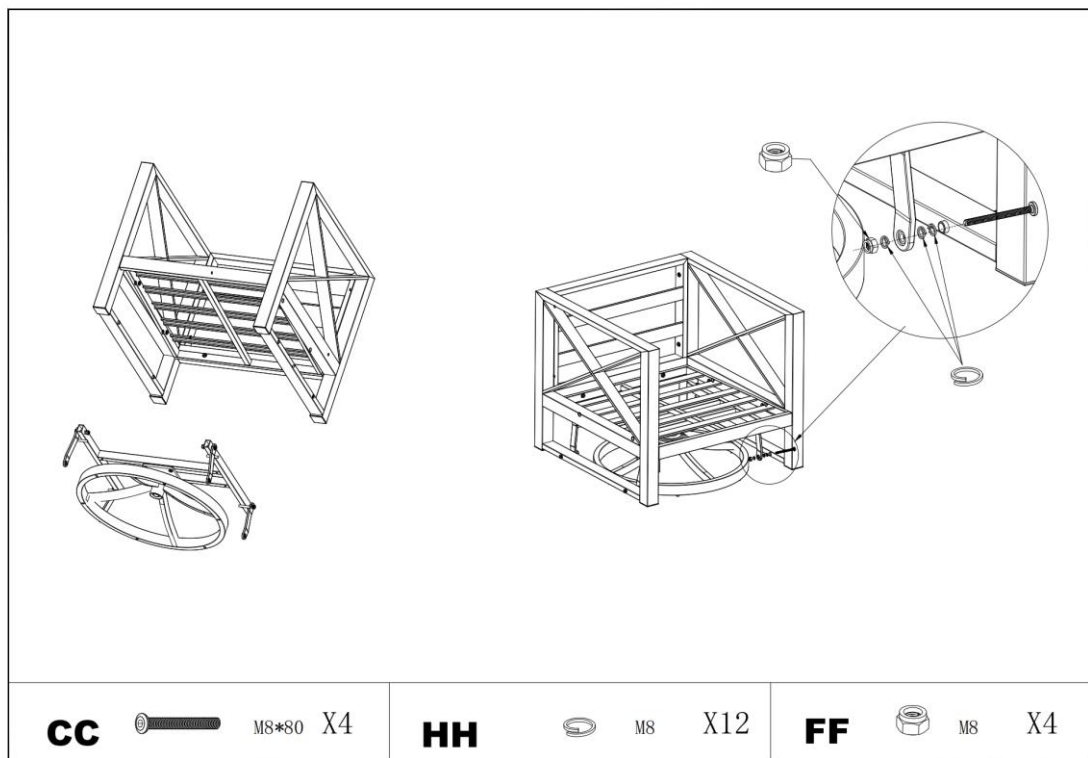
**SCHRITT 5: Verbinden Sie die Welle (G) mit der Sesselbasis (F).****SCHRITT 6: Verbinden Sie die Stuhlbasis mit dem Sessel.**

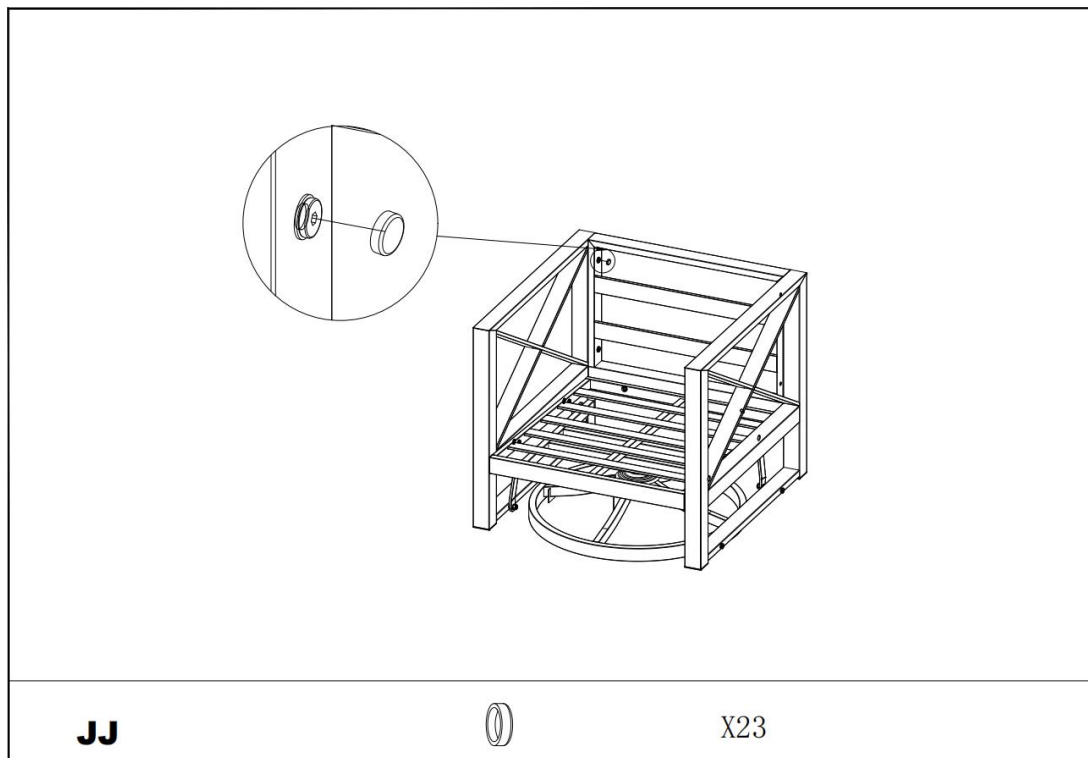
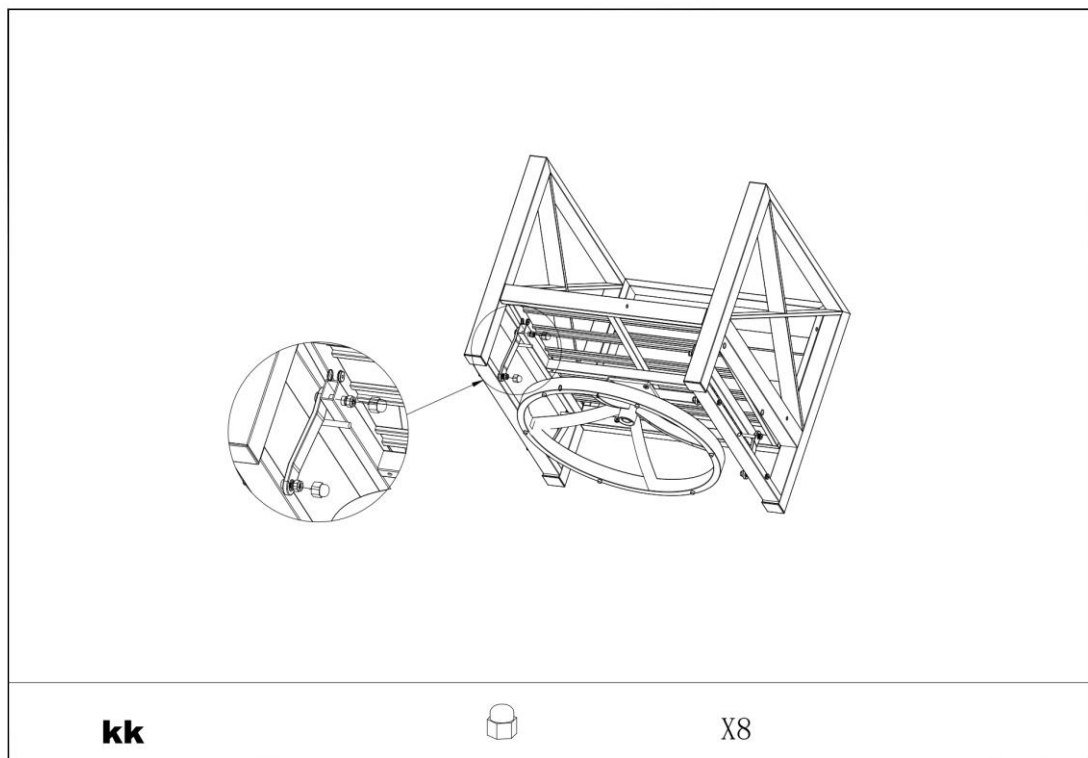
**SCHRITT 7: Setzen Sie die Schraubkappen auf die Schrauben.****SCHRITT 8: Setzen Sie die Mutterkappen auf die Muttern.**

**SCHRITT 9: Legen Sie die Sitzpolsterung (I) auf.**

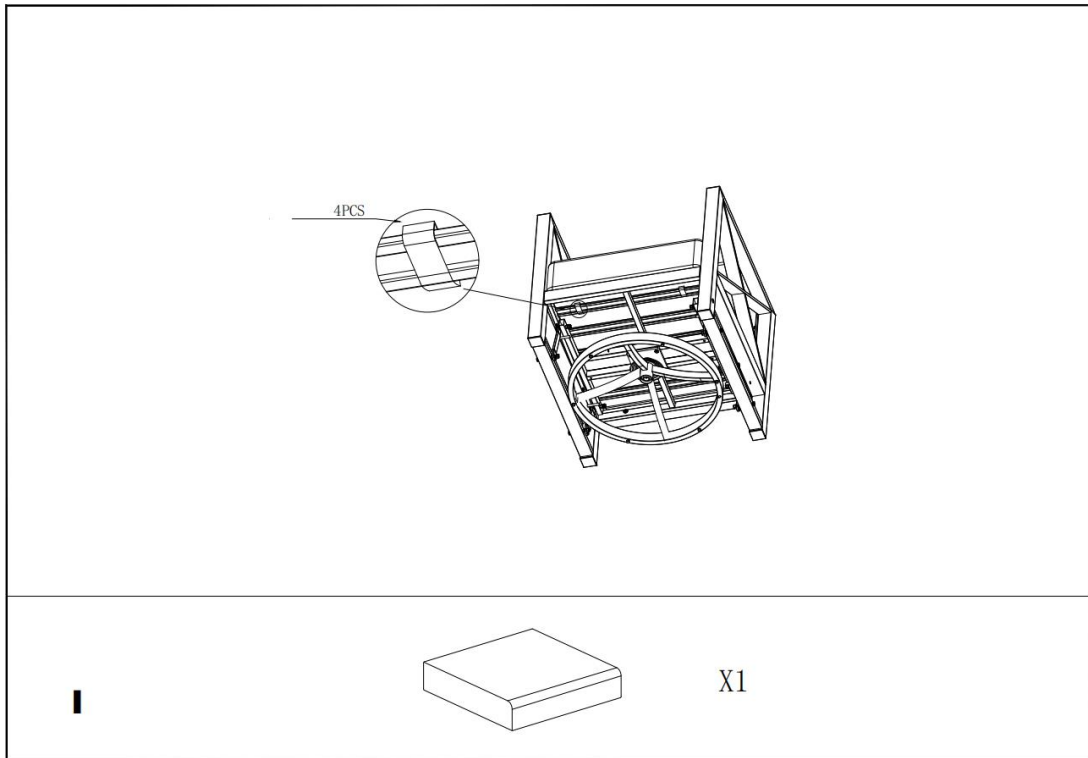

**SCHRITT 10: Legen Sie das Rückenpolster (H) auf.**

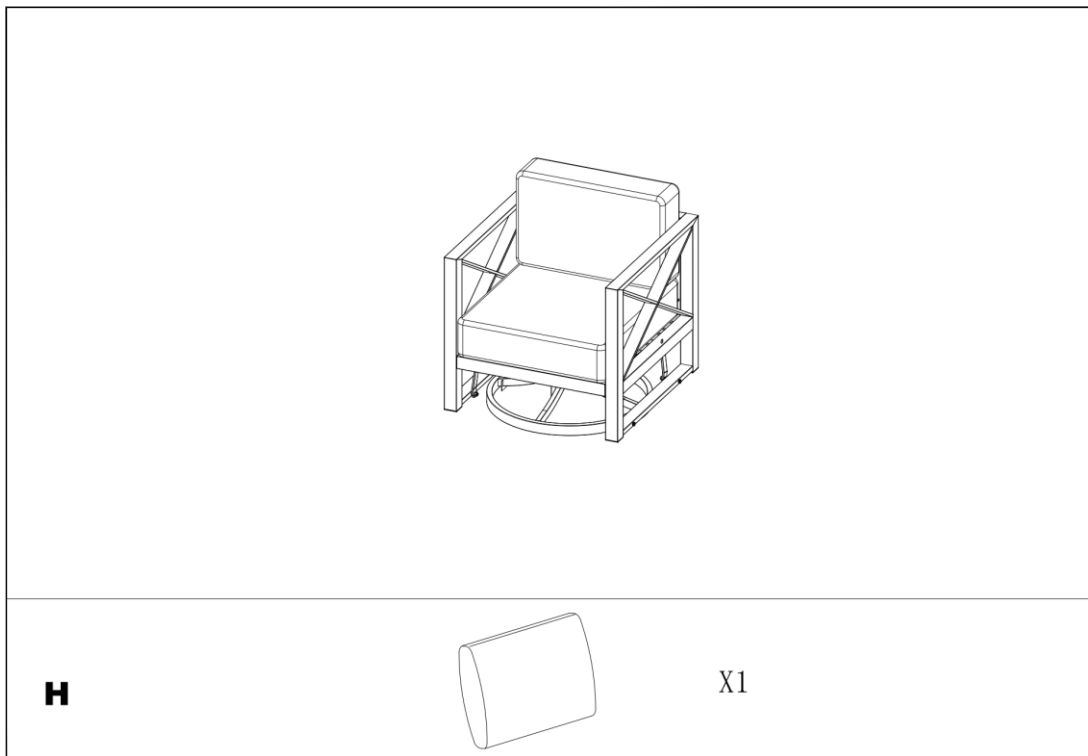

**\*\*Die Montage ist abgeschlossen, der Sessel ist einsatzbereit.**

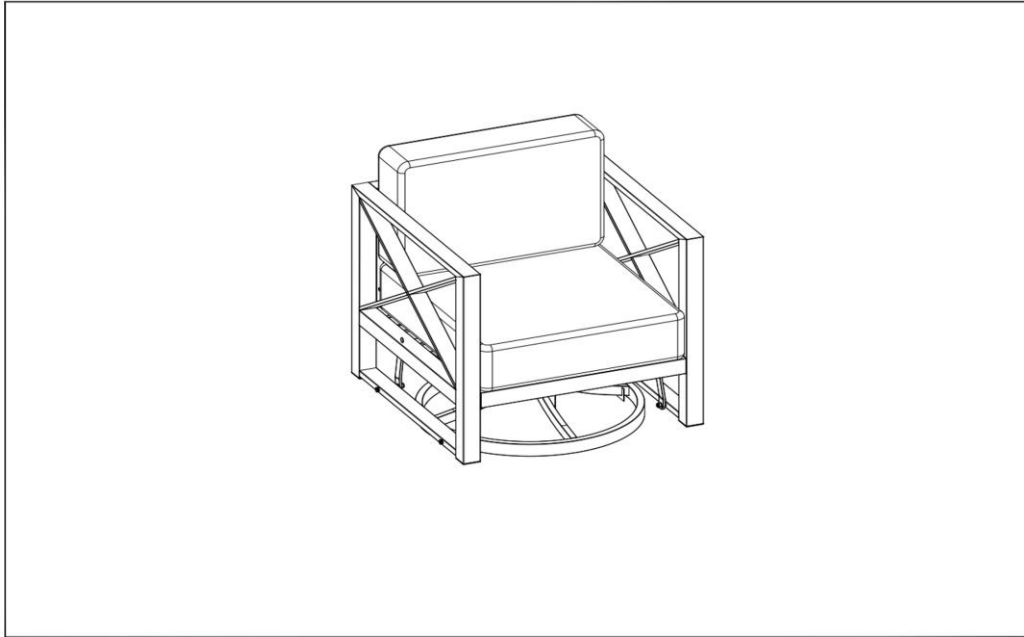

## **REINIGUNG WARTUNG**

### **RAHMEN**

**Reinigung** - Verwenden Sie mildes Seifenwasser und warmes Wasser. Verwenden Sie keine abrasiven Materialien, Reinigungsmittel oder Bleichprodukte. Spülen Sie mit sauberem Wasser ab und trocknen Sie gründlich ab.

**Wartung** - Reinigen und trocknen Sie regelmäßig und gründlich. Stellen Sie sicher, dass Wasser, das sich im Inneren des Rahmens angesammelt hat, abgelassen wird. Um den Rahmen gründlich zu entleeren, entfernen Sie die Fußkappen und kippen Sie die Rahmen, falls nötig, um das Wasser zu entfernen. Dies ist entscheidend. Wenn Wasser im Rahmen verbleibt und dann extrem niedrigen Temperaturen ausgesetzt wird, kann dies die Rahmenrohre beschädigen. Solche Schäden sind nicht durch die Garantie abgedeckt. Reinigen, entleeren und trocknen Sie die Möbel gründlich, bevor Sie sie im Winter lagern. Für die besten Ergebnisse sollten Sie Ihre Möbel immer lagern oder abdecken, wenn sie nicht in Gebrauch sind.

**Beim Reinigen oder Bewegen großer oder schwerer Gegenstände sollten immer zwei Personen zusammenarbeiten. Ziehen Sie Möbel niemals über**

**den Boden.**

### **STOFF**

**Reinigung** - Der Stoff sollte regelmäßig gereinigt werden. Bürsten Sie losen Schmutz ab und waschen Sie ihn mit einer milden Seifen- und lauwarmen Wasserlösung. Für hartnäckige Flecken und Schimmel waschen Sie mit einer Lösung aus 236,6 ml / 1 Tasse Bleichmittel und 59,2 ml / 0,25 Tasse milder Seife pro 3,79L / 1 Gallone Wasser. Spülen Sie gründlich, um Seife zu entfernen. Lassen Sie den Stoff an der Luft trocknen.

**Wartung** - Die beste Möglichkeit, die Schönheit der Kissen und Schlingen zu erhalten, besteht darin, sie in einem trockenen Bereich und außerhalb der Witterung zu lagern, wenn sie nicht in Gebrauch sind, oder sie mit handelsüblichen Möbelabdeckungen für den Außenbereich zu bedecken.

### **COUSSIN**

Um die Langlebigkeit Ihres Terrassensets zu gewährleisten, ist jedes Sitzkissen mit hochdichtem Schaumstoff gefertigt. Bei der ersten Verwendung können die Sitzkissen fest erscheinen, aber mit der fortlaufenden Nutzung werden die Kissen weicher und bieten ultimativen Komfort für die kommenden Saisonen.

Kissen können bei starker Wasserbelastung mit Wasser gesättigt werden. Um den Kissen eine ordnungsgemäße Trocknung zu ermöglichen, befolgen Sie bitte die folgenden Schritte:

- \* Öffnen Sie den Reißverschluss des Kissenschoners, um die Belüftung zu fördern und den Trocknungsprozess zu beschleunigen. Entfernen Sie die Kissenbezüge nicht.
- \* Stellen Sie die Kissen aufrecht hin, um eine schnellere Entwässerung zu ermöglichen. Der Belüftungsreißverschluss sollte nach unten zeigen.
- \* Lagern Sie die Kissen während der Regenzeit und bei schlechtem Wetter drinnen.

# Instructions de montage et d'entretien

## FAUTEUIL PIVOTANT

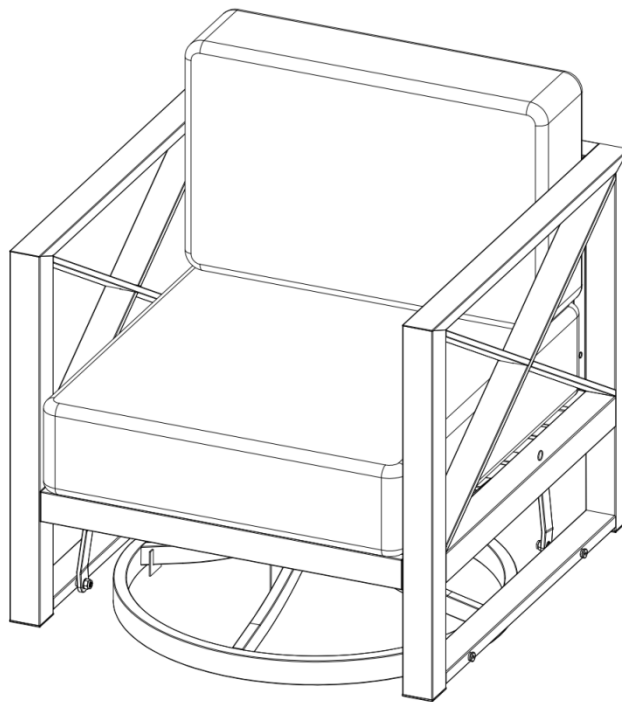

### **IMPORTANT**

#### **VEUILLEZ LIRE CECI AVANT DE COMMENCER L'ASSEMBLAGE**

---

Suivez les instructions de ce guide utilisateur pour assurer un assemblage correct et un entretien de ce produit.

## **LIRE TOUTES LES INSTRUCTIONS AVANT UTILISATION**

Lorsque vous utilisez ces meubles, suivez toujours les précautions de base, notamment les suivantes :

Lisez toutes les instructions avant d'utiliser cet ensemble.

Pour réduire le risque de blessures corporelles :

N'utilisez pas cet ensemble sur un sol mou.

- Ne vous tenez pas debout et ne laissez pas les enfants se tenir debout sur les chaises, le canapé, le pouf ou le foyer assemblés.
- Après l'assemblage, vérifiez que toutes les connexions matérielles sont sécurisées avant de mettre le produit en service.
- Une installation, un réglage, une modification, un service ou un entretien inappropriés peuvent provoquer des blessures ou des dommages matériels.
- Lisez attentivement toutes les instructions d'installation, de fonctionnement et d'entretien avant d'installer ou d'entretenir cet équipement.

## **ASSEMBLÉE DE PLANIFICATION**

Avant de commencer l'assemblage, videz complètement le contenu du carton et retirez tout le matériel d'emballage. Assurez-vous que toutes les pièces et le matériel sont présent. Si des pièces sont manquantes ou si vous avez des questions concernant les dommages, veuillez nous contacter à temps, notre équipe après-vente vous répondra dans les 24 heures.







Veuillez prendre des photos du numéro SKU et de l'étiquette WA avant d'ouvrir les boîtes. Si vous constatez un problème, veuillez nous envoyer les détails avec les photos ci-dessus. Cela nous aidera à résoudre le problème plus rapidement.



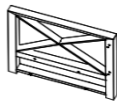

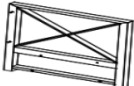
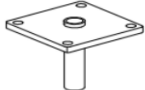

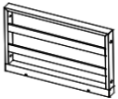
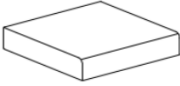





## CONTENU DU PAQUET - 1 FAUTEUIL PIVOTANT

**REMARQUE:** Placez toutes les pièces sur une surface douce, nonabrasive et nivelée pour l'assemblage. Ne serrez pas trop fort les connexions matérielles.

## LES ÉTAPES D'INSTALLATION DU FAUTEUIL PIVOTANT

### LISTE DES PIÈCES

Partie	Description	Qty(pcs)	Partie	Description	Qty(pcs)
A		1	F		1
B		1	G		1
C		1	H		1
D		1	I		1
E		1			

Partie	Description	Qty(pcs)	Partie	Description	Qty(pcs)	Partie	Description	Qty(pcs)
AA	 M6*35	11	FF	 M8	4	KK	 M8	8
BB	 M8*25	4	GG	 M6	1	LL		1
CC	 M8*80	4	HH	 M8	12	MM		1
DD	 M6	10	II	 M6 Ø29	1			
EE	 M8	4	JJ	 M6/M8	23			

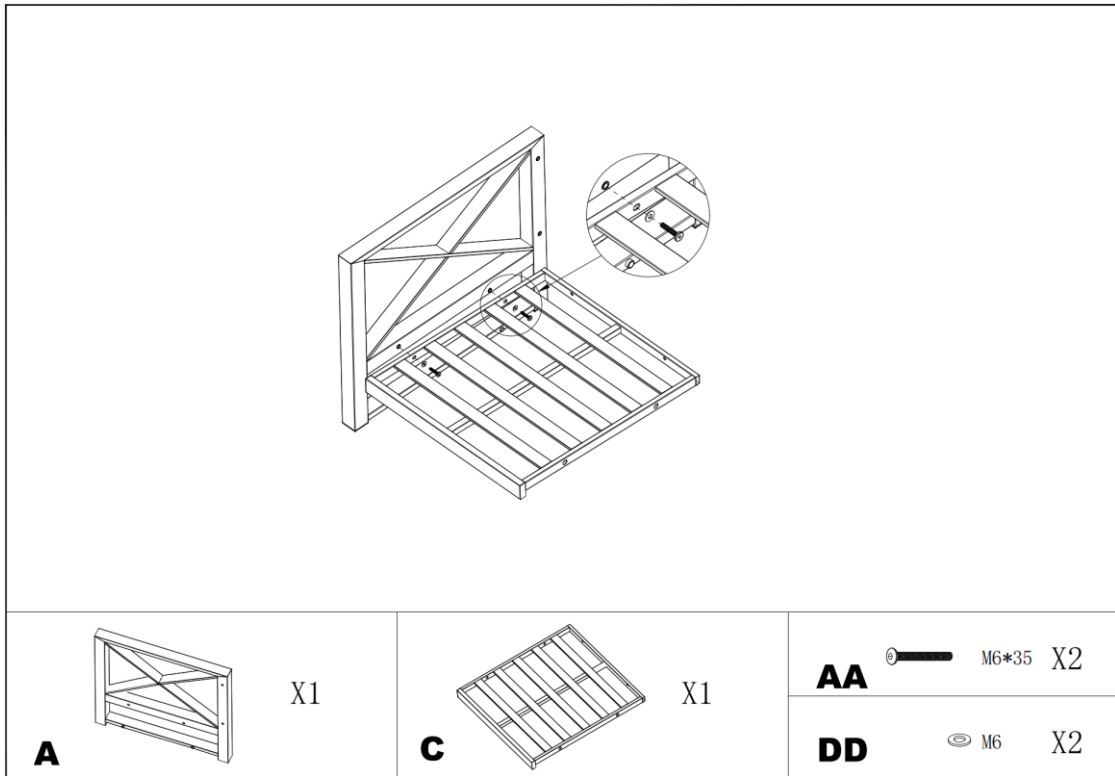
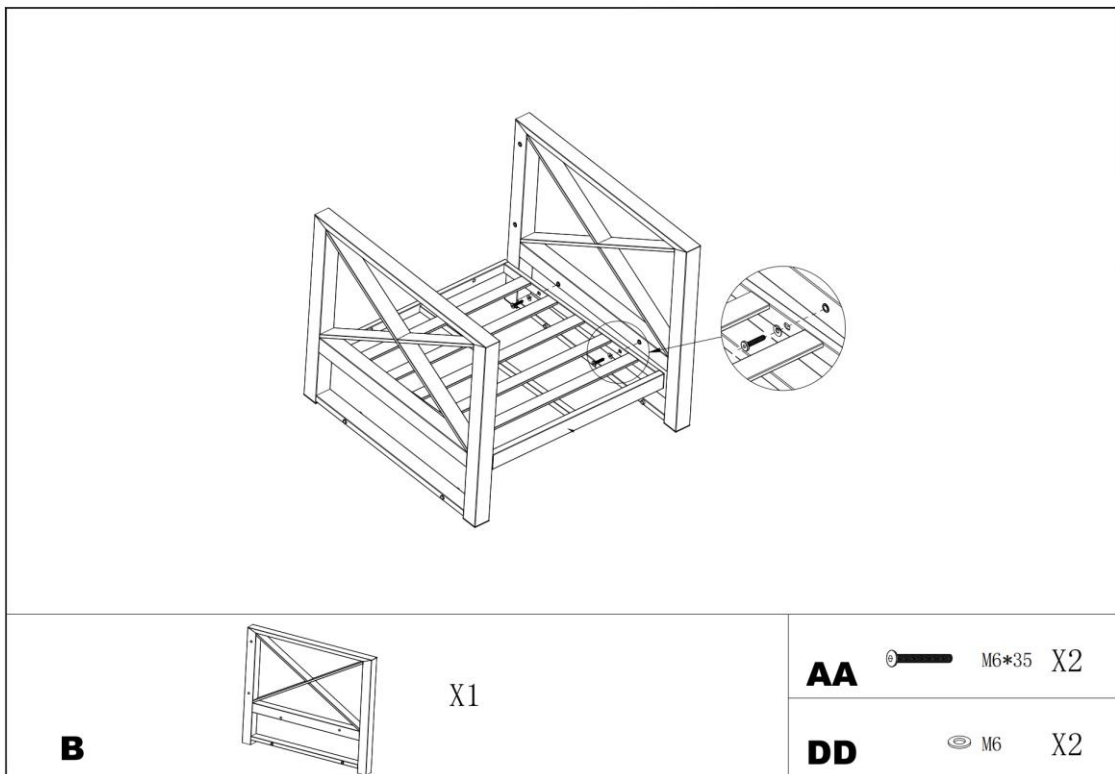
**ÉTAPE 1: Connectez le repos-bras droit (A) à la plaque de siège (C).****ÉTAPE 2: Connectez le repos-bras gauche (B) à la plaque de siège.**

### ÉTAPE 3: Fixez le dossier (D) à la plaque de base et aux repos-bras.

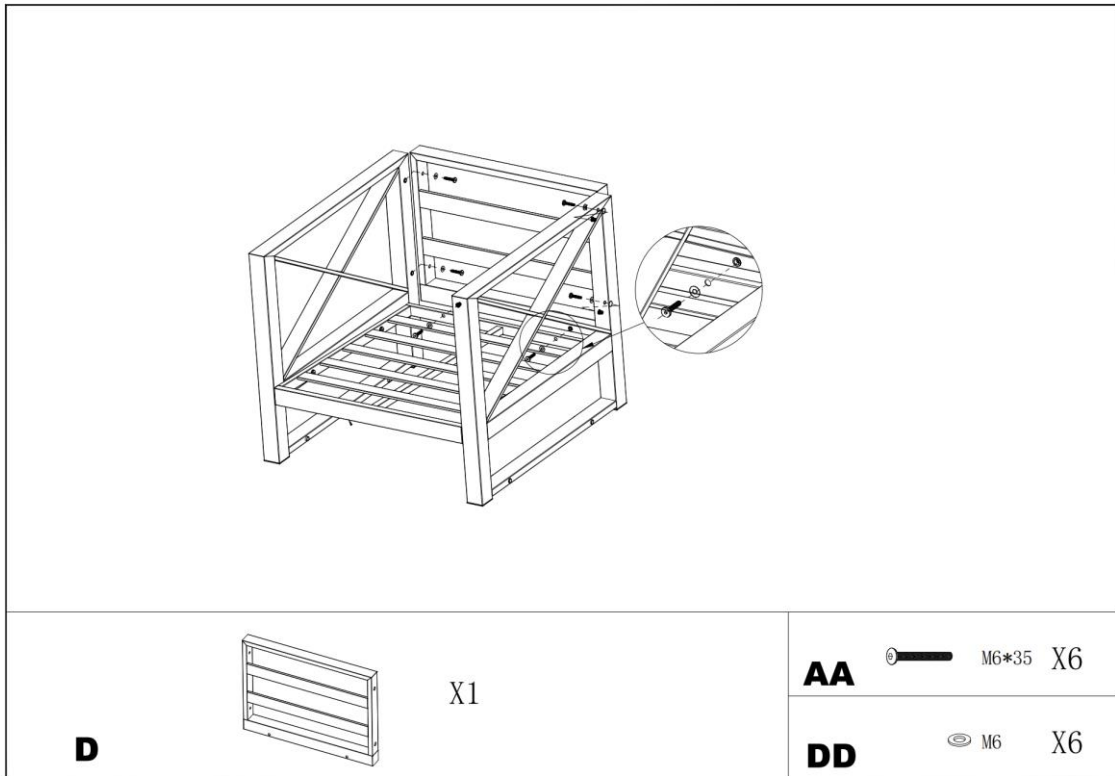

### ÉTAPE 4: Connectez le support en H (E) et l'arbre (G).

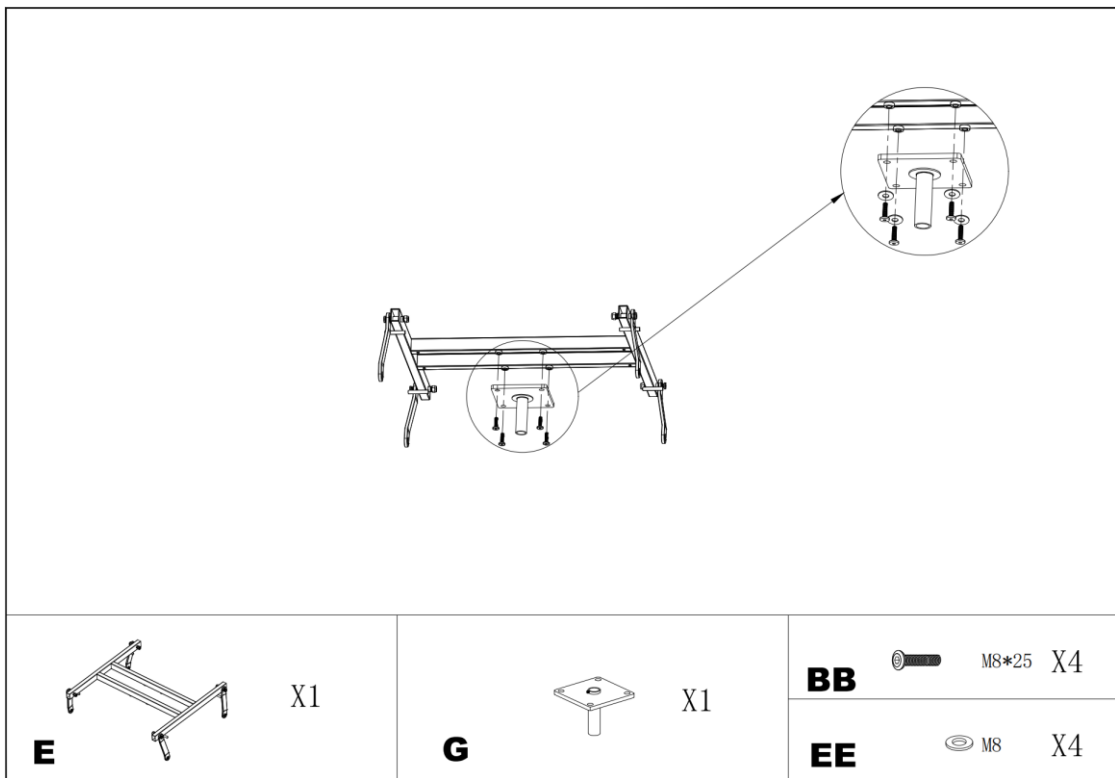

## ÉTAPE 5: Reliez l'arbre (G) à la base de la chaise (F).

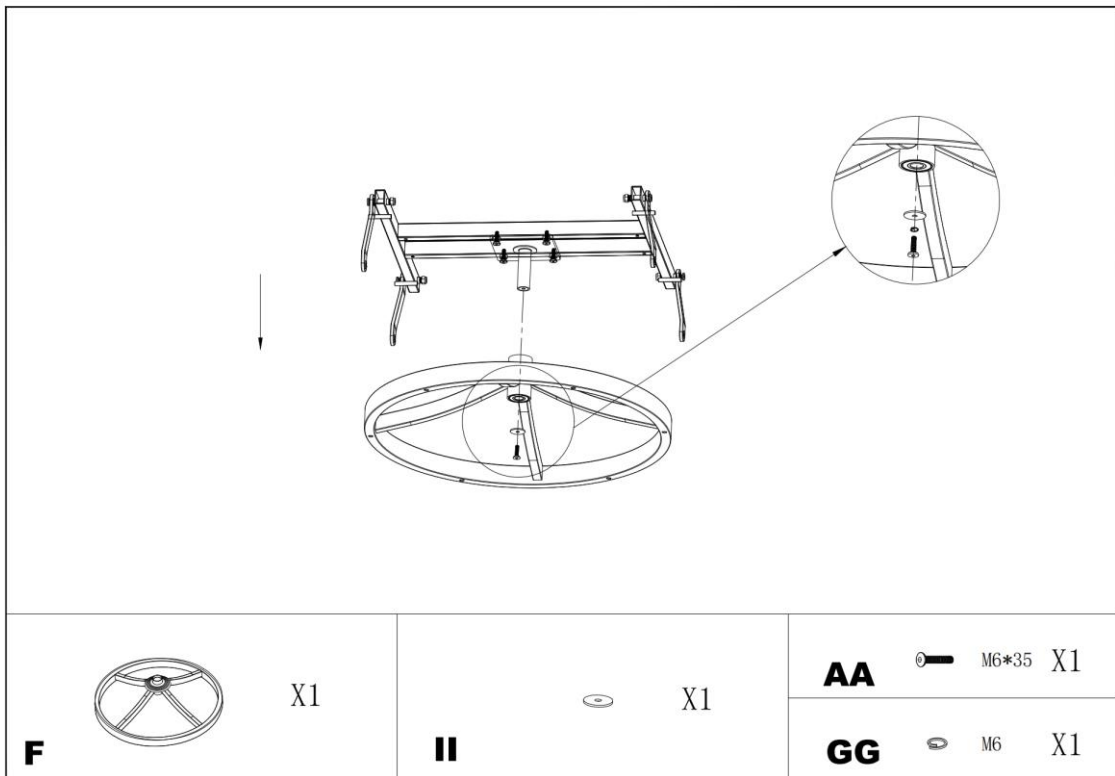

## ÉTAPE 6: Connectez la base du fauteuil et le fauteuil.

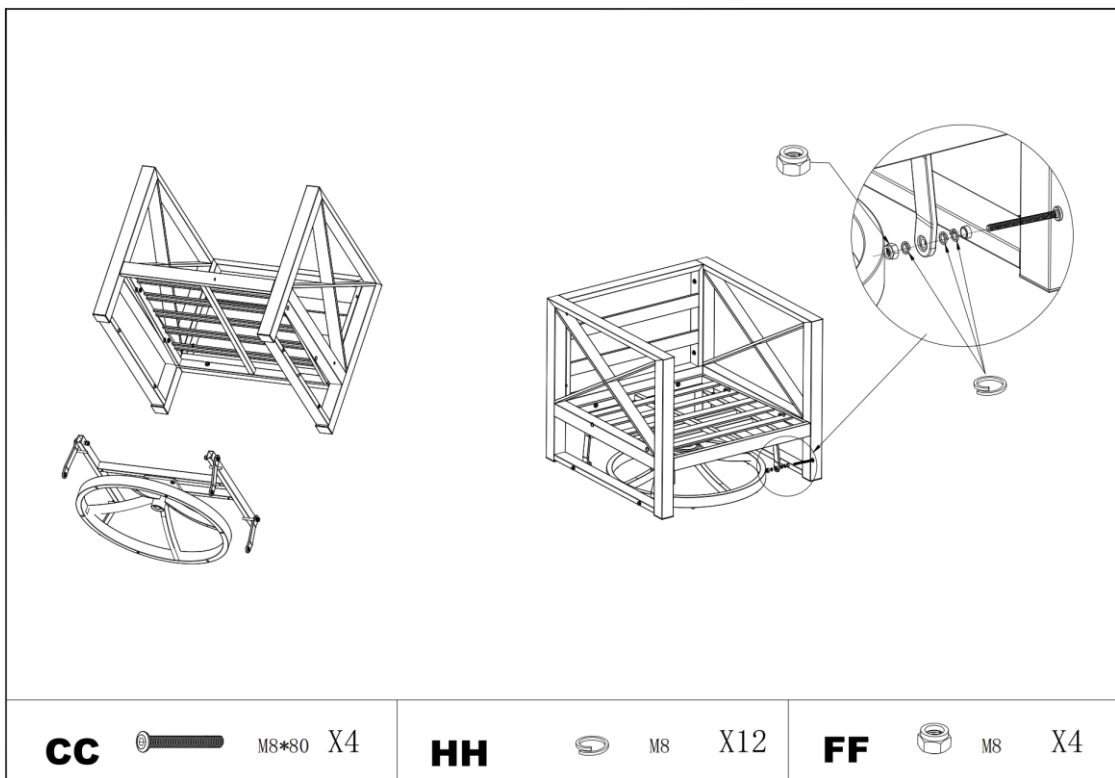

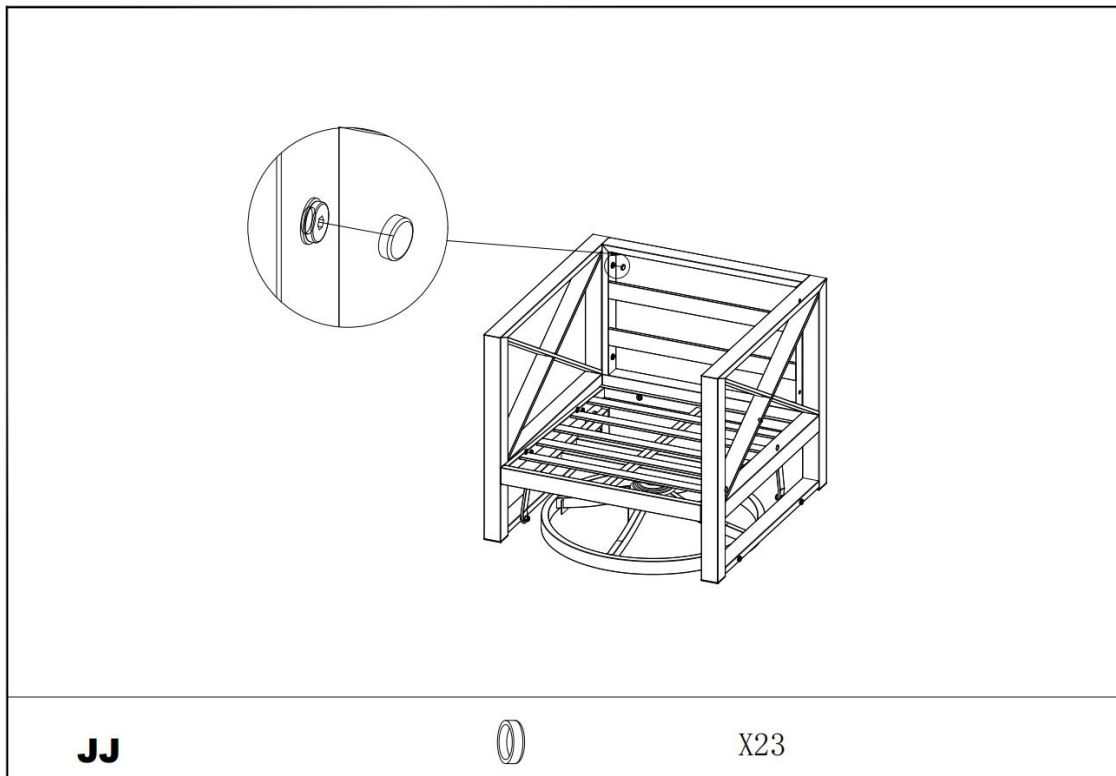
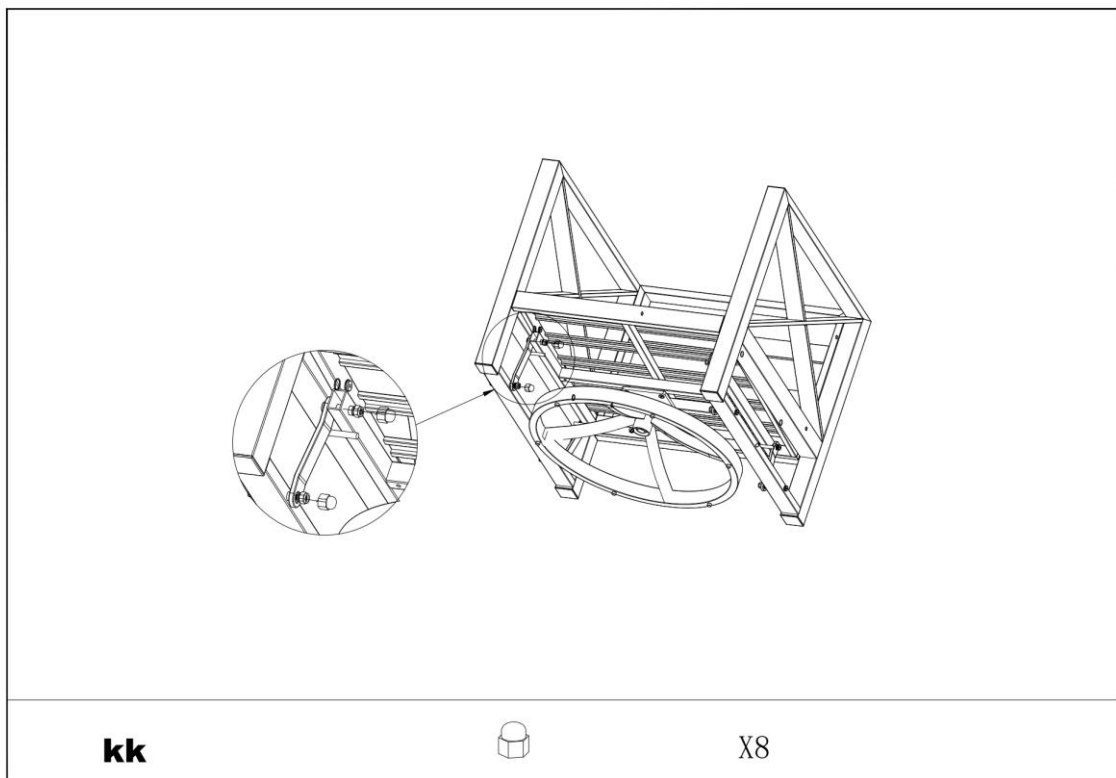
**ÉTAPE 7: Placez les bouchons de vis sur les vis.****ÉTAPE 8: Placez les bouchons d'écrous sur les écrous.**

**ÉTAPE 9: Placez le coussin de siège (I).**

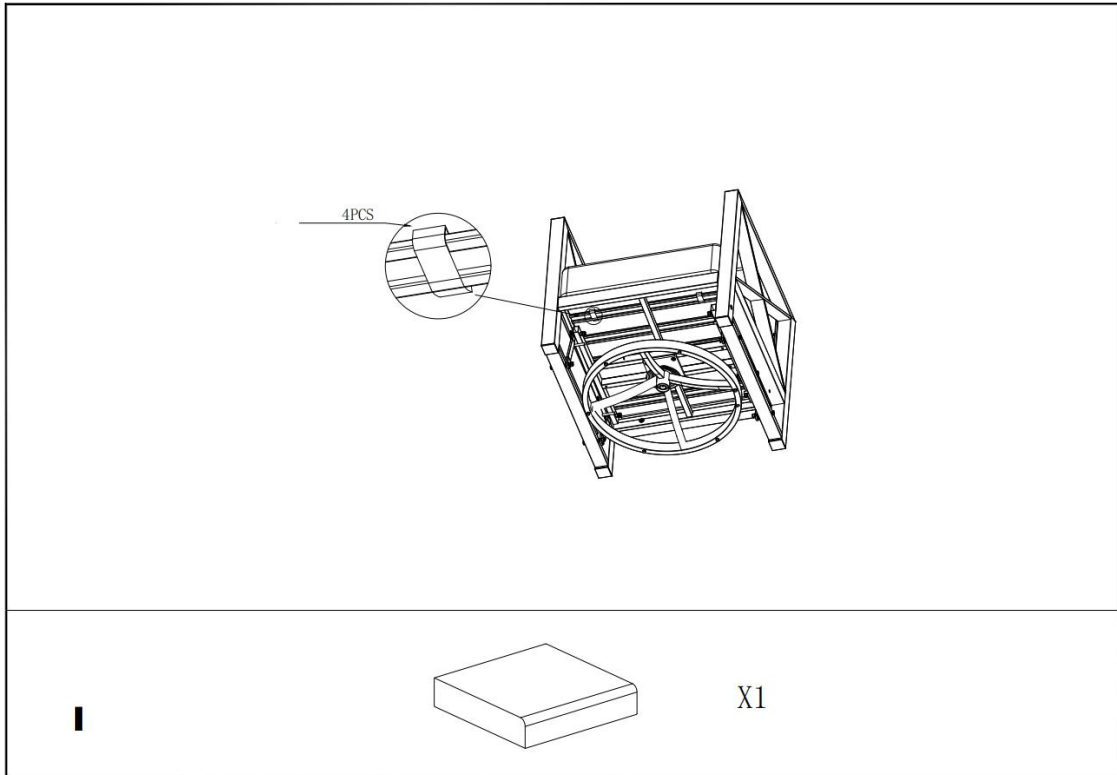

**ÉTAPE 10: Placez le coussin de dos (H).**

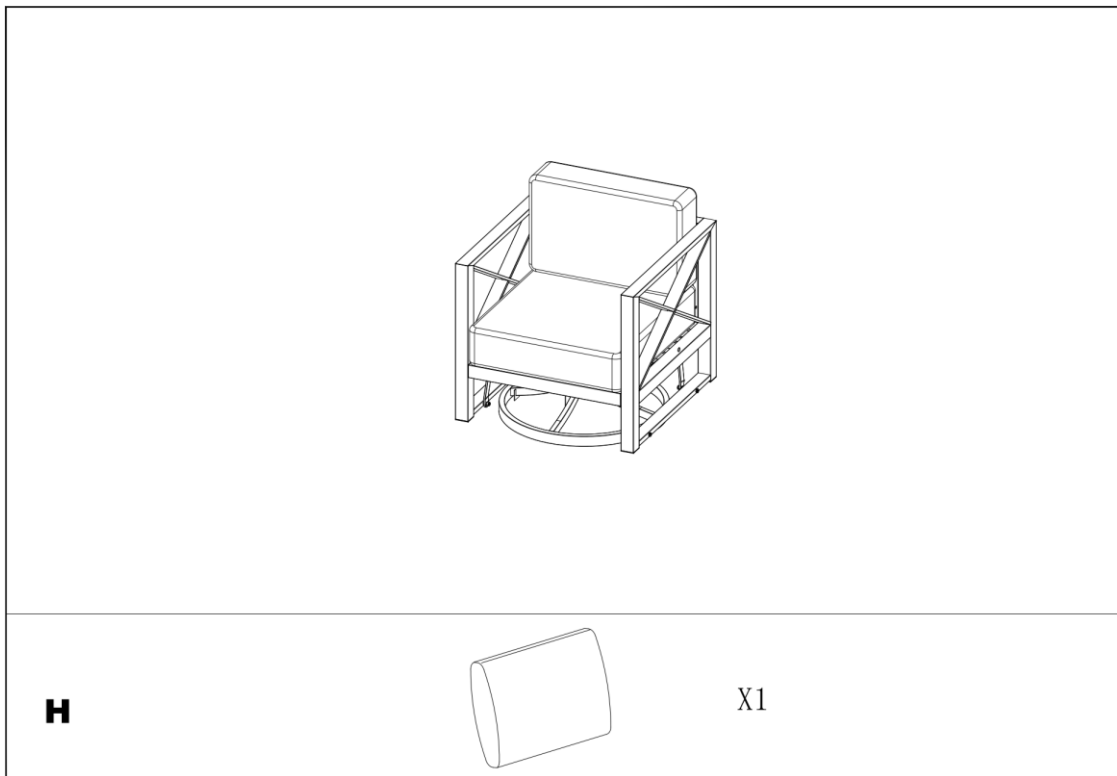

**L'assemblage est terminé, le canapé est prêt à être utilisé.**

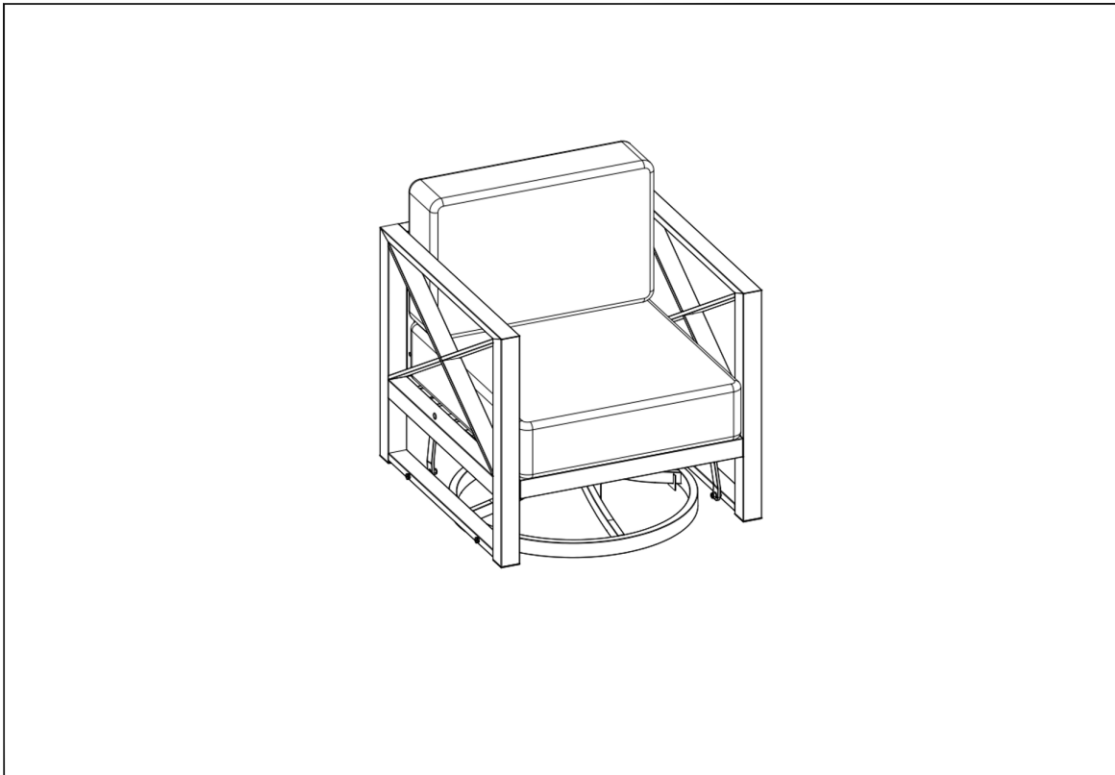

## **NETTOYAGE ET ENTRETIEN**

### **CADRE**

**Nettoyage** - Utilisez du savon doux et de l'eau tiède. N'utilisez pas de matériaux abrasifs, de nettoyeurs ou de produits à base de javel. Rincez à l'eau propre et séchez soigneusement.

**Entretien** - Nettoyez périodiquement et séchez soigneusement. Assurez-vous de vider toute l'eau accumulée à l'intérieur des cadres. Pour vider complètement les cadres, retirez les bouchons de pied et inclinez les cadres si nécessaire pour éliminer toute l'eau. C'est essentiel. L'eau qui s'accumule à l'intérieur des cadres et qui est ensuite exposée à des températures inférieures à zéro peut endommager les tuyaux du cadre. Ce type de dommage n'est pas couvert par la garantie. Nettoyez, videz et séchez toujours soigneusement avant de stocker pour l'hiver. Pour de meilleurs résultats, rangez ou couvrez toujours vos meubles lorsqu'ils ne sont pas utilisés.

Lors du nettoyage ou du déplacement d'articles grands ou lourds, assurez-vous toujours que deux personnes travaillent ensemble. Ne jamais traîner les meubles.

## **TISSU**

**Nettoyage** - Le tissu doit être nettoyé régulièrement. Brossez toute saleté libre et lavez-le avec une solution de savon doux et d'eau tiède. Pour les taches tenaces et la moisissure, lavez avec une solution de 236,6 ml / 1 tasse d'eau de Javel et de 59,2 ml / 0,25 tasse de savon doux pour 3,79 L / 1 gallon d'eau. Rincez abondamment pour éliminer le savon. Laissez le tissu sécher à l'air.

**Entretien** - La meilleure façon de maintenir la beauté des coussins et des hamacs est de les stocker dans un endroit sec et à l'abri des intempéries lorsqu'ils ne sont pas utilisés, ou de les couvrir avec des housses de meubles extérieurs disponibles dans le commerce.

## **COUSSIN**

Pour garantir la longévité de votre ensemble de patio, chaque coussin de siège est fabriqué avec de la mousse haute densité. Lors des premières utilisations, les coussins de siège peuvent sembler fermes, mais avec une utilisation continue, ils vont progressivement se ramollir et offrir un confort optimal pour les saisons à venir. Les coussins peuvent devenir saturés d'eau avec une exposition prolongée à l'humidité. Pour permettre un séchage adéquat des coussins, suivez les étapes suggérées :

- \* Dézippez la housse du coussin pour aérer et faciliter le processus de séchage. Ne retirez pas les housses des coussins.
- \* Placez les coussins en position verticale pour un drainage plus rapide. La fermeture éclair de ventilation doit être orientée vers le bas.
- \* Rangez les coussins à l'intérieur pendant la saison des pluies et par mauvais temps.

# Instrucciones de montaje y cuidado

## SILLA GIRATORIA

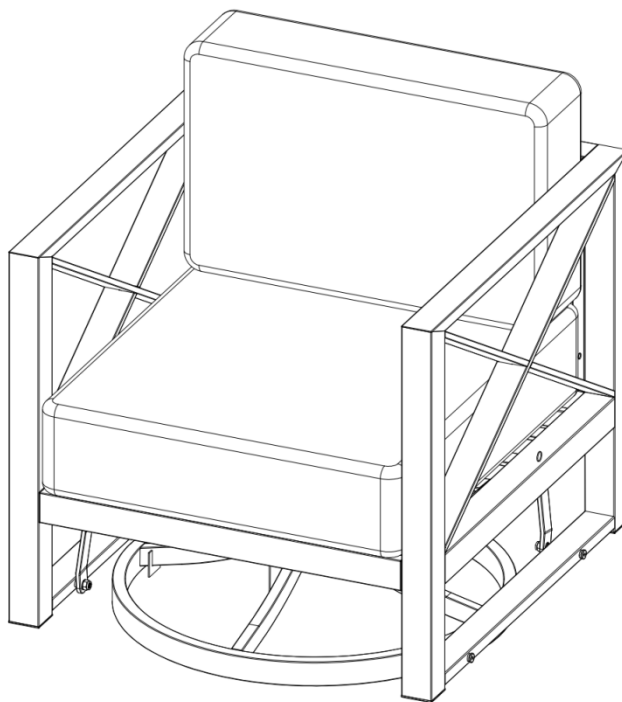

### **IMPORTANTE**

**POR FAVOR LEA ESTO ANTES DE COMENZAR EL MONTAJE**

---

Siga las pautas de esta guía del usuario para asegurar un montaje correcto y el cuidado de este producto.

## **LEA TODAS LAS INSTRUCCIONES ANTES DE USAR**

Al utilizar estos muebles, siga siempre las precauciones básicas, incluidas las siguientes:

Lea todas las instrucciones antes de usar este juego.

Para reducir el riesgo de lesiones a las personas:

- No utilice este juego en terreno blando.
- No se pare ni permita que los niños se paren sobre las sillas, el sofá, la otomana o la fogata ensamblados.
- Después del ensamblaje, verifique que todas las conexiones de hardware estén seguras antes de poner el producto en uso.
- La instalación, ajuste, alteración, servicio o mantenimiento inadecuados pueden causar lesiones o daños a la propiedad.
- Lea detenidamente todas las instrucciones de instalación, operación y mantenimiento antes de instalar o reparar este equipo.

## **PLANIFICACIÓN DEL MONTAJE**

Antes de comenzar el montaje, vacíe completamente el contenido de la caja y retire todo el material de embalaje. Asegúrese de que todas las piezas y el hardware estén presentes. Si falta alguna pieza o tiene preguntas sobre daños, contáctenos a tiempo, nuestro equipo de postventa le responderá en 24 horas.







Por favor, tome fotos del número de SKU y de la etiqueta WA antes de abrir las cajas. Si encuentra algún problema, envíenos los detalles junto con las fotos mencionadas anteriormente. Esto nos ayudará a resolver el problema más rápidamente.



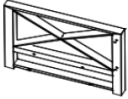

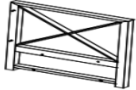
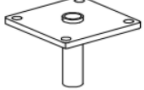

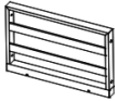





## CONTENIDO DEL PAQUETE - 1 SILLÓN GIRATORIO

**NOTA:** Coloque todas las piezas sobre una superficie suave, no abrasiva y nivelada para el montaje. No apriete demasiado las conexiones de hardware.

## PASOS DE INSTALACIÓN DE LA SILLA GIRATORIA

### LISTA DE PIEZAS DE LA SILLA GIRATORIA

Parte	Descripción	Qty(pcs)	Parte	Descripción	Qty(pcs)
A		1	F		1
B		1	G		1
C		1	H		1
D		1	I		1
E		1			

Parte	Descripción	Qty(pcs)	Part	Descripción	Qty(pcs)	Parte	Descripción	Qty(pcs)
AA	 M6*35	11	FF	 M8	4	KK	 M8	8
BB	 M8*25	4	GG	 M6	1	LL		1
CC	 M8*50	4	HH	 M8	12	MM		1
DD	 M6	10	II	 M6 Ø29	1			
EE	 M8	4	JJ	 M6/M8	23			

**PASO 1: Conecta el reposabrazos derecho (A) a la placa del asiento (C).**

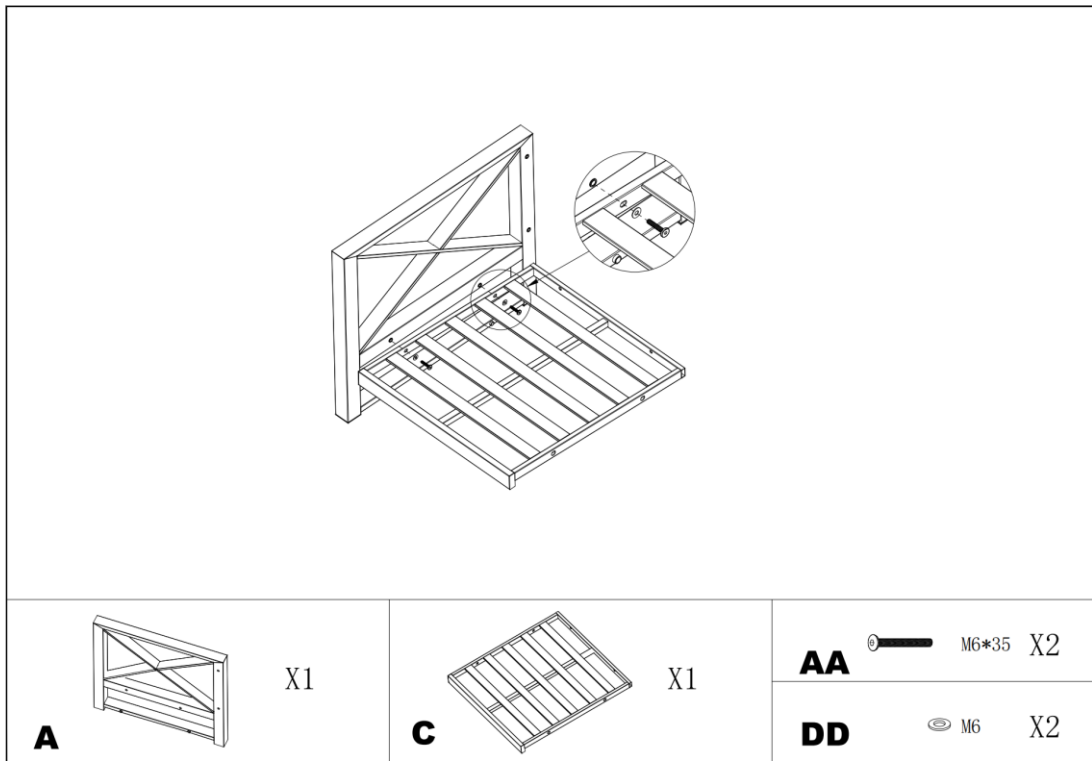

**PASO 2: Conecta el reposabrazos izquierdo (B) a la placa del asiento.**

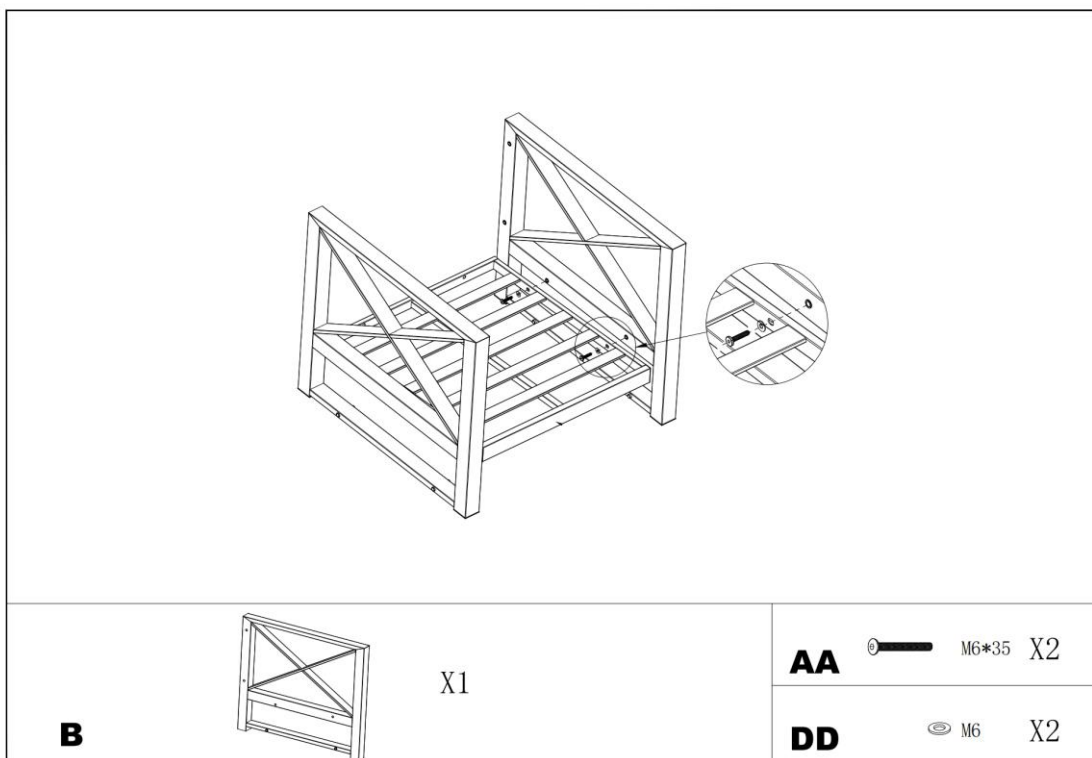

**PASO 3: Fija el respaldo (D) a la placa de base y al reposabrazos.**

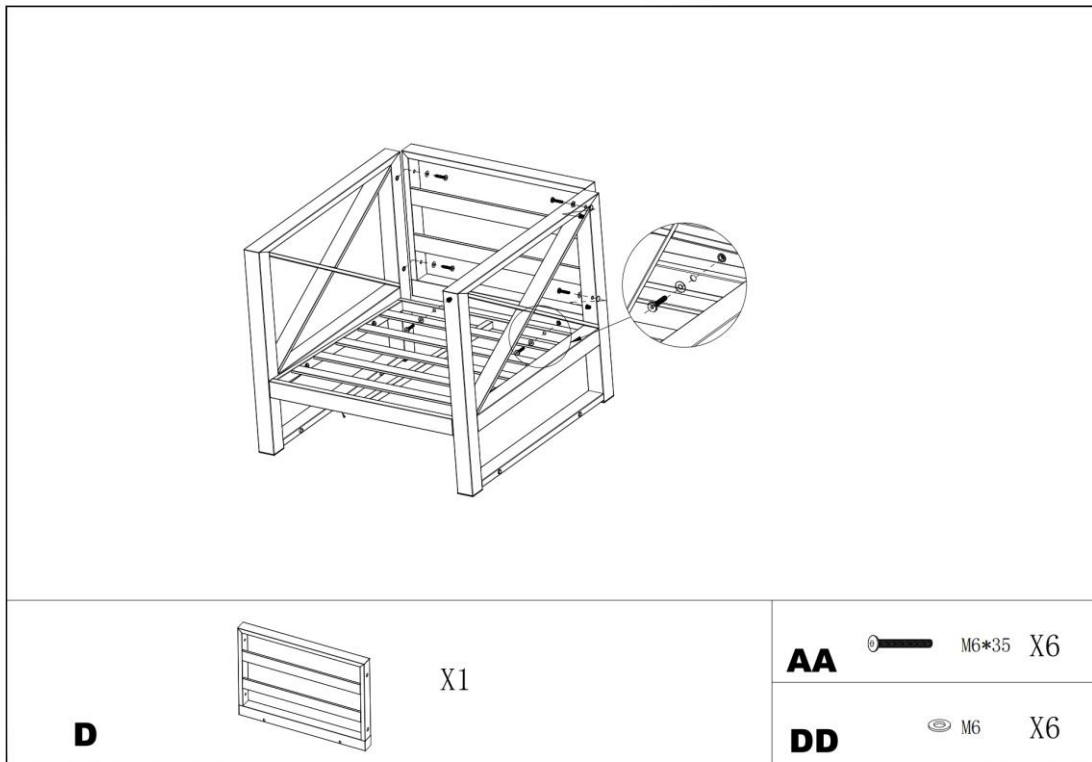

**PASO 4: Conecta la barra en H (E) y el eje (G).**

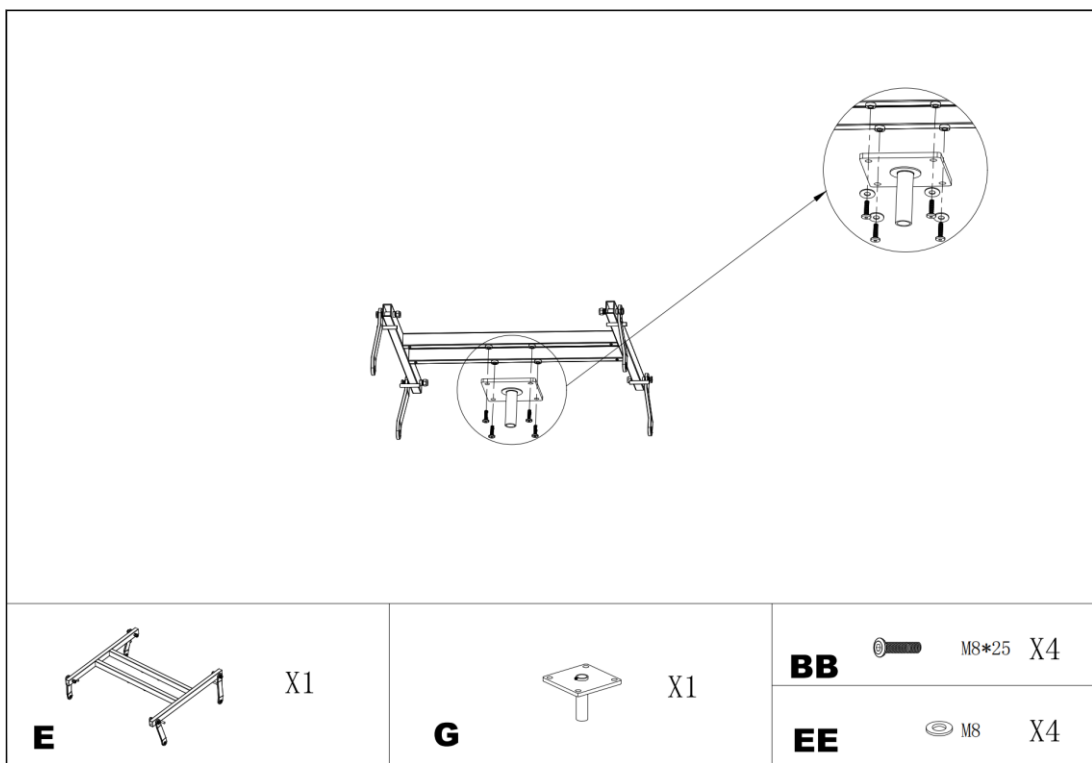

**PASO 5: Conecta el eje (G) con la base de la silla (F).**

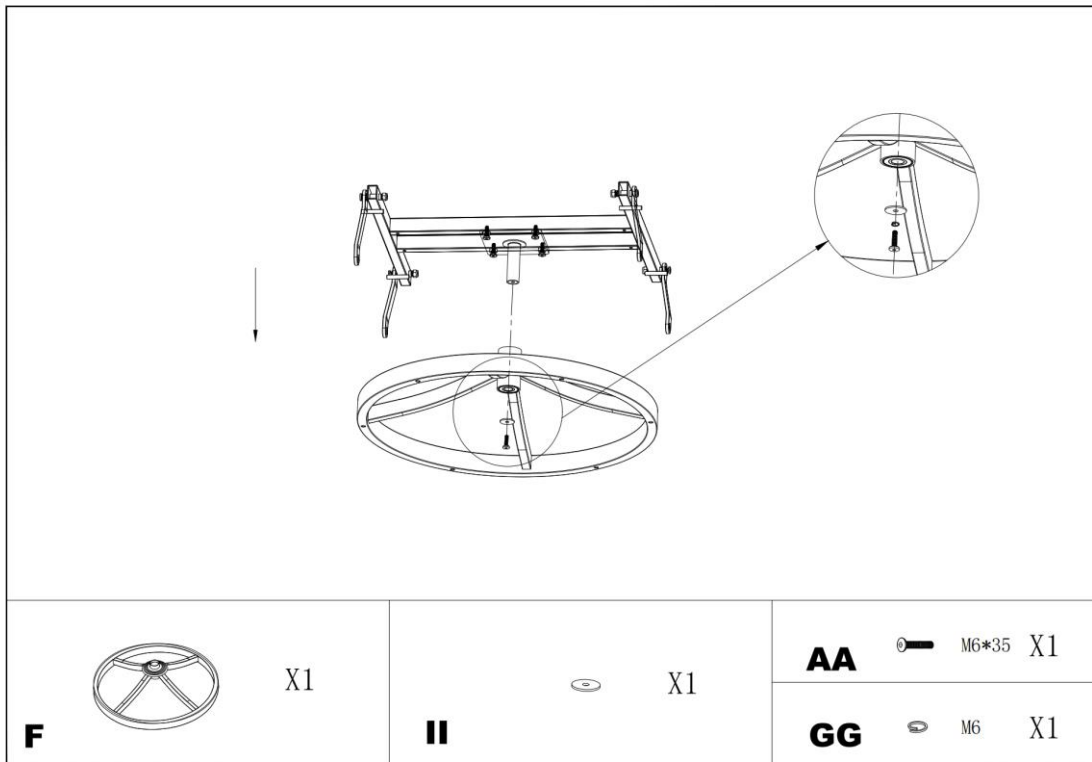

**PASO 6: Conecta la base de la silla y la silla.**

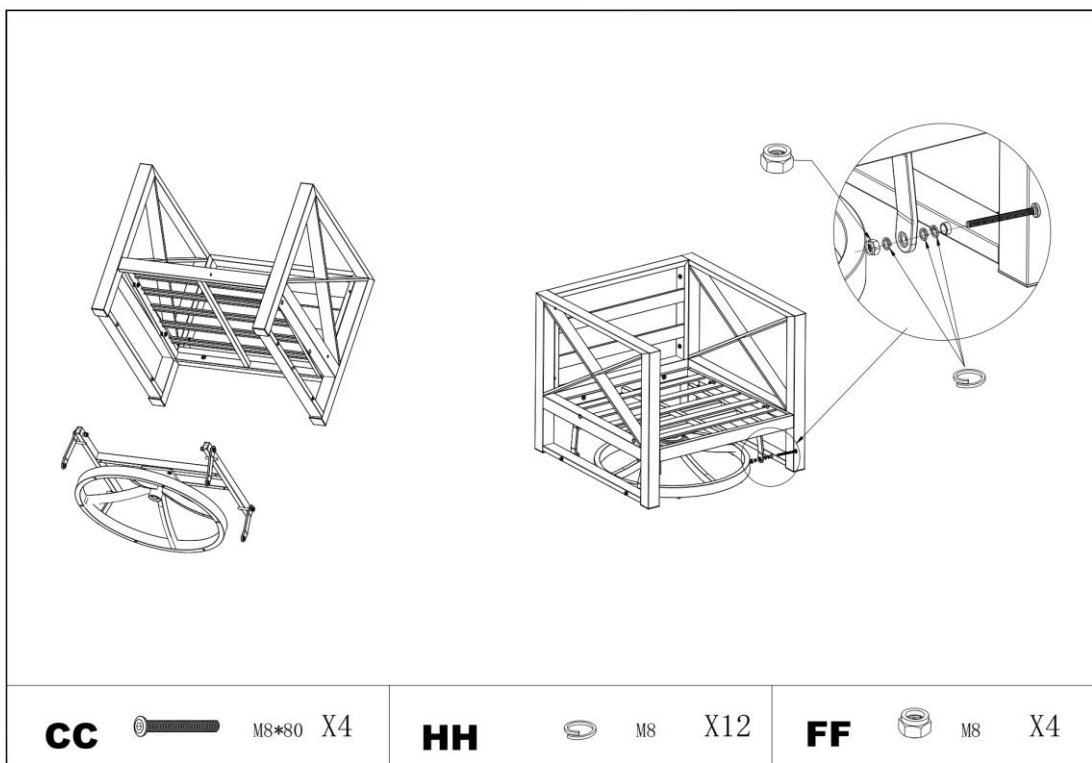

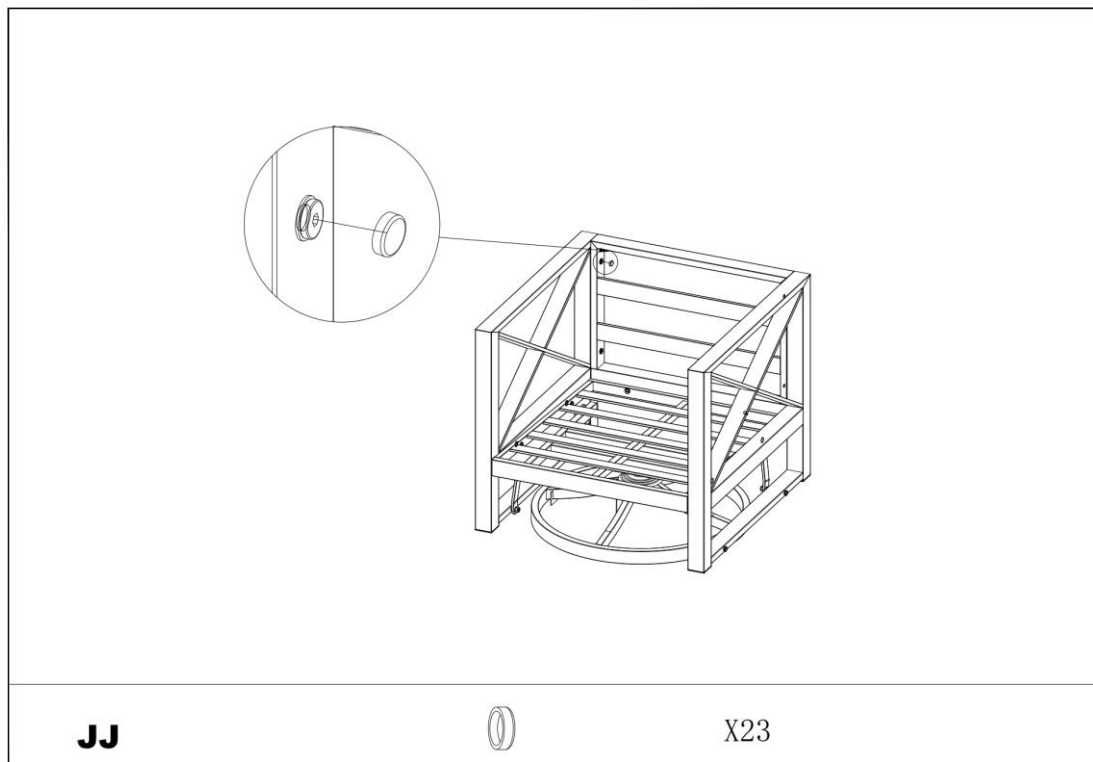
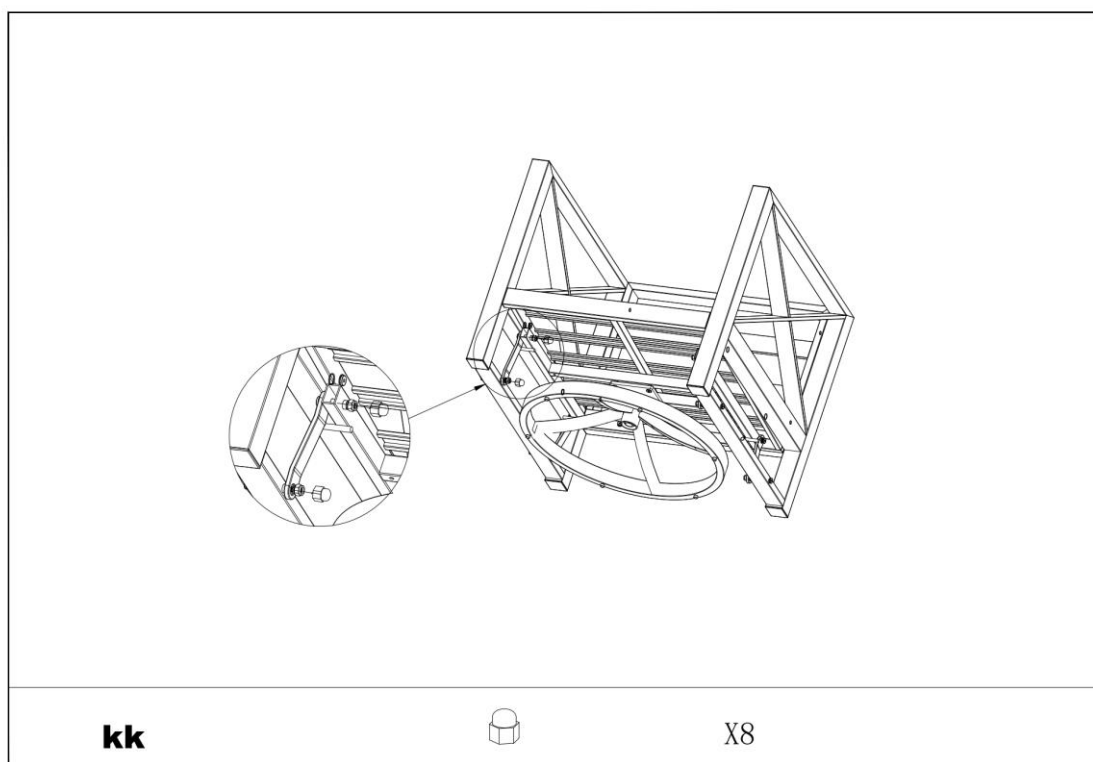
**PASO 7: Pon las tapas de tornillo en los tornillos.****PASO 8: Pon las tapas de tuercas en las tuercas.**

**PASO 9: Coloca el cojín del asiento (I).**

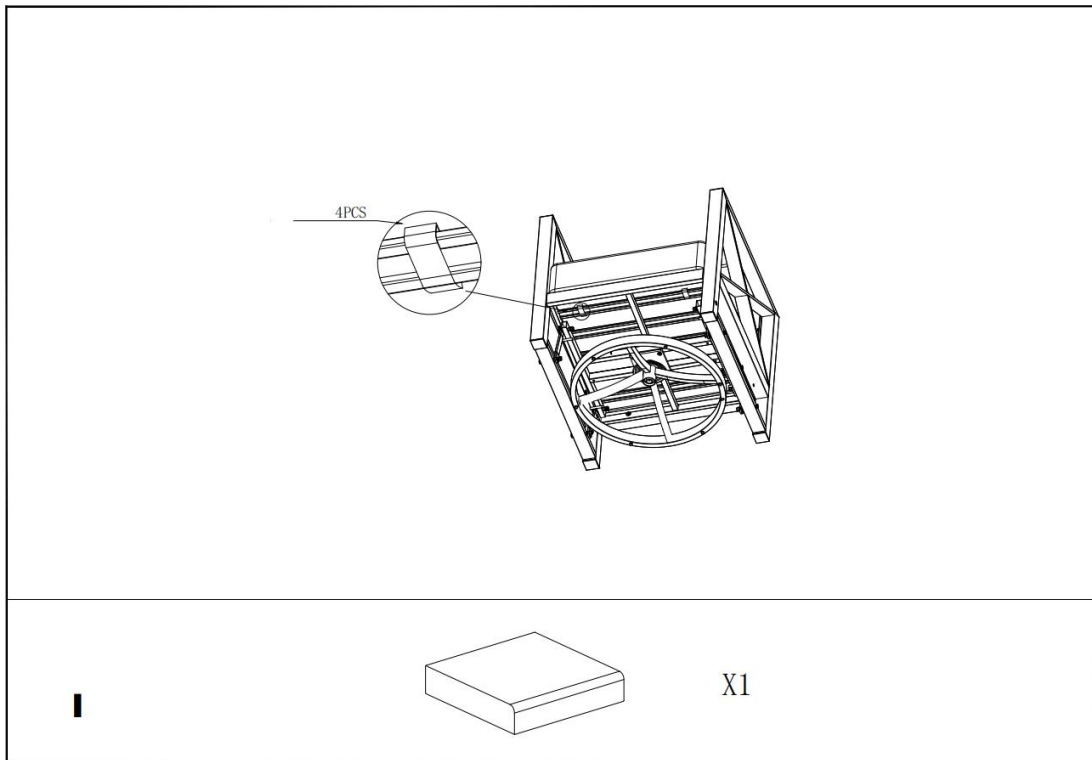

**PASO 10: Coloca el cojín del respaldo (H).**

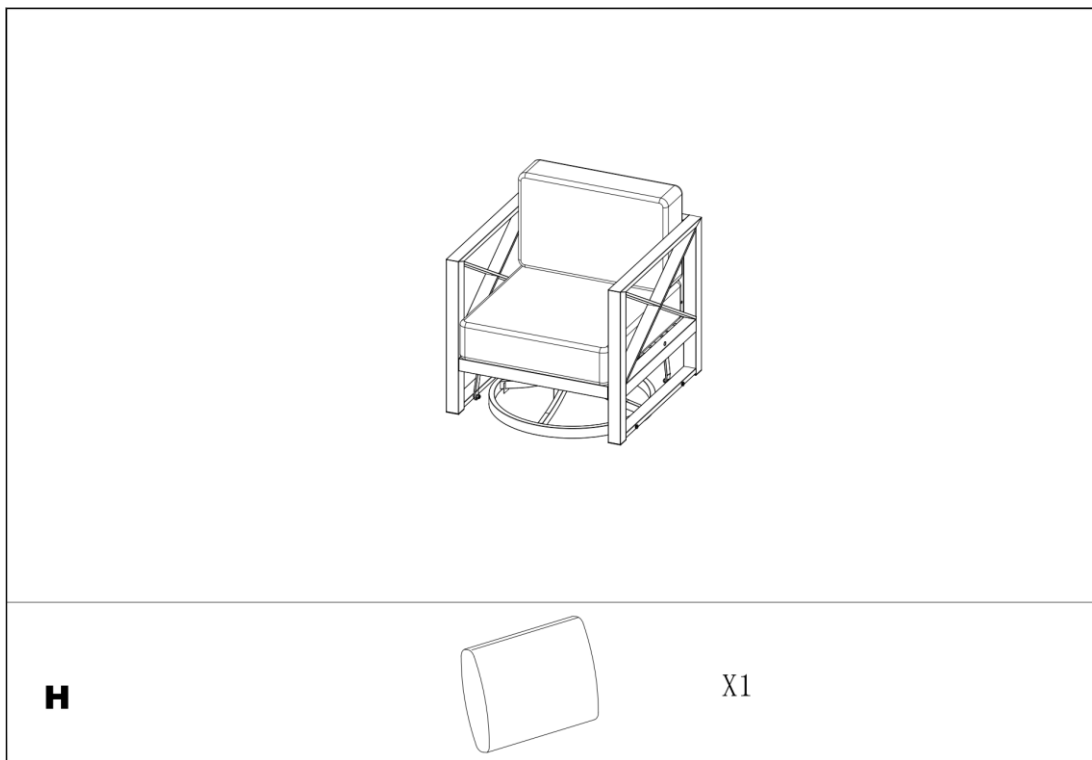

**\*\*El montaje está completo y el sofá está listo para su uso.**

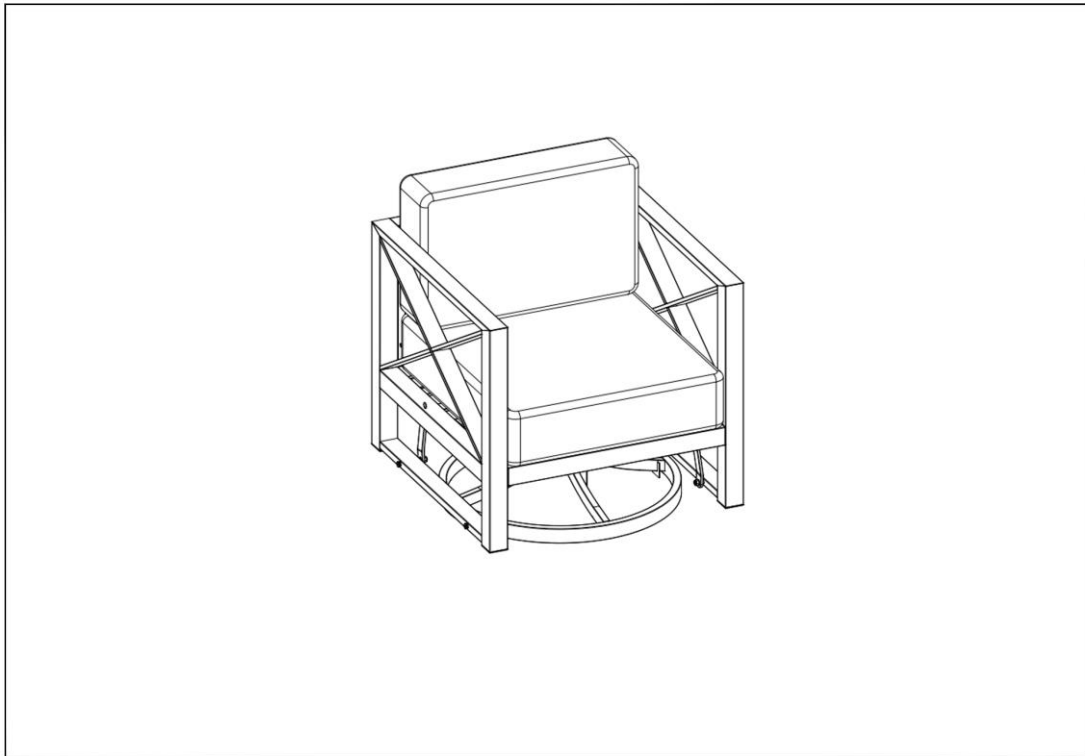

## **LIMPIEZA Y MANTENIMIENTO**

### **MARCO**

**Limpieza:** Utilice jabón suave y agua tibia. No utilice materiales abrasivos, limpiadores o productos de blanqueo. Enjuague con agua limpia y seque completamente.

**Mantenimiento:** Limpie y seque periódicamente. Asegúrese de drenar cualquier agua que se haya acumulado dentro del marco. Para drenar completamente el marco, retire las tapas de los pies y, si es necesario, incline el marco para eliminar toda el agua. Esto es fundamental. El agua que se acumula dentro del marco y luego se expone a temperaturas por debajo del punto de congelación puede causar daños al tubo del marco. Estos daños no están cubiertos por la garantía. Siempre limpie, drene y seque completamente antes de almacenar el mobiliario durante el invierno. Para obtener los mejores resultados, siempre almacene o cubra su mobiliario

cuando no lo use. \*\* Cuando limpie o mueva objetos grandes o pesados, siempre trabajen dos personas juntas. Nunca tire el mobiliario.

### **TELA (COJINES)**

**Limpieza:** La tela debe limpiarse regularmente. Cepille cualquier suciedad suelta y lave con una solución de jabón suave y agua tibia. Para manchas obstinadas y moho, lave con una solución de 236,6 ml / 1 taza de blanqueador y 59,2 ml / 0,25 taza de jabón suave por cada 3,79 L / 1 galón de agua. Enjuague completamente para eliminar el jabón. Deje secar la tela al aire.

**Mantenimiento:** La mejor manera de mantener la belleza de los cojines y los tirantes es almacenarlos en un área seca y protegidos del tiempo cuando no se usan, o cubrirlos con cubiertas comerciales para mobiliario exterior.

### **COJINES**

Para garantizar la longevidad de su juego de patio, cada cojín de asiento está hecho con espuma de alta densidad. En el uso inicial, los cojines de asiento pueden parecer firmes, pero con el uso continuo, los cojines se irán ablandando y proporcionando el máximo confort en las temporadas venideras.

Los cojines pueden quedar saturados de agua con una exposición prolongada a la lluvia. Para permitir que los cojines se sequen al aire correctamente, siga los pasos sugeridos:

- \* Abra la cremallera de la funda del cojín para ventilarlo y facilitar el proceso de secado. No retire las fundas de los cojines.
- \* Coloque los cojines en posición vertical para un drenaje más rápido. La cremallera de ventilación debe estar hacia abajo.
- \* Almacene los cojines en interiores durante las estaciones de lluvia y tiempo inclemente.

# Istruzioni di montaggio e cura

## SEDIE GIREVOLI

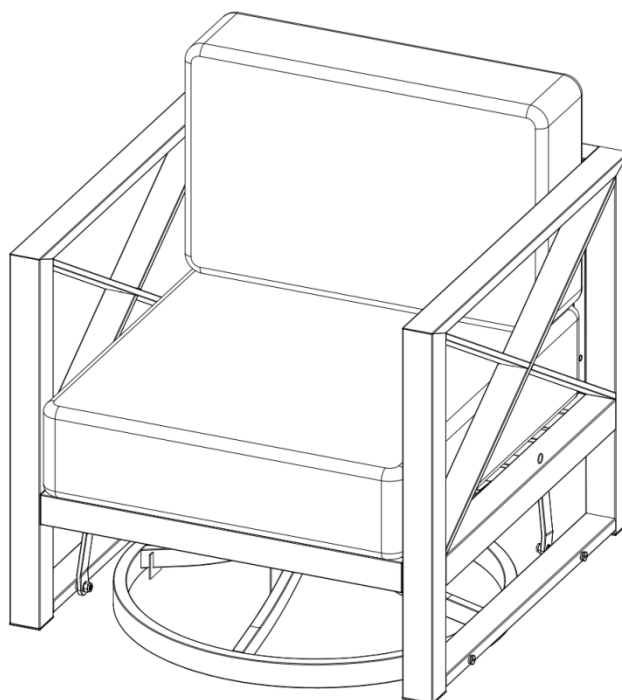

### **IMPORTANTE**

---

#### **LEGGI QUESTO PRIMA DI INIZIARE L'ASSEMBLAGGIO**

Seguire le linee guida in questa guida utente per garantire un corretto  
assemblaggio e cura di questo prodotto.

## **LEGGERE TUTTE LE ISTRUZIONI PRIMA DELL'USO**

Quando si utilizzano questi arredi, seguire sempre le precauzioni di base, incluse le seguenti:

Leggere tutte le istruzioni prima di utilizzare questo set.

Per ridurre il rischio di lesioni alle persone:

- Non utilizzare questo set su un terreno soffice.
- Non stare in piedi o permettere ai bambini di stare in piedi sulle sedie, sul divano, sul pouf o sul braciere assemblati.
- Dopo il montaggio, verificare che tutti i collegamenti hardware siano sicuri prima di mettere in uso il prodotto.
- L'installazione, la regolazione, l'alterazione, l'assistenza o la manutenzione impropria possono causare lesioni o danni materiali.
- Leggere attentamente tutte le istruzioni di installazione, funzionamento e manutenzione prima di installare o sottoporre a manutenzione questa apparecchiatura.

## **PIANIFICAZIONE DEL MONTAGGIO**

Prima di iniziare il montaggio, svuotare completamente il contenuto della scatola e rimuovere tutto il materiale di imballaggio. Assicurarsi che tutte le parti e gli accessori siano presenti. Se mancano parti o se avete domande riguardo a danni, contattateci tempestivamente. Il nostro team di assistenza post-vendita risponderà entro 24 ore.







Si prega di scattare foto del numero SKU e dell'etichetta WA prima di aprire le scatole. Se riscontri un problema, inviaci i dettagli con le foto sopra indicate. Questo ci aiuterà a risolvere il problema più rapidamente.



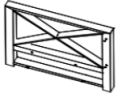

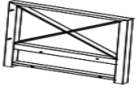



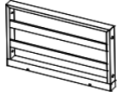
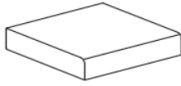
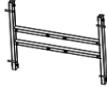



## CONTENUTO DELLA CONFEZIONE - 1 SEDIA GIREVOLE

**NOTA:** Posizionare tutte le parti su una superficie morbida, non abrasiva e livellata per il montaggio. Non stringere eccessivamente le connessioni hardware.

## PASSAGGI PER L'INSTALLAZIONE DELLA SEDIA GIREVOLE

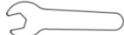
### LISTA DELLE PARTI

Parte	Descrizione	Qty(pcs)	Parte	Descrizione	Qty(pcs)
A		1	F		1
B		1	G		1
C		1	H		1
D		1	I		1
E		1			

Parte	Descrizione	Qty(pcs)	Part	Descrizione	Qty(pcs)	Parte	Descrizione	Qty(pcs)
AA	 M6*35	11	FF	 M8	4	KK	 M8	8
BB	 M8*25	4	GG	 M6	1	LL		1
CC	 M8*80	4	HH	 M8	12	MM		1
DD	 M6	10	II	 M6 Ø29	1			
EE	 M8	4	JJ	 M6/M8	23			

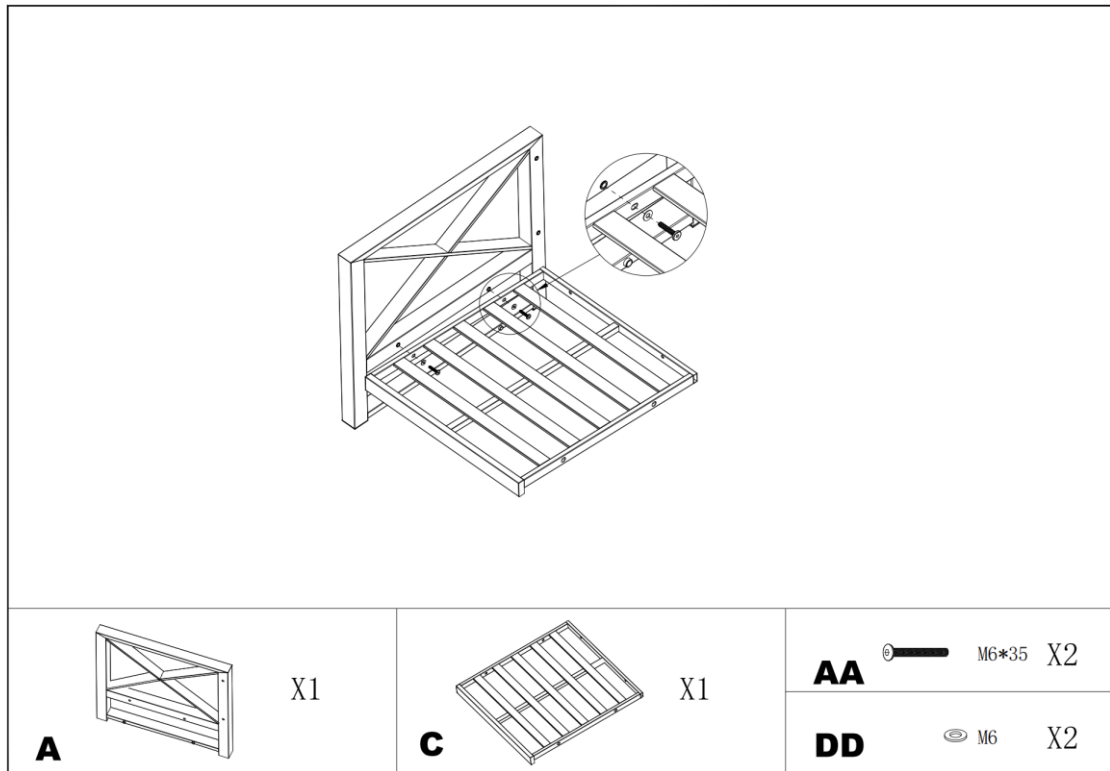
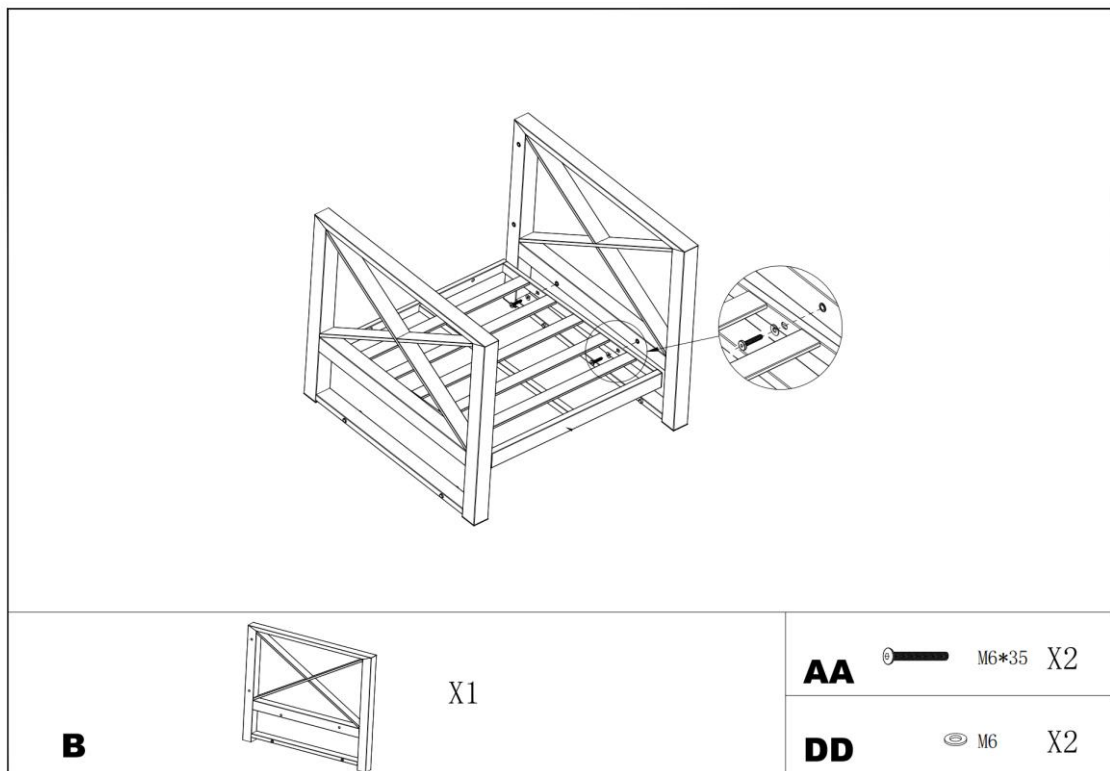
**PASSO 1: Collega il bracciolo destro (A) alla piastra del sedile (C).****PASSO 2: Collega il bracciolo sinistro (B) alla piastra del sedile.**

**PASSO 3: Attacca il schienale (D) alla piastra di base e al bracciolo.**

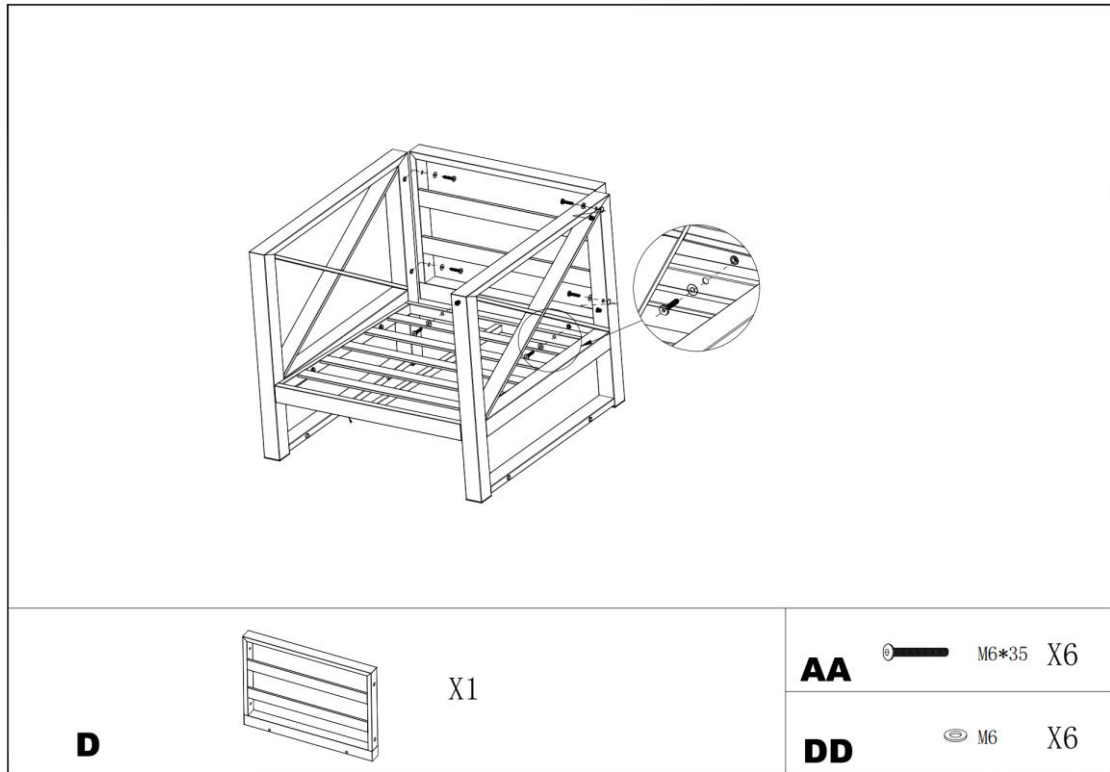

**PASSO 4: Collega la staffa a forma di H (E) e l'albero (G).**

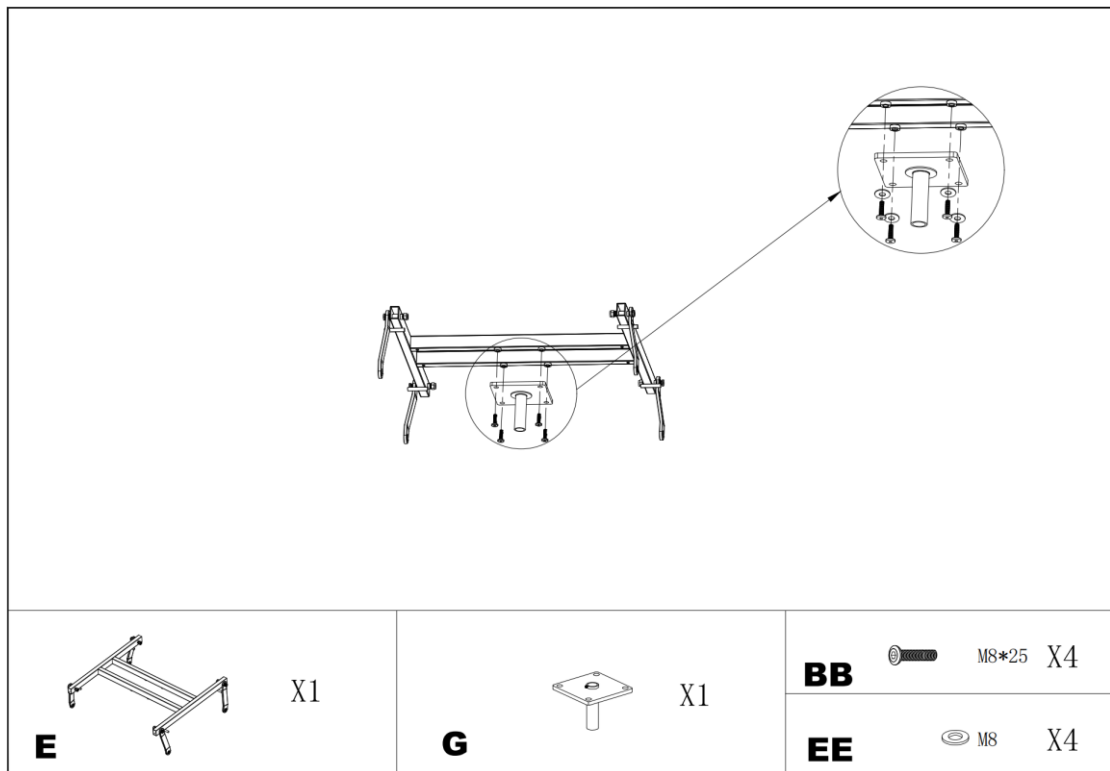

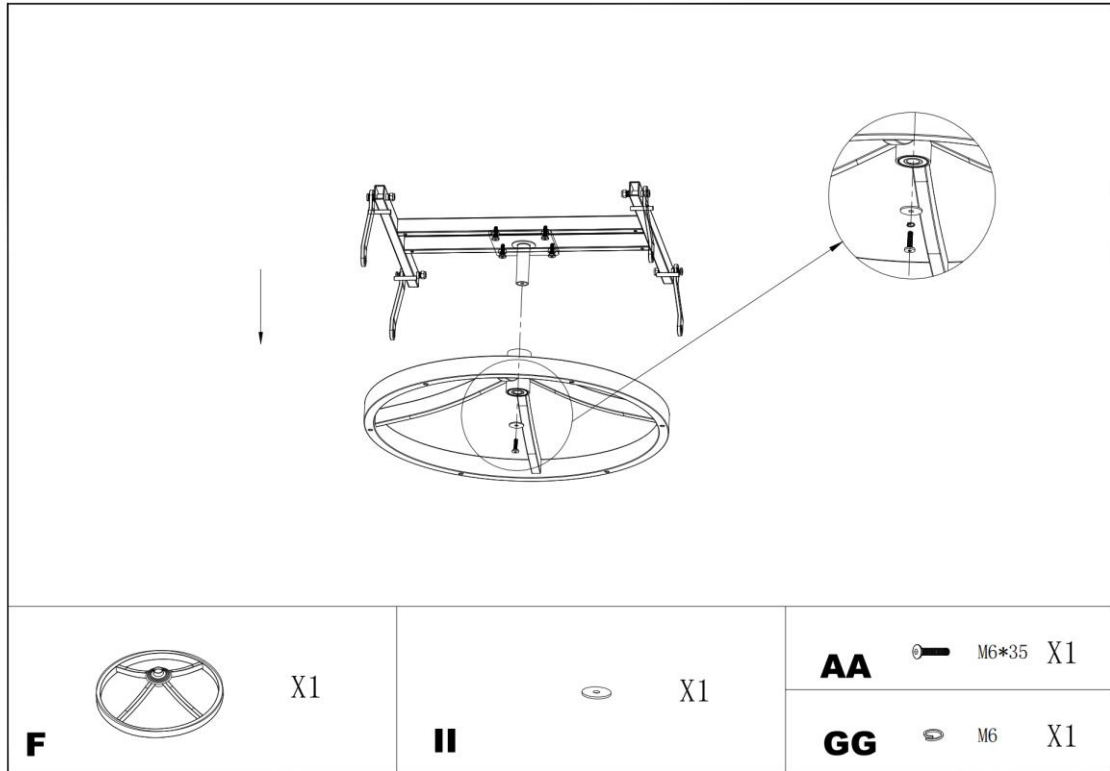
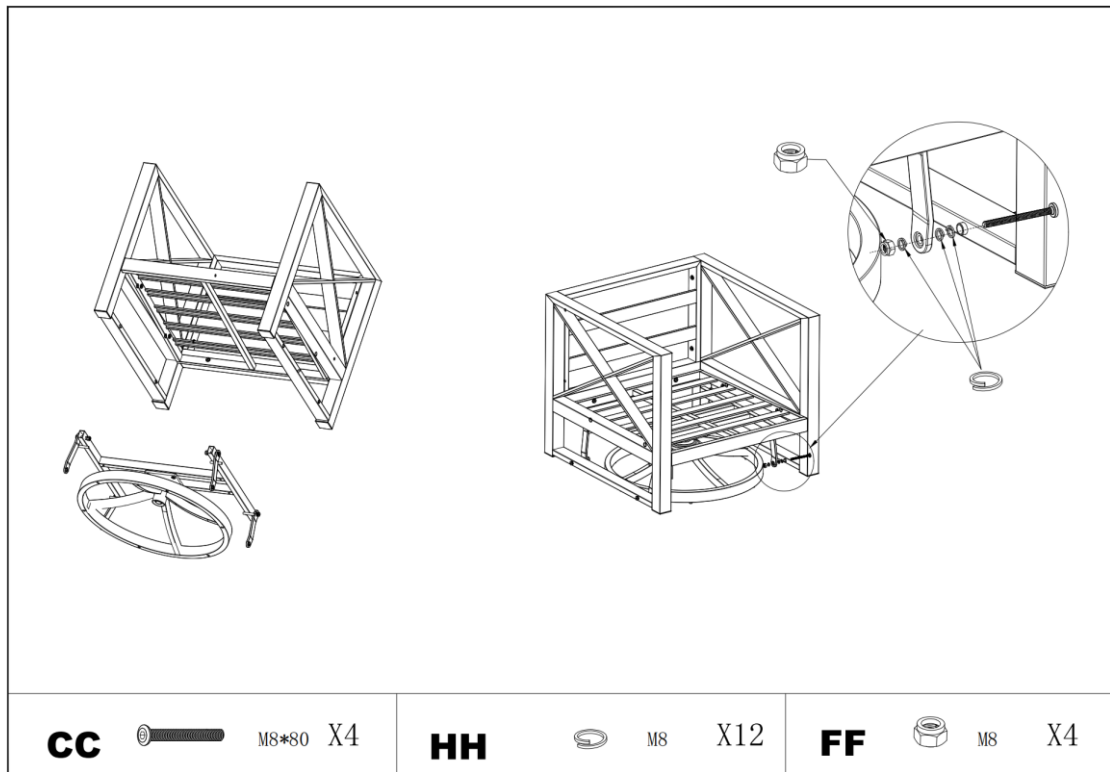
**PASSO 5: Collega l'albero (G) alla base della sedia (F).****PASSO 6: Collega la base della sedia e la poltrona.**

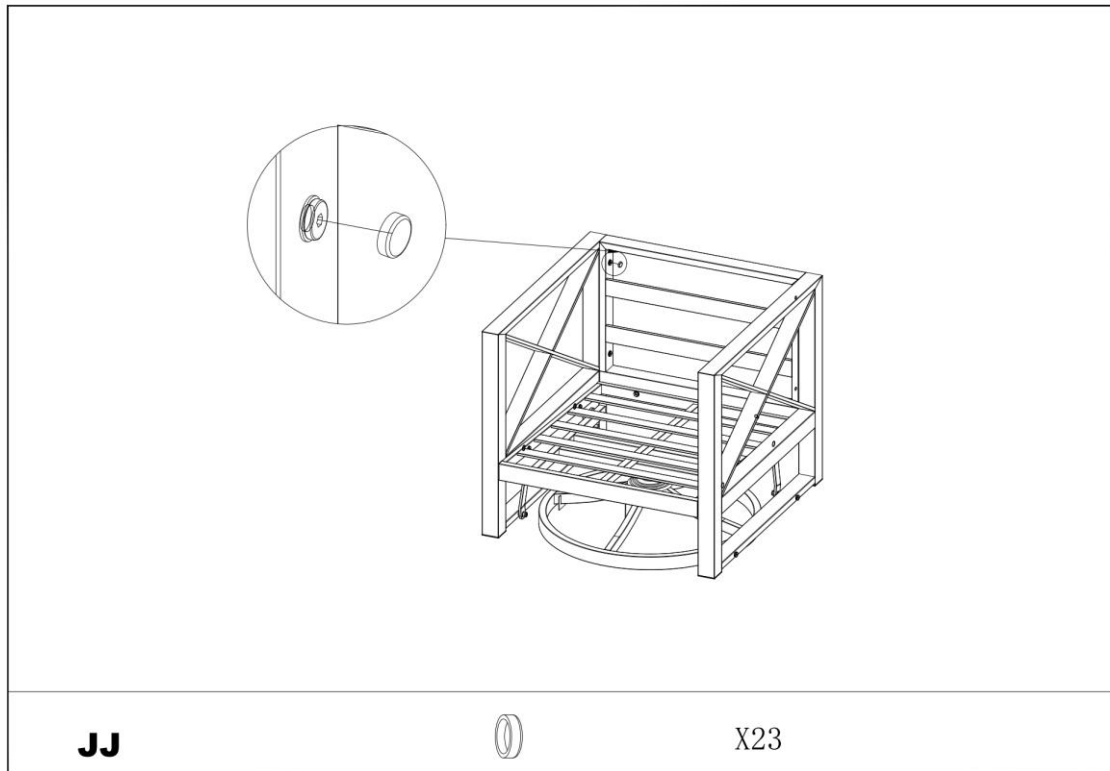
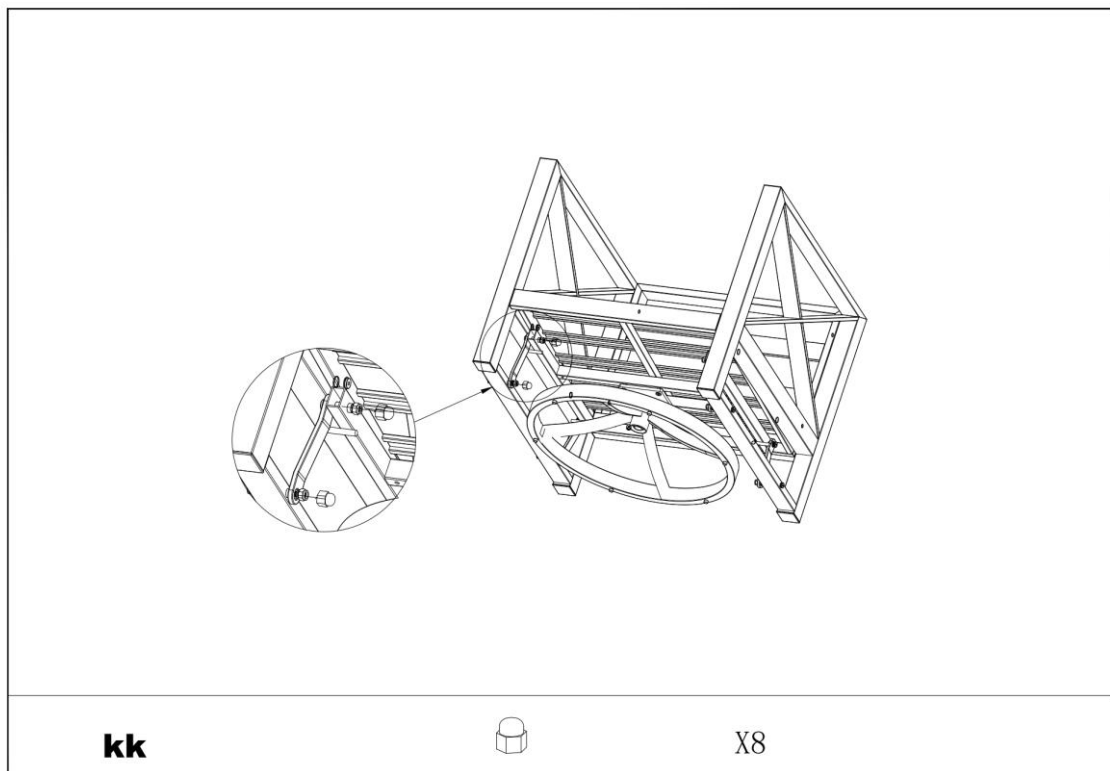
**PASSO 7: Metti le cuffie per viti sulle viti.****PASSO 8: Metti le cuffie per dadi sui dadi.**

**PASSO 9: Posiziona il cuscino del sedile (I).**

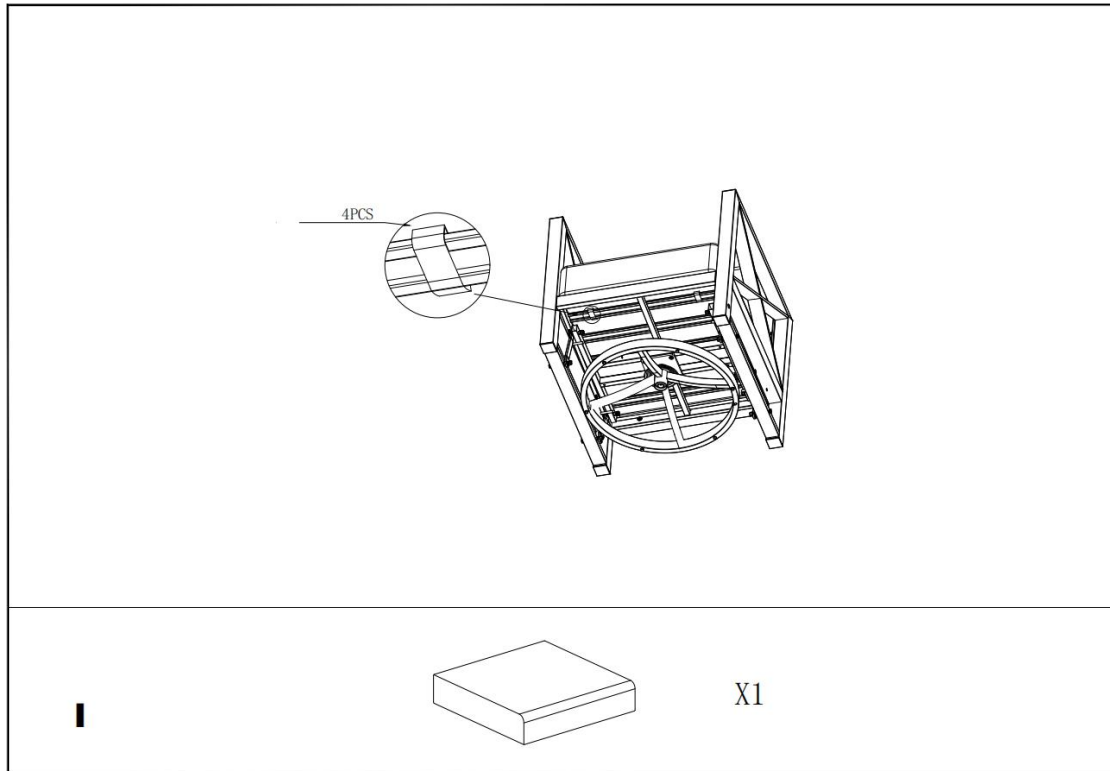

**PASSO 10: Posiziona il cuscino del schienale (H).**

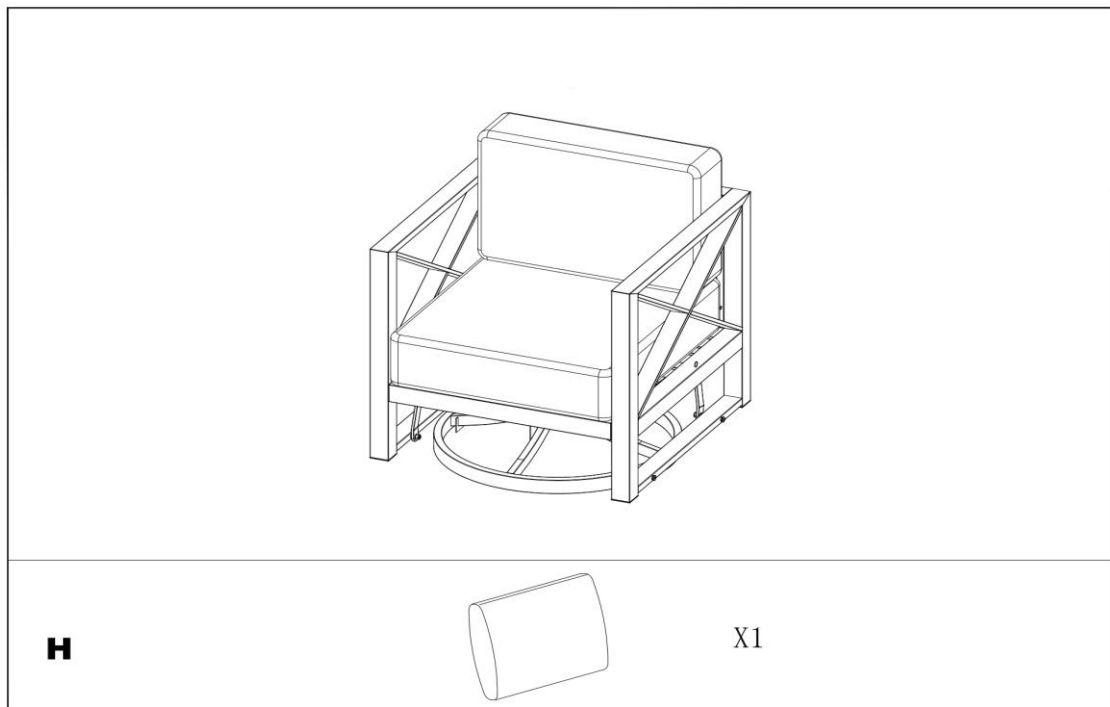

**\*\*L'assemblaggio è completo, il divano è pronto per l'uso.**

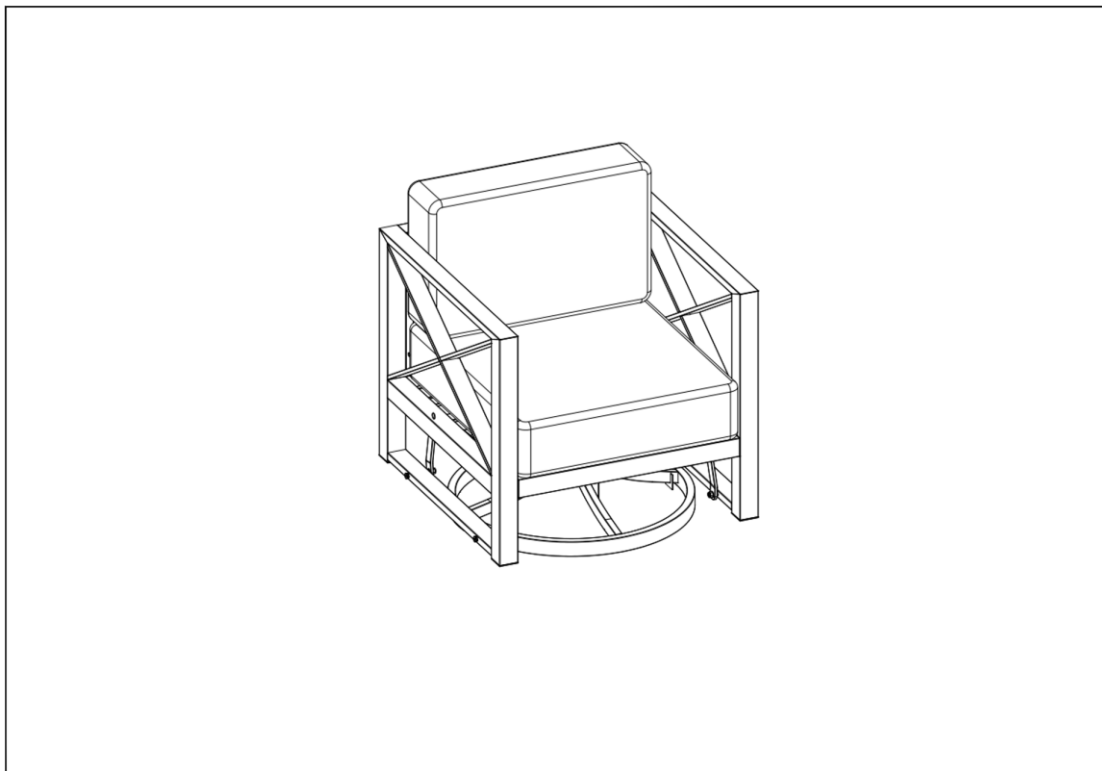

## **PULIZIA E MANUTENZIONE**

### **TELAIO**

**Pulizia** - Usa sapone delicato e acqua calda. Non utilizzare materiali abrasivi, detersivi o prodotti contenenti candeggina. Risciacquare con acqua pulita e asciugare accuratamente.

**Manutenzione** - Pulire periodicamente e asciugare accuratamente. Assicurarsi di drenare qualsiasi acqua accumulata all'interno dei telai. Per drenare completamente i telai, rimuovere i tappi dei piedi e inclinare i telai, se necessario, per rimuovere tutta l'acqua. Questo è fondamentale. L'acqua che si accumula all'interno dei telai e che poi viene esposta a temperature sotto lo zero può danneggiare i tubi del telaio. Tale danno non è coperto dalla garanzia. Pulisci, drena e asciuga accuratamente prima di riporre per l'inverno. Per ottenere i migliori risultati, conserva o copri sempre i tuoi mobili quando non vengono utilizzati.

Quando si puliscono o si spostano oggetti grandi o pesanti, due persone devono sempre lavorare insieme. Non trascinare mai i mobili.

## **TESSUTO**

**Pulizia** - Il tessuto deve essere pulito regolarmente. Spazzolare via lo sporco libero e lavare con una soluzione di sapone delicato e acqua tiepida. Per le macchie ostinate e la muffa, lavare con una soluzione di 236,6 ml / 1 tazza di candeggina e 59,2 ml / 0,25 tazza di sapone delicato per ogni 3,79L / 1 gallone di acqua. Risciacquare accuratamente per rimuovere il sapone. Lasciare asciugare il tessuto all'aria.

**Manutenzione** - Il modo migliore per mantenere la bellezza dei cuscini e delle reti è conservarli in un'area asciutta e protetta dalle intemperie quando non vengono utilizzati, oppure coprirli con coperture commerciali per mobili da esterno.

## **CUSCINO**

Per garantire la longevità del tuo set da patio, ogni cuscino del sedile è realizzato con schiuma ad alta densità. Con l'uso iniziale, i cuscini del sedile possono sembrare rigidi, ma con l'uso continuo, i cuscini diventeranno progressivamente più morbidi e offriranno il massimo comfort per le stagioni a venire.

I cuscini possono saturarsi d'acqua con una forte esposizione all'acqua. Per consentire ai cuscini di asciugarsi correttamente, seguire i passaggi suggeriti:

\* Aprire la cerniera della copertura del cuscino per ventilare e facilitare il processo di asciugatura. Non rimuovere le fodere dei cuscini.

\* Posizionare i cuscini in posizione verticale per un drenaggio più rapido. La cerniera di ventilazione deve essere rivolta verso il basso.

\* Conservare i cuscini all'interno durante la stagione delle piogge e in caso di maltempo.