

ASSEMBLY INSTRUCTION

Warning: You must read this before continuing

INSTRUCTIONS DE MONTAGE

Attention: Vous devez lire ceci avant de continuer

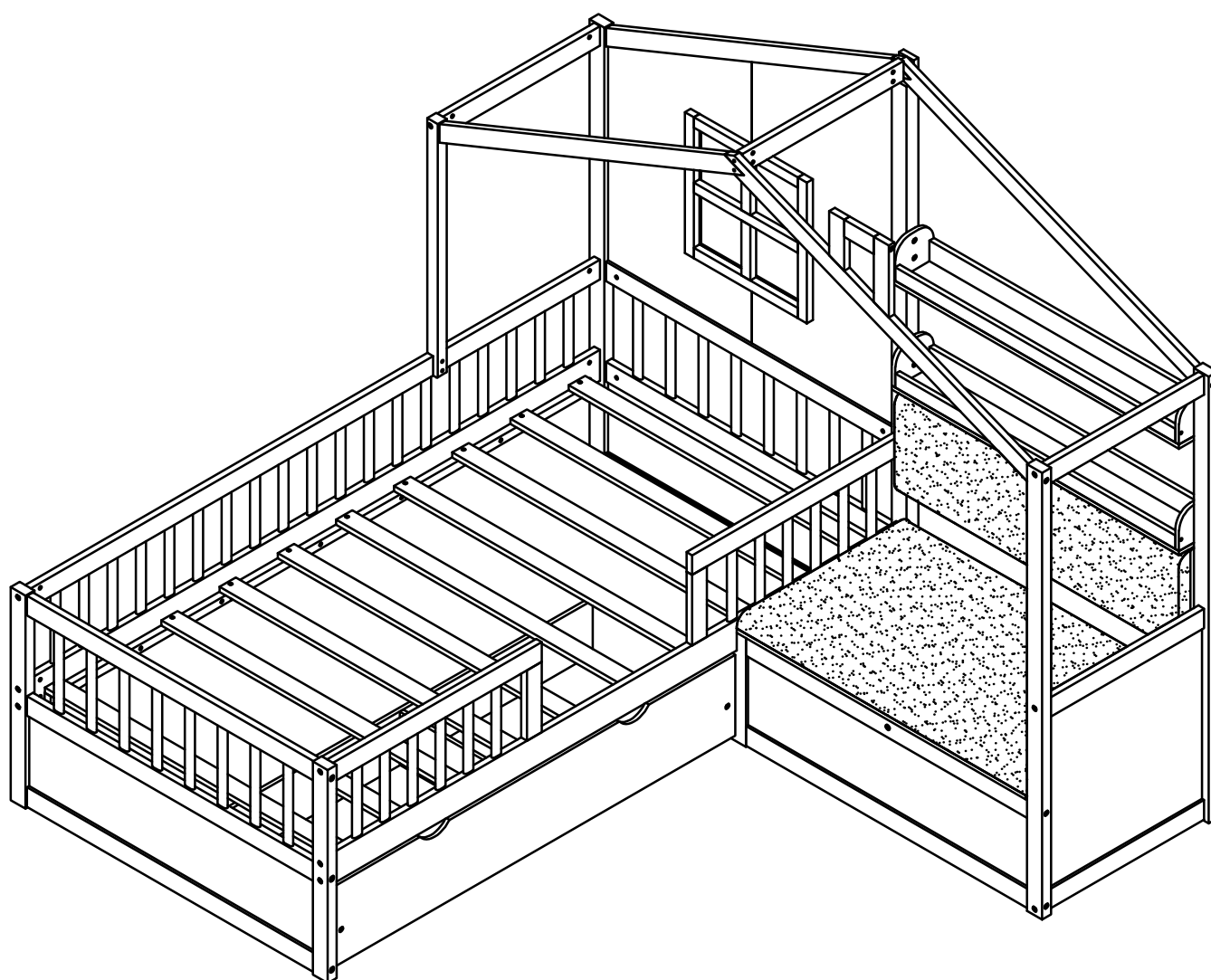

SAFETY WARNINGS AND GENERAL NOTES:

Do not use substitute parts. Contact the manufacturer or dealer for replacement parts.

Keep these instructions for future reference.

We recommend assembling your bed on the shipping carton to protect your floor.

Be certain all staples are out of the box before beginning assembly on the shipping carton.

AVERTISSEMENTS DE SÉCURITÉ ET REMARQUES GÉNÉRALES :

N'utilisez pas de pièces de rechange. Contactez le fabricant ou le revendeur pour les pièces de rechange.

Conservez ces instructions pour référence future.

Nous vous recommandons d'assembler votre lit sur le carton d'expédition pour protéger votre sol.

Assurez-vous que toutes les agrafes sont sorties de la boîte avant de commencer l'assemblage sur le carton d'expédition.





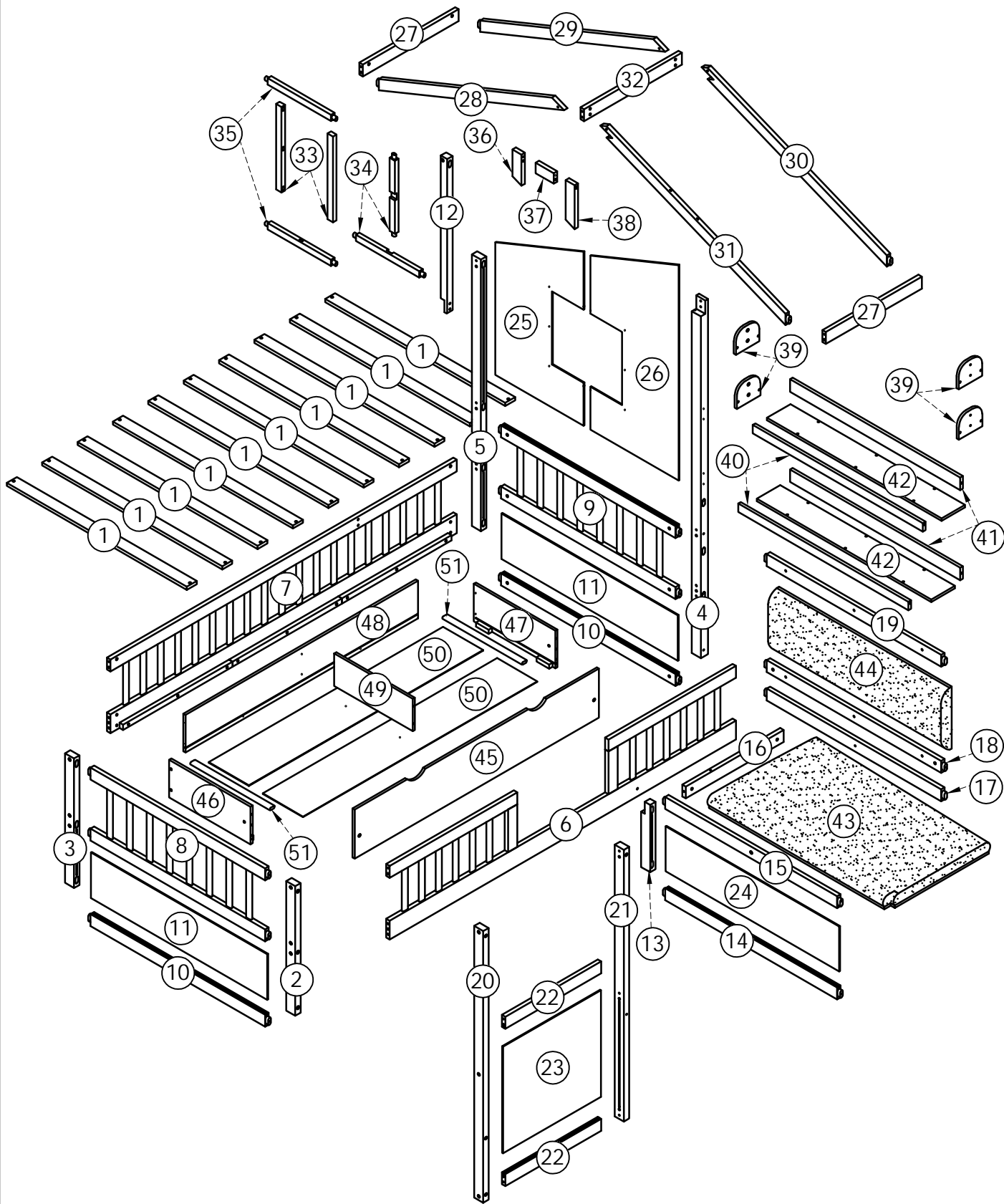





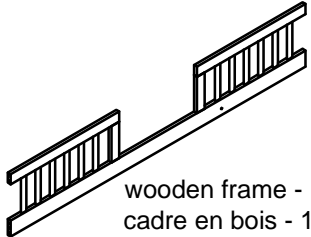
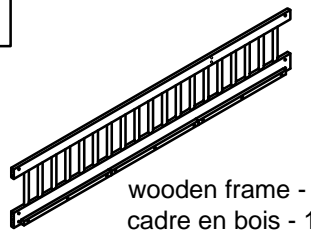
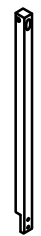

ASSEMBLY INSTRUCTION

INSTRUCTIONS DE MONTAGE

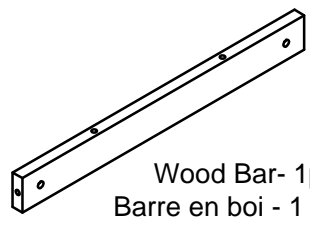

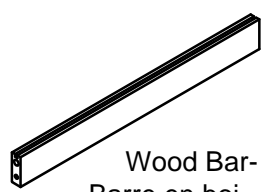
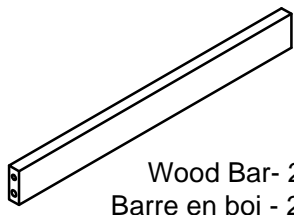
Part List (Box 1)

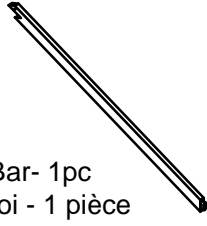
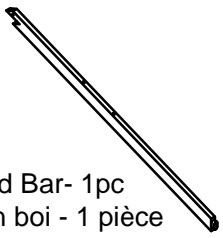
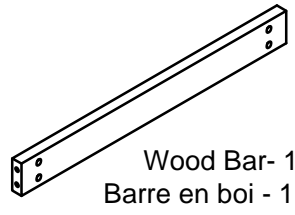
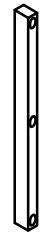
Liste des pièces (Box 1)

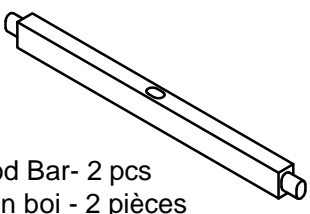
<p>2</p>  <p>Leg-1 pc Jambe-1 pièce</p>	<p>3</p>  <p>Leg-1 pc Jambe-1 pièce</p>	<p>4</p>  <p>Leg-1 pc Jambe-1 pièce</p>
<p>5</p>  <p>Leg-1 pc Jambe-1 pièce</p>	<p>6</p>  <p>wooden frame - 1 pc cadre en bois - 1 pièce</p>	<p>7</p>  <p>wooden frame - 1 pc cadre en bois - 1 pièce</p>
<p>12</p>  <p>Wood Bar- 1pc Barre en boi - 1 pièce</p>	<p>13</p>  <p>Leg-1 pc Jambe-1 pièce</p>	<p>16</p>  <p>Wood Bar- 1pc Barre en boi - 1 pièce</p>
<p>20</p>  <p>Leg-1 pc Jambe-1 pièce</p>	<p>21</p>  <p>Leg-1 pc Jambe-1 pièce</p>	<p>22</p>  <p>Wood Bar- 2 pcs Barre en boi - 2 pièces</p>
<p>27</p>  <p>Wood Bar- 2 pcs Barre en boi - 2 pièces</p>	<p>28</p>  <p>Wood Bar- 1pc Barre en boi - 1 pièce</p>	<p>29</p>  <p>Wood Bar- 1pc Barre en boi - 1 pièce</p>
<p>30</p>  <p>Wood Bar- 1pc Barre en boi - 1 pièce</p>	<p>31</p>  <p>Wood Bar- 1pc Barre en boi - 1 pièce</p>	<p>32</p>  <p>Wood Bar- 1pc Barre en boi - 1 pièce</p>
<p>33</p>  <p>Wood Bar- 2 pcs Barre en boi - 2 pièces</p>	<p>34</p>  <p>Wood Bar- 2 pcs Barre en boi - 2 pièces</p>	<p>35</p>  <p>Wood Bar- 2 pcs Barre en boi - 2 pièces</p>

Part List (Box 1)

Liste des pièces (Box 1)

39

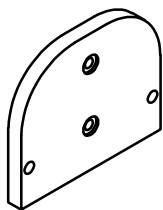

Panel - 4 pcs
Panneau - 4 pièces

45

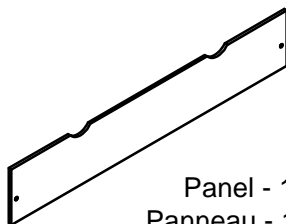

Panel - 1 pc
Panneau - 1 pièce

48

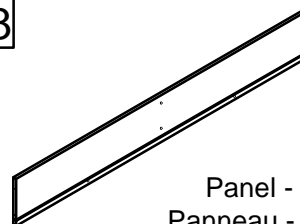

Panel - 1 pc
Panneau - 1 pièce



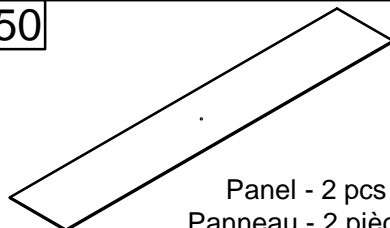





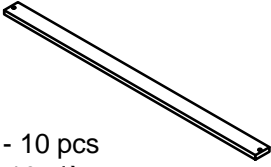
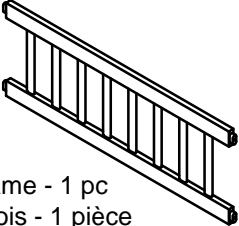
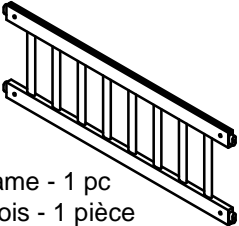

50

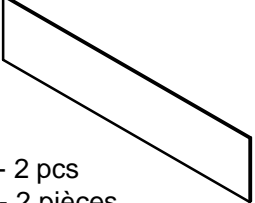

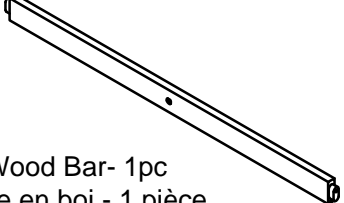
Panel - 2 pcs
Panneau - 2 pièces

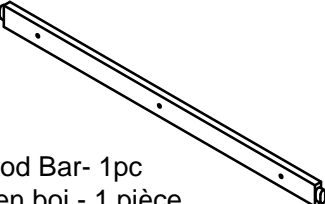
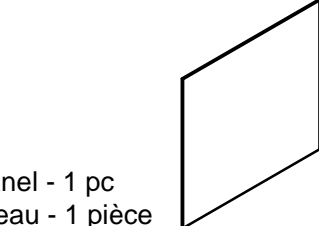
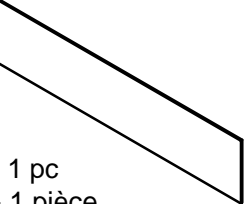
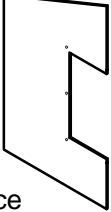
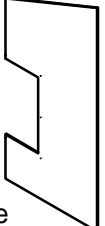
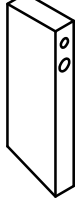
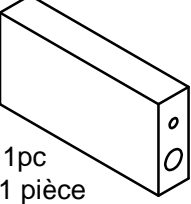
Part List & Hardware List (Box 2)

Liste des pièces et liste du matériel (Box 2)

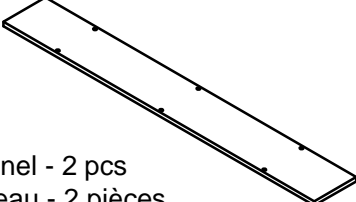
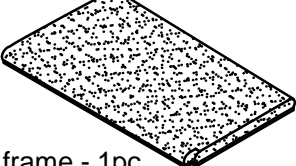
<p>1</p>  <p>Slats - 10 pcs Lattes - 10 pièces</p>	<p>8</p>  <p>wooden frame - 1 pc cadre en bois - 1 pièce</p>	<p>9</p>  <p>wooden frame - 1 pc cadre en bois - 1 pièce</p>
<p>10</p>  <p>Wood Bar- 2 pcs Barre en bois - 2 pièces</p>	<p>11</p>  <p>Panel - 2 pcs Panneau - 2 pièces</p>	<p>14</p>  <p>Wood Bar- 1pc Barre en bois - 1 pièce</p>
<p>15</p>  <p>Wood Bar- 1pc Barre en bois - 1 pièce</p>	<p>17</p>  <p>Wood Bar- 1pc Barre en bois - 1 pièce</p>	<p>18</p>  <p>Wood Bar- 1pc Barre en bois - 1 pièce</p>
<p>19</p>  <p>Wood Bar- 1pc Barre en bois - 1 pièce</p>	<p>23</p>  <p>Panel - 1 pc Panneau - 1 pièce</p>	<p>24</p>  <p>Panel - 1 pc Panneau - 1 pièce</p>
<p>25</p>  <p>Panel - 1 pc Panneau - 1 pièce</p>	<p>26</p>  <p>Panel - 1 pc Panneau - 1 pièce</p>	<p>36</p>  <p>Wood Bar- 1pc Barre en bois - 1 pièce</p>
<p>37</p>  <p>Wood Bar- 1pc Barre en bois - 1 pièce</p>	<p>38</p>  <p>Wood Bar- 1pc Barre en bois - 1 pièce</p>	<p>40</p>  <p>Wood Bar- 2 pcs Barre en bois - 2 pièces</p>
<p>41</p>  <p>Wood Bar- 2 pcs Barre en bois - 2 pièces</p>	<p>42</p>  <p>Panel - 2 pcs Panneau - 2 pièces</p>	<p>43</p>  <p>Mattress frame - 1pc Cadre de matelas - 1 pièce</p>

Part List & Hardware List (Box 2)

Liste des pièces et liste du matériel(Box 2)

44

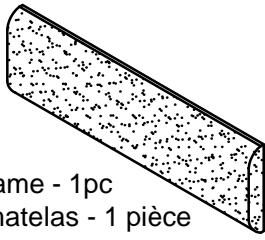

Mattress frame - 1pc
Cadre de matelas - 1 pièce

46

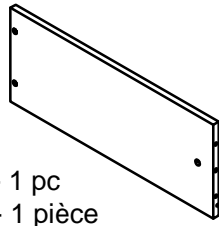

Panel - 1 pc
Panneau - 1 pièce

47

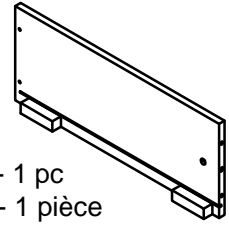

Panel - 1 pc
Panneau - 1 pièce

49

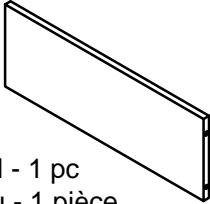











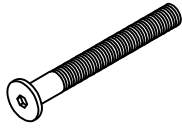
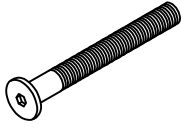
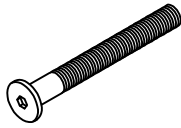
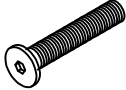

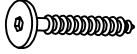
Panel - 1 pc
Panneau - 1 pièce

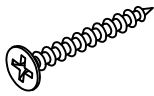
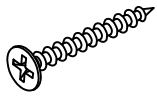
51

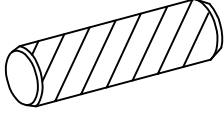
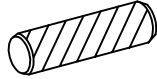

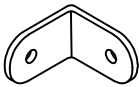
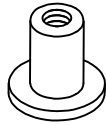
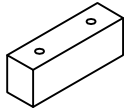
Wood Bar- 2 pcs
Barre en bois - 2 pièces

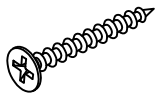
Hardware List (Box 2) Liste du matériel (Box 2)

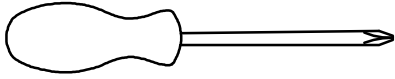
<p>A</p>  <p>Bolt Ø6 x 90 mm- 20 pcs Boulon Ø6 x 90 mm- 20 pièces</p>	<p>B</p>  <p>Bolt Ø6 x 70 mm-22 pcs Boulon Ø6 x 70 mm-22 pièces</p>	<p>C</p>  <p>Bolt Ø6 x 60 mm - 6 pcs Boulon Ø6 x 60 mm - 6 pièces</p>
<p>D</p>  <p>Bolt Ø6 x 30 mm - 28 pcs Boulon Ø6 x 30 mm - 28 pièces</p>	<p>E</p>  <p>Screws Ø6 x 70mm - 7 pcs Vis Ø6 x 70mm- 7 pièces</p>	<p>F</p>  <p>Screws Ø6 x 50 mm - 1 pcs Vis Ø6 x 50 mm- 1 pièces</p>
<p>G</p>  <p>Screws Ø6 x 35mm - 8 pcs Vis Ø6 x 35mm- 8 pièces</p>	<p>H</p>  <p>Wood Screws M4 x 30mm - 32 pcs Les vis à bois M4 x 30mm - 32 pièces</p>	<p>K</p>  <p>Wood Screws M3.5 x 12mm - 6 pcs Les vis à bois M3.5 x 12mm - 6 pièces</p>
<p>L</p>  <p>Wood Screws M4 x 15mm - 18 pcs Les vis à bois M4 x 15mm - 18 pièces</p>	<p>M</p>  <p>Wood dowel Ø10 x 40mm - 18 pcs Cheville en bois Ø10 x 40mm - 18 pièces</p>	<p>N</p>  <p>Wood dowel Ø6 x 25mm - 6 pcs Cheville en bois Ø6 x 25mm - 6 pièces</p>
<p>P</p>  <p>Ø6 x 13 mm Horizontal-Hole bolts - 46 pcs Boulons à trou horizontal - 46 pièces</p>	<p>Q</p>  <p>Angle Metal 17*17*1 - 3 pcs Angle métallique 17*17*1- 3 pièces</p>	<p>R</p>  <p>Ø6 x 15 mm - 2 pcs Ø6 x 15 mm - 2 pièces</p>
<p>S</p>  <p>Drawer lock- 2 pcs Serrure de tiroir - 2 pièces</p>	<p>Y</p>  <p>Wheels (H=28MM)= 4 PCS Roues (H=28MM)= 4 pièces</p>	<p>J</p>  <p>Wood Screws M4 x 25mm - 4 pcs Les vis à bois M4 x 25mm - 4 pièces</p>
<p>V</p>  <p>Allen Key- 1 pc Clé Allen- 1 pièce</p>	 <p>Assembly Tools Required (Not Included) Outils d'assemblage requis (non inclus)</p>	

STEP 1-1:

Étape 1-1:

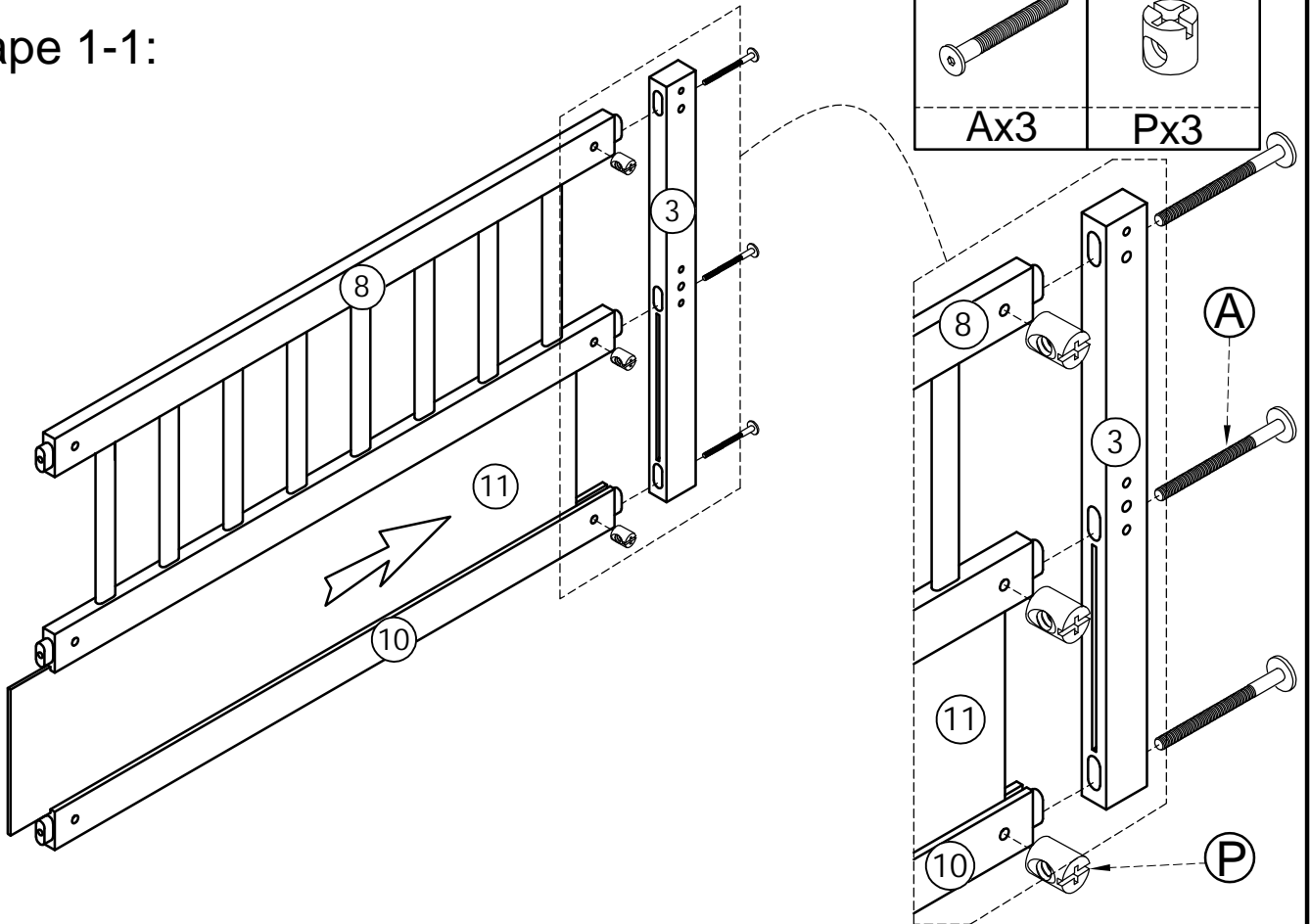

STEP 1-2:

Étape 1-2:

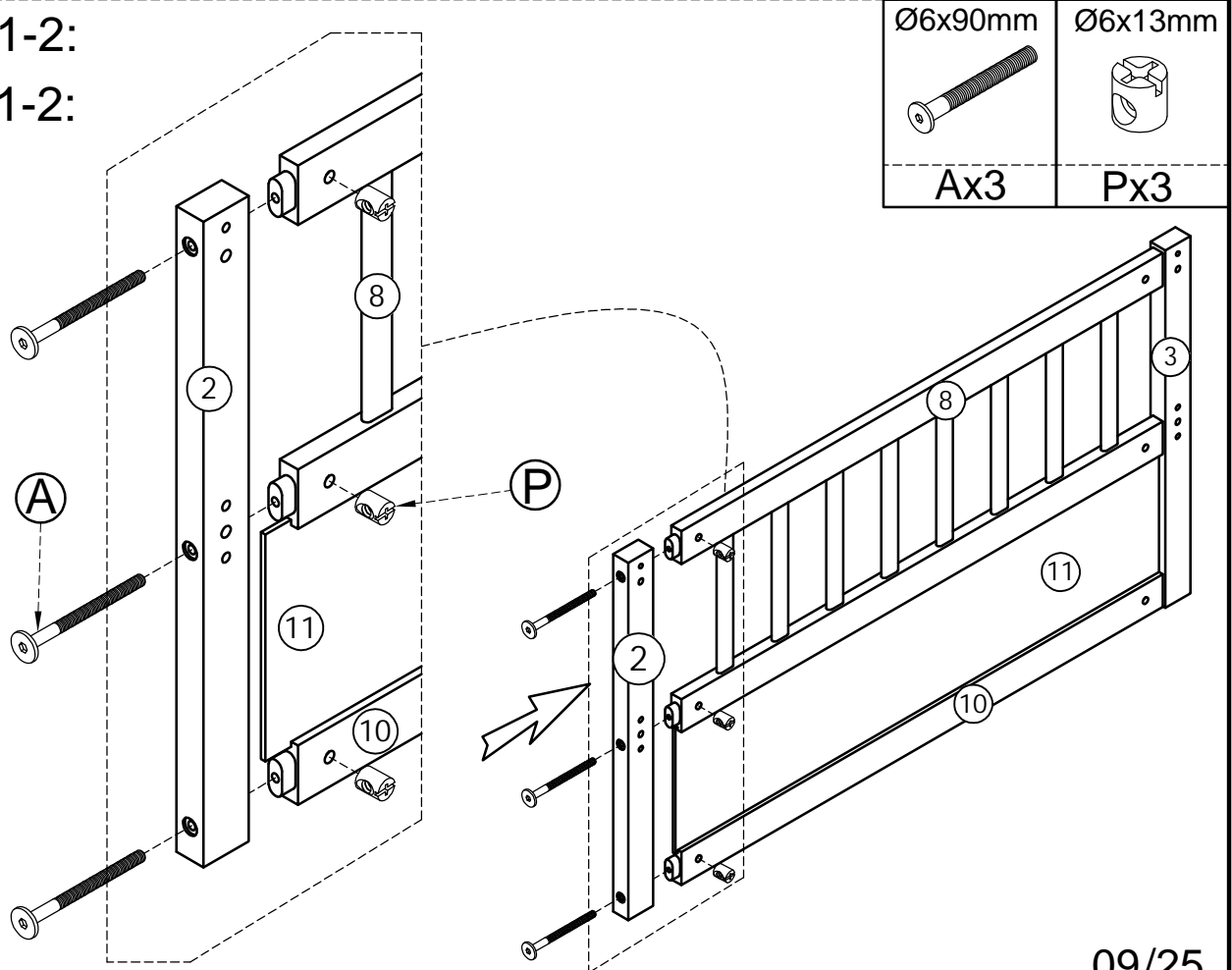

STEP 2-1:

Étape 2-1:

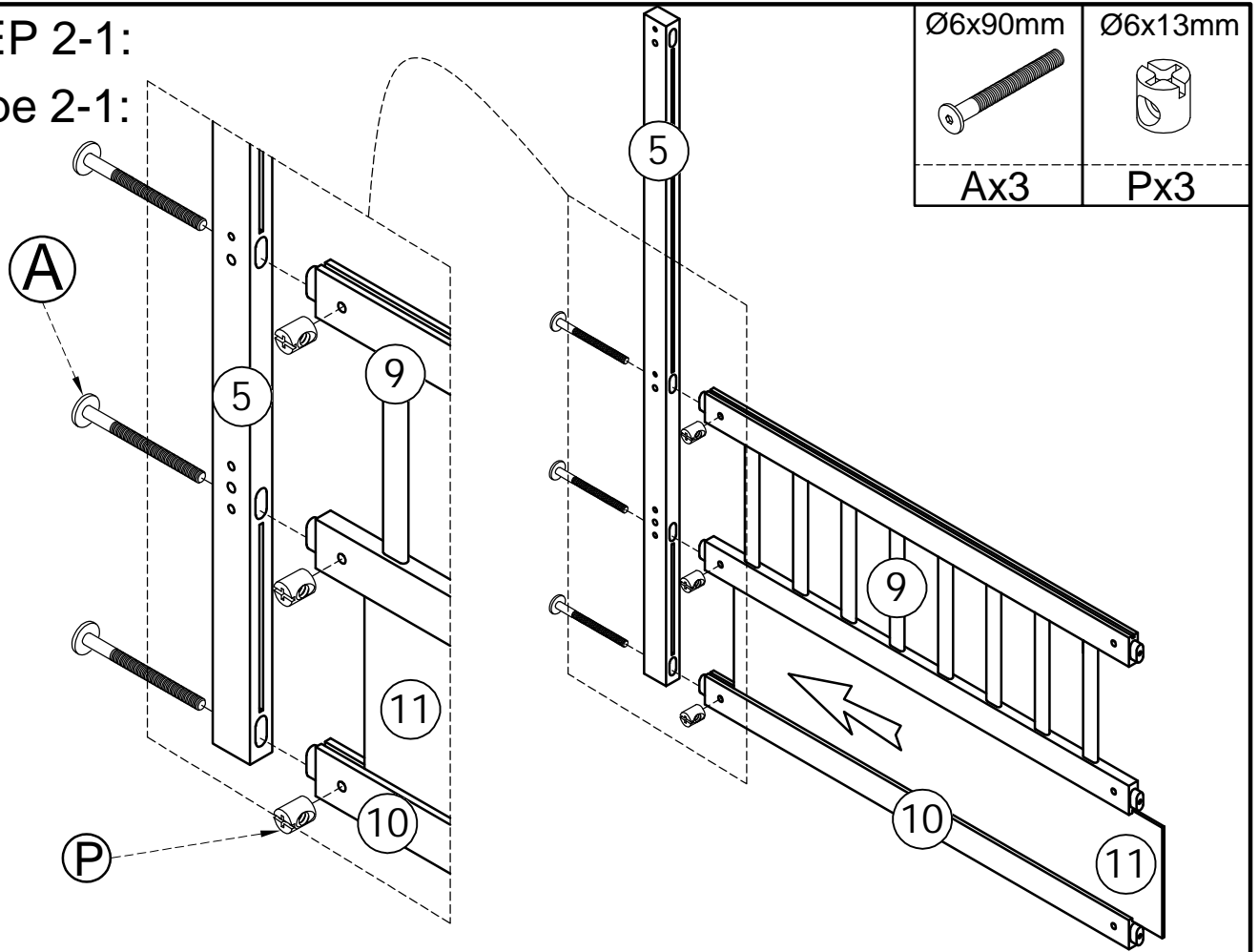

STEP 2-2:

Étape 2-2:

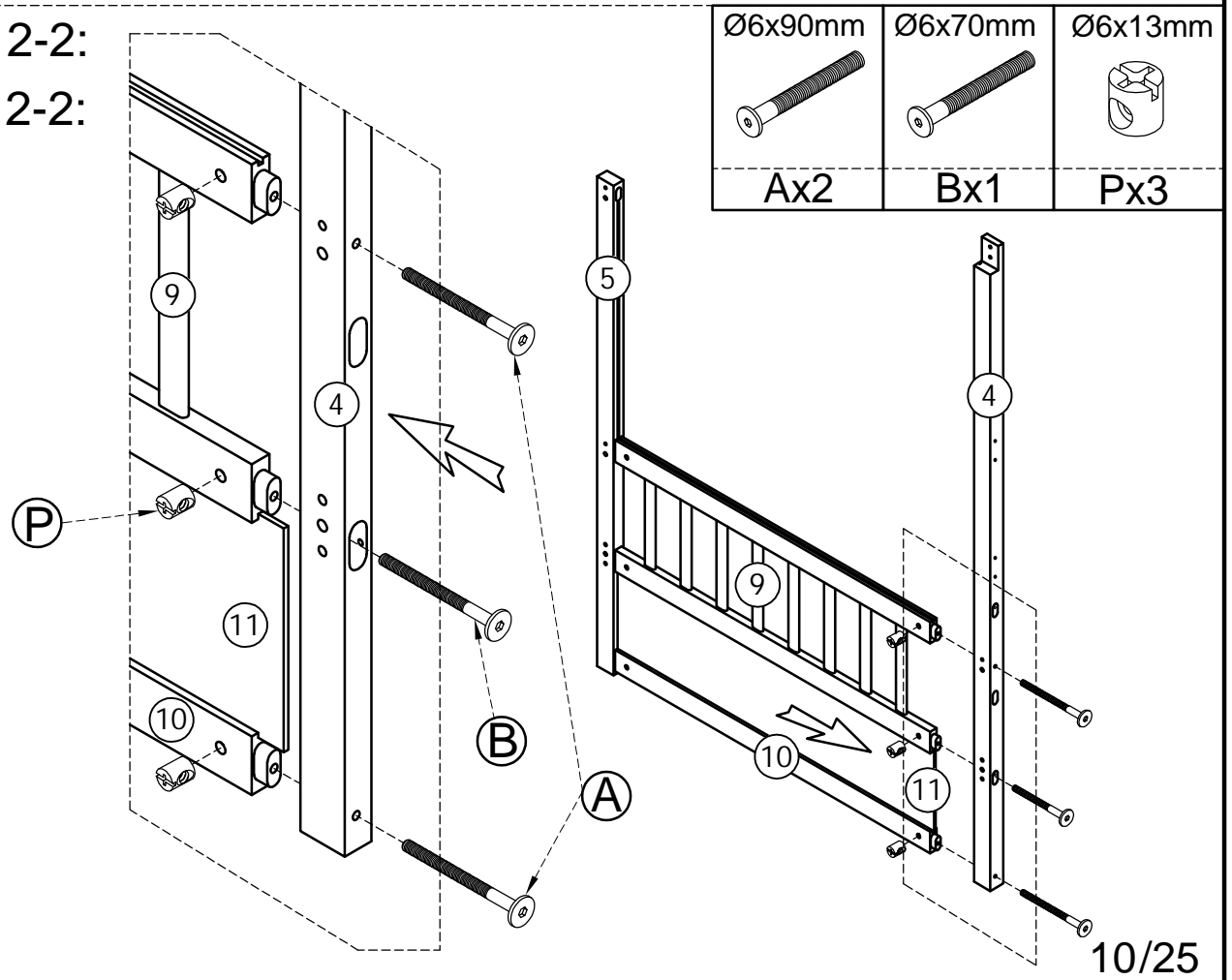

STEP 3:

Étape 3:

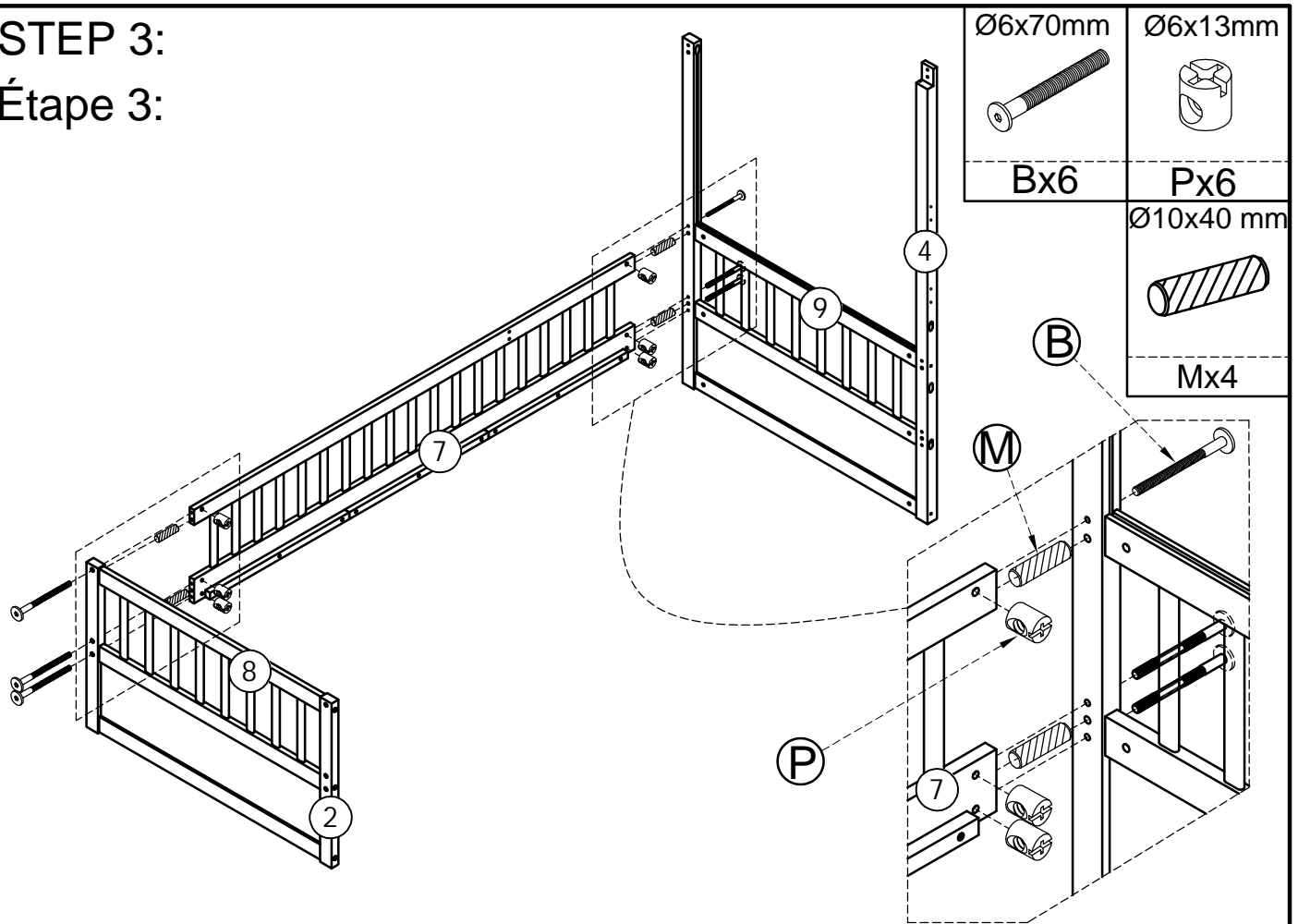

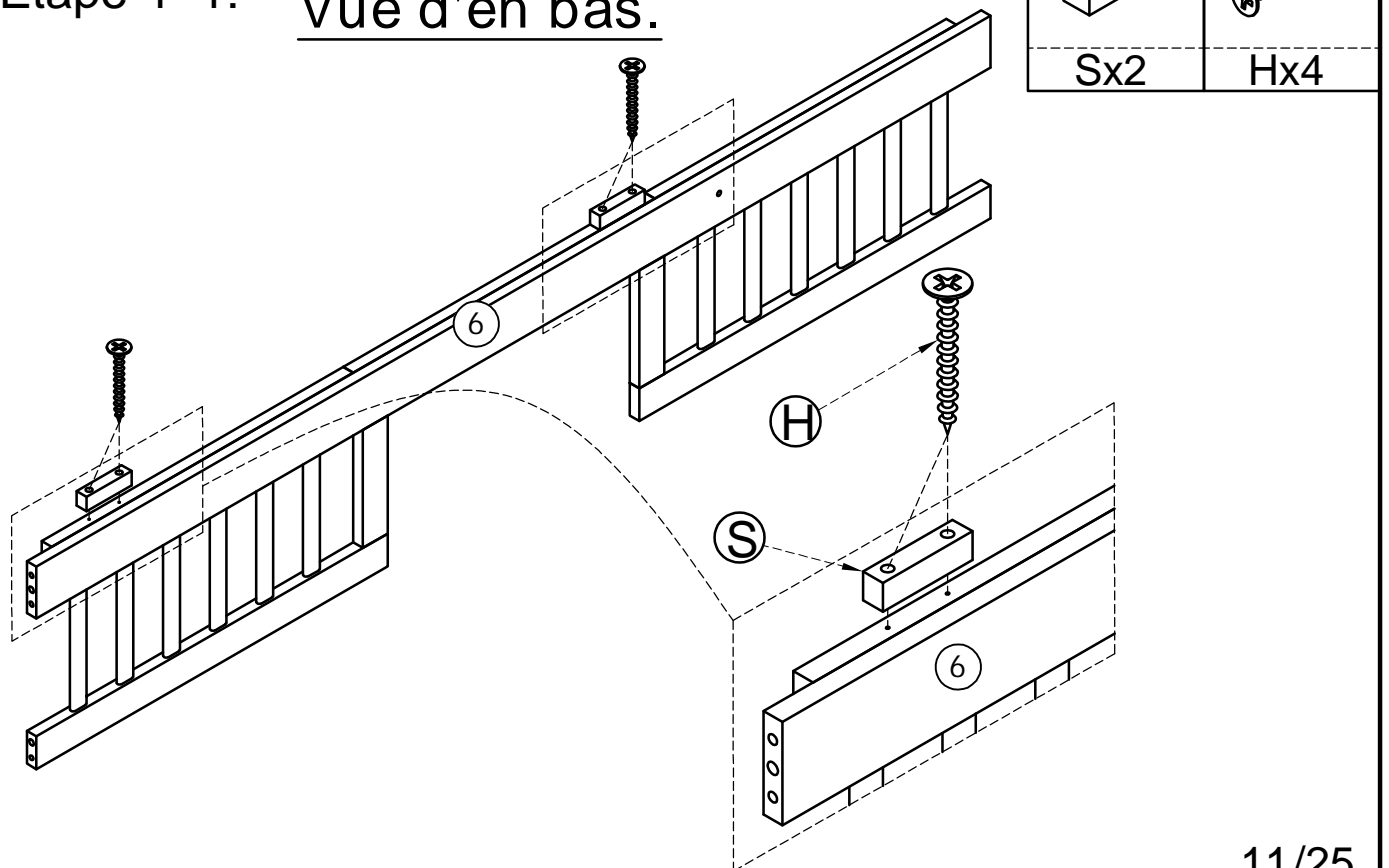

STEP 4 -1: View from below.

Étape 4 -1: Vue d'en bas.

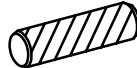
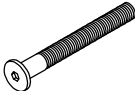

STEP 4 -2:
Étape 4 -2:

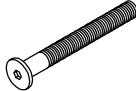
$\varnothing 10 \times 40 \text{ mm}$  Mx4	$\varnothing 6 \times 70 \text{ mm}$  Bx3	$\varnothing 6 \times 13 \text{ mm}$  Px6
$\varnothing 6 \times 90 \text{ mm}$  Ax3		

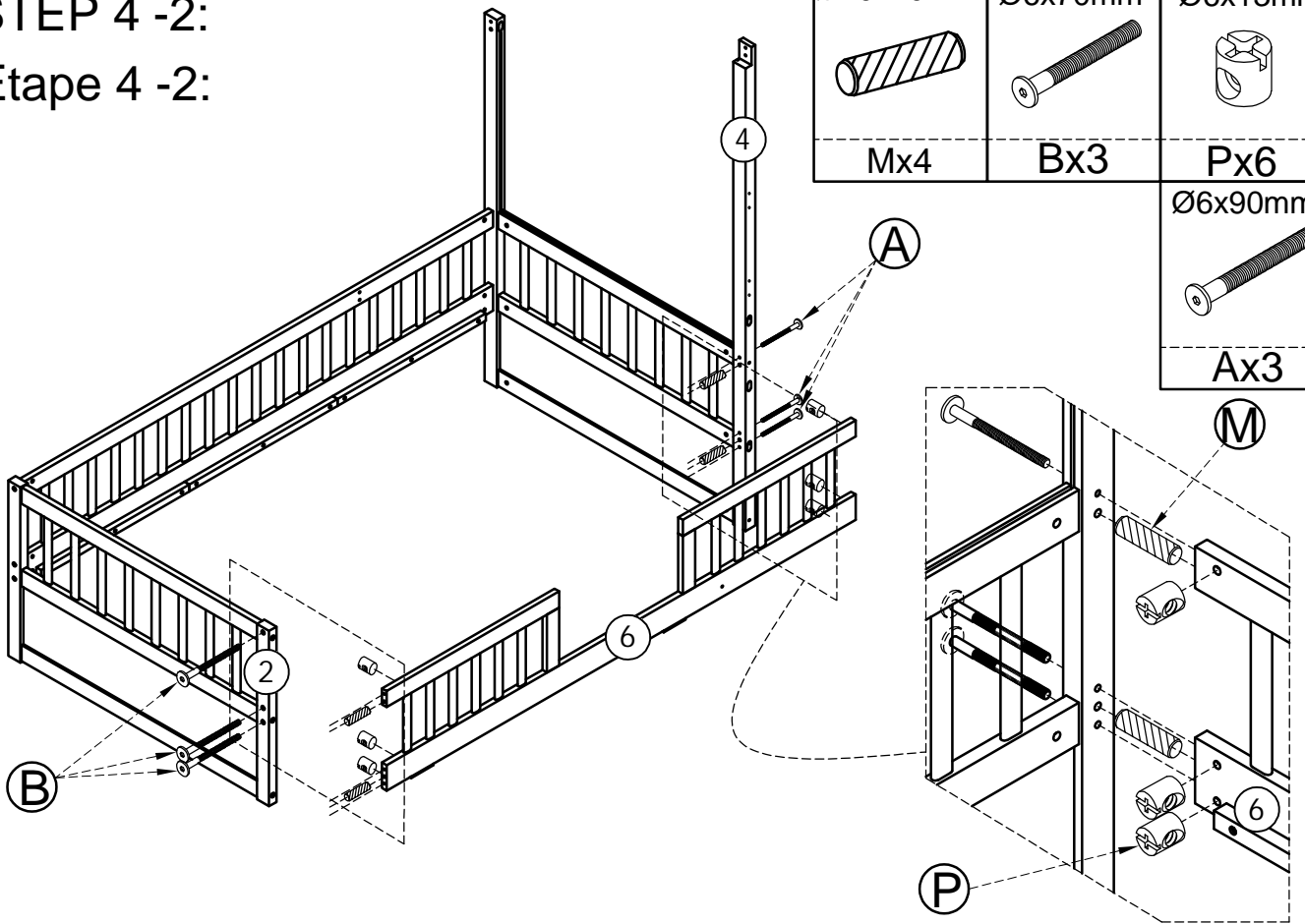

STEP 5:
Étape 5:

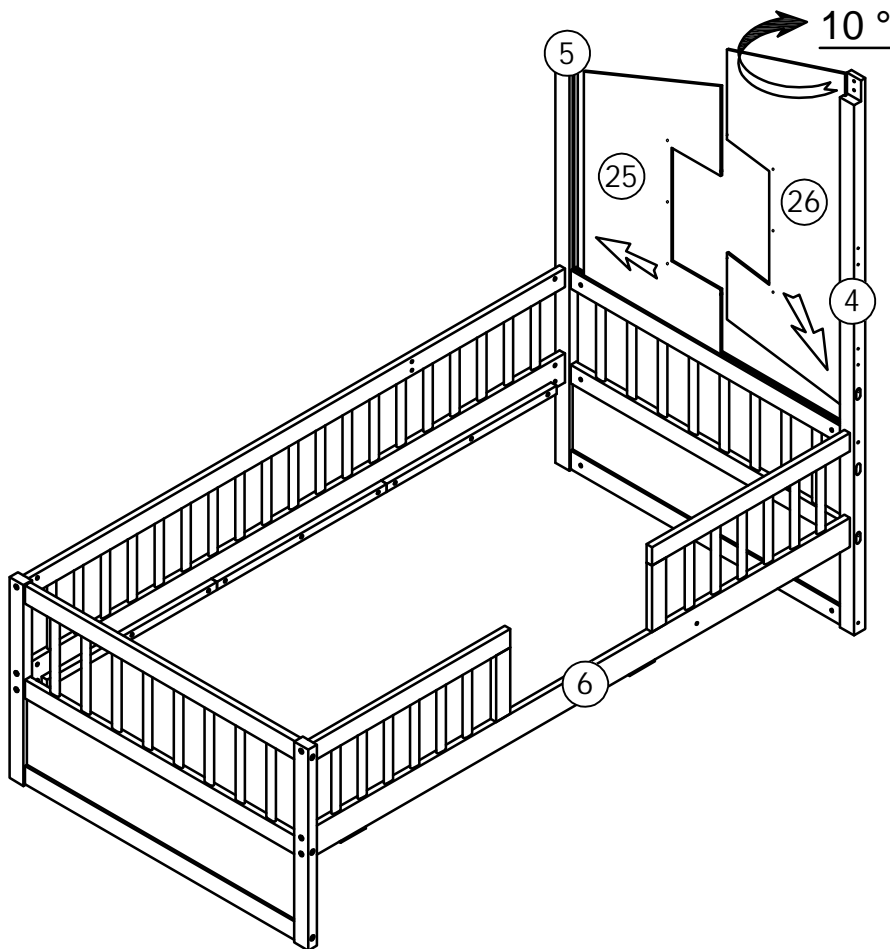

STEP 6 -1:

Étape 6 -1:

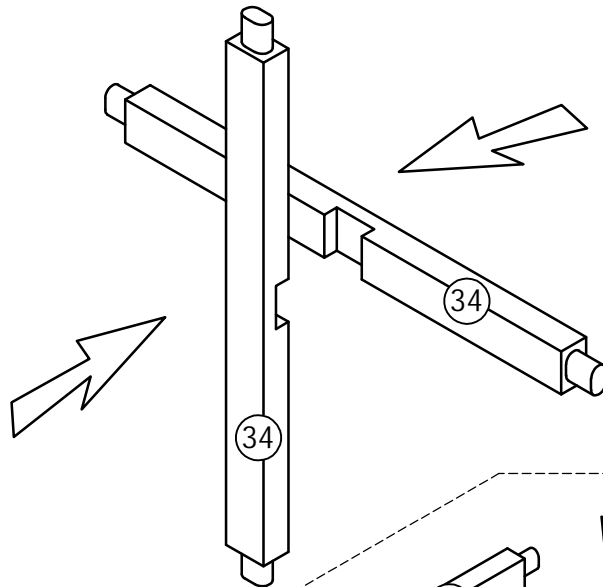

STEP 6 -2:

Étape 6 -2:

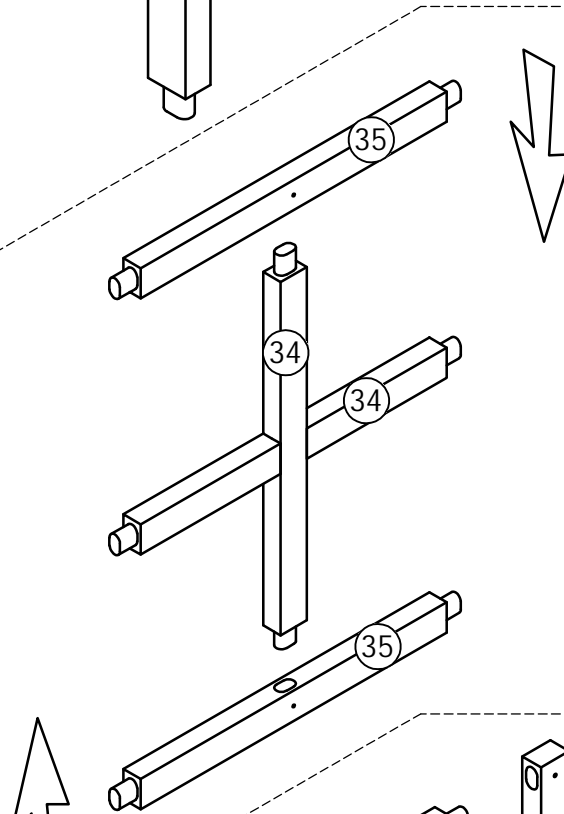

STEP 6 -3:

Étape 6 -3:

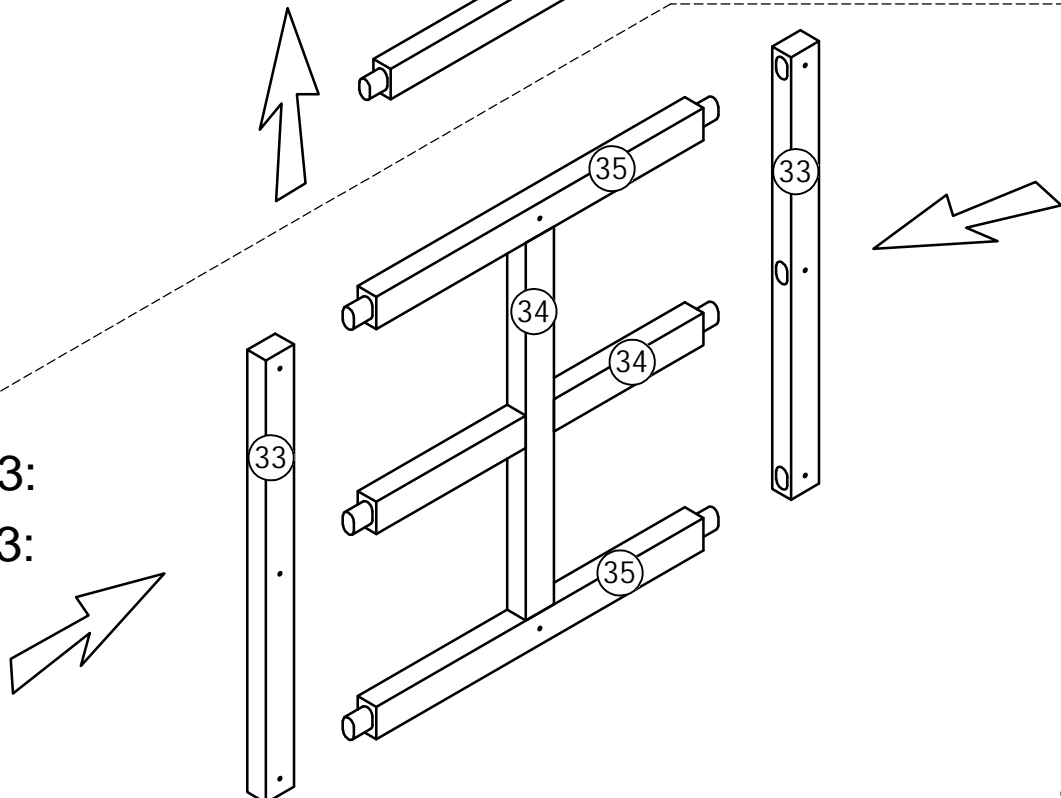

STEP 7:
Étape 7:

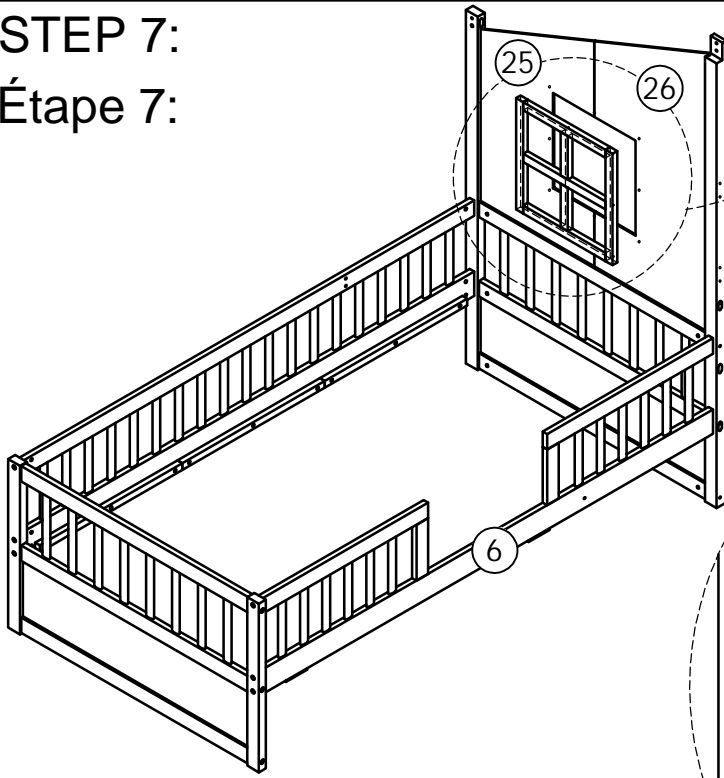

M4x15mm



Lx8

View from behind.
Vue de derrière.

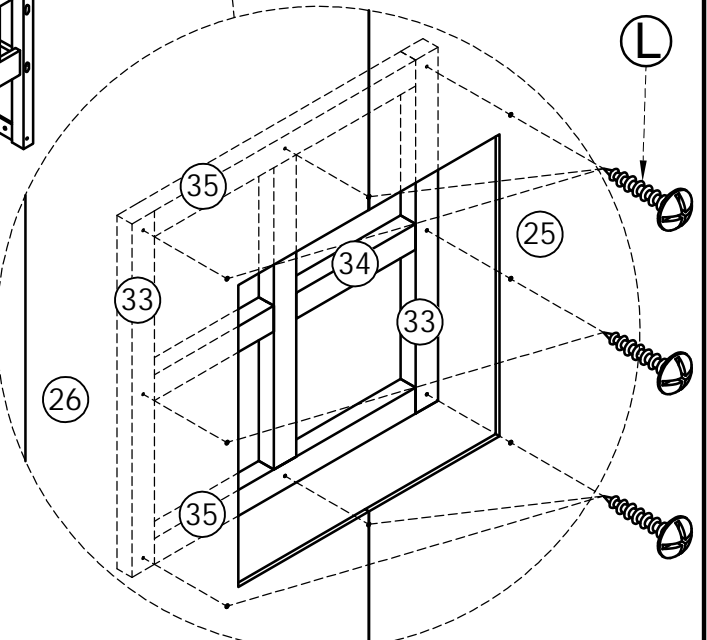

STEP 8:
Étape 8:

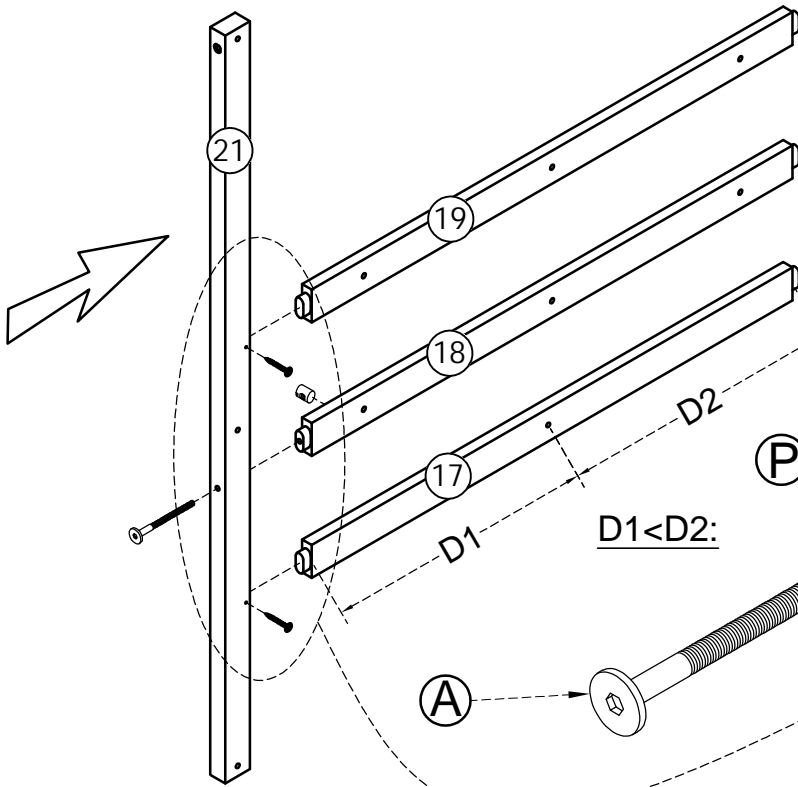

Ø6x90mm

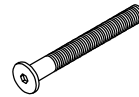

Ax1

Ø6x13mm



Px1

M4x25mm



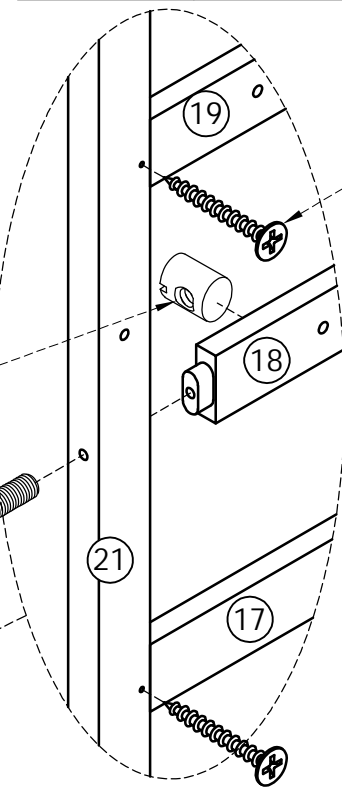

Jx2



STEP 9:

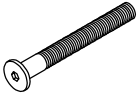

Étape 9:

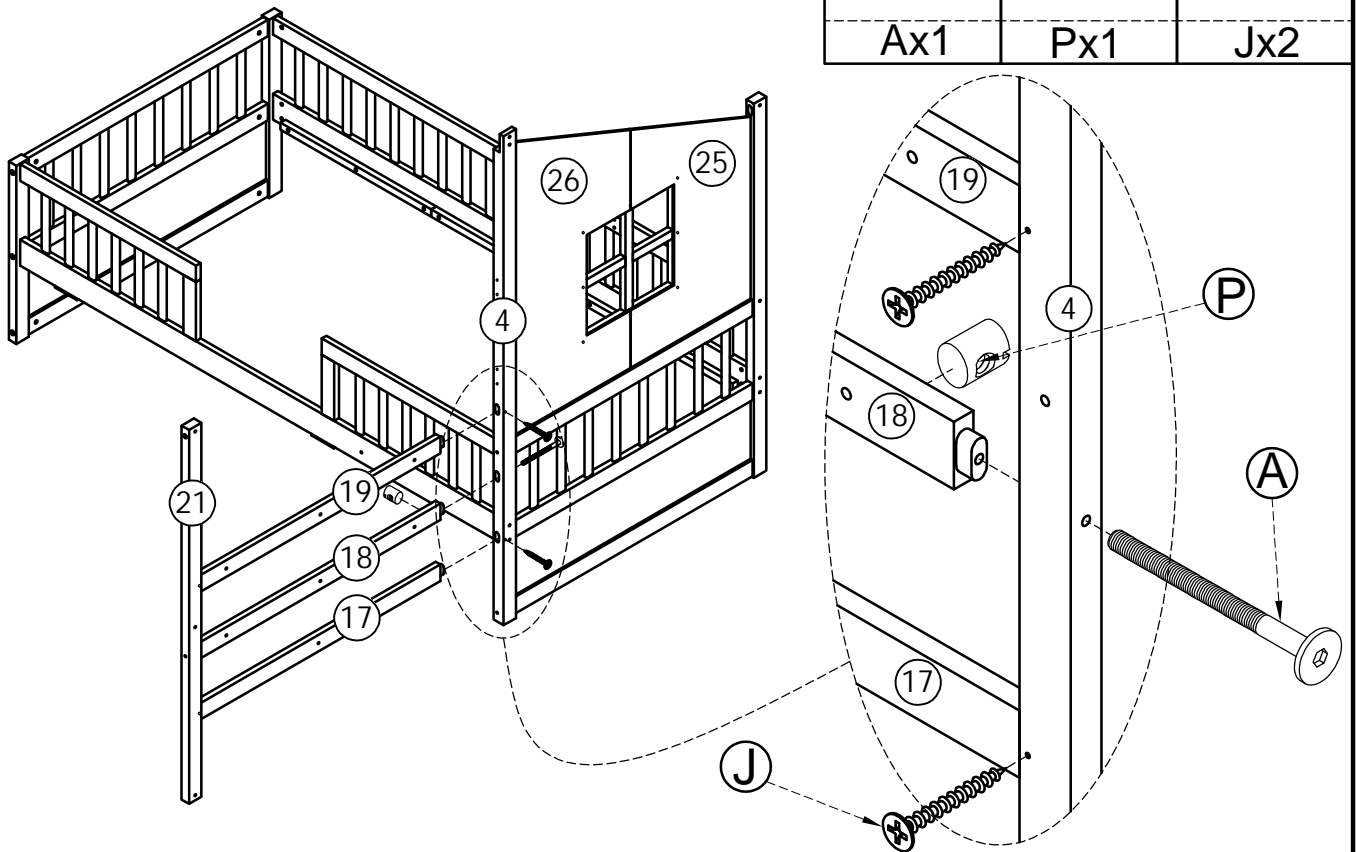
Ø6x90mm 	Ø6x13mm 	M4x25mm 
Ax1	Px1	Jx2

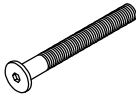

STEP 10:

Étape 10:

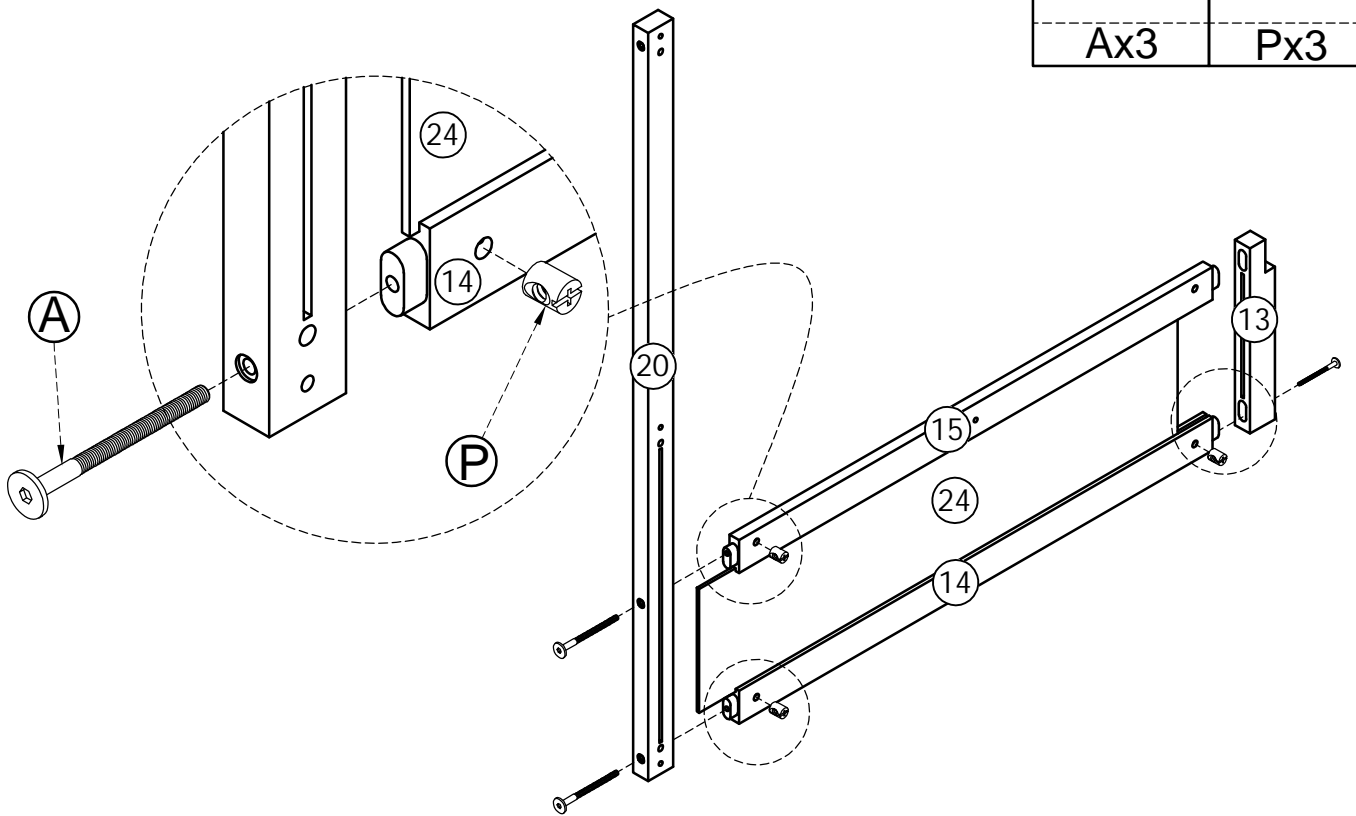

Ø6x90mm 	Ø6x13mm 
Ax3	Px3

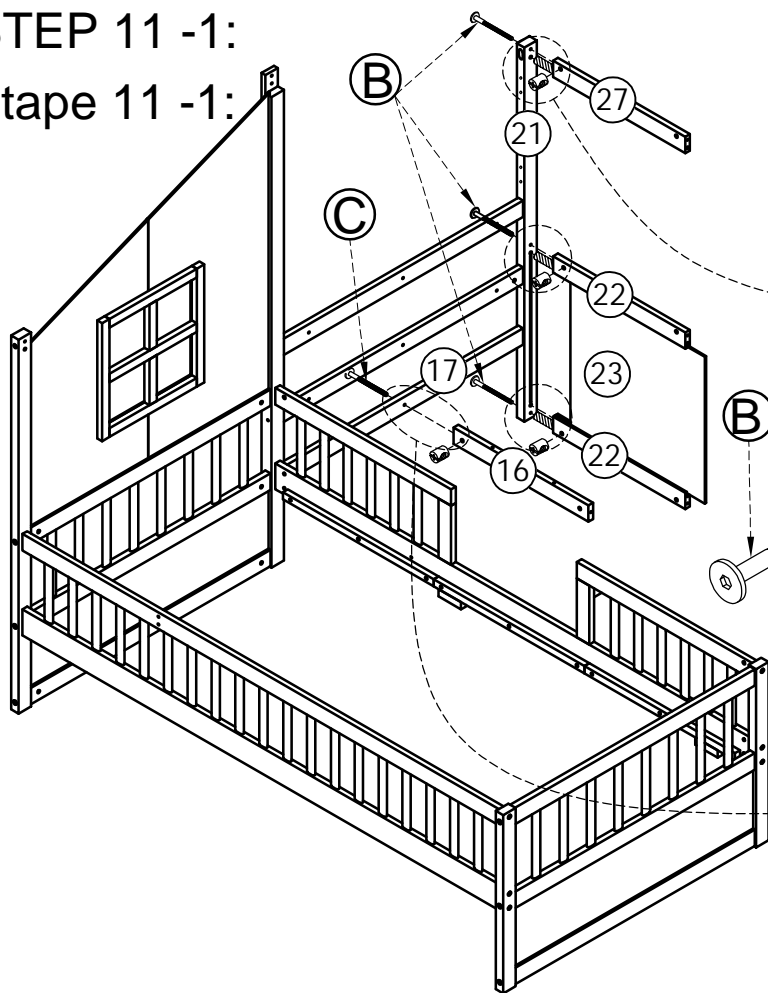

STEP 11 -1:

Étape 11 -1:

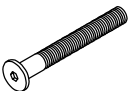
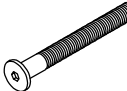

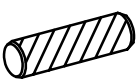

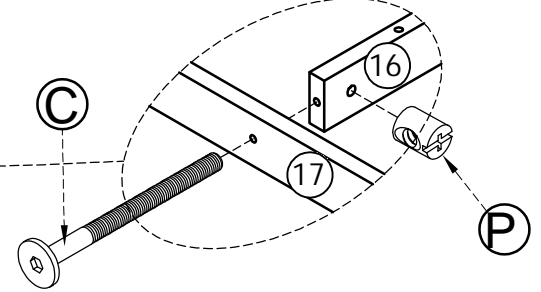
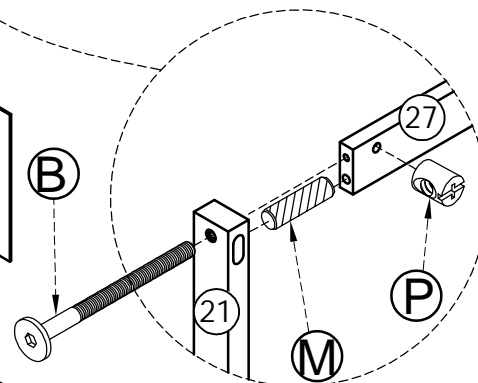
$\varnothing 6 \times 70 \text{ mm}$  Bx3	$\varnothing 6 \times 60 \text{ mm}$  Cx1	$\varnothing 6 \times 13 \text{ mm}$  Px4
$\varnothing 10 \times 40 \text{ mm}$  Mx3		

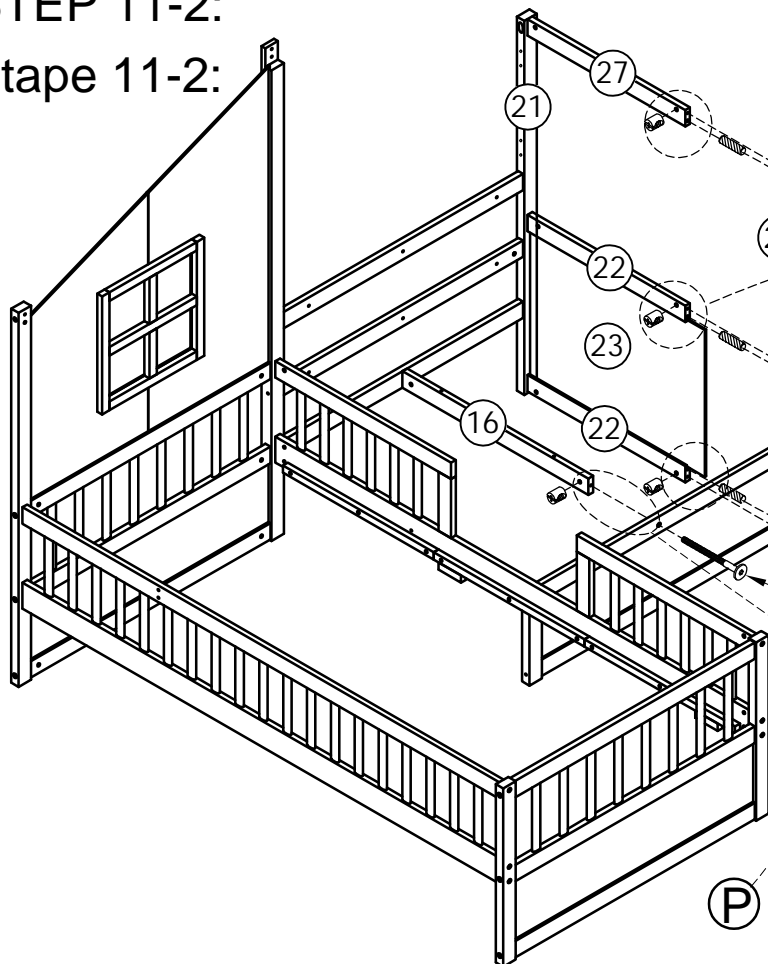

STEP 11-2:

Étape 11-2:

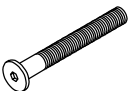
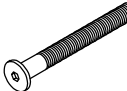

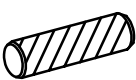
$\varnothing 6 \times 70 \text{ mm}$  Bx3	$\varnothing 6 \times 60 \text{ mm}$  Cx1	$\varnothing 6 \times 13 \text{ mm}$  Px4
$\varnothing 10 \times 40 \text{ mm}$  Mx3		

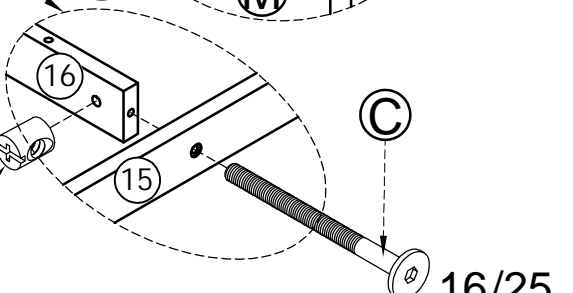
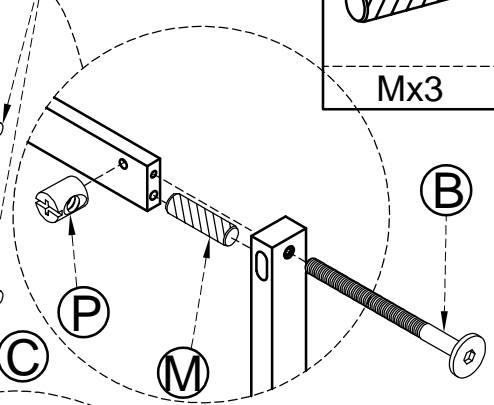

STEP 12:

Étape 12:

Ø6x90mm

Ø6x13mm

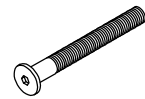

Ax1

Px1

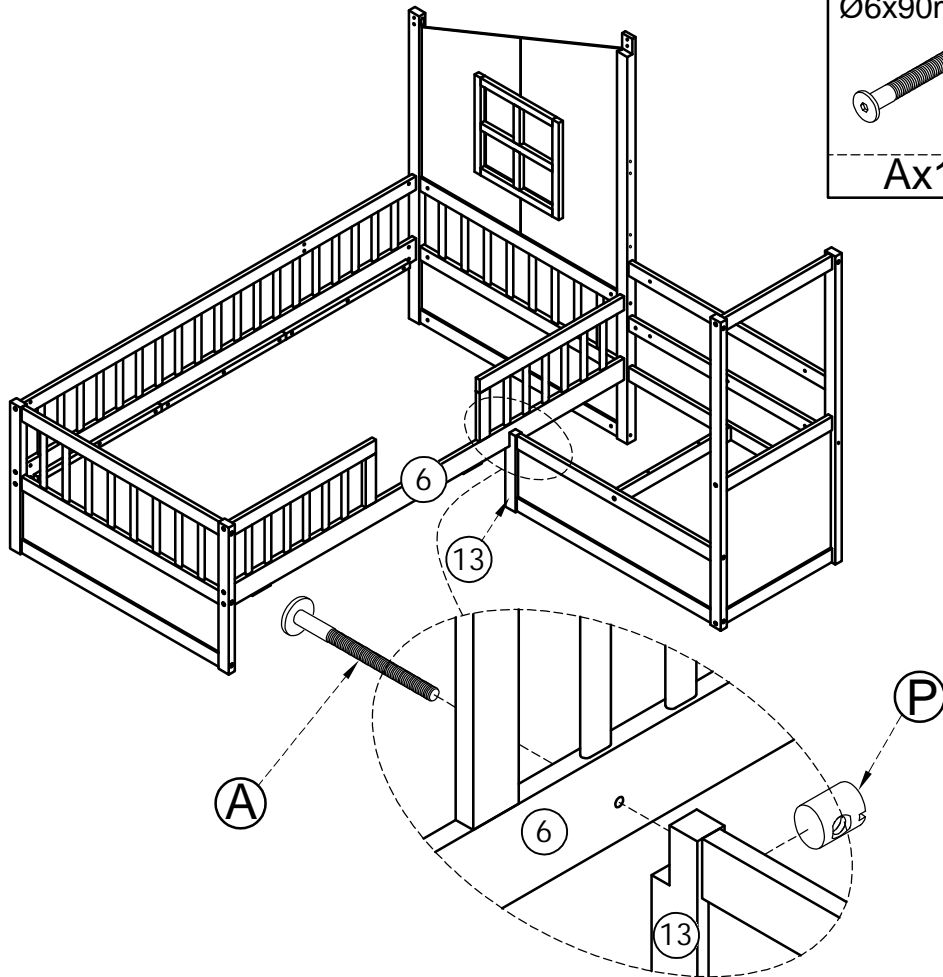

STEP 13 - 1:

Étape 13 - 1:

Ø6x30mm



Dx20

x2

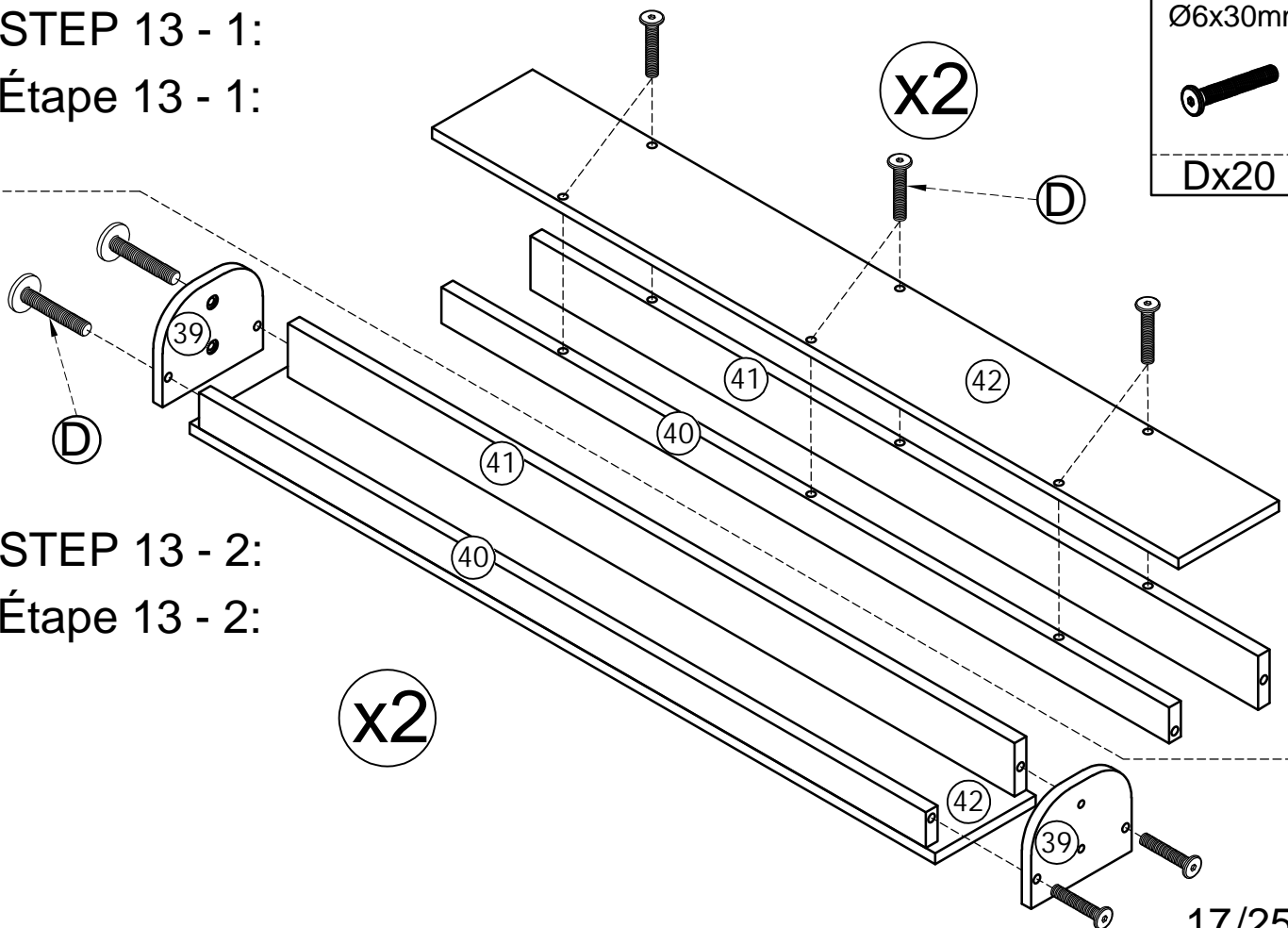

STEP 13 - 2:

Étape 13 - 2:

x2

STEP 13 -3:

Étape 13 -3:

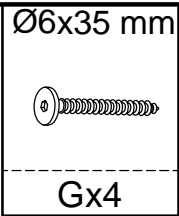

Balance the parts and
press down gently.
Équilibrez les pièces et
appuyez doucement.

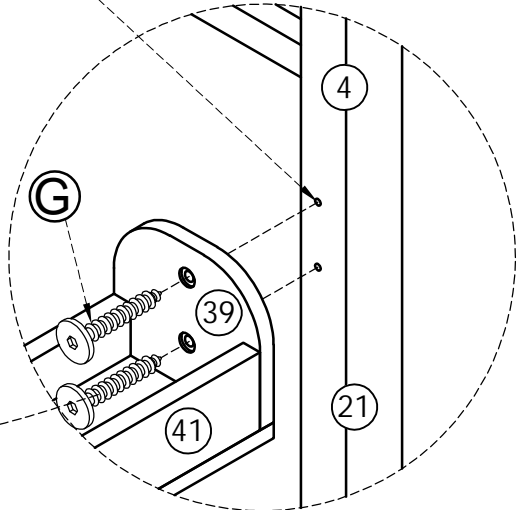
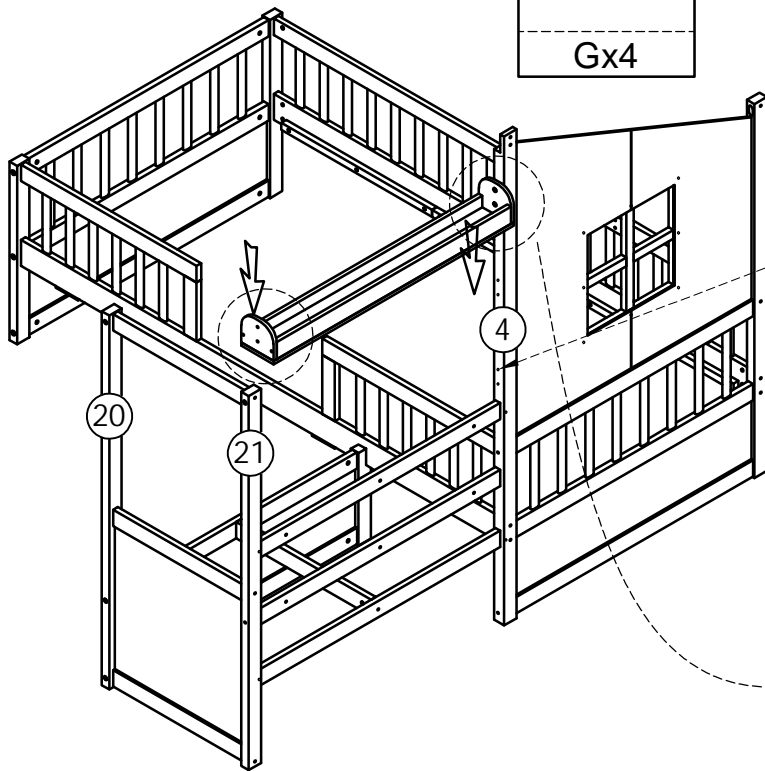

STEP 13 -4:

Étape 13 -4:

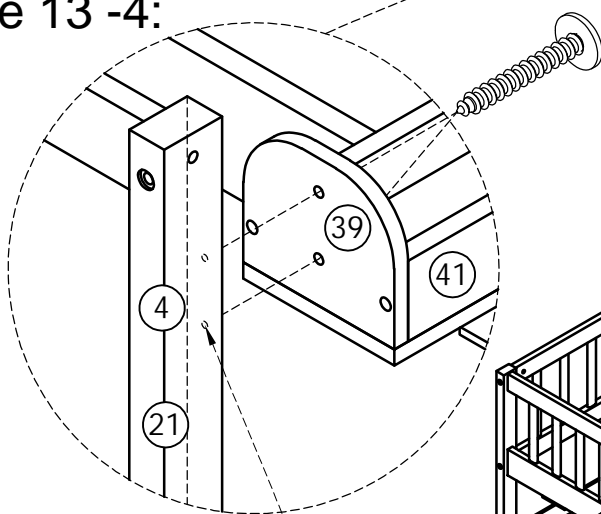
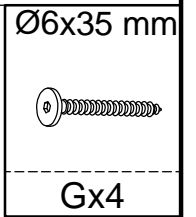

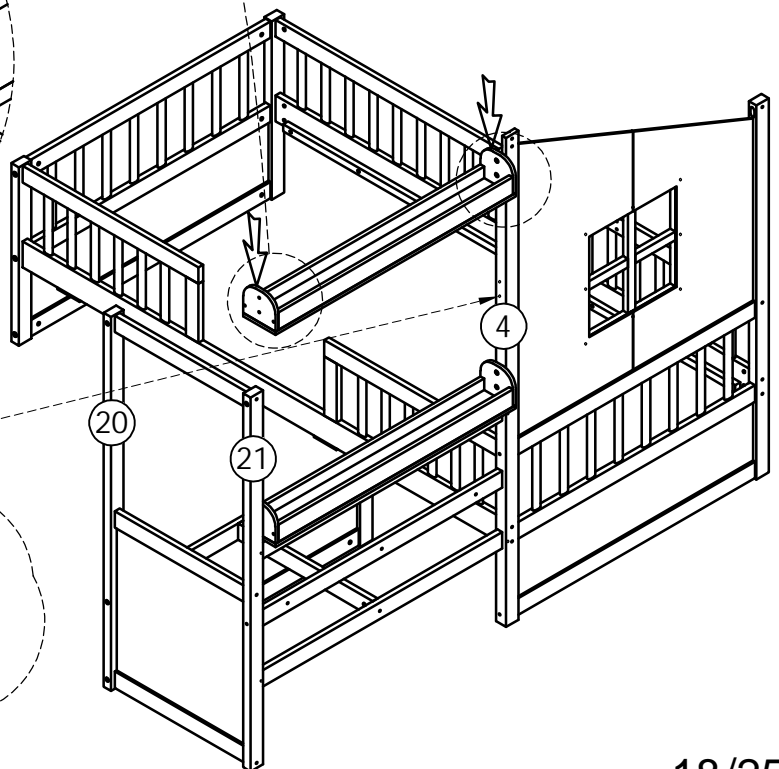

Balance the parts and
press down gently.
Équilibrez les pièces et
appuyez doucement.



STEP 14:

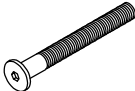

Étape 14:

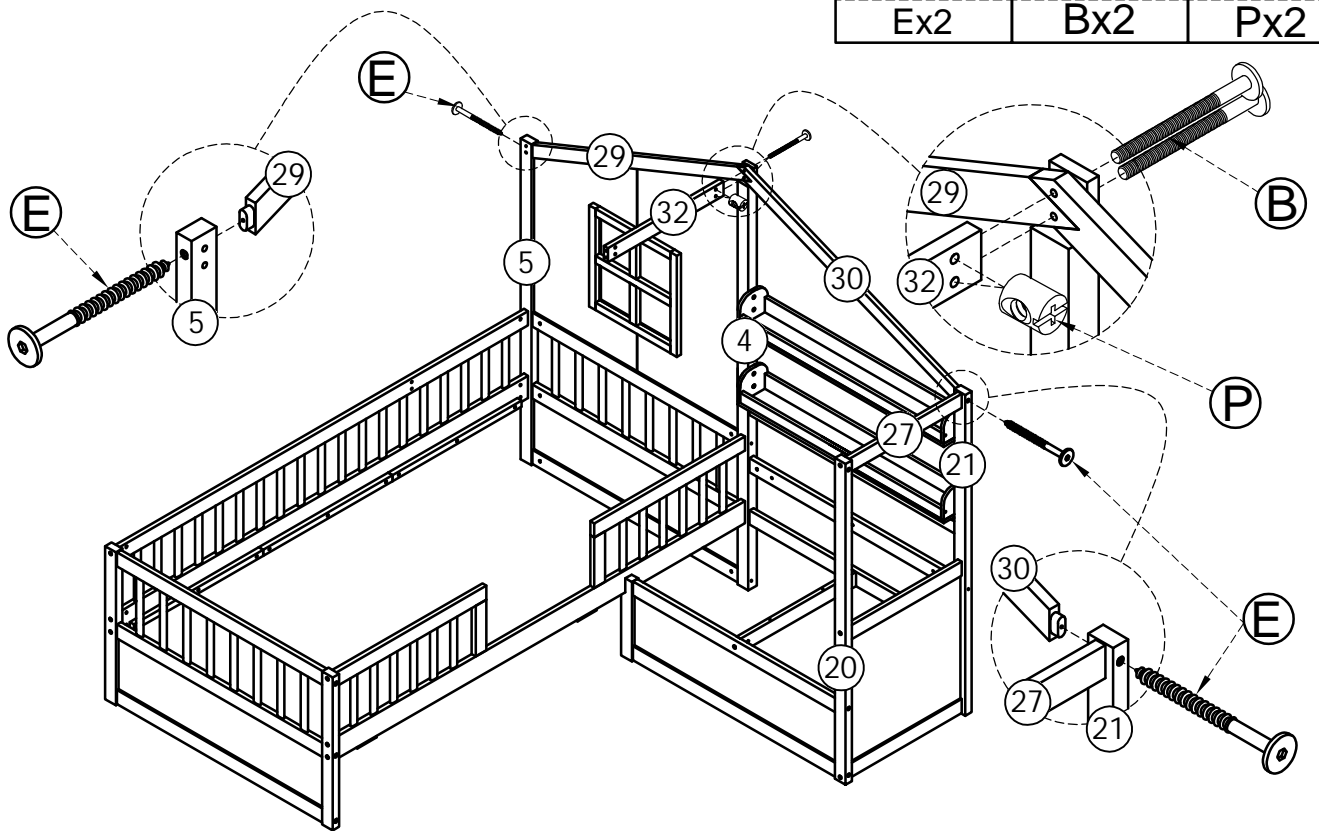
Ø6x70 mm	Ø6x70mm	Ø6x13mm
		
Ex2	Bx2	Px2

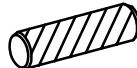
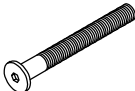

STEP 15:

Étape 15:

Ø10x40 mm	Ø6x70mm	Ø6x13mm
		
Mx1	Bx1	Px1

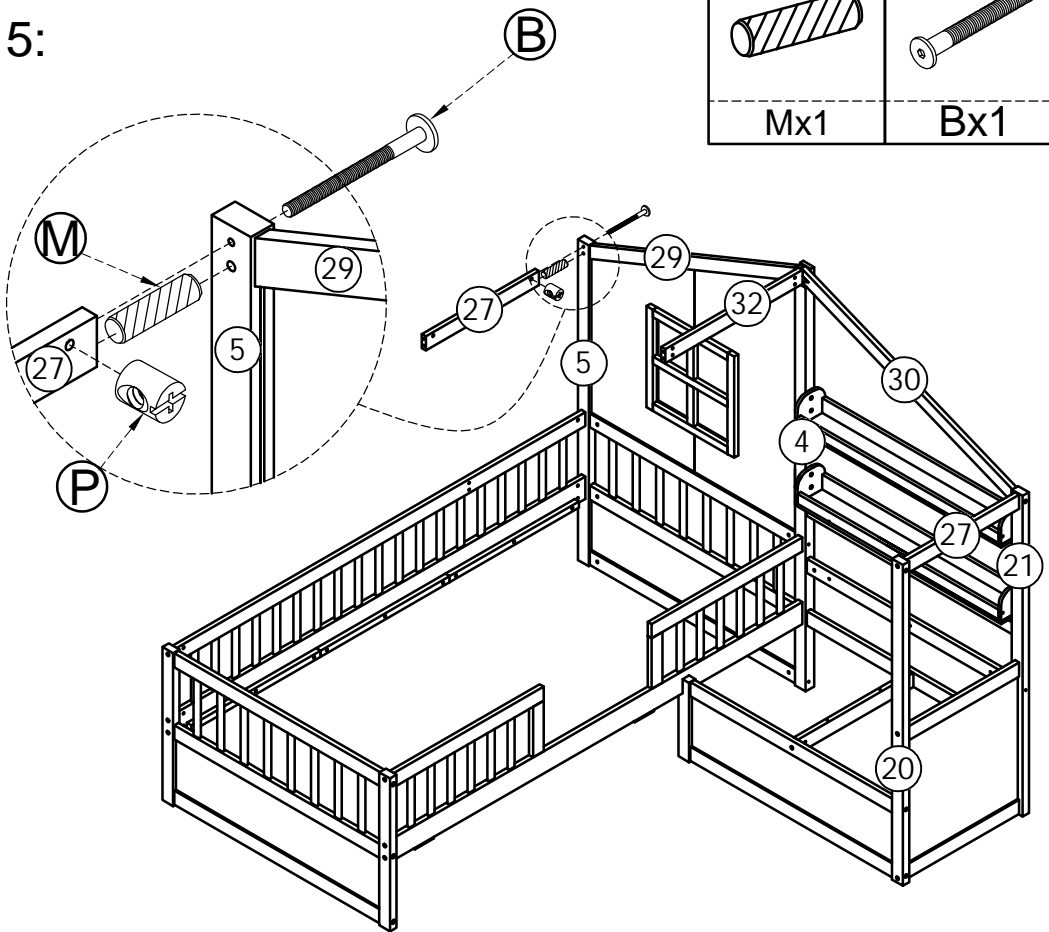

STEP 16:

Étape 16:

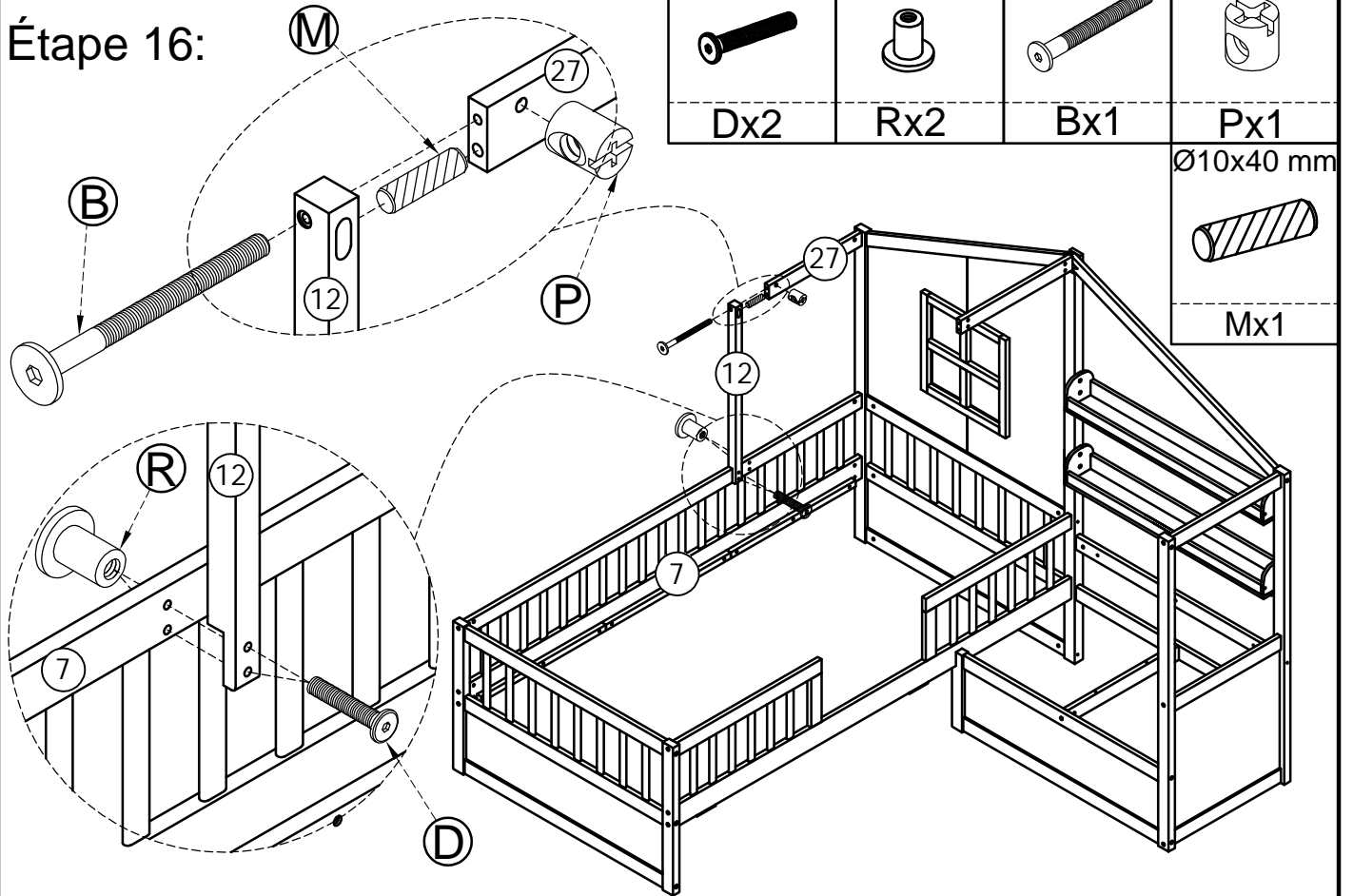

STEP 17:

Étape 17:

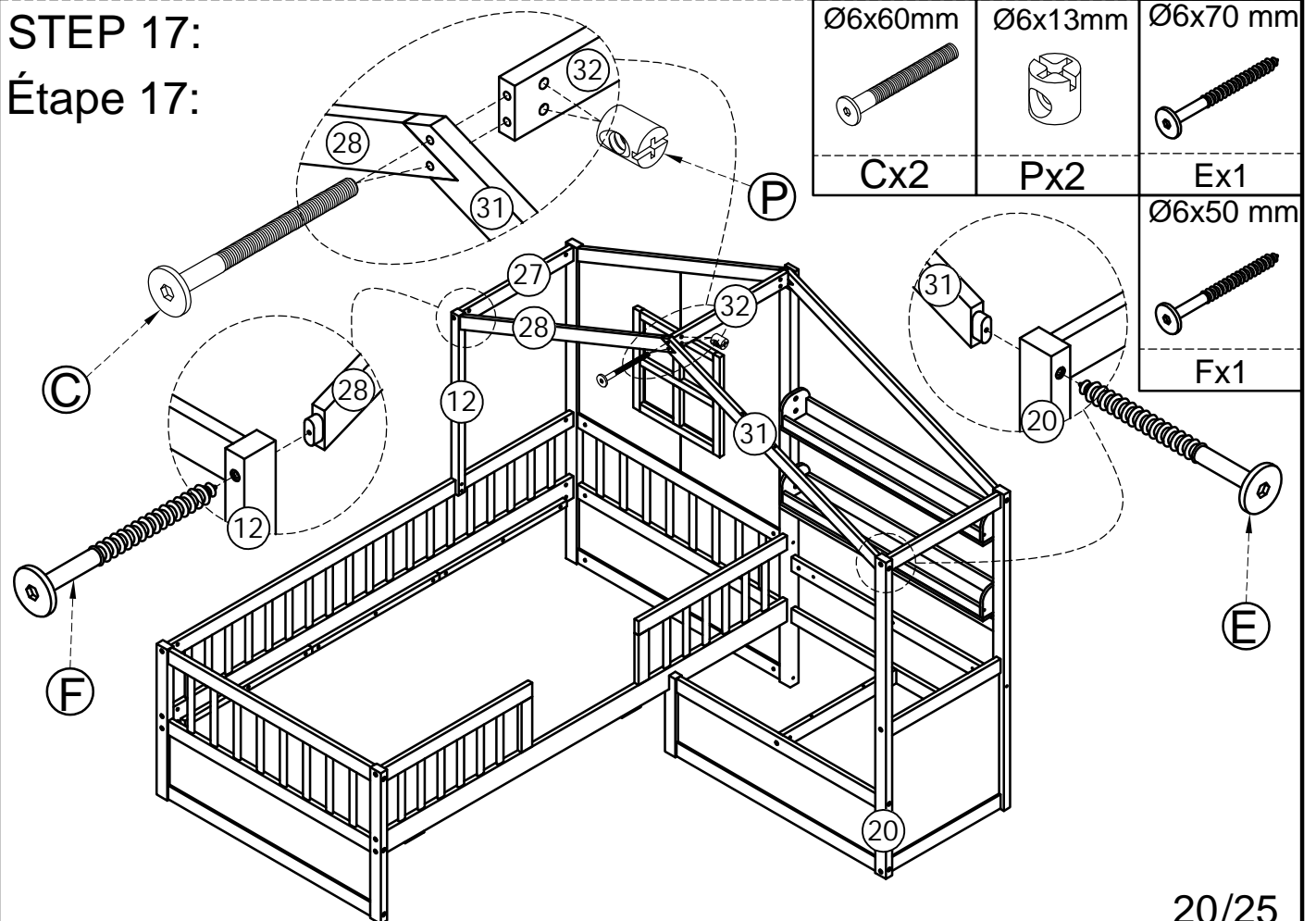

STEP 18 - 1:

Étape 18 - 1:

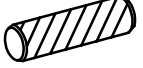
Ø6x70 mm	Ø10x40 mm
	
Ex2	Mx2

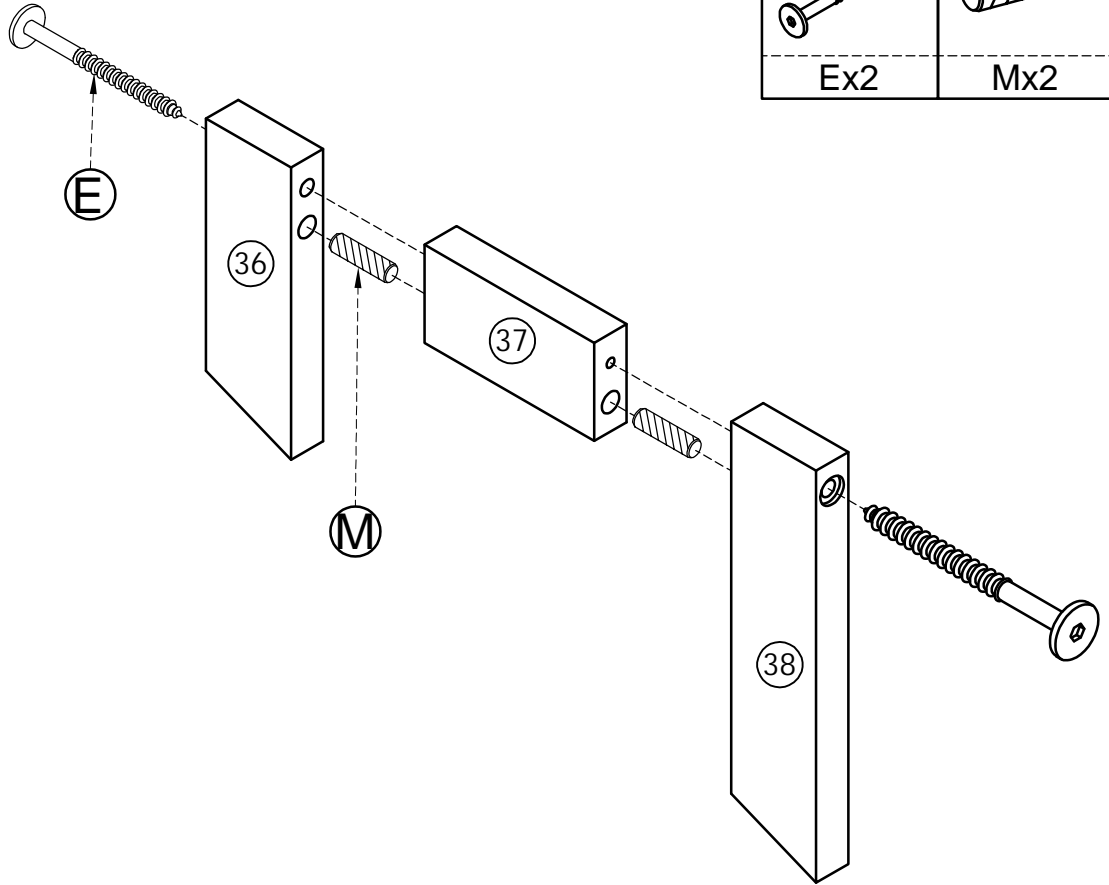

STEP 18 - 2:

Étape 18 - 2:

Ø6x70 mm

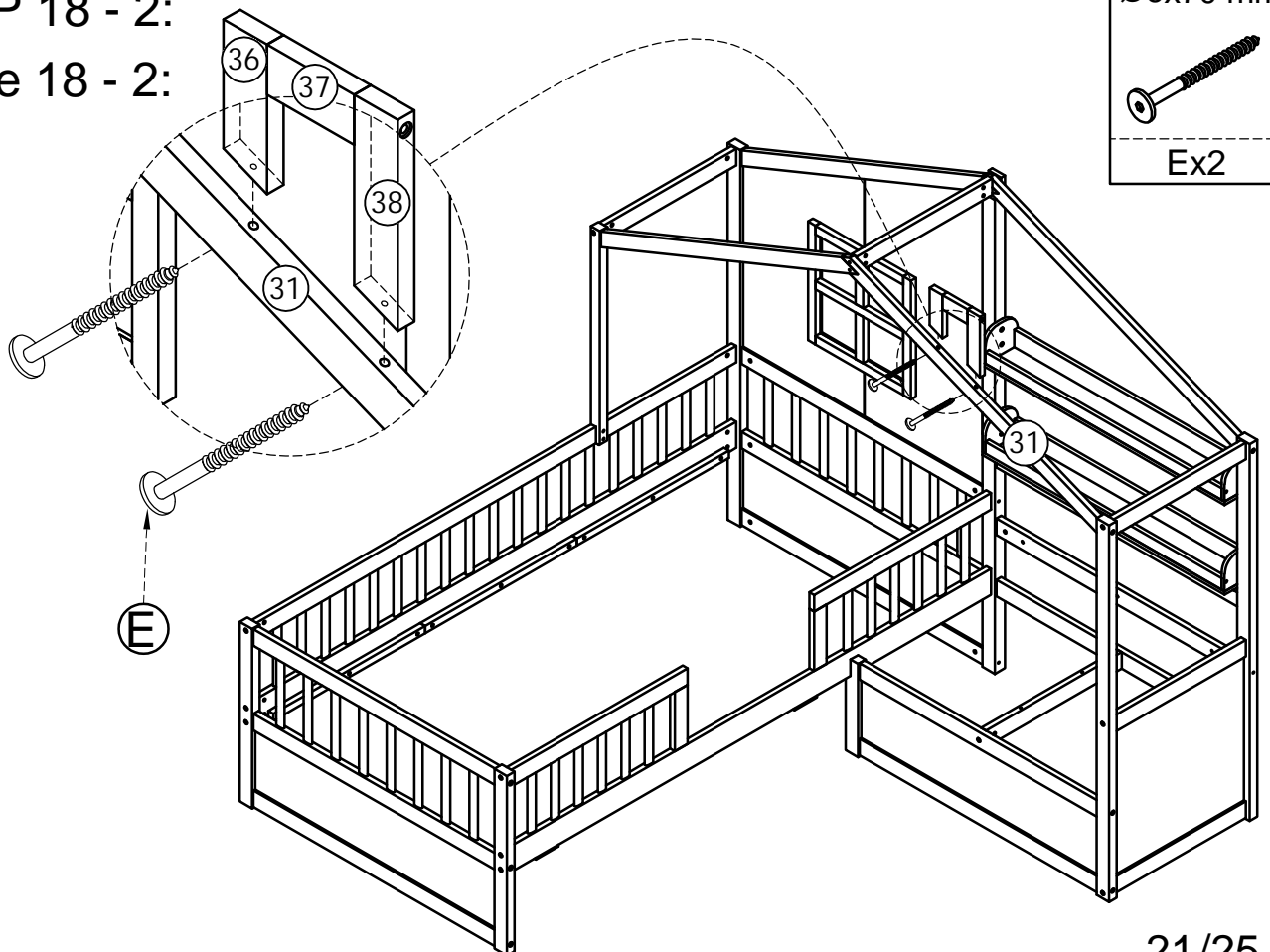
Ex2

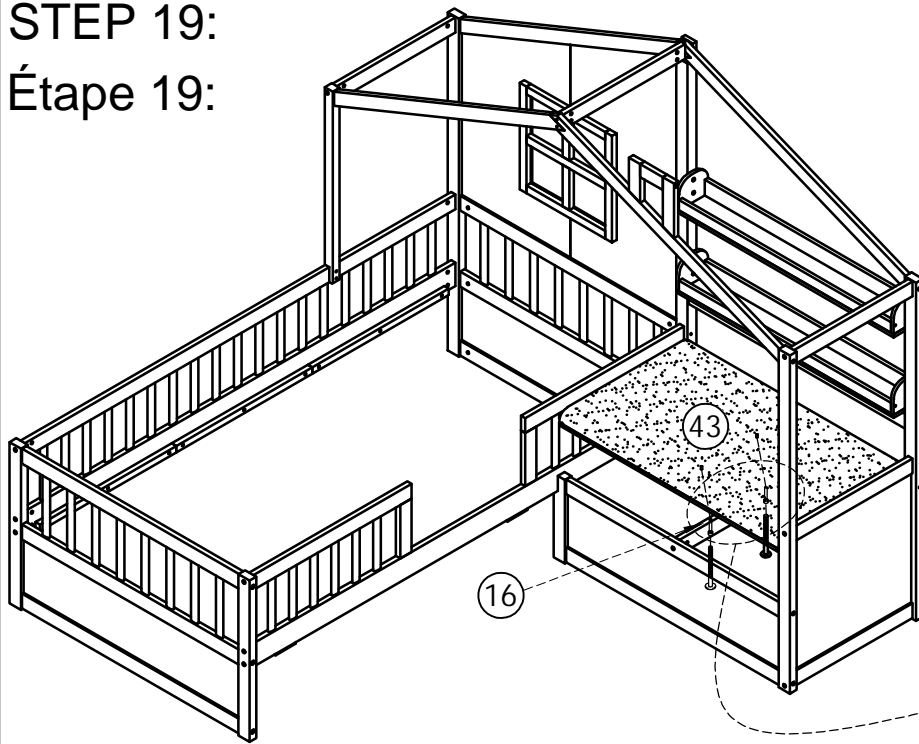

STEP 19:

Étape 19:



Ø6x70mm

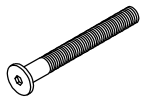

Bx2

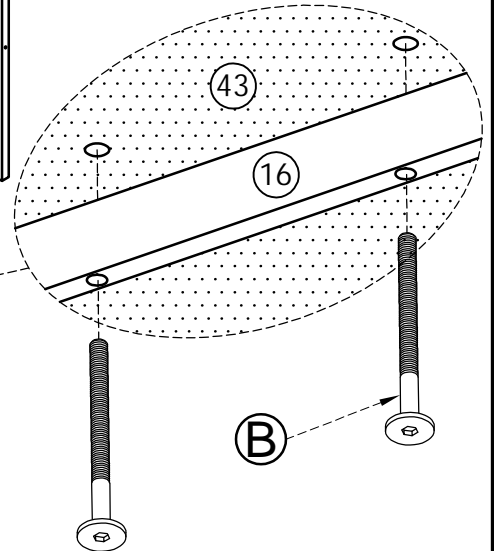

STEP 20:

Étape 20:

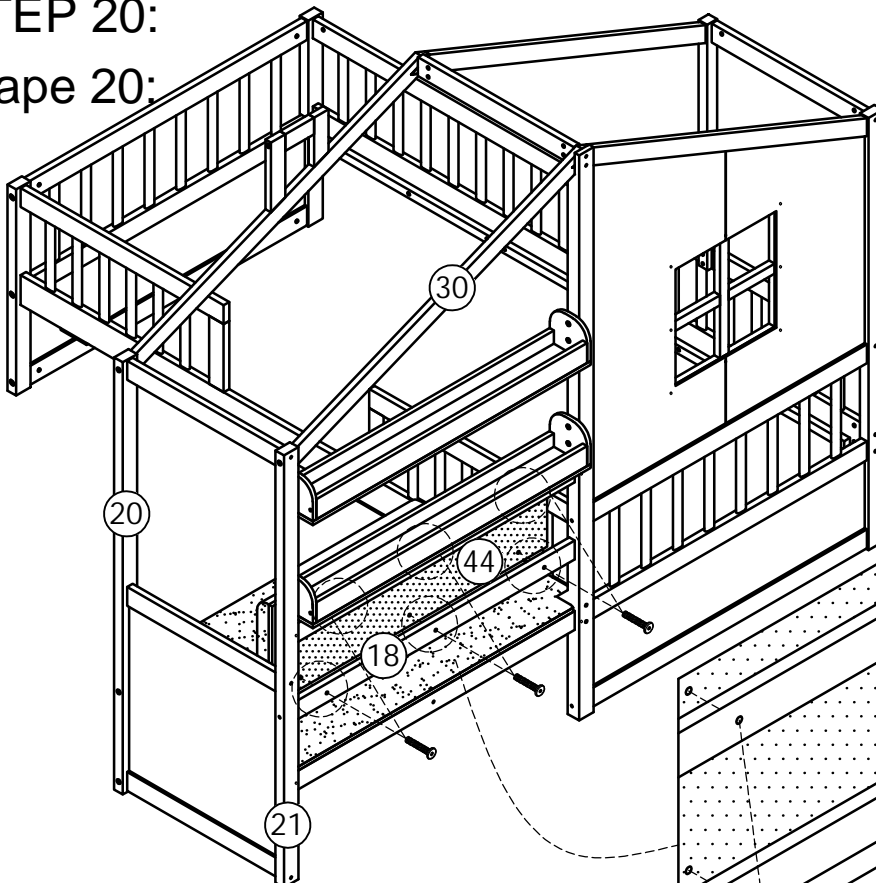

Ø6x30mm



Dx6

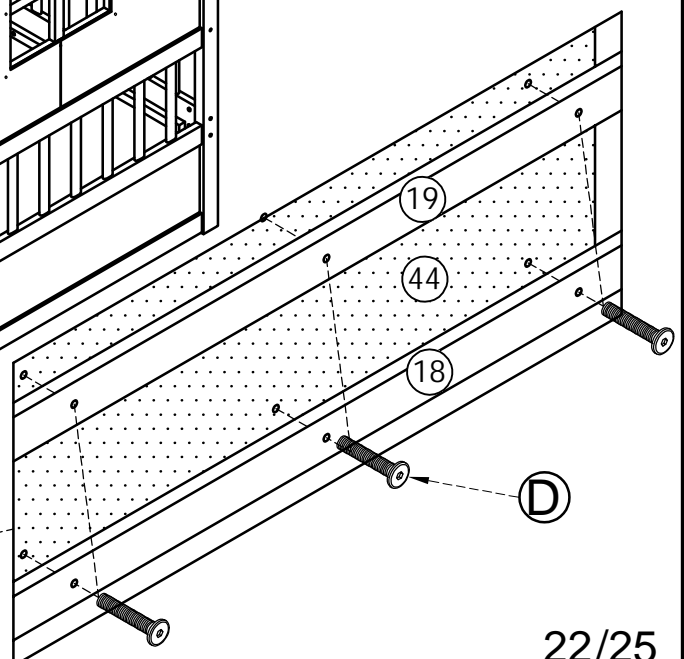

STEP 21:

Étape 21:

M4x30 mm



Hx20

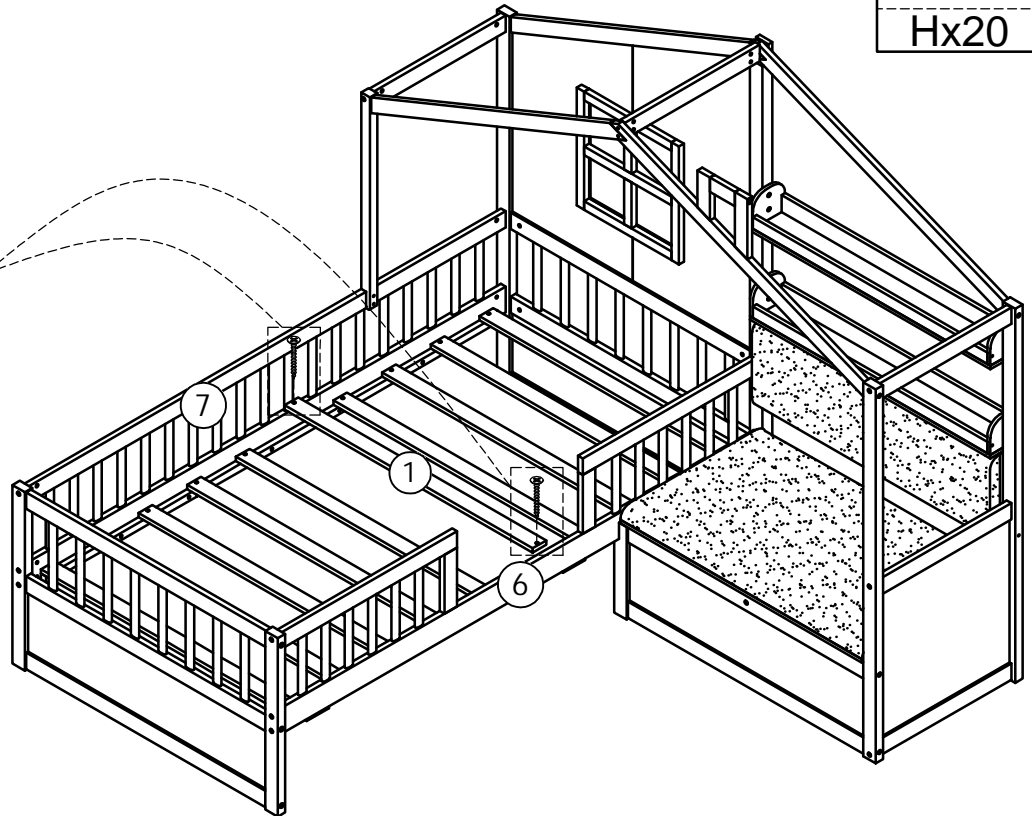
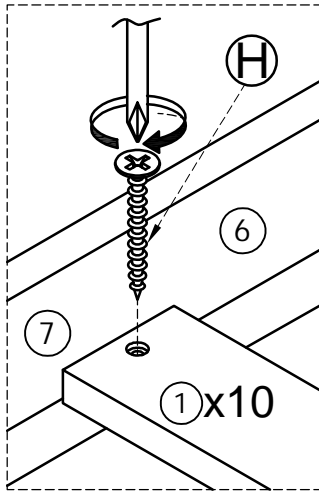

STEP 22 - 1:

Étape 22 - 1:

Ø6x25 mm



Nx4

Ø6x60mm

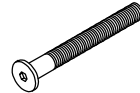

Cx2

Ø6x13mm



Px2

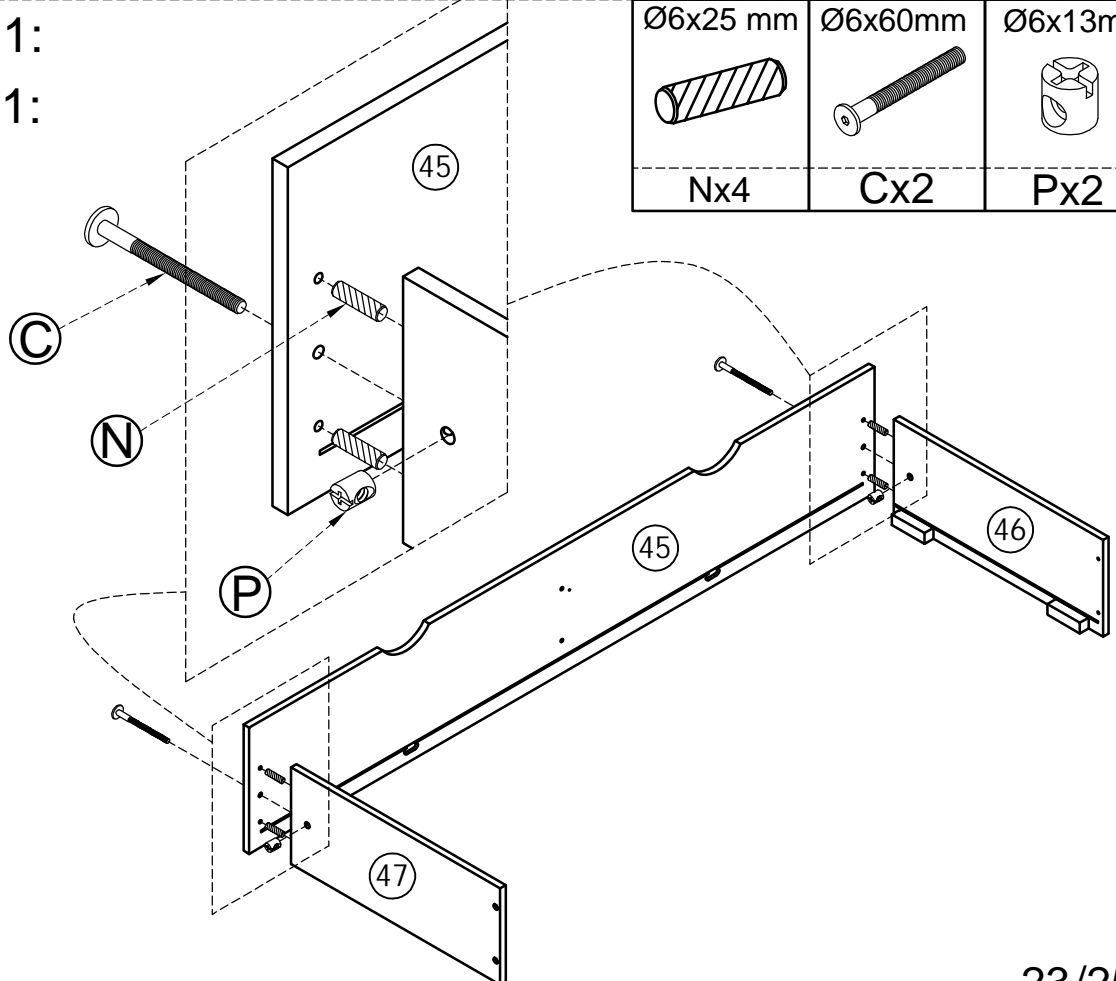

STEP 22 - 2:

Étape 22 - 2:

Ø6x25 mm

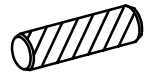

Nx2

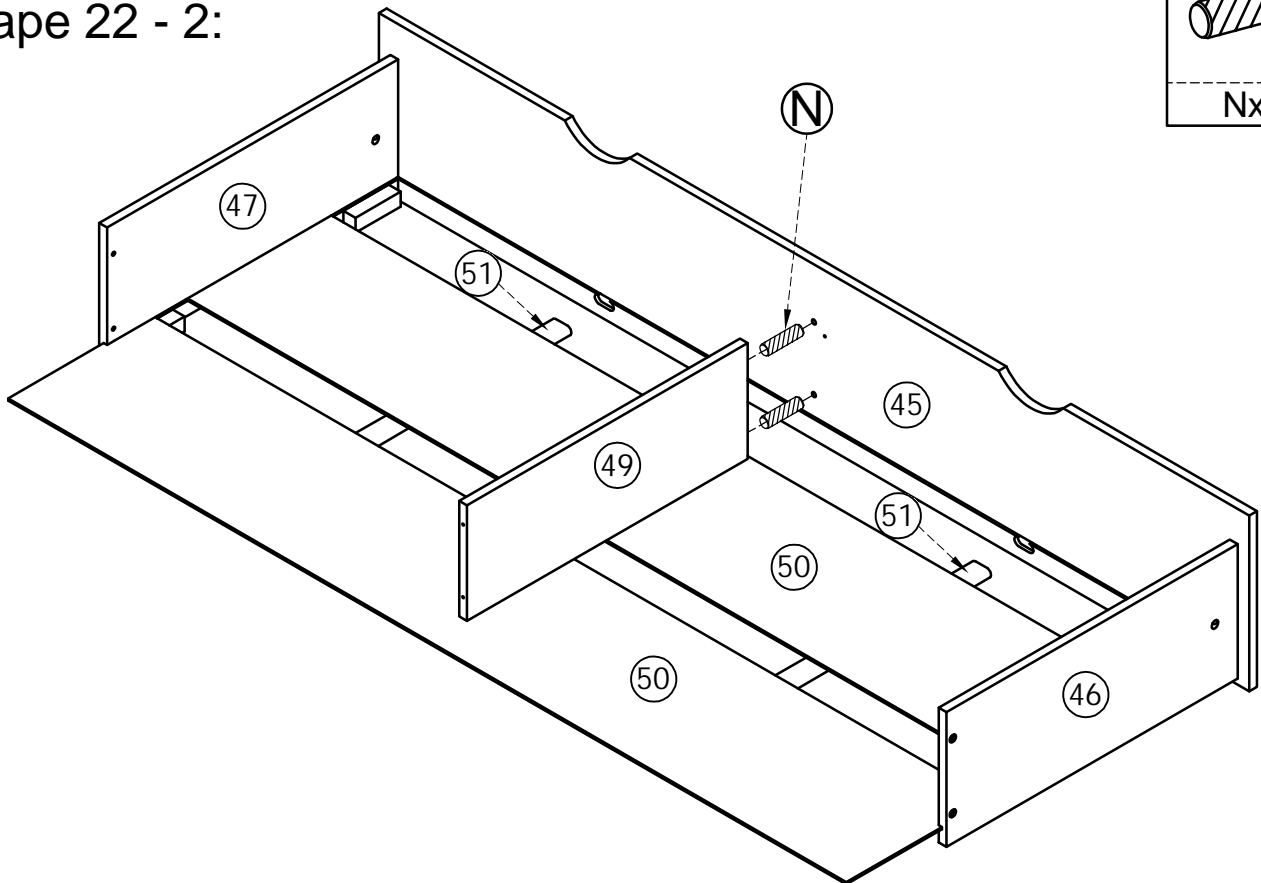

STEP 22 - 3:

Étape 22 - 3:

M4x30 mm



Hx8

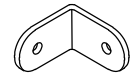

Qx1

M3.5x12mm



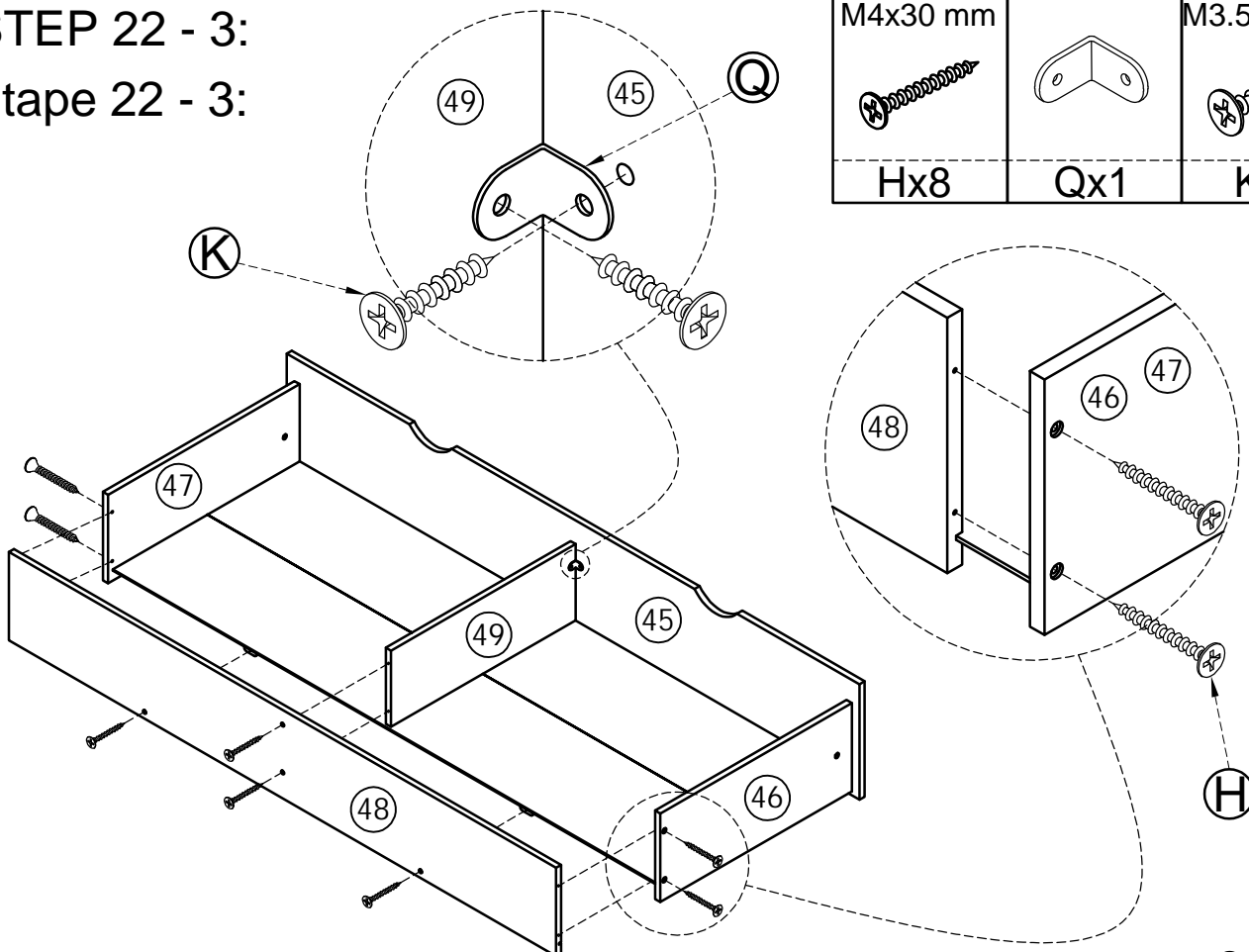

Kx2

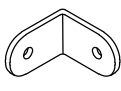

STEP 22 - 4:

Étape 22 - 4:

	M3.5x12mm	M4x15mm	
Qx2	Kx4	Lx10	Yx4

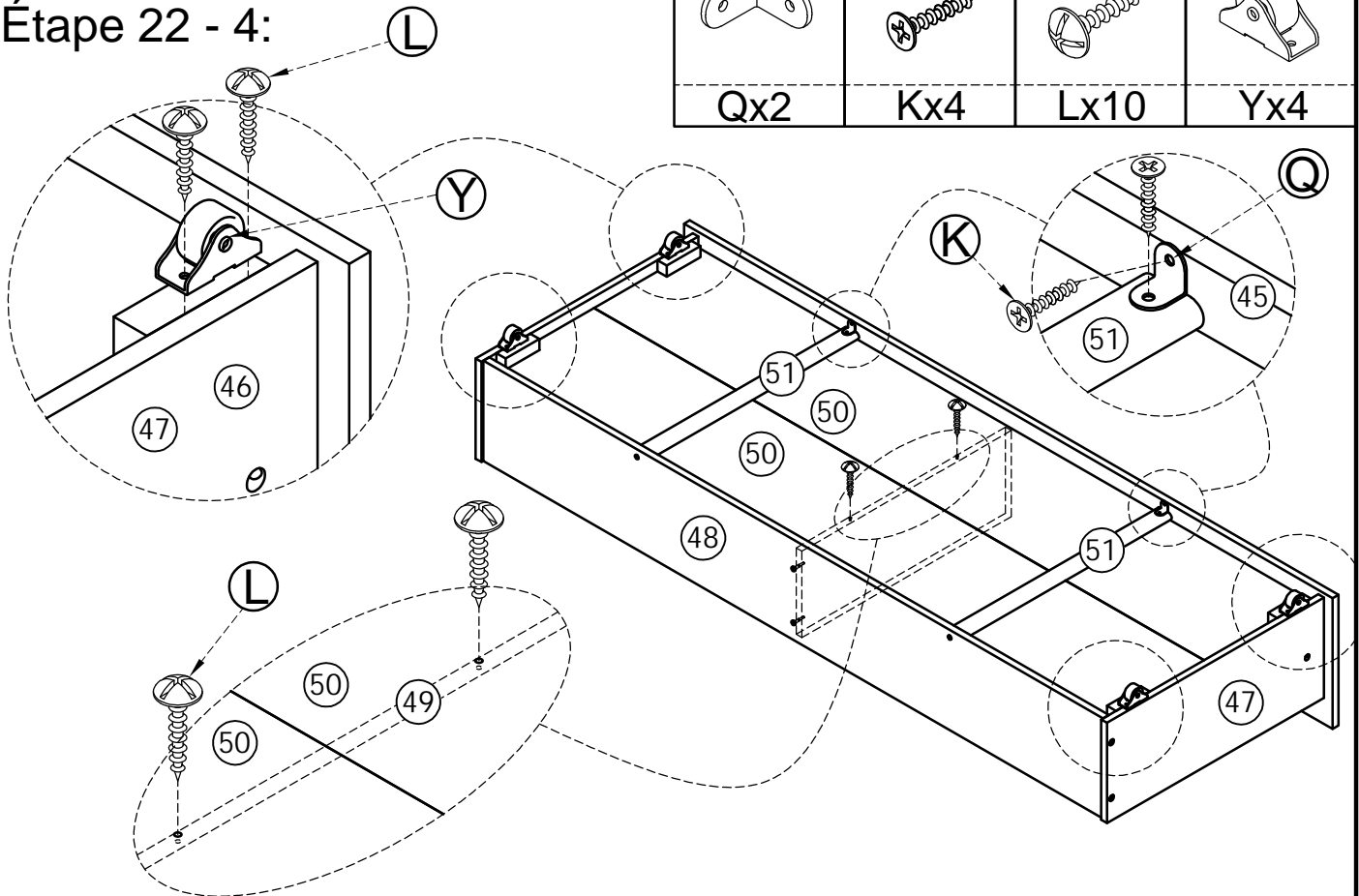

STEP 23:

Étape 23:

