

ASSEMBLY INSTRUCTION

DINING CHAIR

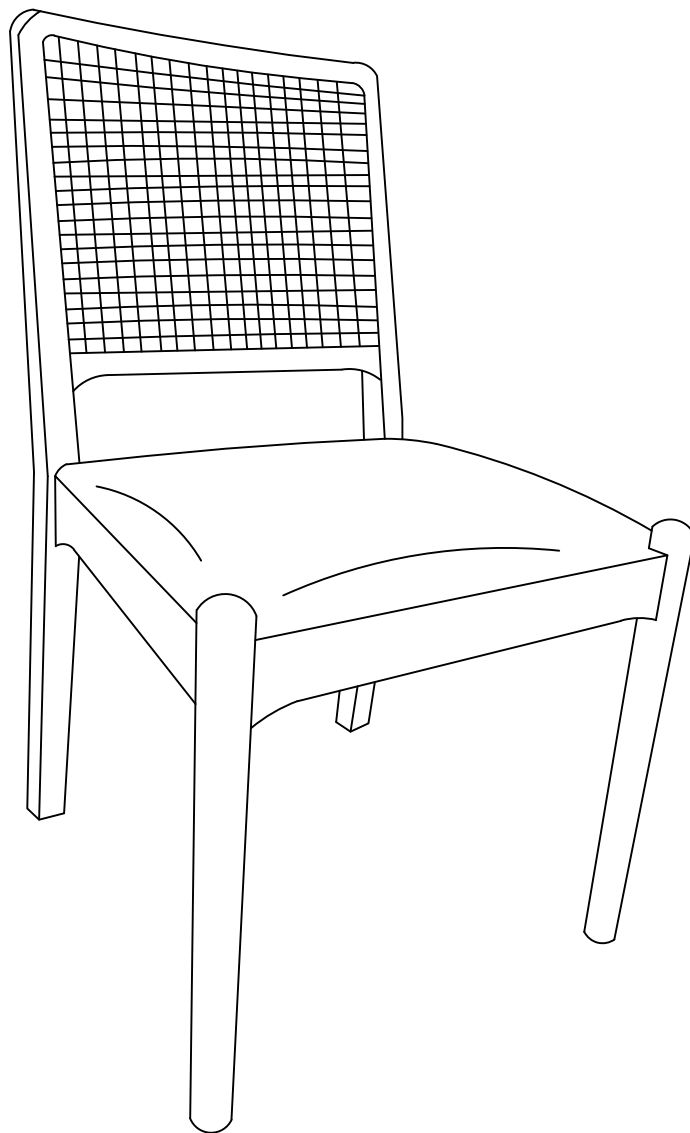

ASSEMBLY INSTRUCTION

Important Note !

Please read these instructions fully before starting assembly:

1. Place all wooden parts on a clean and smooth surface such as a rug or carpet to avoid scratching the parts
2. Kindly follow the assembly instructions step by step.
3. Do not tighten all screws and bolts until the table is fully assembled.
4. Unscrew the protective plastique supports from the metal insert of the chair legs before assembly.
5. Parts of the assembly will be easier with 2 people.





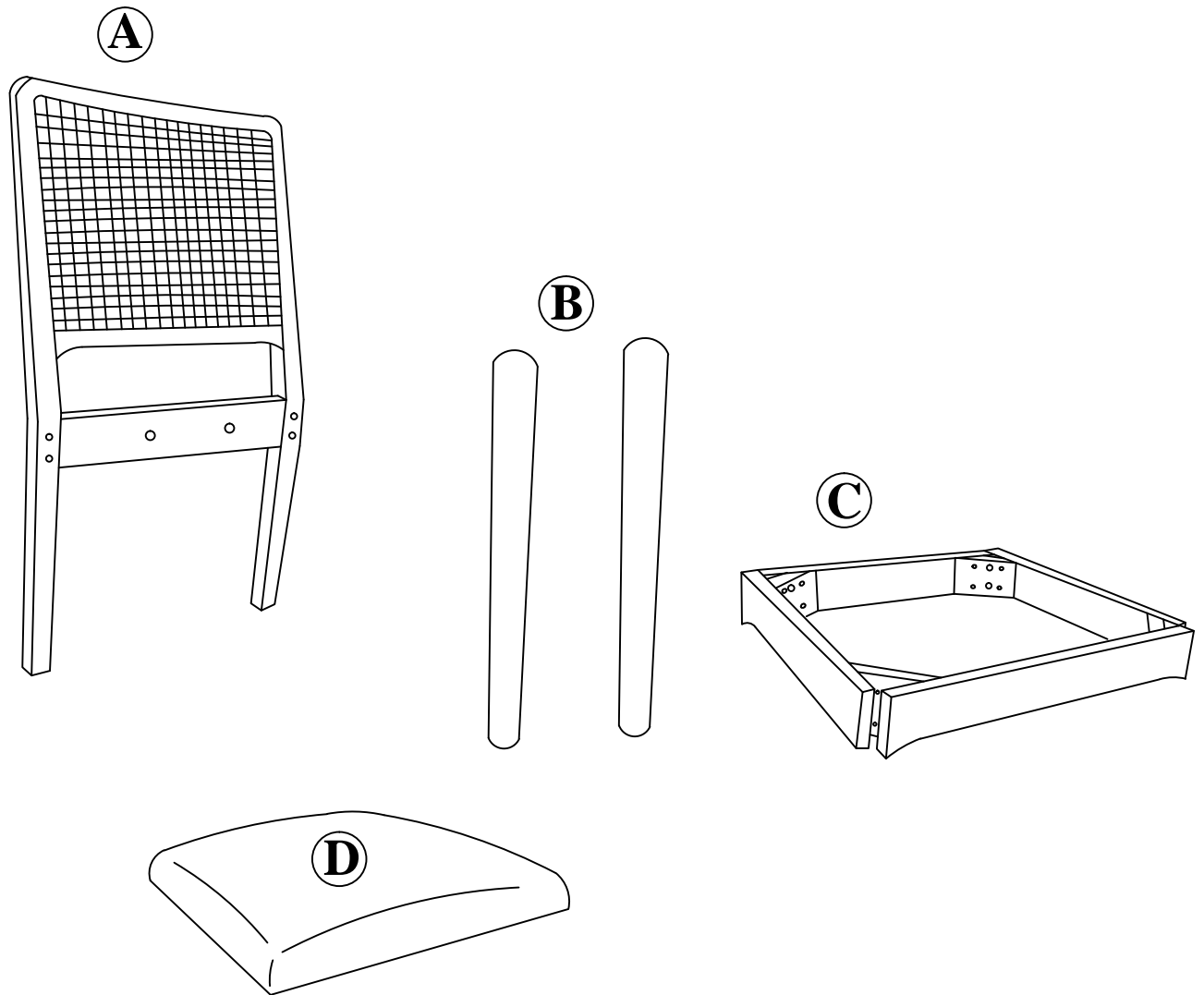

Care and maintenance:

Only clean using a damp cloth and mild detergent, do no use bleach or abrasive cleaners.

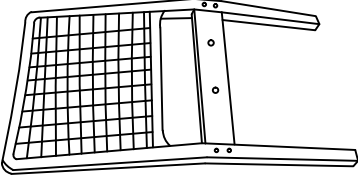
ASSEMBLY INSTRUCTION

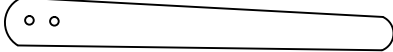

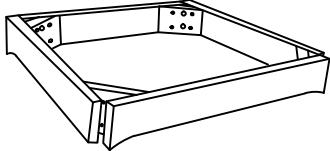
ASSEMBLY INSTRUCTION

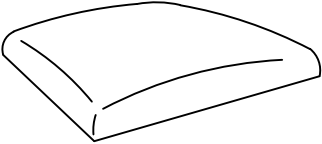
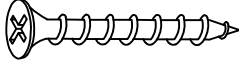
Part List For One	Hardware List For One
<p>A</p> 	<p>1</p>  <p>ALLEN KEY (1PC)</p>
<p>BACK REST (1PC)</p>	<p>2</p>  <p>M6*35mm BOLT (2PCS)</p>
<p>B</p> 	<p>3</p>  <p>M6*60mm BOLT (4PCS)</p>
<p>FRONT LEG (2PCS)</p>	<p>4</p>  <p>M6*80mm BOLT (4PCS)</p>
<p>C</p> 	<p>5</p>  <p>SPRING WASHER (10PCS)</p>
<p>BOX SEAT (1PC)</p>	<p>6</p>  <p>FLAT WASHER (10PCS)</p>
<p>D</p> 	<p>7</p>  <p>M4*32mm WOOD SCREW (5PCS)</p>
<p>CUSHION SEAT (1PC)</p>	

ASSEMBLY INSTRUCTION

STEP 1

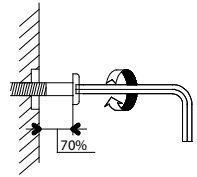
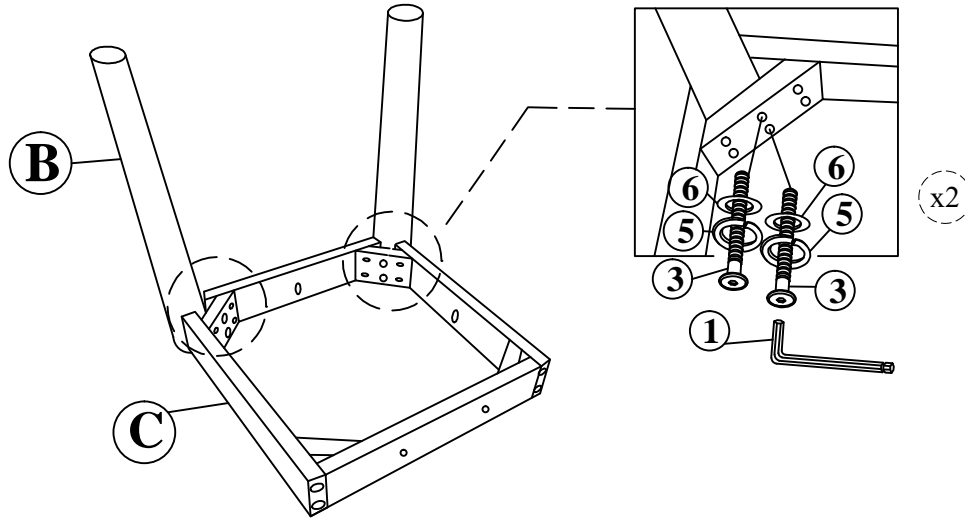

NOTE : Do not fully tighten the bolt

ALLEN KEY (1PC)	BOLT M6*60mm	SPRING WAHER	FLAT WASHER
① x 1	③ x 4	⑤ x 4	⑥ x 4

STEP 2

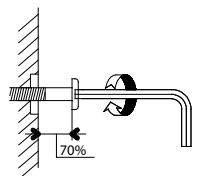
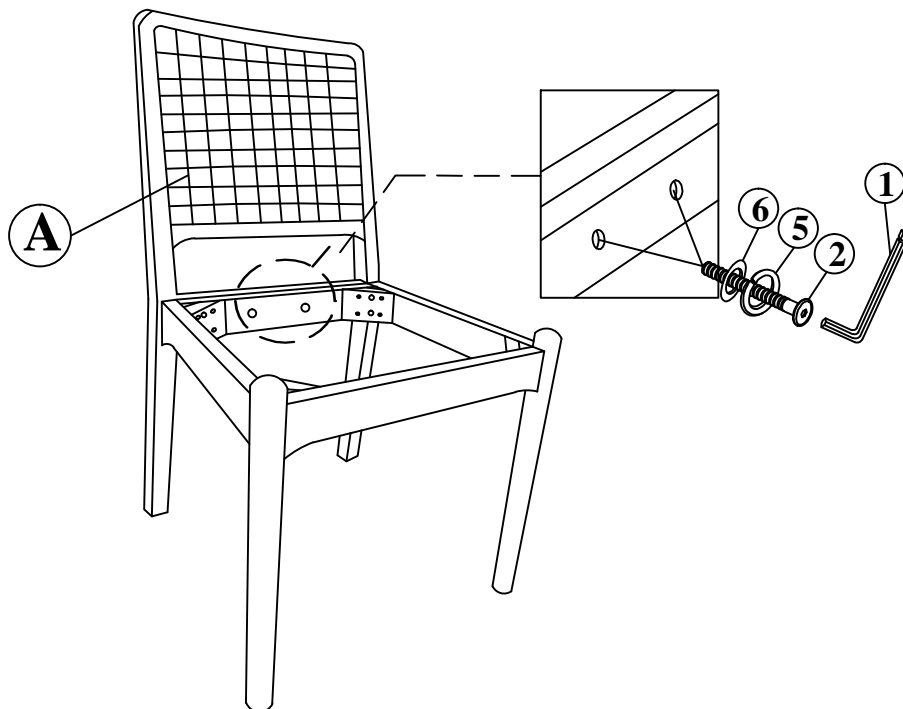

NOTE : Do not fully tighten the bolt



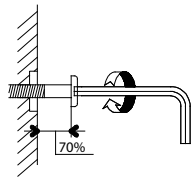
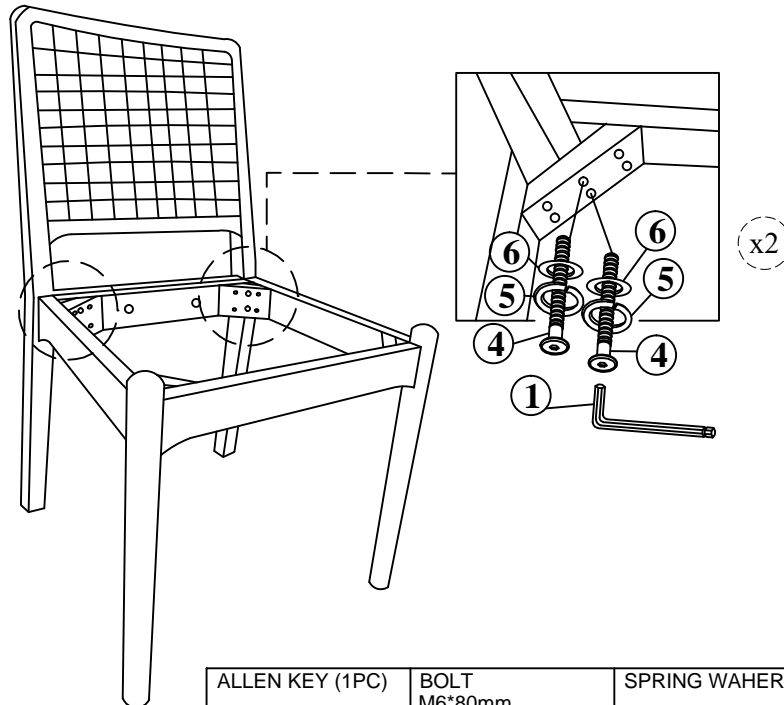

ALLEN KEY (1PC)	BOLT M6*35mm	SPRING WAHER	FLAT WASHER
① x 1	② x 2	⑤ x 2	⑥ x 2

ASSEMBLY INSTRUCTION

STEP 3



NOTE : Do not fully tighten the bolt

ALLEN KEY (1PC)	BOLT M6*80mm	SPRING WAHER	FLAT WASHER
			
① x 1	④ x 4	⑤ x 4	⑥ x 4

STEP 4

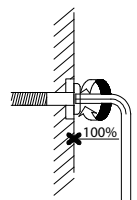
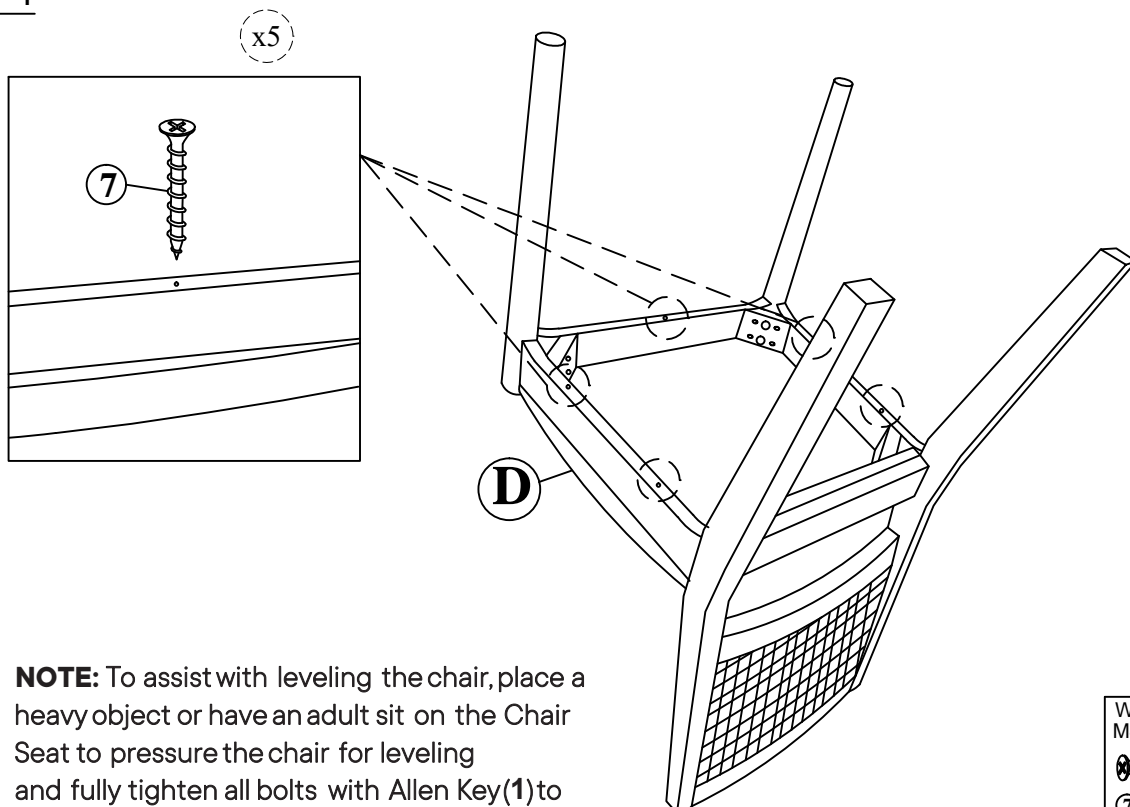

NOTE: To assist with leveling the chair, place a heavy object or have an adult sit on the Chair Seat to pressure the chair for leveling and fully tighten all bolts with Allen Key(1) to secure all legs.

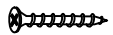
WOOD SCREW M4*32mm

⑦ x 5

ASSEMBLY INSTRUCTION

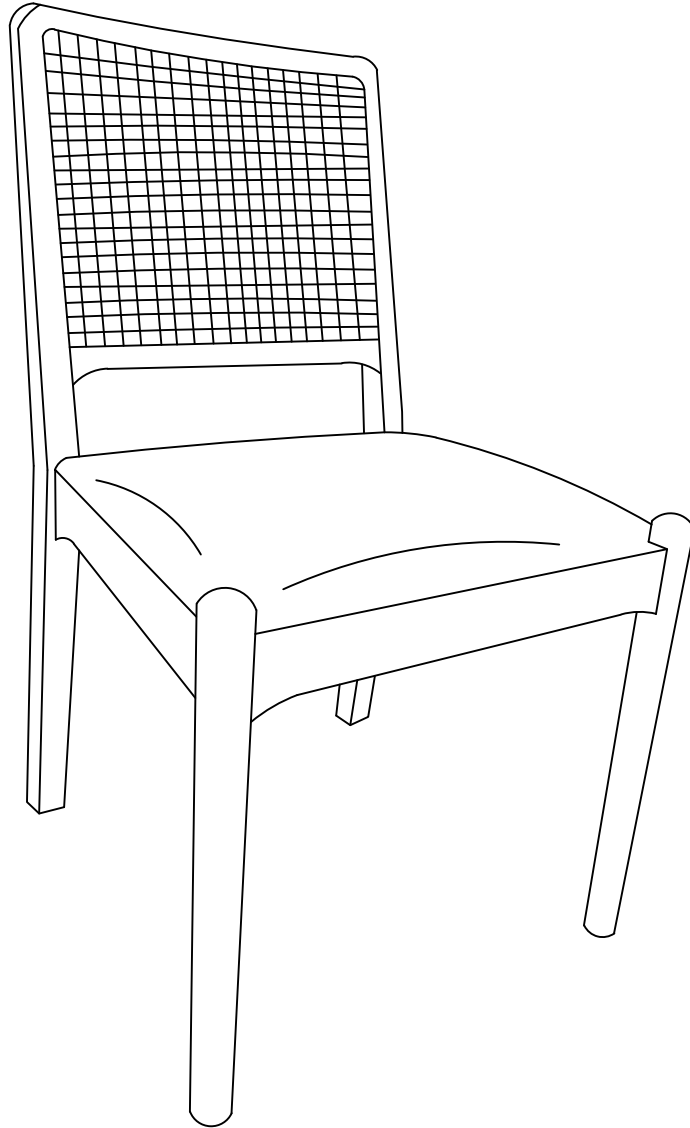
COMPLETE



ASSEMBLY INSTRUCTION

DINING TABLE

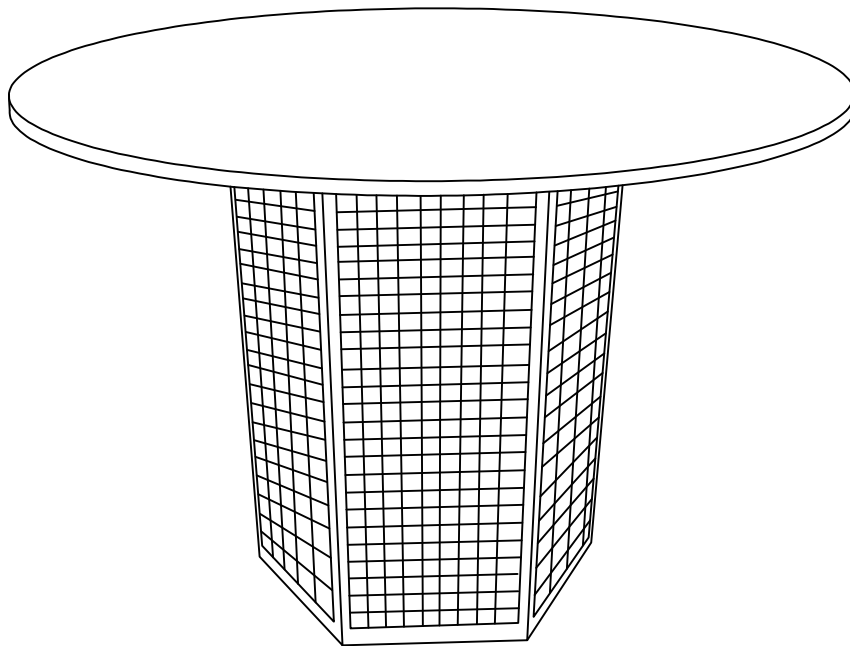

ASSEMBLY INSTRUCTION

Important Note !

Please read these instructions fully before starting assembly:

1. Place all wooden parts on a clean and smooth surface such as a rug or carpet to avoid scratching the parts
2. Kindly follow the assembly instructions step by step.
3. Do not tighten all screws and bolts until the table is fully assembled.
4. Unscrew the protective plastique supports from the metal insert of the table legs before assembly.
5. Parts of the assembly will be easier with 2 people.





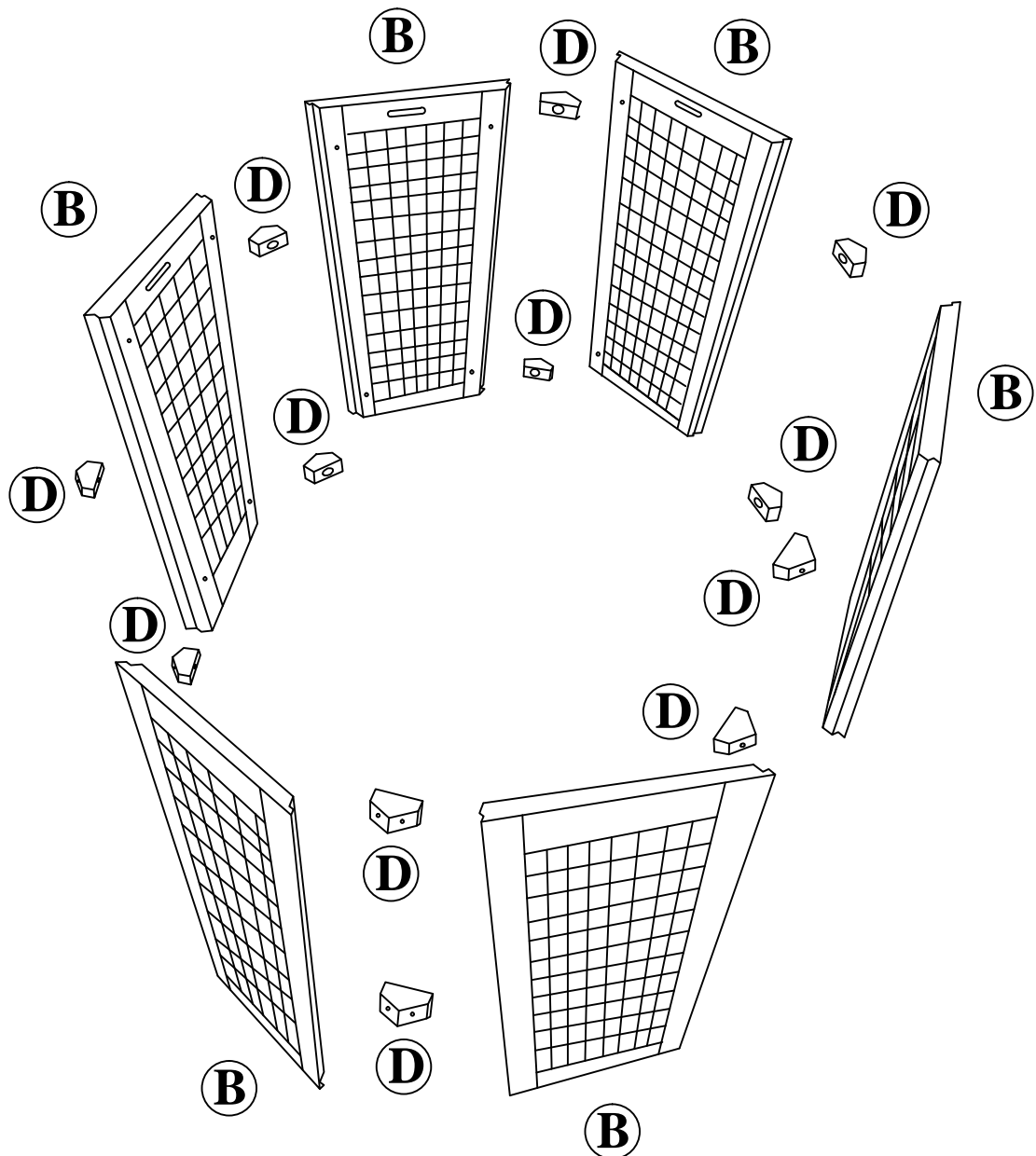
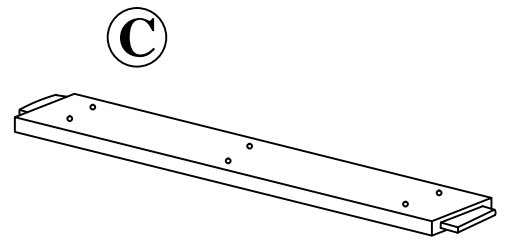
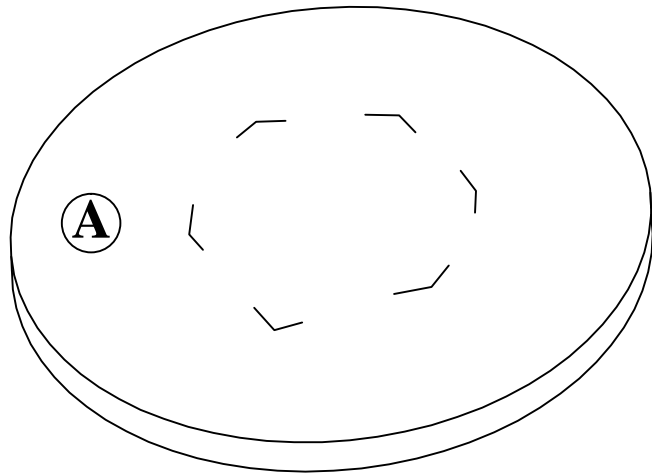

Care and maintenance:

Only clean using a damp cloth and mild detergent, do no use bleach or abrasive cleaners.

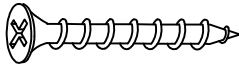
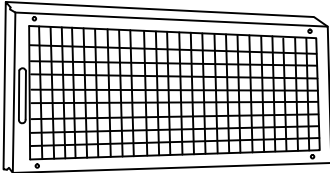
ASSEMBLY INSTRUCTION

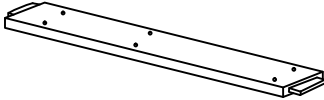

ASSEMBLY INSTRUCTION

Part List For One	Hardware List For One
<p>A</p> 	<p>1</p>  <p>M4*32mm</p>
<p>TABLE TOP (1PC)</p>	<p>WOOD SCREW (6PCS)</p>
<p>B</p> 	<p>2</p>  <p>M6*30mm</p>
<p>LEG (6PCS)</p>	<p>BOLT (24PCS)</p>
<p>C</p> 	<p>3</p> 
<p>SUPPORT (1PC)</p>	<p>SPRING WASHER (24PCS)</p>
<p>D</p> 	<p>4</p> 
<p>SMALL WOOD (12PCS)</p>	<p>ALLEN KEY (1PC)</p>

ASSEMBLY INSTRUCTION

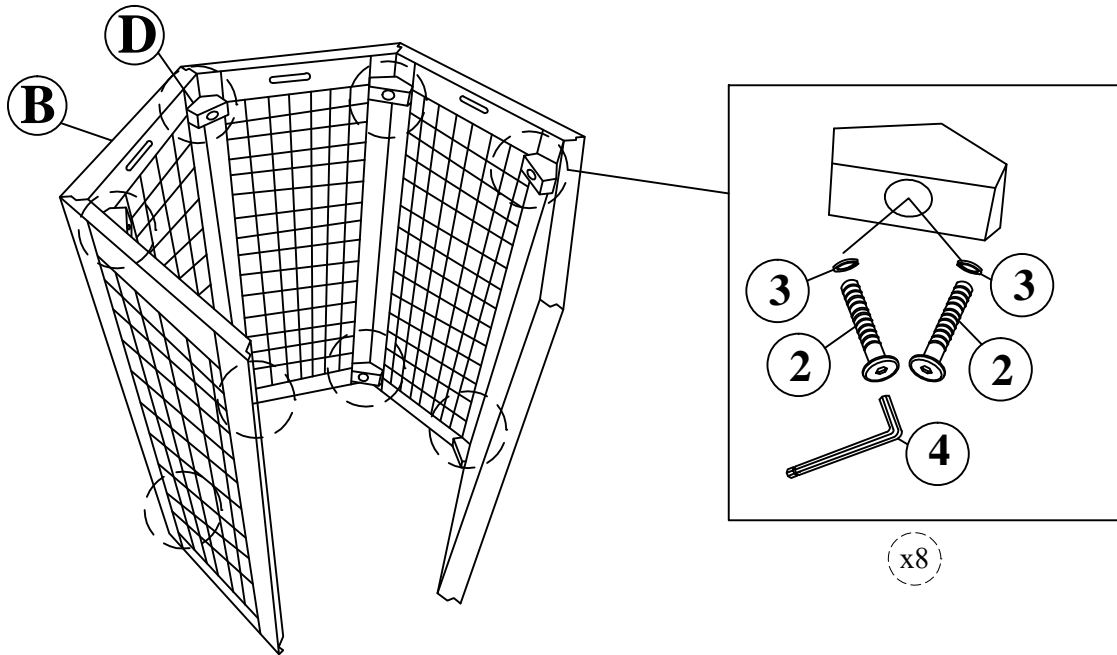

STEP 1

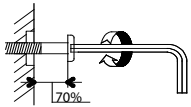

WARNING: Please install the parts with care and on a clean surface.





NOTE: Do not fully tighten the bolt

BOLT M6*60mm  ② x 16	SPRING WASHER  ③ x 16	ALLEN KEY (1PC)  ④ x 1
--	---	--

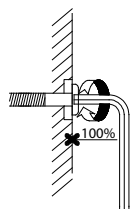
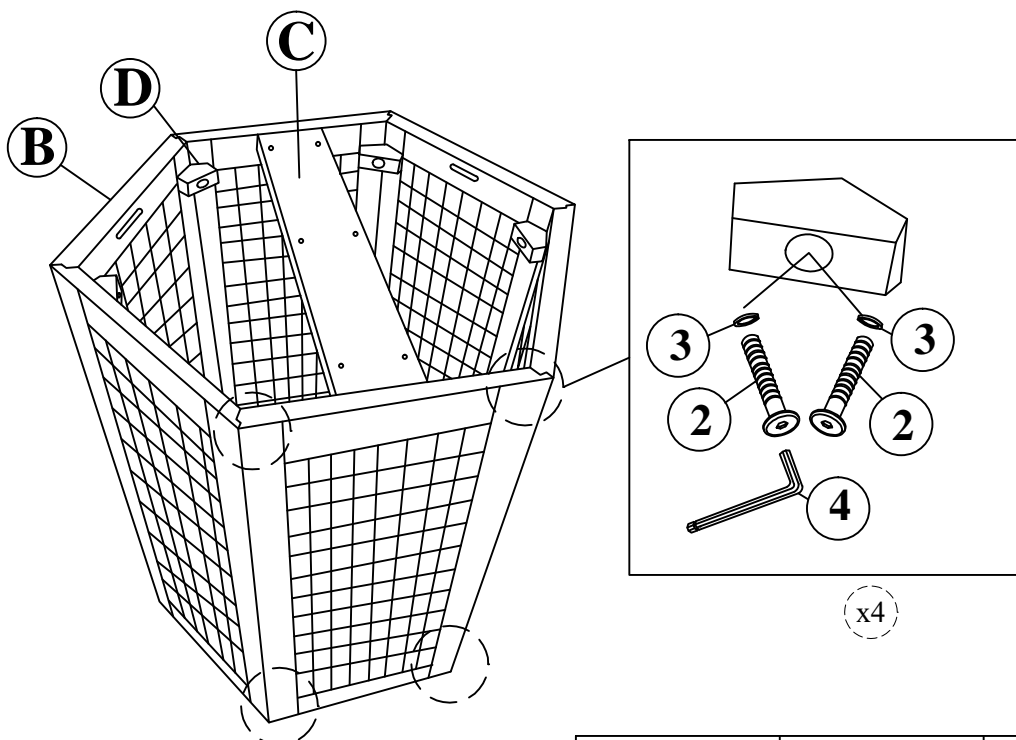
STEP 2



NOTE: Fully tighten all bolts with Allen Key (4) to secure all legs.

BOLT M6*60mm  ② x 8	SPRING WASHER  ③ x 8	ALLEN KEY (1PC)  ④ x 1
---	--	--

ASSEMBLY INSTRUCTION

STEP 3

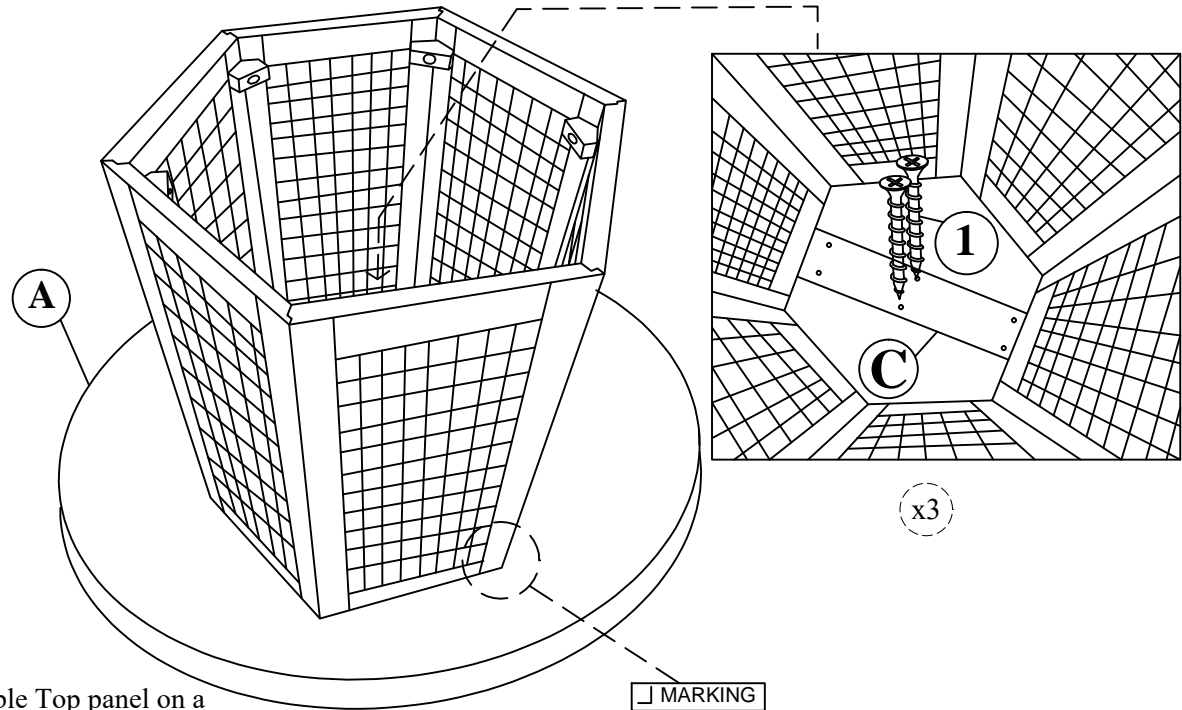

WARNING: Place the Table Top panel on a clean and smooth surface to avoid scratches!

- * There are no pre-drilled holes on the table , please align the legs with the marking line provided and screw directly with screwdriver or electric drill.

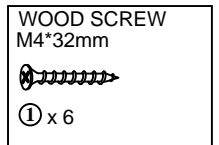

COMPLETE

