

# ***Changing Table***

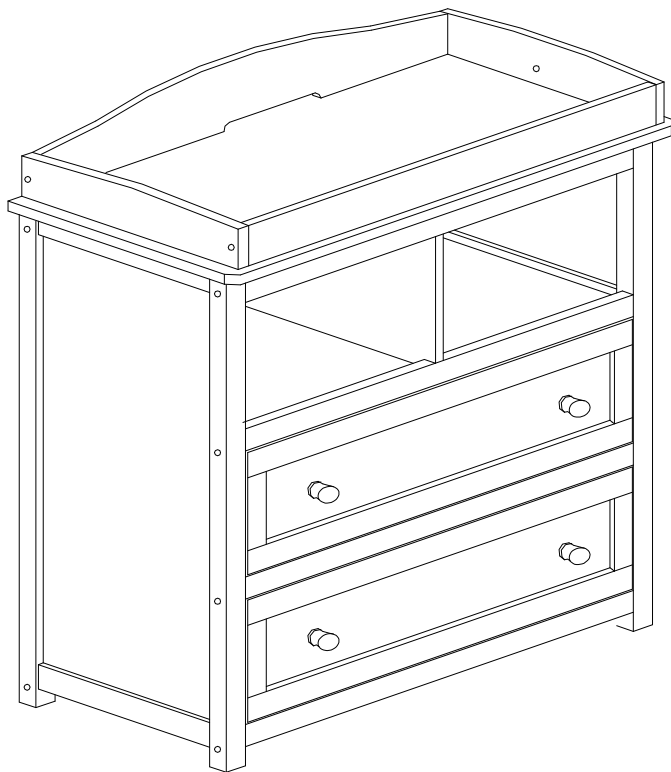

**THIS PRODUCT IS NOT INTENDED FOR INSTITUTIONAL OR COMMERCIAL USE.**

If you have any questions or missing parts, please contact us. DO NOT return product parts to the store where it was purchased before contacting our Customer Service.

# **WARNING:**

**READ ALL WARNING & SAFETY INSTRUCTIONS BEFORE ASSEMBLING PRODUCT. KEEP INSTRUCTIONS FOR FUTURE USE.**

**Storage:** The product must be kept in a dry and clean area.

**Care and Cleaning:** Do not scratch or chip the finish. Do not use abrasive chemicals for cleaning. Clean with mild soap on a soft rag. Rinse and dry thoroughly. If you choose to refinish this furniture, be sure to use only a non-toxic finish specified for children's products.

# **WARNING**

**FALL HAZARD – TO PREVENT DEATH OR SERIOUS INJURY ALWAYS KEEP CHILD WITHIN ARM'S REACH.**

- NEVER LEAVE THE CHILD UNATTENDED.
- SECURE THE CHILD IN THE RESTRAINT WHEN USING CHANGER.
- KEEP THE CHILD IN VIEW WHILE CHILD IS IN THE CHANGER.
- STOP USING THE CHANGER WHEN THE CHILD IS ABLE TO SIT UP OR ROLL OVER.
- PERIODICALLY CHECK FOR LOOSE OR WORN PARTS, TIGHTEN, REPAIR, OR REPLACE AS NEEDED.
- THIS PRODUCT IS FOR RESIDENTIAL USE ONLY. ANY INSTITUTIONAL USE IS STRICTLY PROHIBITED.
- CAN ONLY RETAIN CHILD WITH MAXIMUM WEIGHT UP TO 30 LBS.
- ALWAYS SECURE CHANGING PAD TO THE CHANGER SURFACE BY FASTENING THE BELTS.
- DO NOT USE CHANGING TABLE, ADD-ON CHANGING UNIT, OR CONTOURED CHANGING PAD IF IT IS DAMAGED OR BROKEN.
- THIS PRODUCT IS NOT INTENDED TO BE USED AS A CHANGING TABLE WITHOUT FASTENING THE SAFETY BELT. USE OF THE PRODUCT WITHOUT THIS MAY RESULT IN DEATH OR SERIOUS INJURY TO YOUR CHILD FROM FALLING. FOLLOW ALL INSTRUCTIONS ON ATTACHING AND USING THE SAFETY BELT.
- RECOMMEND PAD SIZE 34" x 17" x 1".

PARENT SHOULD ENSURE A SAFE ENVIRONMENT FOR THEIR CHILD BY CHECKING THE FURNITURE CAREFULLY BEFORE PLACING CHILD IN THE PRODUCT. PLEASE MAKE SURE EVERY COMPONENT IS PROPERLY AND SECURELY IN PLACE.

# **WARNING**

## IMPORTANT SAFETY NOTICE

This or any changer unit can tip or fall over for when not used for its intended purpose. This could potentially result in serious injury or death.







Keep your children and others safe by following these simple rules:

- Do not allow climbing on any changer unit.
- Do not leave drawers open when not in use.
- Do not allow standing in drawers
- Do not allow hanging from drawers.
- Do not allow standing on top of changer unit.
- Do not place heavy objects in drawers.
- Do not place heavy objects on top of the changer unit which can be pulled down on top of your child.
- To avoid head injury, do not allow your child to play underneath open drawers.
- Child must be securely fastened to changer unit when the unit is in use.
- Always monitor your child's activity when in the nursery.

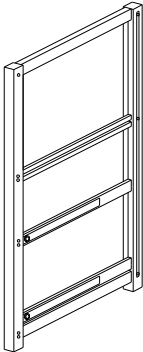
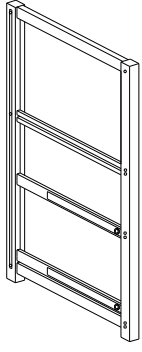
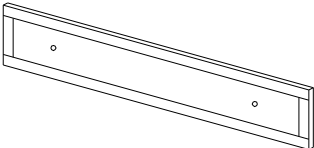
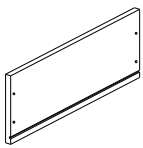
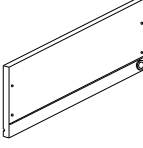
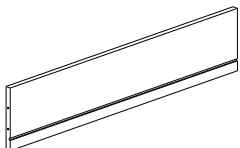

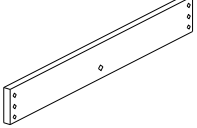
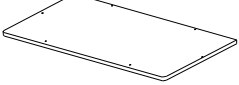
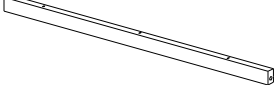
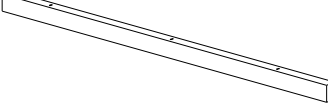
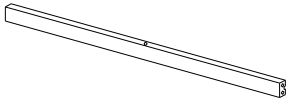
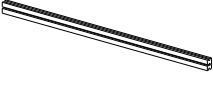
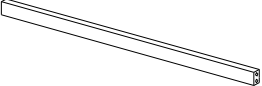
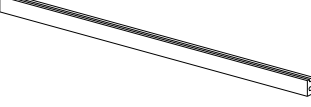
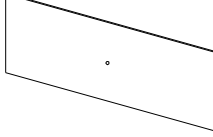

# Changer Parts Identification Sheet

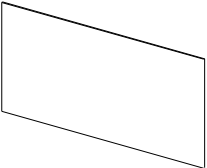
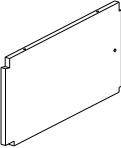
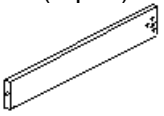
DO NOT assemble changer if parts and hardware are defective or missing.  
Contact us for exchange or keep the original box for return authorization.

## ~ Changer Assembly Parts

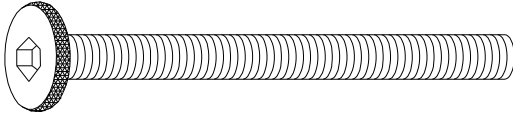
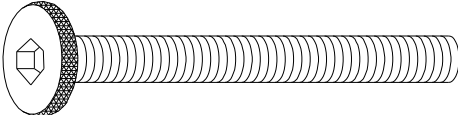
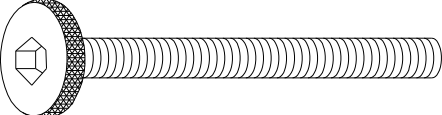
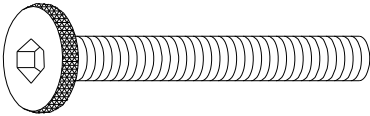
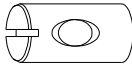
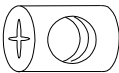
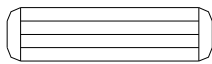
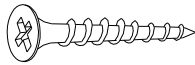
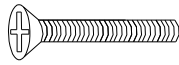
<p>A. Left Side Panel (1 pc)</p> 		<p>B. Right Side Panel (1 pc)</p> 	
<p>C. Drawer Front Panels (2 pcs)</p> 	<p>D. Drawer Left Panels (2 pcs)</p> 	<p>E. Drawer Right Panels (2 pcs)</p> 	<p>F. Drawer Back Panels (2 pcs)</p> 
<p>G. Drawer Bottom Panels (2 pcs)</p> 	<p>H. Top Front Panel (1 pc)</p> 	<p>I. Top Back Panel (1 pc)</p> 	<p>J. Top Side Panels (2 pcs)</p> 
<p>K. Top Panel (1 pc)</p> 	<p>L. Upper Front Rail (1 pc)</p> 	<p>M. Upper Back Rail (1 pc)</p> 	<p>N. Front Shelf Rail (1 pc)</p> 
<p>O. Back Shelf Rail (1 pc)</p> 	<p>P. Front Drawer Rails (2 pcs)</p> 	<p>Q. Back Drawer Rail (1 pc)</p> 	<p>R. Upper Back Panel (1 pc)</p> 
<p>S. Shelf (1 pc)</p> 	<p>T. Lower Back Panel (1 pc)</p> 	<p>U. Shelf Divider (1 pc)</p> 	<p>V. Drawer Support (2 pcs)</p> 

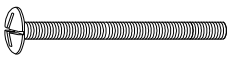
## ~ Changer Assembly Hardware

Item #	Fittings	Qty
1. Bolt 1/4" x 2-1/2"		(14 pcs)
2. Bolt 1/4" x 2-1/4"		(6 pcs)
3. Bolt 1/4" x 2-1/4"		(4 pcs)
4. Bolt 1/4" x 1-3/4"		(1 pc)
5. Barrel Nut 1/4" x 15 mm		(14 pcs)
6. Barrel Nut 1/4" x 13 mm		(11 pcs)
7. Dowel 8mm x 30 mm		(17 pcs)
8. Screw F4 x 25 mm		(20 pcs)
9. Machine Screw 3/16" x 1"		(6 pcs)
10. Knob		(4 pcs)
11. Bolt 5/32" x 3/4"		(4 pcs)
12. Wrench		(1 pc)

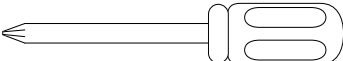
PHILLIPS SCREWDRIVER   (NOT INCLUDED)

# Changer Parts Diagram

Please follow this Parts Diagram to make sure that all parts are assembled in the correct position.

## ~ Changer Drawer

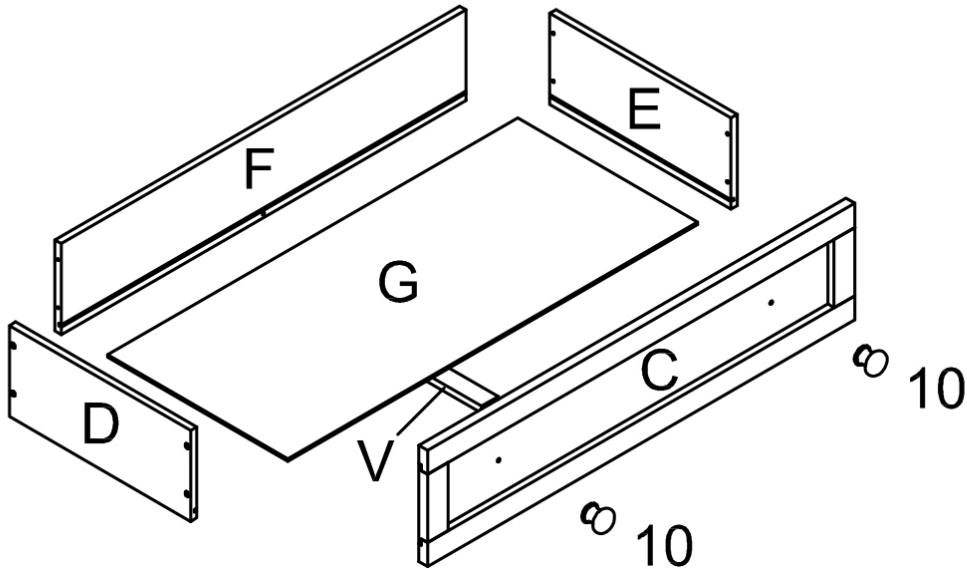

C.	Drawer Front Panel	(1 pc)	D.	Drawer Left Panel	(1 pc)
E.	Drawer Right Panel	(1 pc)	F.	Drawer Back Panel	(1 pc)
G.	Drawer Bottom Panel	(1 pc)	10.	Knobs	(2 pcs)
V.	Drawer Support	(1 pc)			

## ~ Changer Top

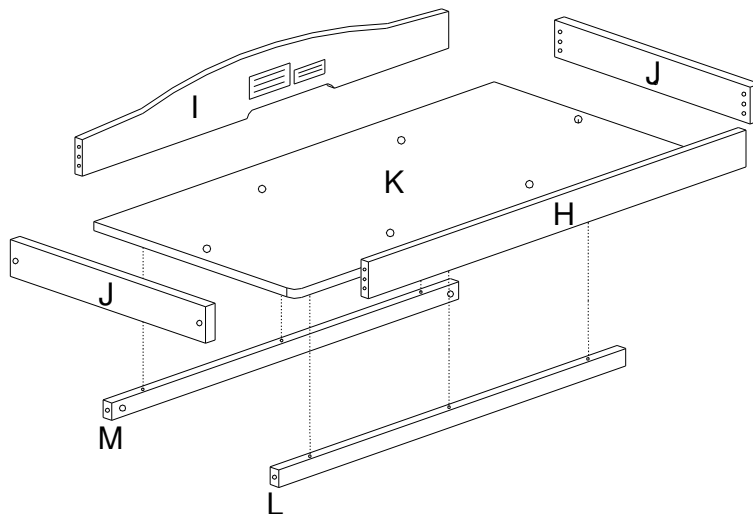

H.	Top Front Panel	(1 pc)	I.	Top Back Panel	(1 pc)
J.	Top Side Panels	(2 pcs)	K.	Top Panel	(1 pc)
L.	Upper Front Rail	(1 pc)	M.	Upper Back Rail	(1 pc)

# Changer Parts Diagram

Please follow this Parts Diagram to make sure that all parts are assembled in the correct position.

## ~ Changer Unit

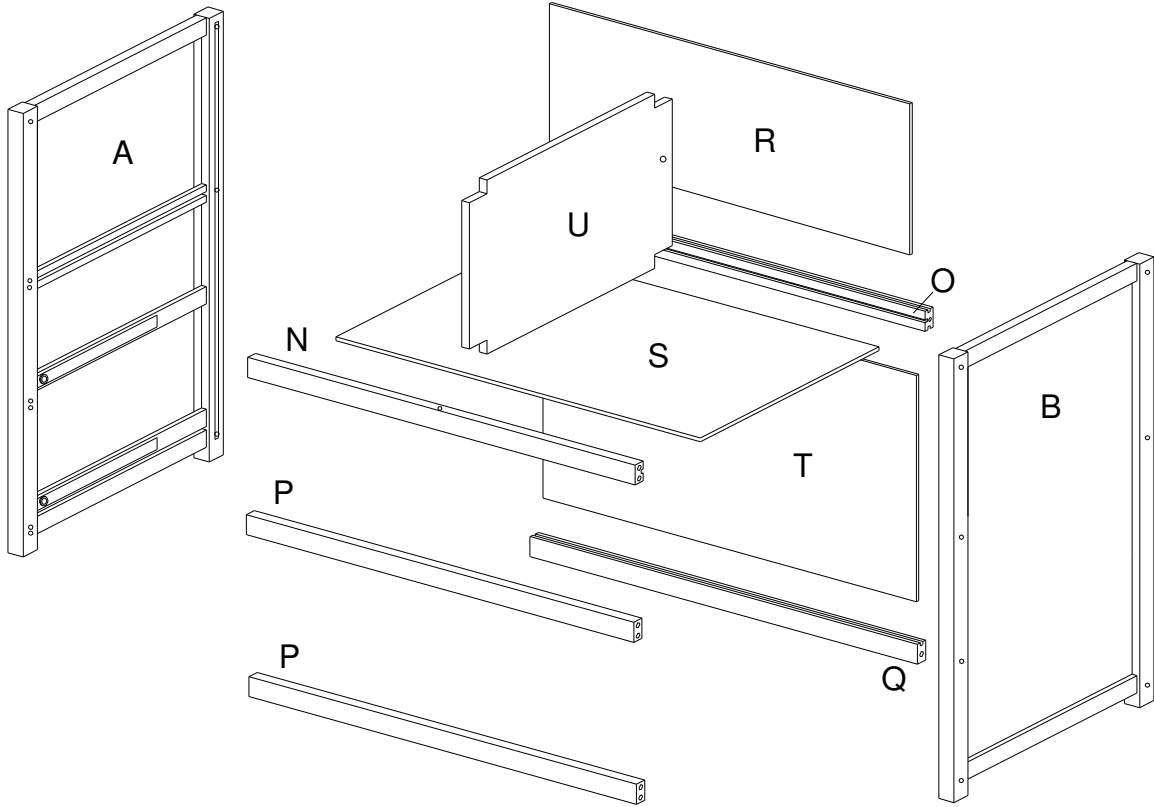

A.	Left Side Panel	(1 pc)
B.	Right Side Panel	(1 pc)
N.	Front Shelf Rail	(1 pc)
O.	Back Shelf Rail	(1 pc)
P.	Front Drawer Rails	(2 pcs)
Q.	Back Drawer Rail	(1 pc)
R.	Upper Back Panel	(1 pc)
S.	Shelf	(1 pc)
T.	Lower Back Panel	(1 pc)
U.	Shelf Divider	(1 pc)

# Changer Drawer Assembly Sheet

## STEP 1:

Attach Drawer Left Side Panel (D) and Drawer Right Side Panel (E) to Drawer Front Panel (C) with 4 screws (#8).

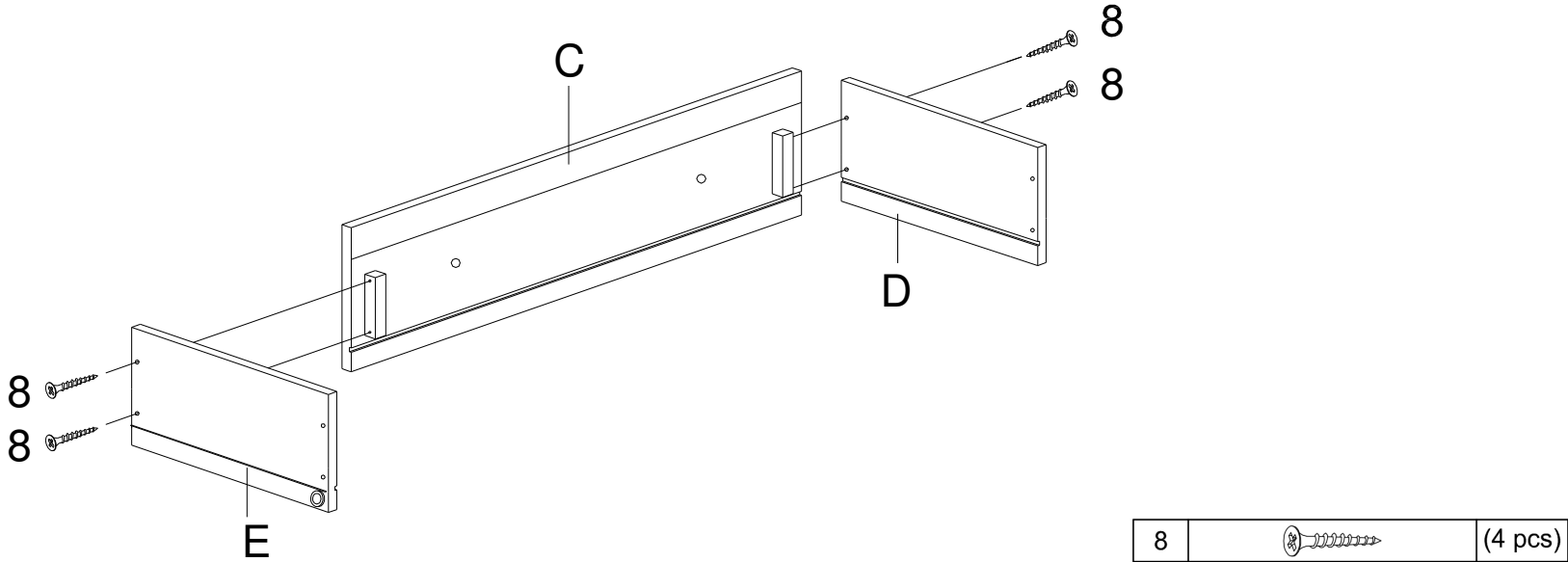

## STEP 2:

Slide Drawer Bottom Panel (G) into the grooves of the side panels.

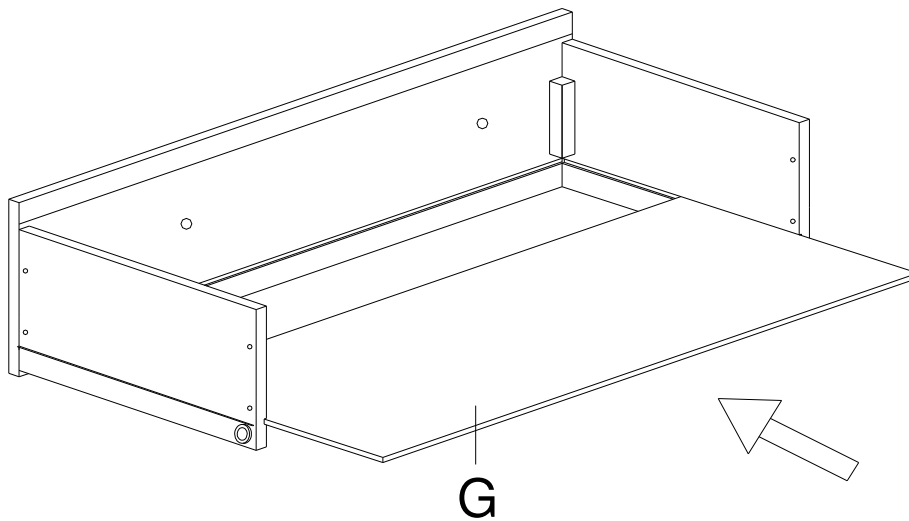

# Changer Drawer Assembly Sheet

---

**STEP 3:**

Attach Drawer Back Panel (F) to side panels with 4 screws (#8). Make sure all screws are tightly secured.

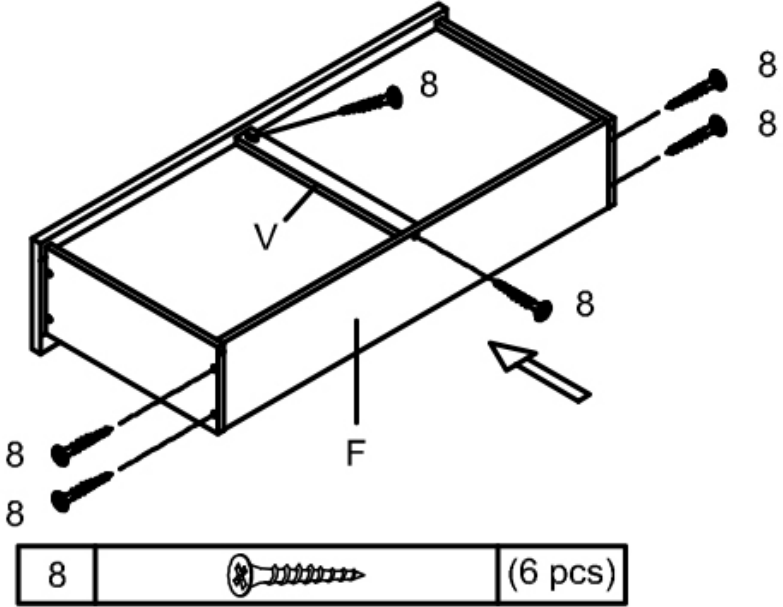

**STEP 4:**

Attach Knobs (#10) to Drawer Front Panel with 2 Bolts (#11).

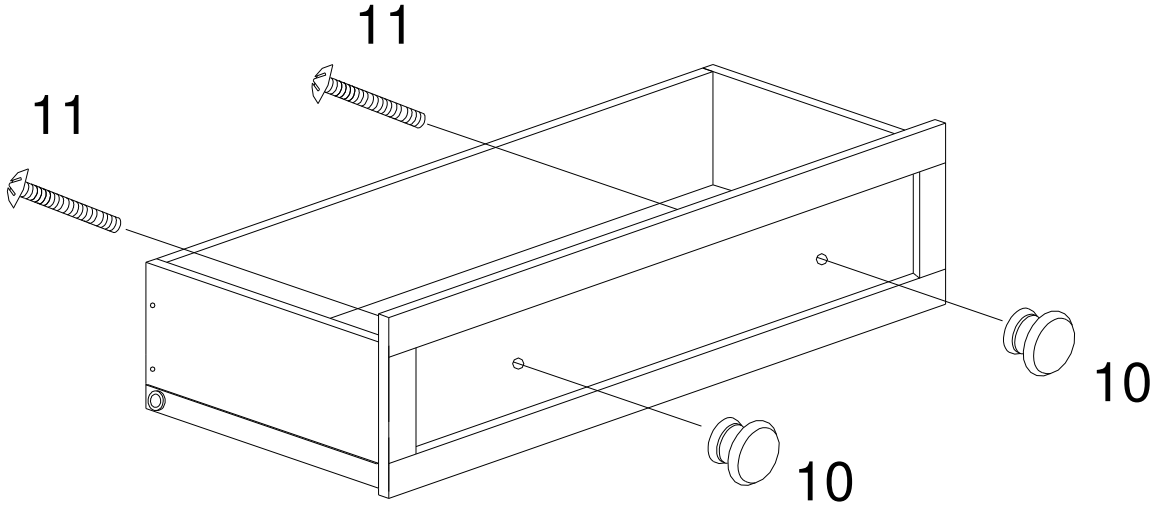

10.		(2 pcs)
11.		(2 pcs)

Repeat above steps to assemble the other drawer.



# Changer Top Assembly Sheet

## STEP 1:

- Insert 8 Dowels (#7) into top and bottom holes on each end of both Top Front Panel (H) and Top Back Panel (I).
- Attach 2 Top Side Panels (J) to Top Front Panel (H) and Top Back Panel (I) by using 4 Barrel Nuts (#6) of each corner of top panels before inserting 4 Bolts (#3). Warning labels must be **UPRIGHT** and facing **INWARD**. Tighten firmly with Wrench (#12).

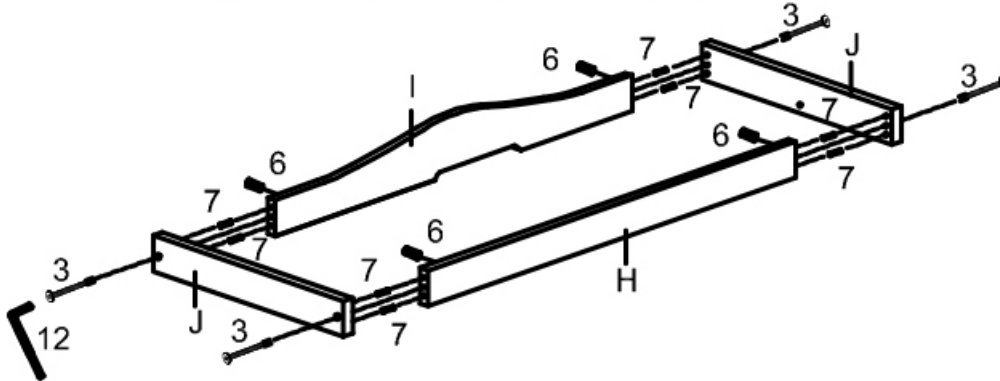

12.		(1 pc)	3.		(4 pcs)
6.		(4 pcs)	7.		(8 pcs)

## STEP 2:

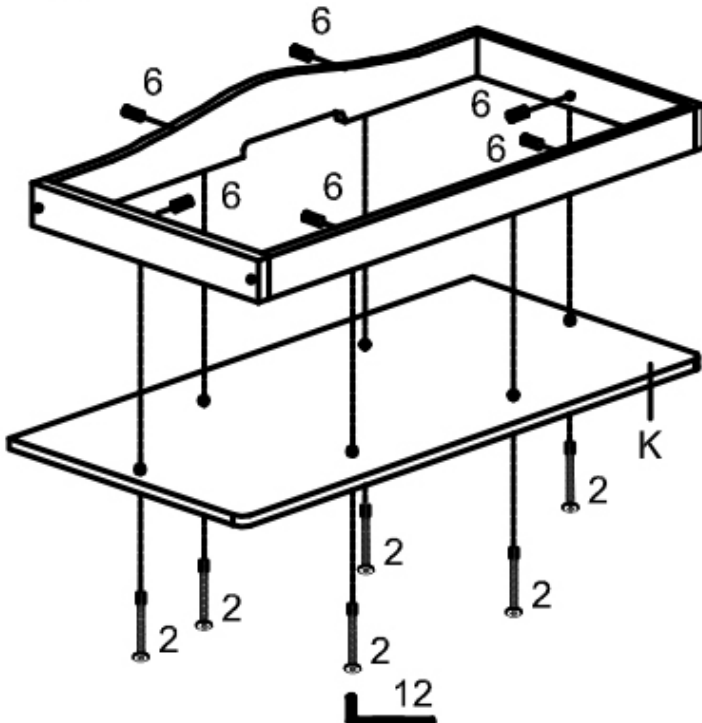

Insert Barrel Nuts (#6) into Top Front Panel, Top Back Panel and Top Side Panels before inserting Bolts (#2) from the underside of Top Panel (K). Tighten firmly with Wrench (#12).

12.		(1 pc)
2.		(6 pcs)
6.		(6 pcs)

# Changer Top Assembly Sheet

## STEP 3:

Turn the changer top bottom side up, and then attach Upper Front Rail (L) and Upper Back Rail (M) to Top Panel with 6 Bolts (#9). Tighten firmly with Phillips Head Screwdriver (Not included).

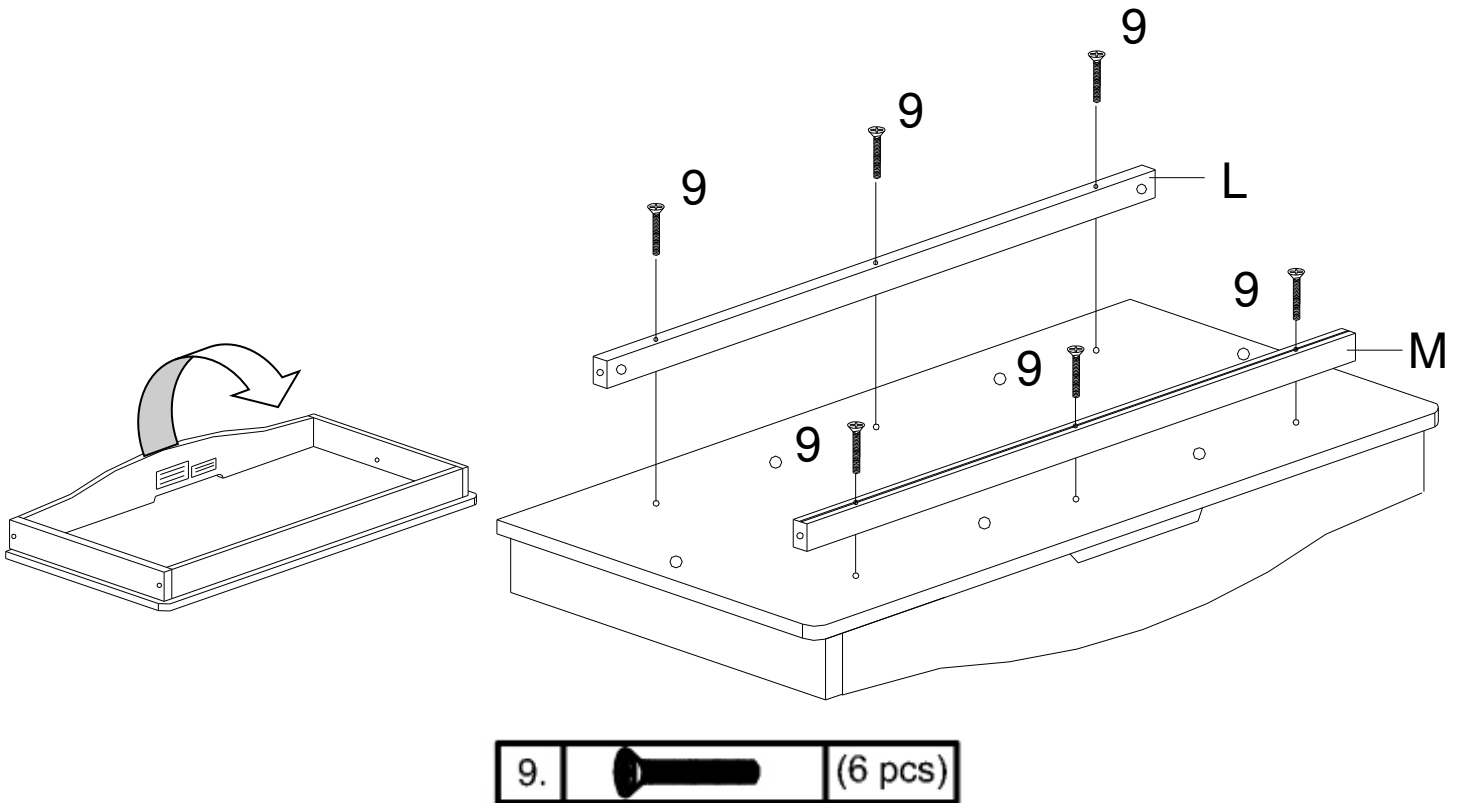

# Changer Assembly Sheet

**STEP 1: Note: For easier assembly, place Left Side Panel (A) flat on the ground.**

- Insert 3 Dowels (#7) into top holes on each end of Front Shelf Rail (N) and Front Drawer Rails (P).
- Attach Front Shelf Rail (N) (make sure middle hole is facing up), Back Shelf Rail (O) (make sure flat side is facing rear), Front Drawer Rails (P) and Back Drawer Rail (Q) (make sure the groove is facing up) to Left Side Panel (A) by using 5 Barrel Nuts (#5) on the underside of left side of all rails before inserting Bolts (#1). Tighten firmly with Wrench (#12).

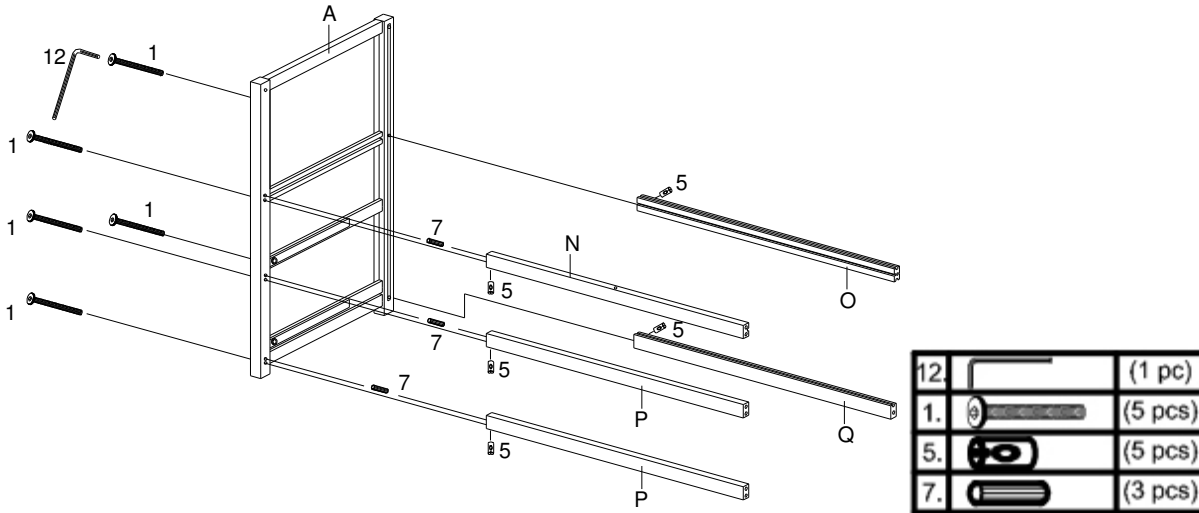

## STEP 2:

Slide Upper Back Panel (R), Shelf (S) and Lower Back Panel (T) into the grooves of the rails.

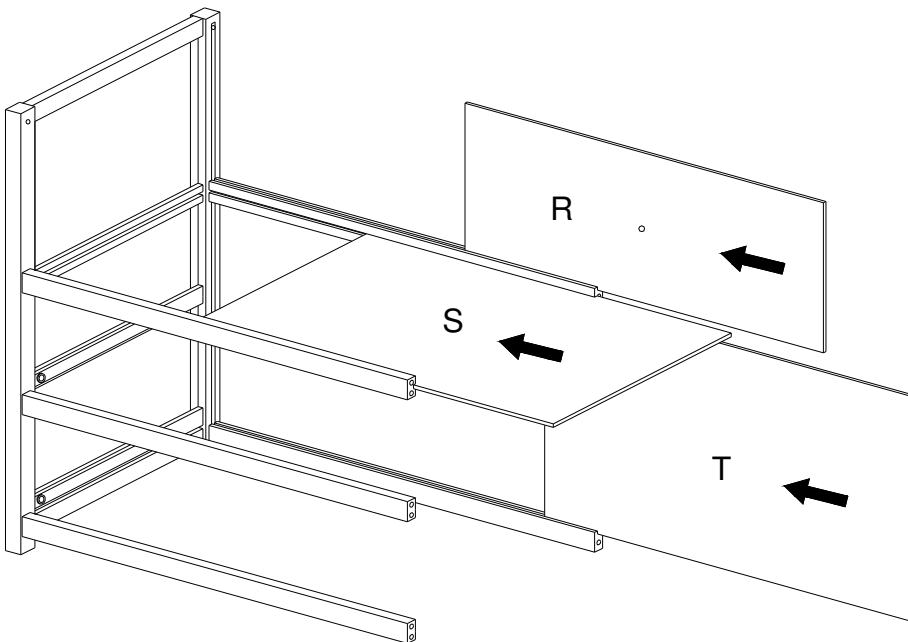

# Changer Assembly Sheet

## STEP 3:

- a. Insert 3 Dowels (#7) into top holes on ends of Front Shelf Rail and Front Drawer Rails.
- b. Attach Right Side Panel (B) to unit by using 5 Barrel Nuts (#5) on the underside of right side of all rails before inserting 5 Bolts (#1). Tighten firmly with Wrench (#12).

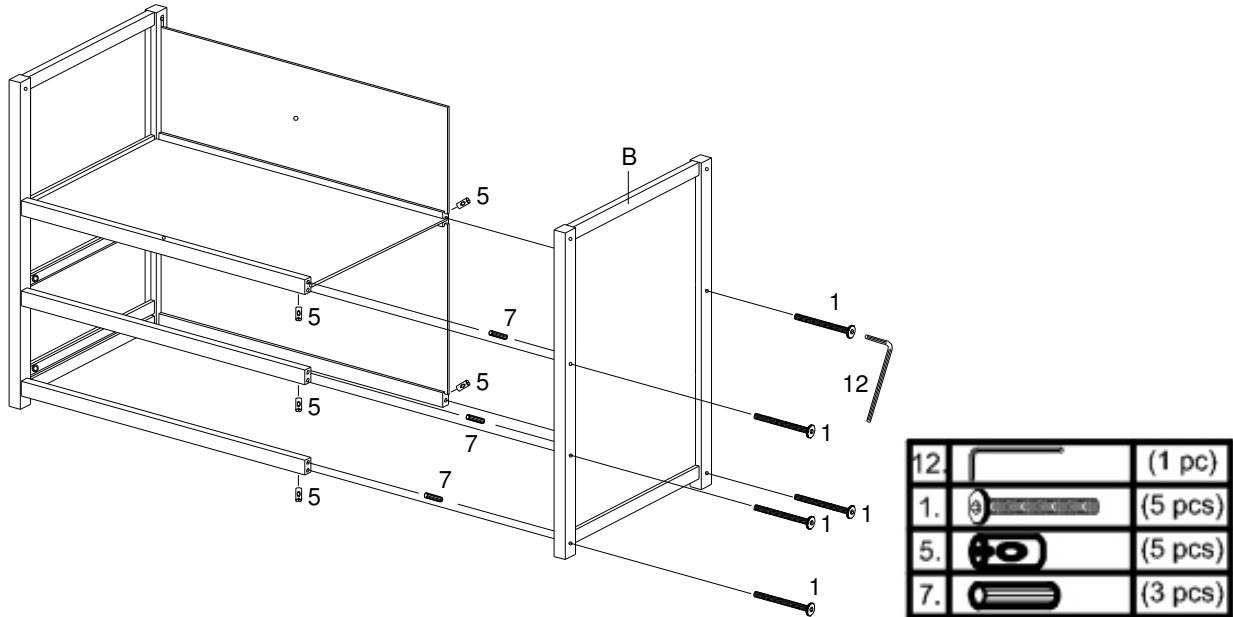

## STEP 4:

- a. Insert Dowel (#7) into Shelf Divider (U).
- b. Attach Shelf Divider to Upper Back Panel by using a Barrel Nut (#6) before inserting Bolt (#4). Tighten firmly with Wrench (#12).

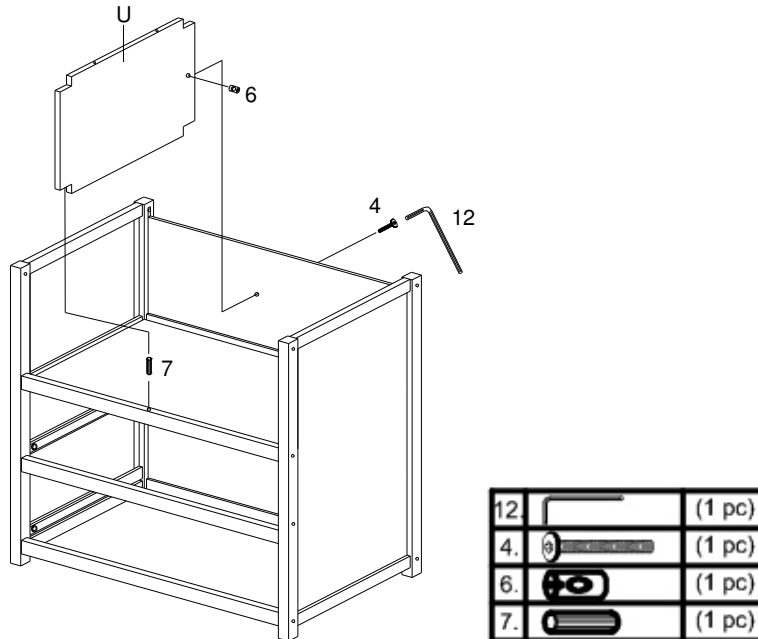

# Changer Assembly Sheet

## STEP 5:

Insert Dowels (#7) into Shelf Divider (U) before attaching changer top to the unit.

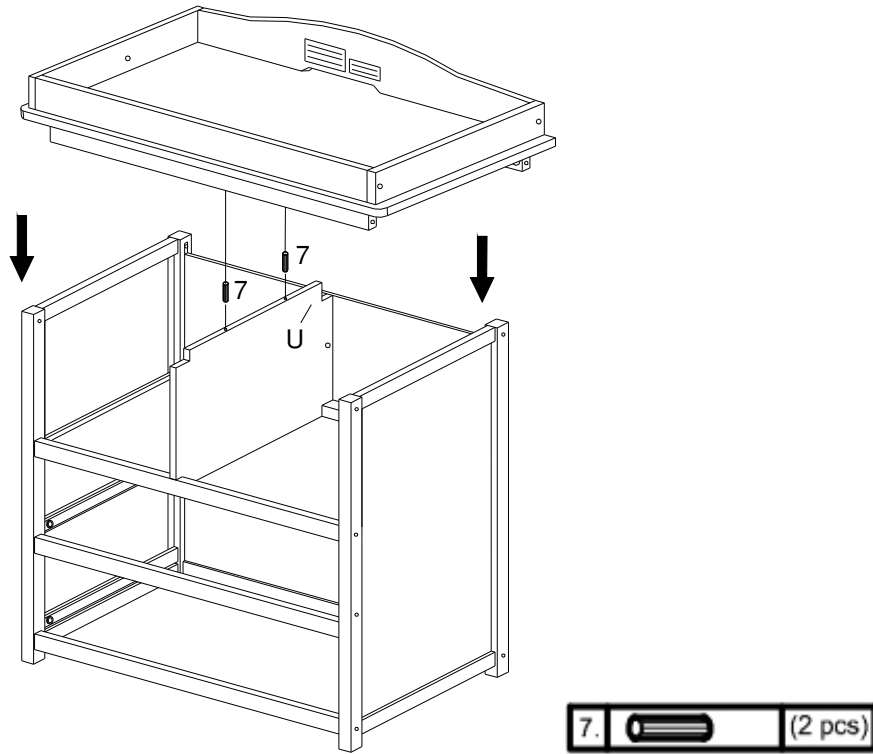

## STEP 6:

- Secure changer top by using Barrel Nuts (#5) before inserting Bolts (#1). Tighten firmly with Wrench (#12).
- Gently rock one side of unit and test for uneven assembly. Retighten screws or reassemble entire unit if necessary.

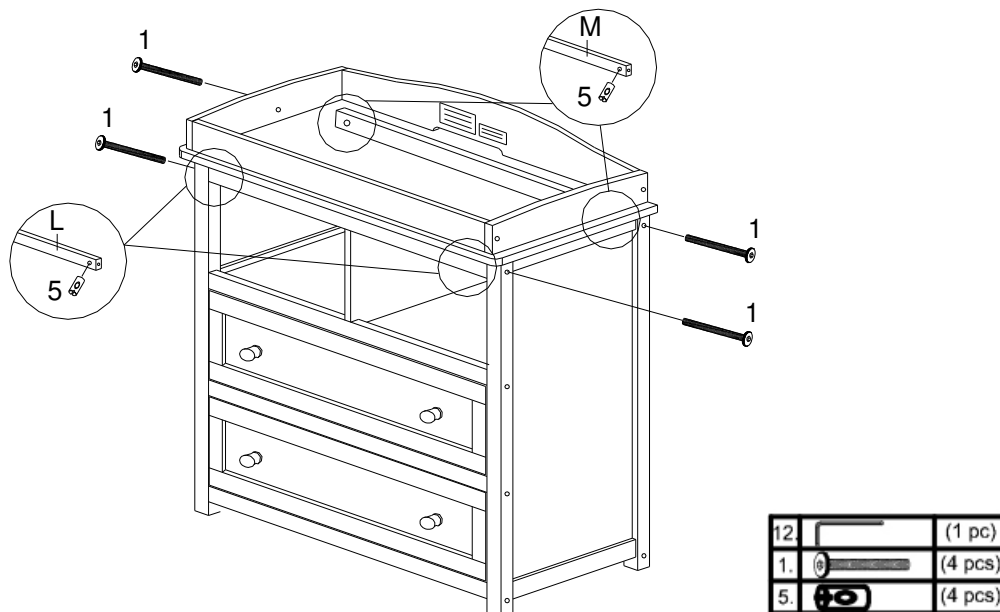

# Changer Assembly Sheet

**STEP 7:**

Slide the drawers inside the changer.

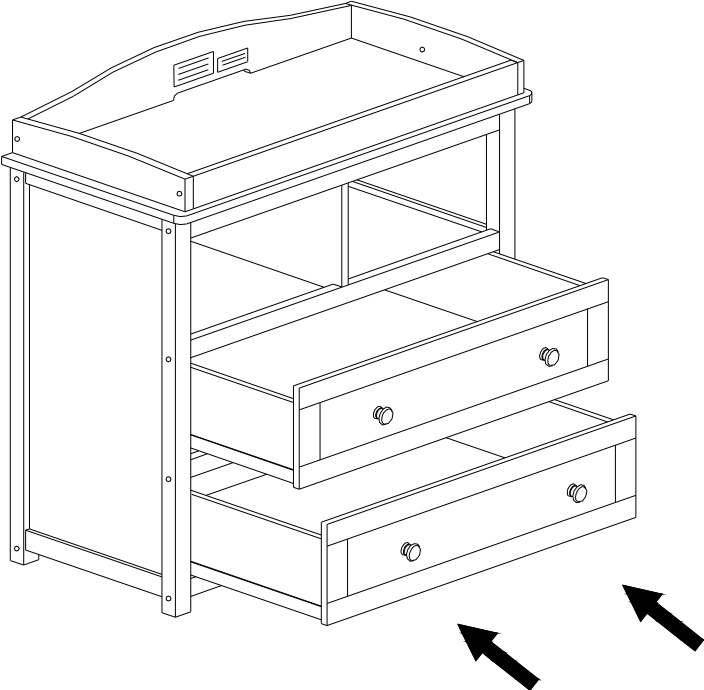

**Changing Table Complete.**







# Wall Safety Strap

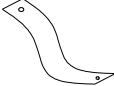

• **TOOLS NECESSARY: RUBBER MALLET, PHILLIPS SCREW DRIVER.**  
**WARNING: WHEN UPRIGHT, IT IS POSSIBLE THAT THE FURNITURE MAY TIP OVER. FOR YOUR CHILD'S SAFETY, PLEASE INSTALL THE SAFETY WALL STRAP BEHIND THE FURNITURE.**

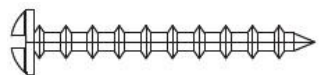
PLEASE READ ALL INSTRUCTIONS CAREFULLY BEFORE USING THIS PRODUCT AND KEEP THESE INSTRUCTIONS FOR FUTURE REFERENCE. IF YOU HAVE ANY QUESTIONS, PLEASE EMAIL US OR VISIT OUR WEBSITE.

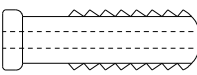
<p>Safety Wall Strap 8" x 1.5" (1 pc)</p> 	<p>Washer (2 pcs)</p> 	<p>Screw D4 x 1-3/8" (1 pc)</p> 
<p>Screw D4 x 3/4" (1 pc)</p> 	<p>Wall Stud (1 pc)</p> 	

**STEP 1:** Make a mark near the top of the back side of the furniture (in the center toward the top frame of the furniture of where you would like to install the safety wall strap). Insert the short screw through the washer and through the safety wall strap. Install the screw into where the mark was made behind the furniture using a Phillips screw driver

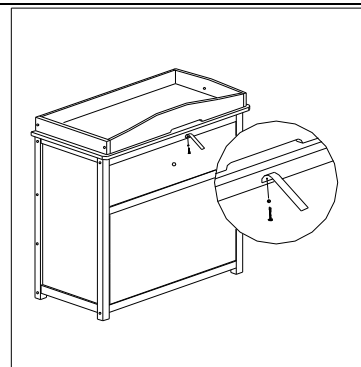

**STEP 2:** Locate a wall stud. With the back of the furniture against the wall, locate the middle of the top of the dresser and make a mark against the wall. Measure 5cm down from the mark and drill a 1/8" pilot hole through the wall stud and into the plaster wall.

**CAUTION:** The changer unit must be centered on a wall stud as shown. If you are unsure of how to locate the wall stud, contact a professional contractor.

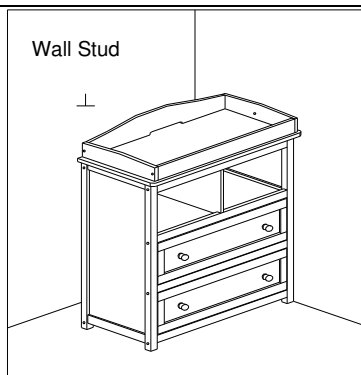

**STEP 3:** Attach the wall strap to the wall stud using the long 1-1/2" screw and washer as shown. Make sure strap holds steady and complete installation.

**CAUTION:** Do not attempt to screw into the plaster wall only. You must also screw into a wall stud.

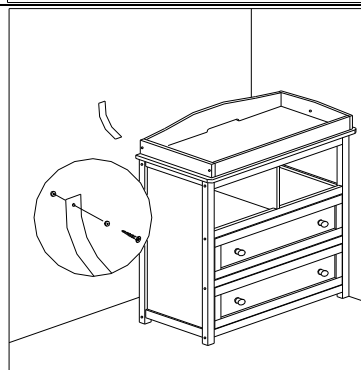

## **One year limited warranty**

We want you to be satisfied with any product that bears our name or logo. We will provide promptly, at the request of the retailer, and without charge, any missing parts that have been reported, with proper description, within 7 days of the purchase of the products. Our warranty guarantees optimal workmanship and lack of significant defects. The product warranty lasts a year from the date of your purchase. Please keep the original receipt so that we may process your one year limited warranty request. This warranty only covers new units with original packaging. Ownership of the warranty is non-transferable. The warranty does not cover any used, second-hand, or demo models. Our obligation under this warranty is to replace or repair the merchandise, at our option, free of charge. This warranty does not cover any damaged or defective parts that result from normal wear and tear, abuse, negligence, improper use or alteration to the finish design, and hardware. Specific rights issued by this warranty may vary from state to state. Some states do not allow limitations on how long implied warranties last. **DO NOT** return products to the store once a product is used, it cannot be resold and the materials and energy invested in the product would go to waste. In the event that we determine that a defect that may result from customer abuse or misuse, we will contact you with information about services and methods to prevent occurrences. We strongly recommend you register your product with our company by filling out registration and mailing it back to us. This ensures you are up-to-date with our products' maintenance and information.

This warranty does not cover damage caused by accident, misuse or any use other than as intended and described in this assembly sheet or damage resulting from failure to maintain and clean this product as specified in this assembly sheet. **This warranty applies only to the original purchaser of our product.**

## **⚠️ CAUTION! Safety Tips for Use of Changers**

**Many older changers, including secondhand or second use changers, may not meet all current safety standards. For baby's safety, even if you are on a tight budget, you should not purchase a used changer at a garage sale or accept a hand-me-down that does not meet the most recent Federal and ASTM standards.**

**Thank you for choosing us.**

**MADE IN VIETNAM**