

---

# ASSEMBLY INSTRUCTIONS

## CHAIR

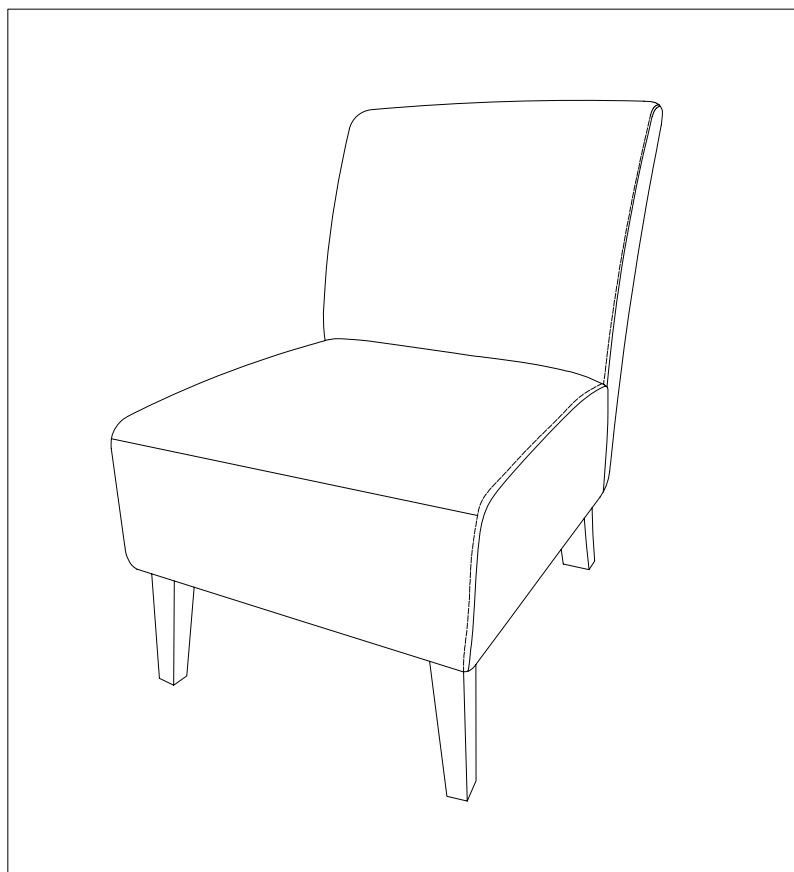

**We are here to help!**

MADE IN CHINA

---

# PARTS IDENTIFICATION

ITEM	DESCRIPTION	QTY
#1	CHAIR SEAT	01
#2	CHAIR BACK	01
#3	BACK LEG	02
#4	FRONT LEG	02

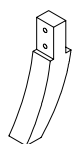
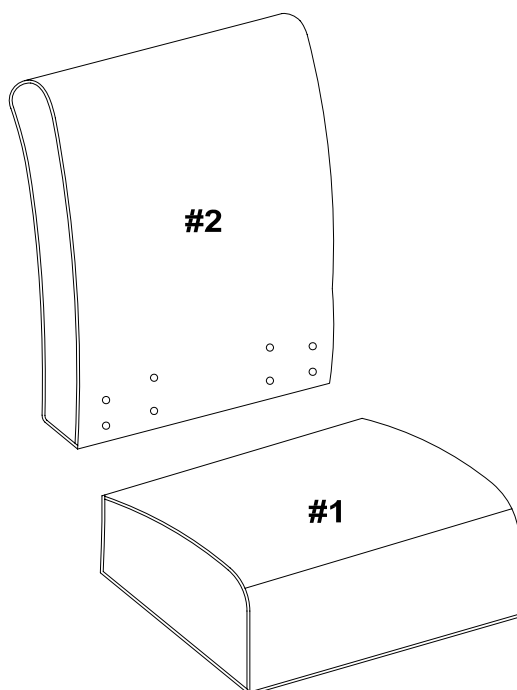

#3

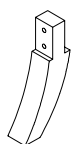

#3



#4





#4

For ease of identification all parts are labeled to correspond to the Step number in which the part is used.

## HARDWARE IDENTIFICATION

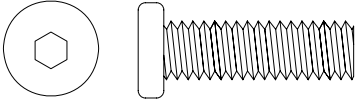
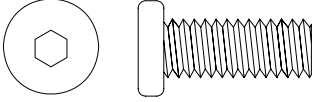
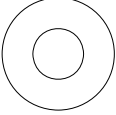
Please line up the hardware with the correct full size image to make sure you are installing the hardware correctly.

ITEM	PICTURE	DESCRIPTION	QTY
<b>A</b>	 (Ø5/16"x2-3/4") Not to Scale	<b>LONG BOLT</b>	<b>02</b>
<b>B</b>	 (Ø5/16"x2") Not to Scale	<b>SHORT BOLT</b>	<b>10</b>
<b>C</b>	 (Ø5/16") Not to Scale	<b>FLAT WASHER</b>	<b>12</b>
<b>D</b>	 (Ø5/16") Not to Scale	<b>SPRING WASHER</b>	<b>12</b>
<b>E</b>	 Not to Scale	<b>ALLEN KEY</b>	<b>01</b>

STEP 1.

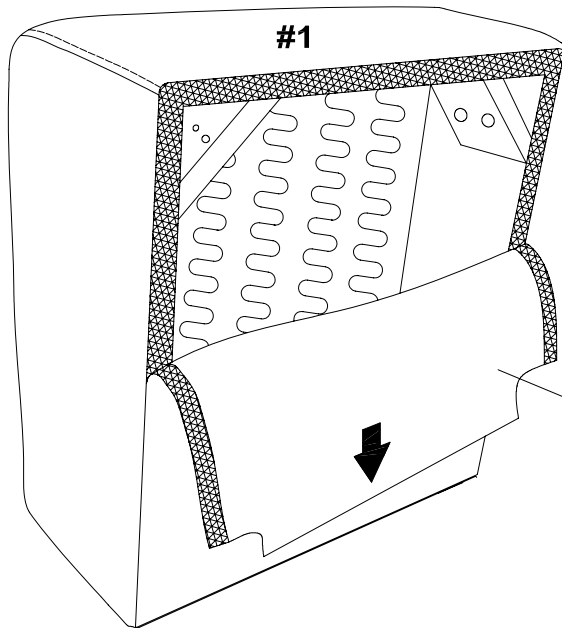

TAKE OFF FABRIC FROM VELCRO BEFORE ASSEMBLING LEGS.

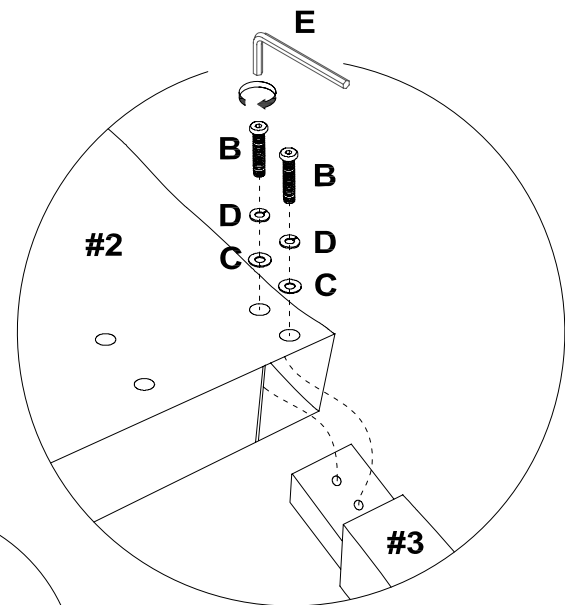

STEP 2.

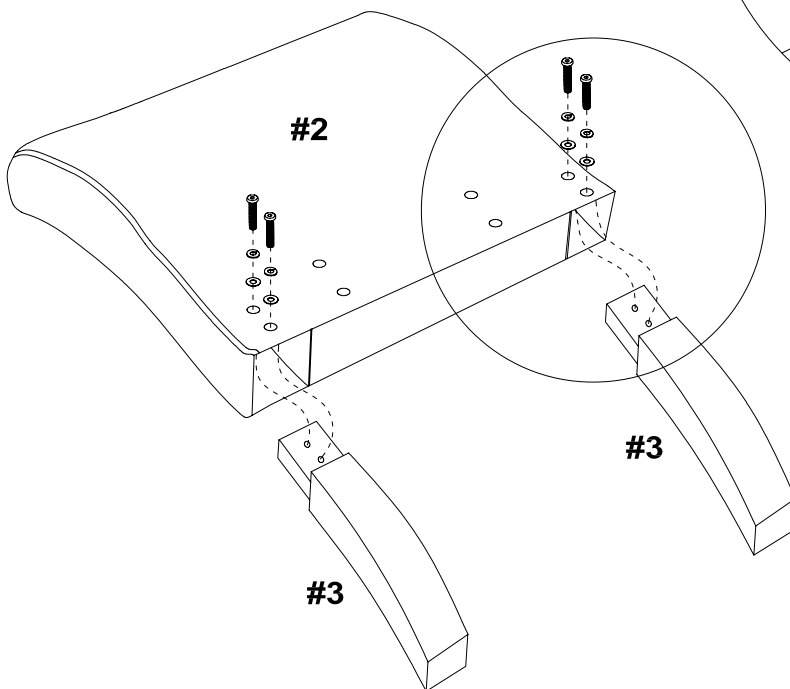

IMPORTANT:

1. DO NOT TIGHTEN BOLTS COMPLETELY UNTIL ALL BOLTS ARE COMPLETELY LINED UP AND INSERTED INTO HOLES / NUTS.
2. DO NOT OVER TIGHTEN SCREWS AND BOLTS TO AVOID STRIPPING.

STEP 3.

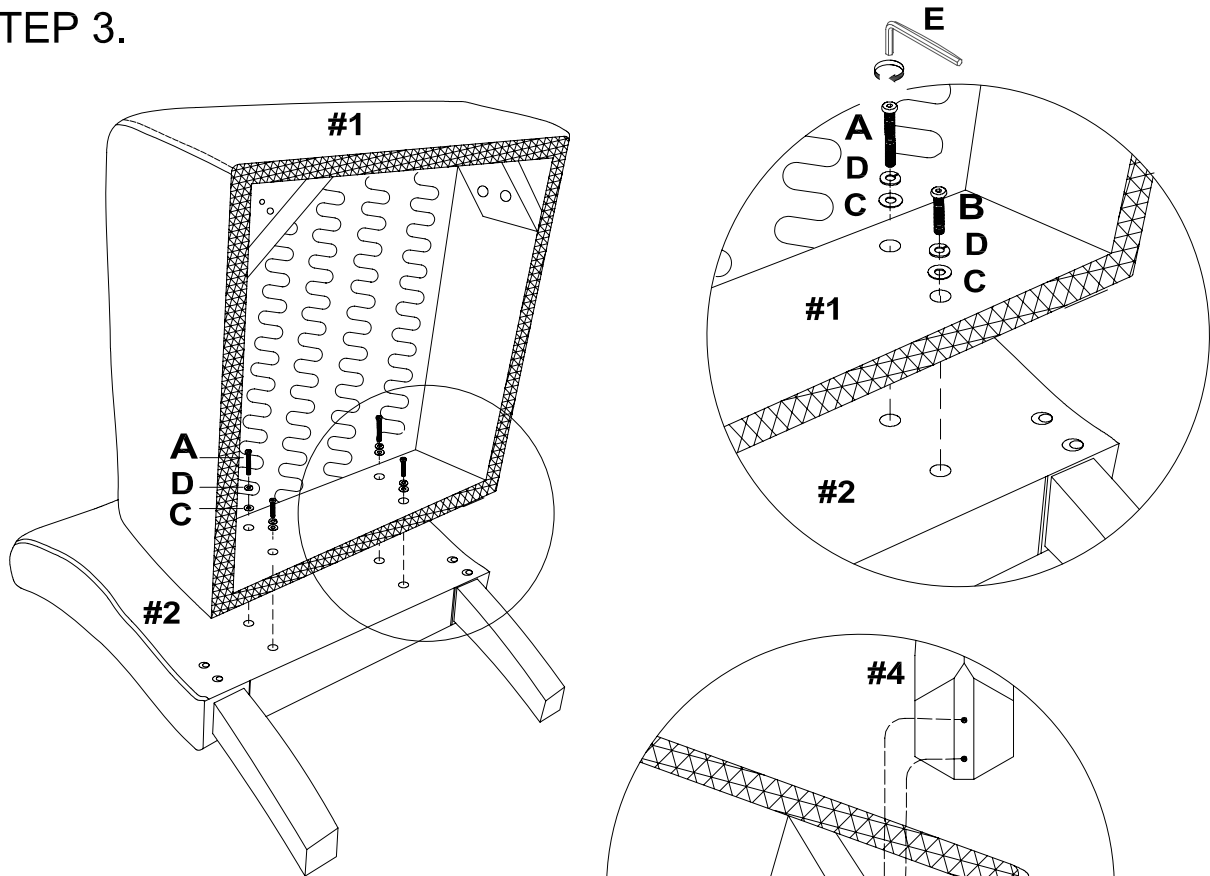

STEP 4.

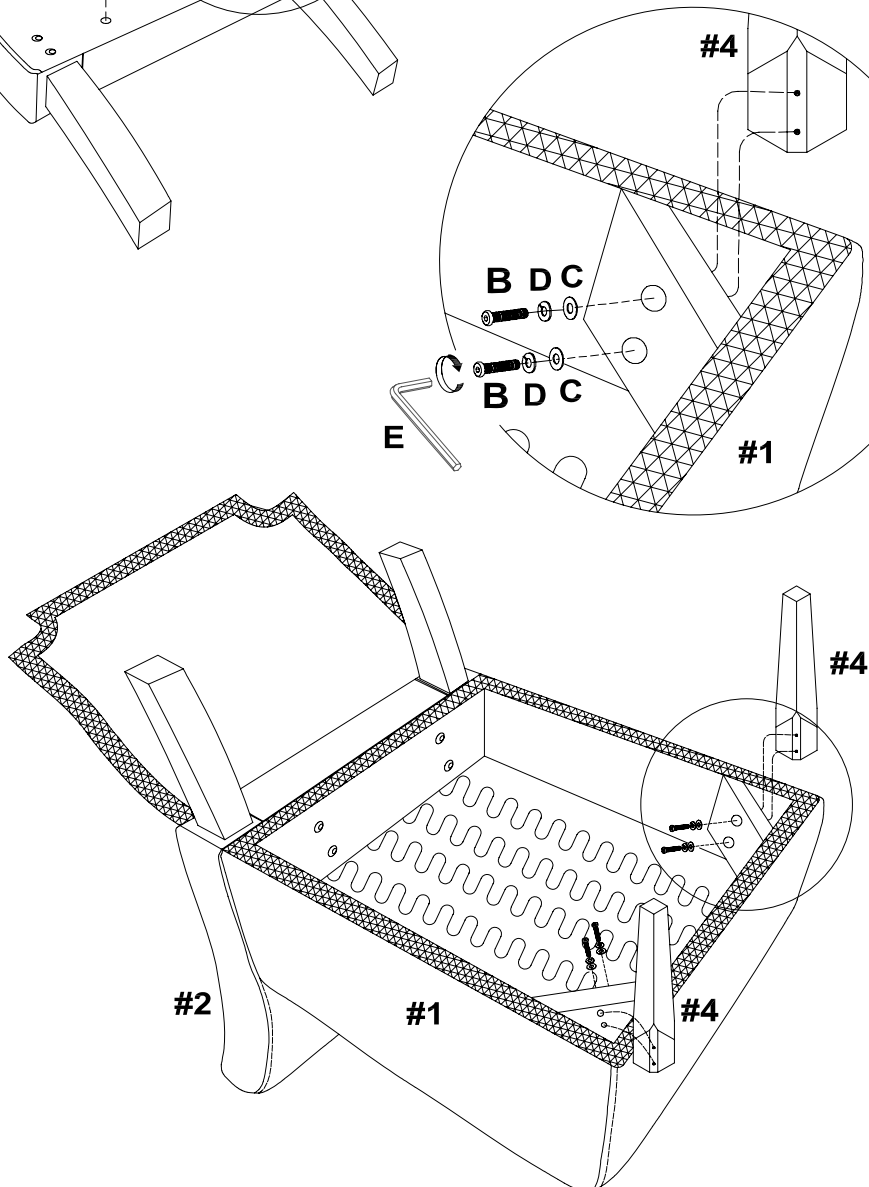

**STEP 5.**

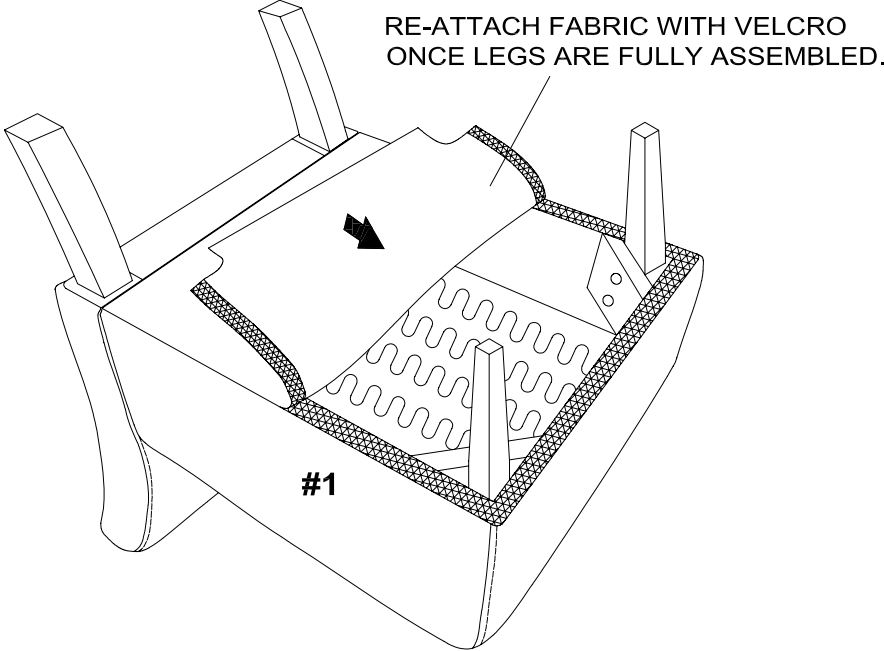

**STEP 6.**

**Weight Limit 275LBS**

