

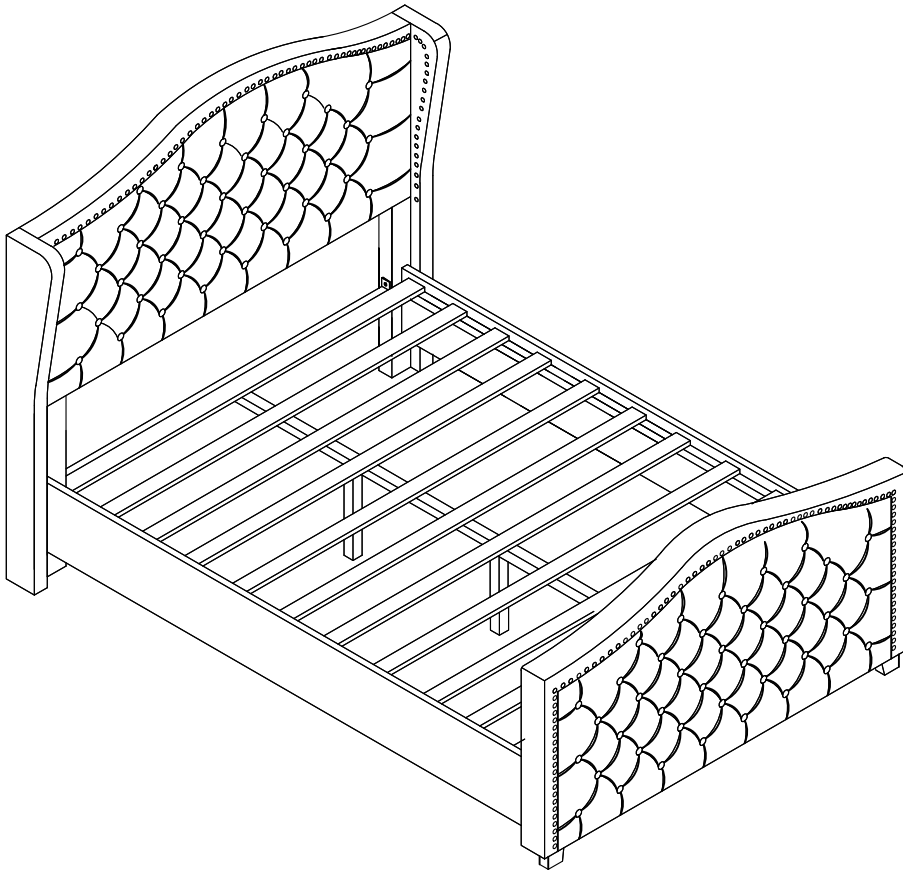









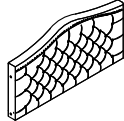

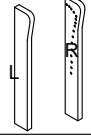

# ASSEMBLY INSTRUCTION

ITEM NO: 510&520&530-QUEEN

**IMPORTANT: PLACE ALL PARTS ON A CLEAN AND SMOOTH SURFACE SUCH AS A RUG OR CARPET TO AVOID THE PARTS FROM BEING SCRATCHED**  
**KINDLY FOLLOW THE ASSEMBLY INSTRUCTIONS STEP**  
**DO NOT TIGHTEN ALL SCREWS UNTIL THE BED IS FULLY SET-UP**

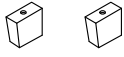

## Bed is packed in 2 carton

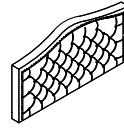
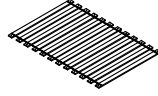
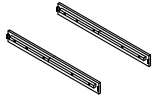
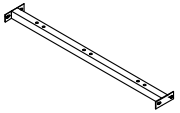
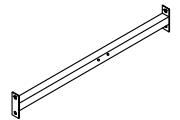
| Carton | Disignation         | Part  | Hardware  |
|--------|---------------------|---|---|
| (1/2)  | 1.Headboard         |    |  #A x 1PC<br> #B x 14PCS<br> #C x 18PCS<br> #D x 2PCS |
|        | 4.Wingback(2pcs)    |    |  #E x 50PCS<br> #F x 10PCS<br> #G x 28PCS  |
|        | 5.HB Leg(2pcs)      |    |  #H x 24PCS<br> #I x 8PCS<br> #J x 1PC   |
|        | 6.FB Feet(2pcs)     |    |   |
|        | 7.Support Leg(3pcs) |    |   |
|        | 2.Footboard         |   |   |
|        | 7.Slats(12pcs)      |  |   |
| (2/2)  | 3.Side rail(2pcs)   |  |   |
|        | 8.Support rail(1pc) |  |   |
|        | 9.Crossband         |  |   |

STEP 1

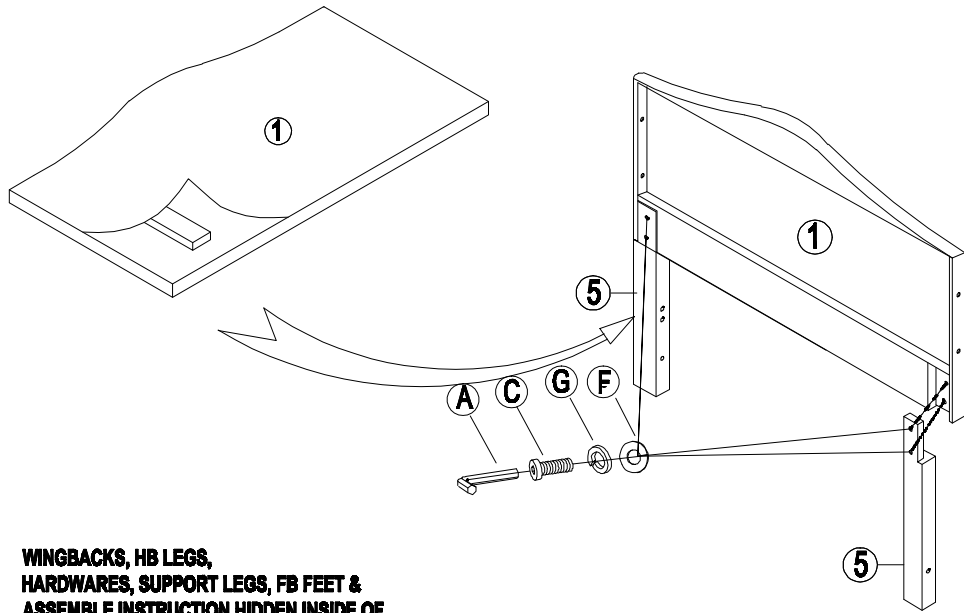

WINGBACKS, HB LEGS,  
HARDWARES, SUPPORT LEGS, FB FEET &  
ASSEMBLE INSTRUCTION HIDDEN INSIDE OF  
THE HEADBOARD, PLZ LIFT THE COVER .

STEP 2

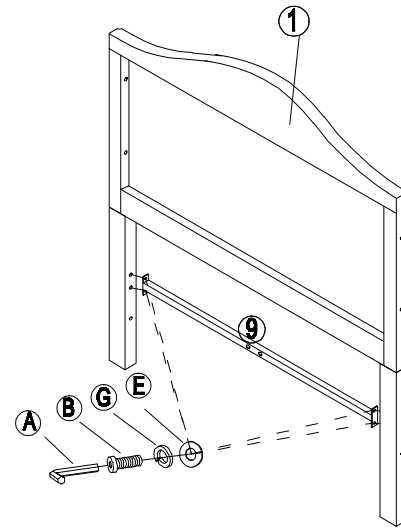

STEP 3

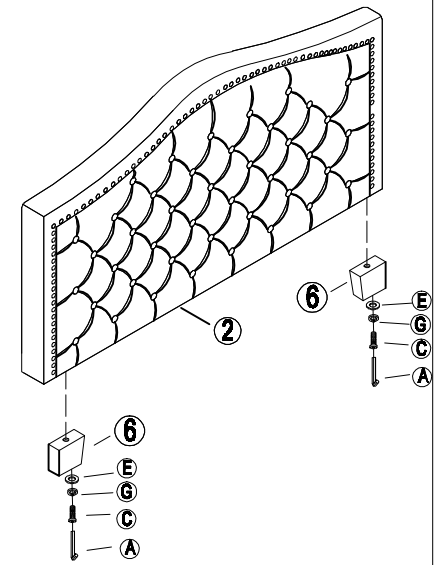

STEP 4

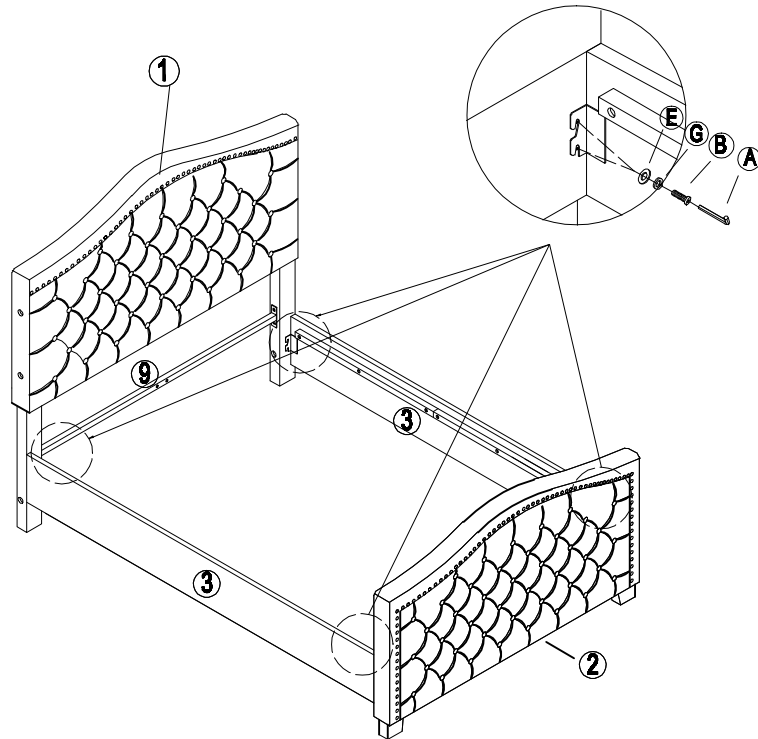

STEP 5

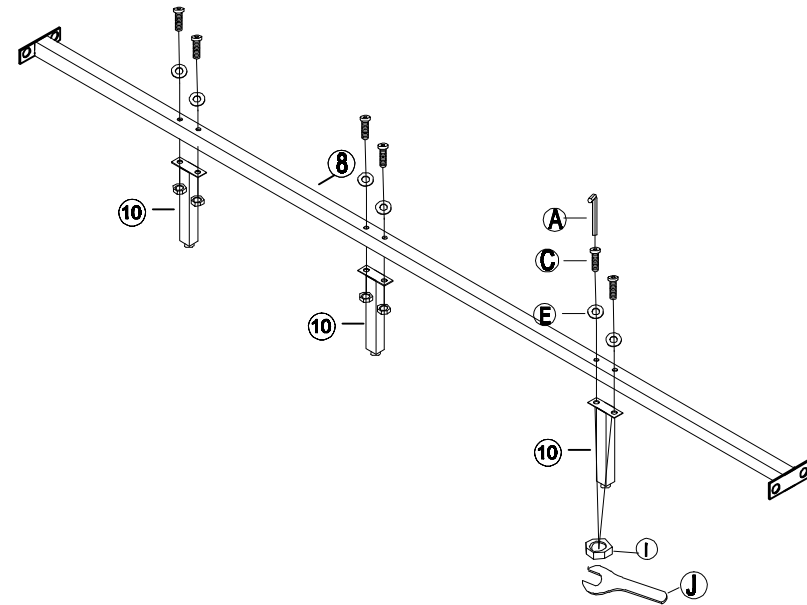

STEP 6

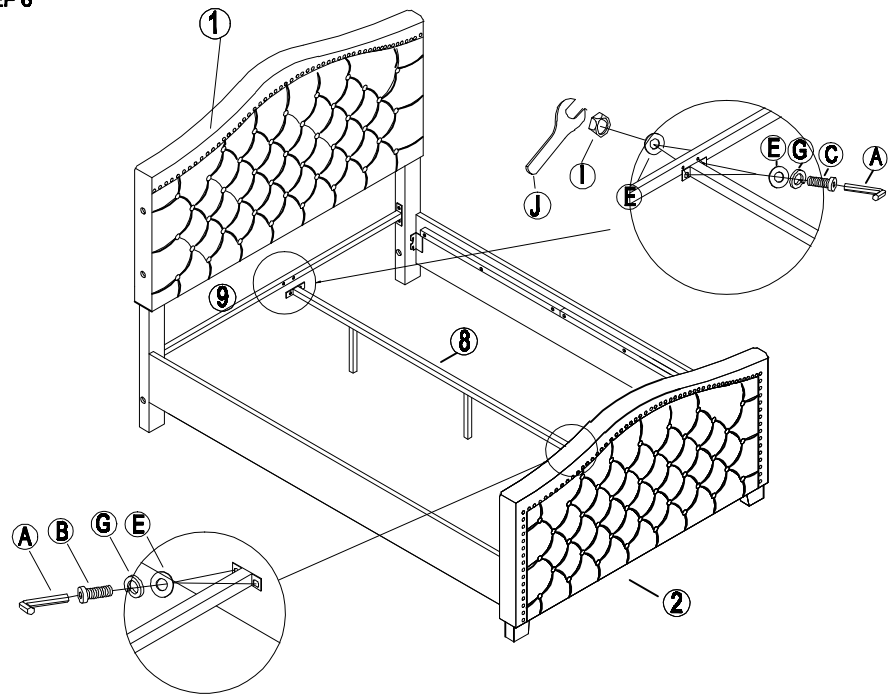

STEP 7

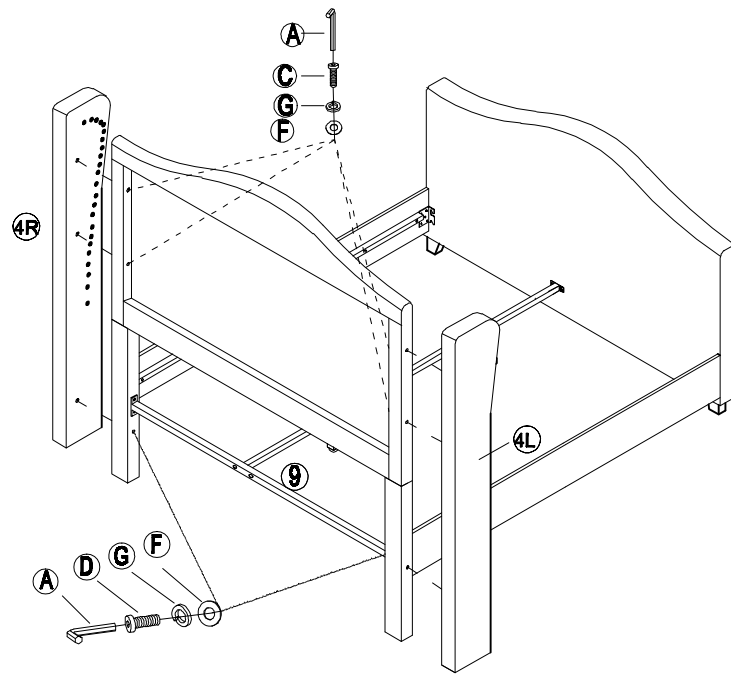

STEP 8

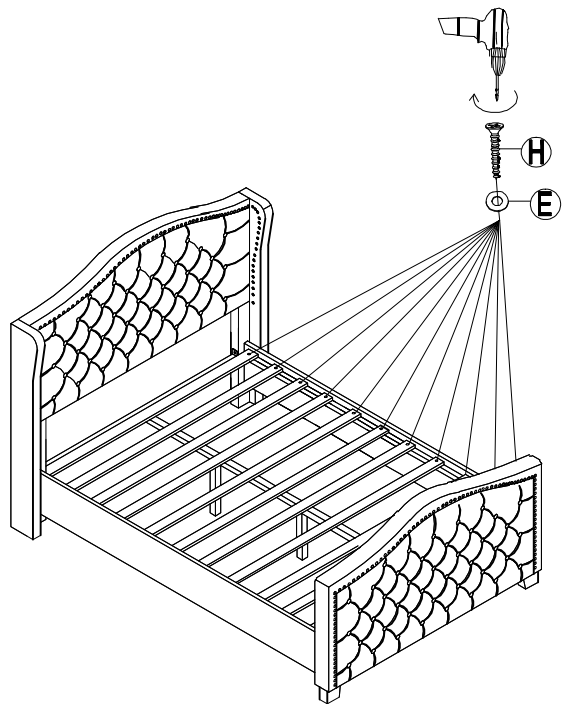

STEP 9

