

## NOTICE

- \* Please make sure that you have all parts indicated and they are in good condition before you begin assembly of this item. Refer to part list and hardware list below for guidance.
- \* This item should be assembled on a soft surface to prevent scratching the finish during assembly.
- \* This item may require periodic tightening.

## PREPARATION















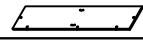

- \* Before beginning assembly of product, make sure all parts are present. Compare parts with part contents list and hardware contents list.
- \* If any part is missing or damaged, do not attempt to assemble the product.
- \* Estimated Assembly Time: 60 minutes.
- \* Tools Required for Assembly: Allen Key (included), Phillips screwdriver (not included)

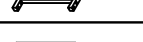
## CARE AND MAINTENANCE

**WOOD CARE:** Objects placed on articles of furniture should rest on non-abrasive material as to prevent damage to the wood finish. Wipe up spills immediately and avoid common hazards such as hot dishes, harsh solvents and abrasives. Cleaning should be done with a soft lint-free cotton cloth dampened with water or furniture polish.

**METAL CARE:** Wipe spills immediately. Maintain with regular dusting and clean with mild soap and water, dry thoroughly and do not use a brass cleaner. Adhesive felt pads should always be used/applied in order to prevent damage to the furniture or surfaces on which the furniture is placed.

## Part List and Hardware List

PIECE	DESCRIPTION	PICTURE	QTY	CARTON CALL
A	TOP PANEL		1X	1 OF 2
B	LEFT PANEL		1X	2 OF 2
C	RIGHT PANEL		1X	2 OF 2
D	FRAME ASSEMBLY		1X	2 OF 2
E	RAIL		1X	1 OF 2
F	BOTTOM PANEL		1X	1 OF 2
G	UPPER BACK PANEL		1X	1 OF 2
H	LOWER BACK PANEL		1X	1 OF 2
I	LEG FRAME		2X	1 OF 2
J	SIDE FRAME		2X	1 OF 2
K	CENTER FRAME		2X	1 OF 2
L	DRAWER FRONT		6X	1 OF 2
M	DRAWER LEFT		6X	2 OF 2
N	DRAWER RIGHT		6X	2 OF 2
O	DRAWER BACK		6X	1 OF 2
P	DRAWER BASE		6X	2 OF 2
Q	DRAWER SUPPORT		6X	2 OF 2





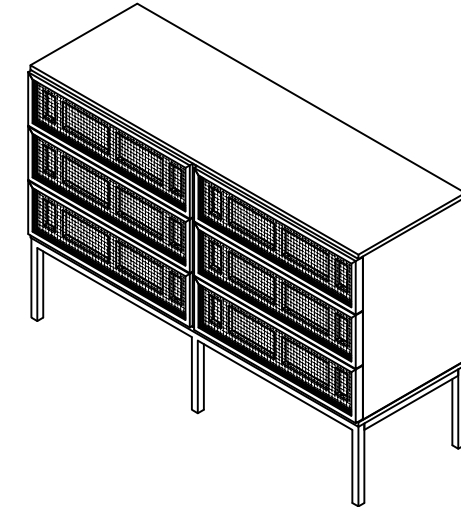





## Installation & Assembly

Product Dimensions: 54"W x 18"D x 36"H



### ⚠ WARNING ⚠

WEIGHT CAPACITY: TOP: 110 LBS, DRAWER: 20 LBS  
 WARNING: DO NOT STAND ON THE DRESSER  
 WARNING: DO NOT OVER TORQUE BOLTS/SCREWS

PIECE	DESCRIPTION	PICTURE	QTY	CARTON CALL
HW1	BOLT 6 x 1 x 45 MM		8X	2 OF 2
HW2	BOLT 6 x 1 x 35 MM		8X	2 OF 2
HW3	BOLT 6 x 1 x 20 MM		4X	2 OF 2
HW4	ROUND HEAD SCREW 4 x 1 x 32 MM		1X	2 OF 2
HW5	FLAT HEAD SCREW 3 x 1 x 32 MM		66X	2 OF 2
HW6	FLAT HEAD SCREW 3 x 1 x 19 MM		18X	2 OF 2
HW7	CAMBOLT 7 x 32 MM		34X	2 OF 2
HW8	CAMLOCK 15 x 10 MM		34X	2 OF 2
HW9	DOWEL 10 x 28 MM		6X	2 OF 2
HW10	DOWEL 8 x 28 MM		8X	2 OF 2
HW11	ALLEN KEY 30 x 78 MM		1X	2 OF 2

## PREPARATION

- \* Before beginning assembly of product, make sure all parts are present. Compare parts with package contents list and hardware contents list.
- \* If any part is missing or damaged, do not attempt to assemble the product.
- \* Estimated Assembly Time: 60 minutes.
- \* Tools Required for Assembly: Allen Key (included), Phillips screwdriver (not included)

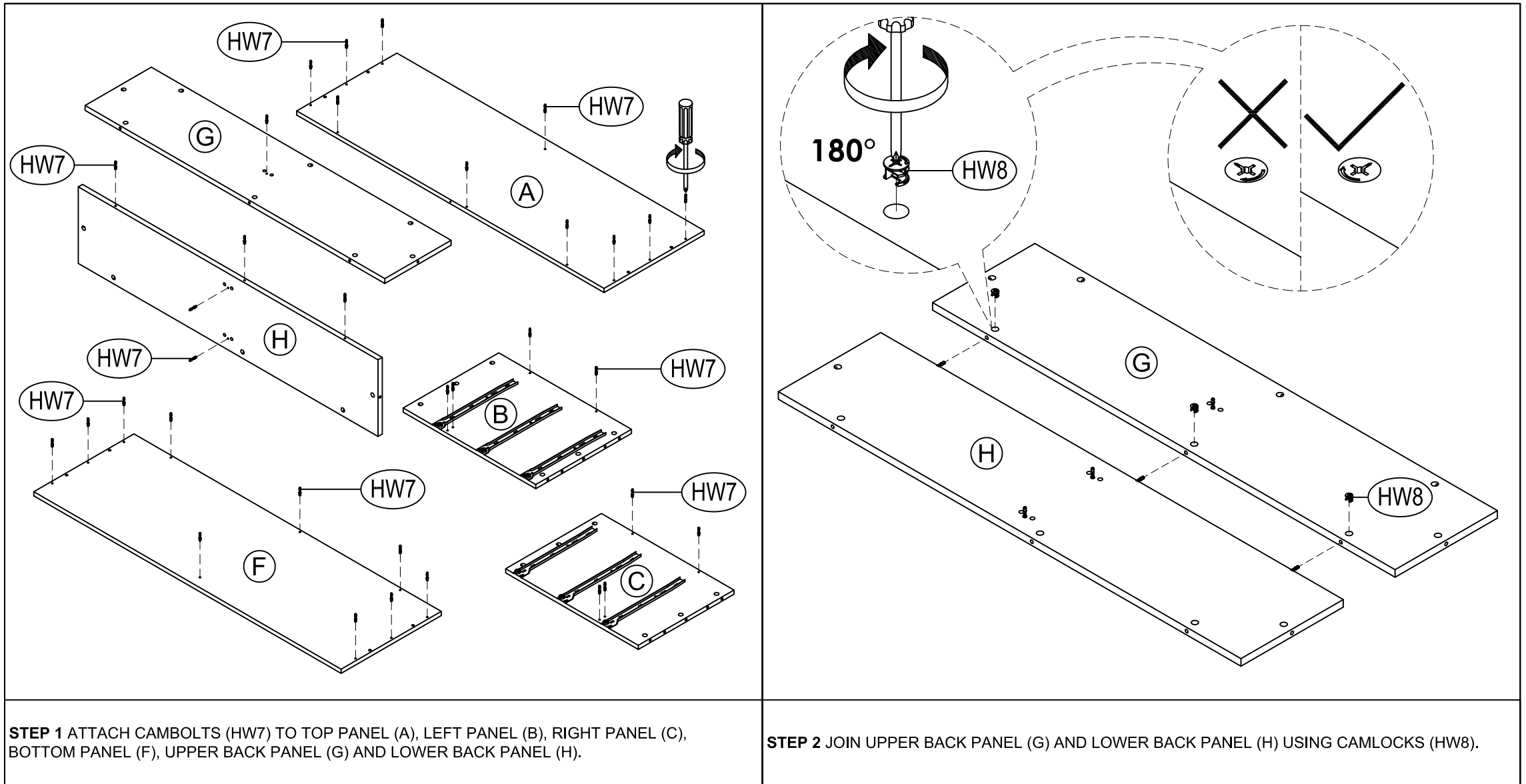

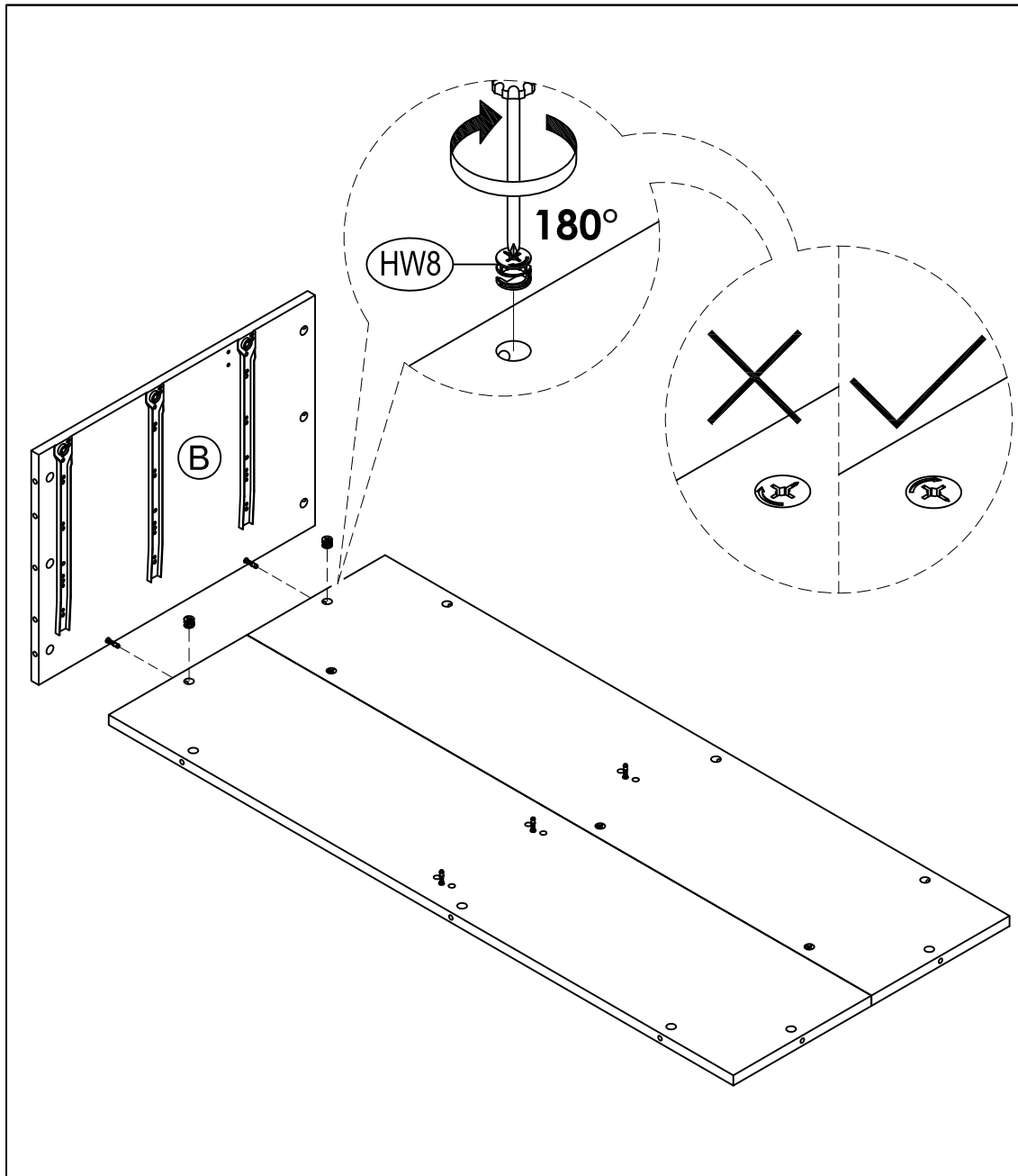

**STEP 3** ATTACH LEFT PANEL (B) TO BACK PANEL ASSEMBLY USING CAMLOCKS (HW8).

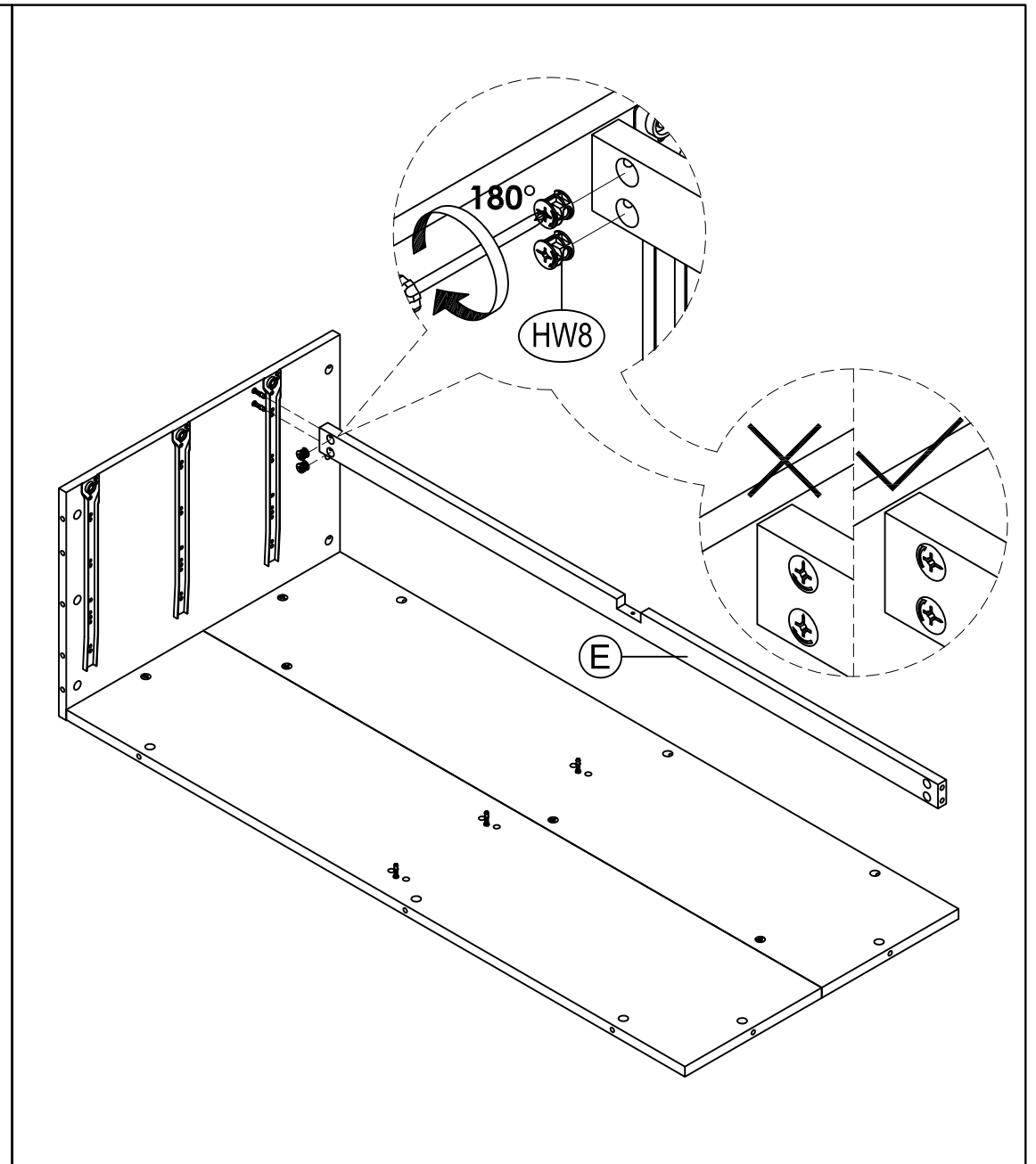

**STEP 4** ATTACH RAIL (E) TO UNIT USING CAMLOCKS (HW8).

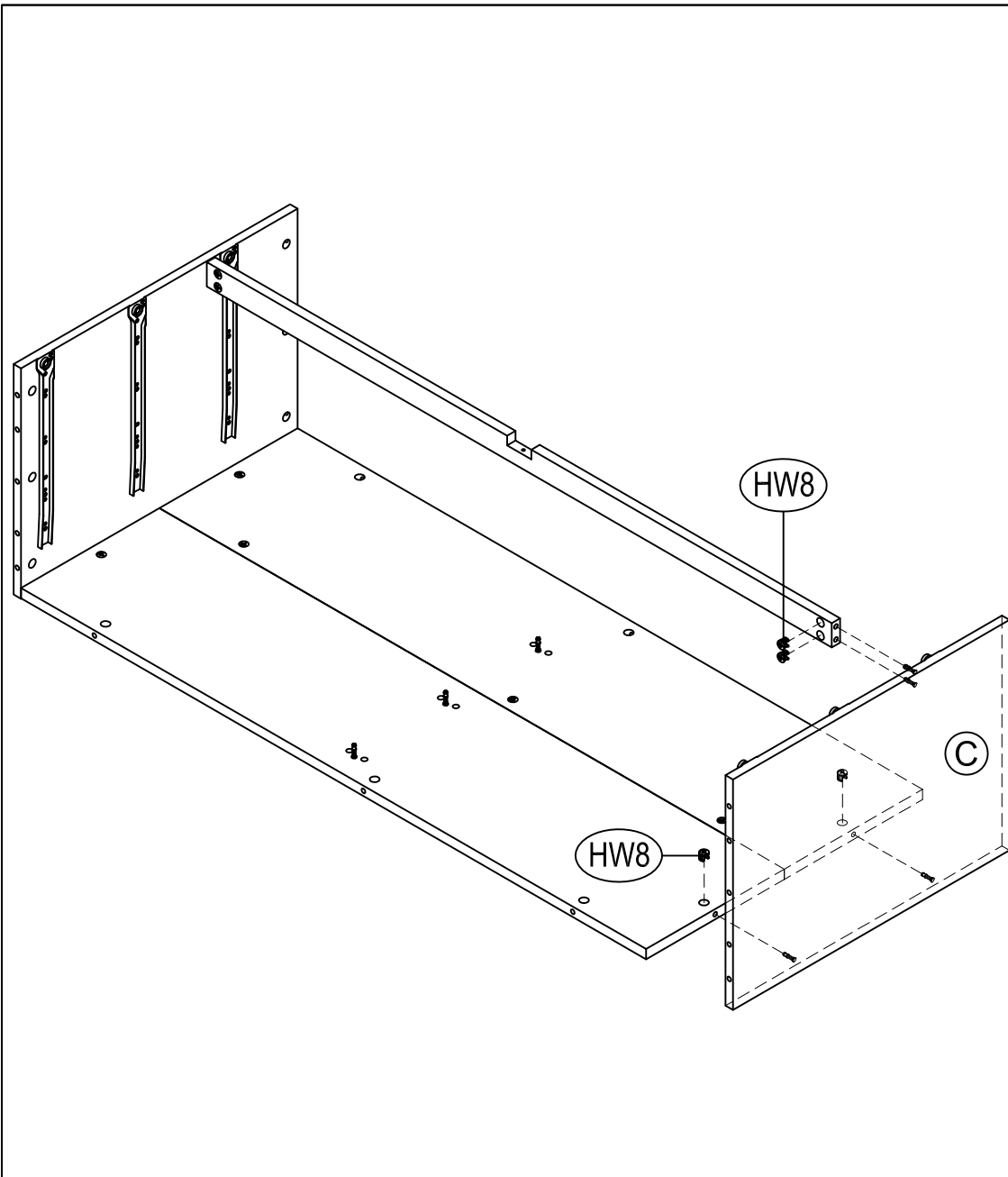

**STEP 5** ATTACH RIGHT PANEL (C) TO UNIT USING CAMLOCKS (HW8).

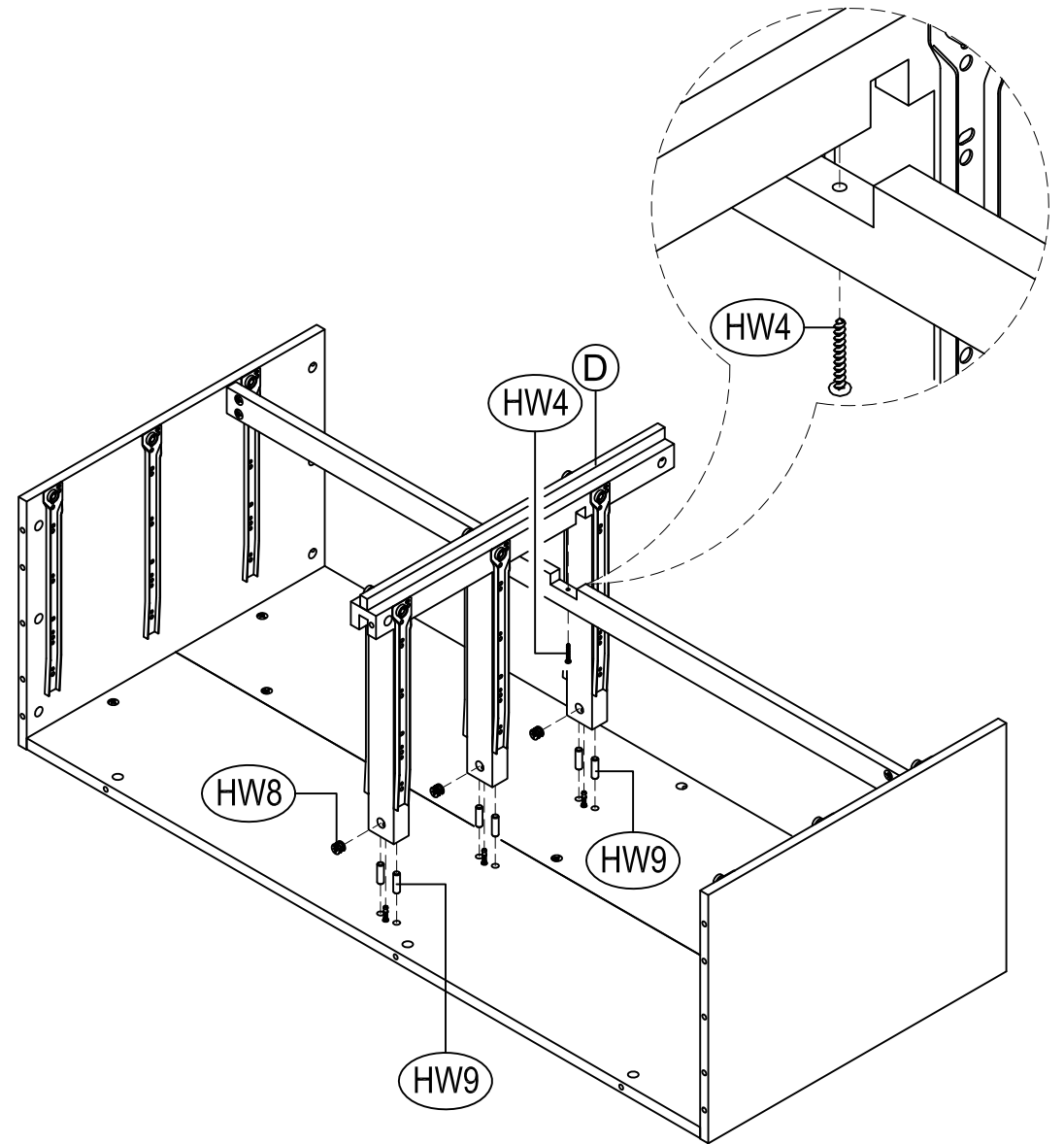

**STEP 6** ATTACH FRAME ASSEMBLY (D) TO UNIT USING CAMLOCKS (HW8),  
Ø10x28 MM DOWELS (HW9) AND 1 1/4" ROUND HEAD SCREW (HW4).

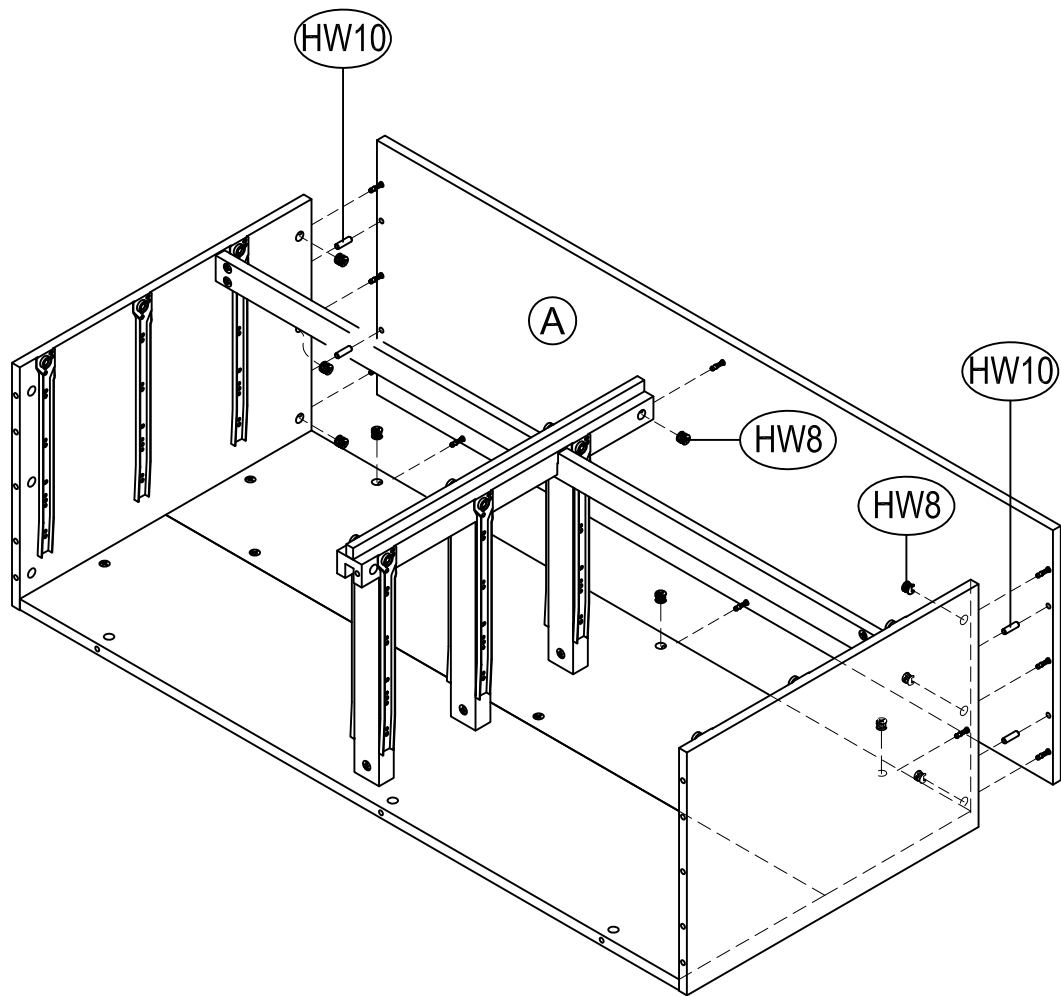

**STEP 7** ATTACH TOP PANEL (A) TO UNIT USING CAMLOCKS (HW8) AND Ø8x28MM DOWELS (HW10).

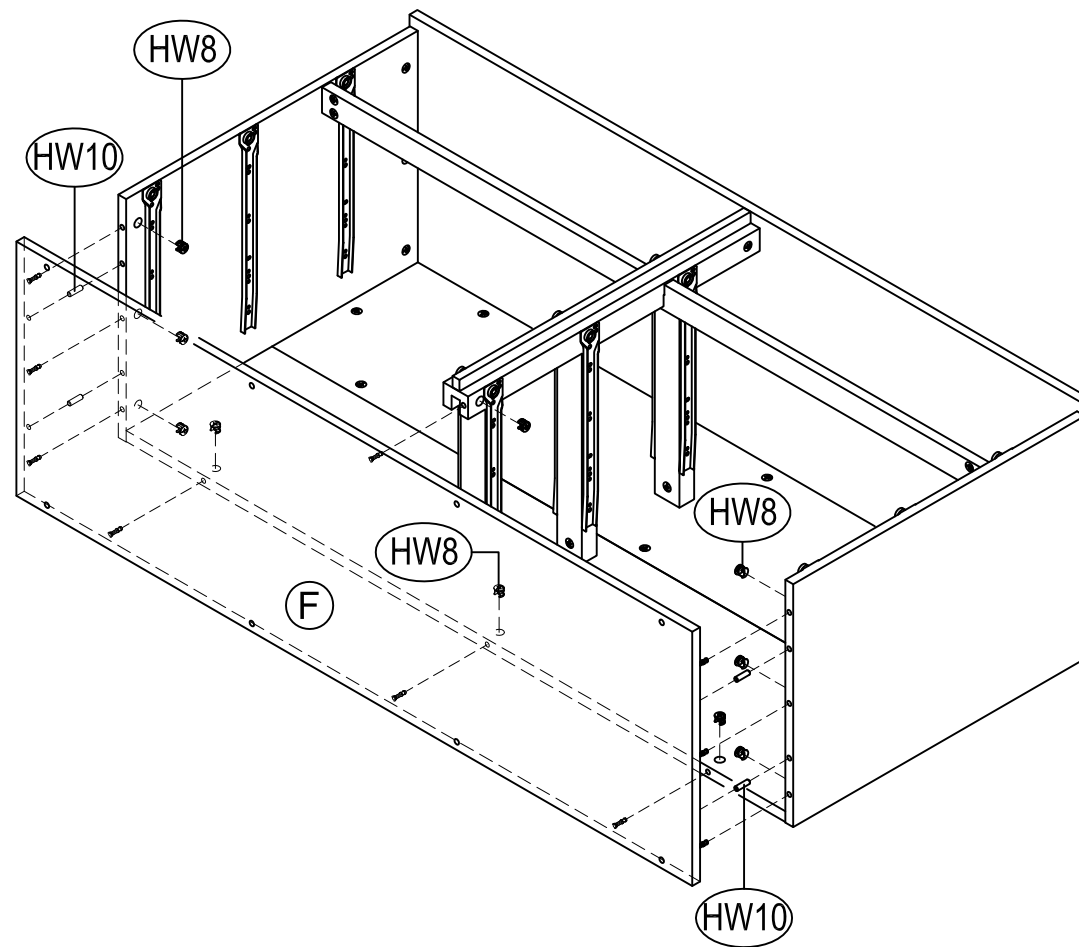

**STEP 8** ATTACH BOTTOM PANEL (F) TO UNIT USING CAMLOCKS (HW8) AND Ø8x28 MM DOWELS (HW10).

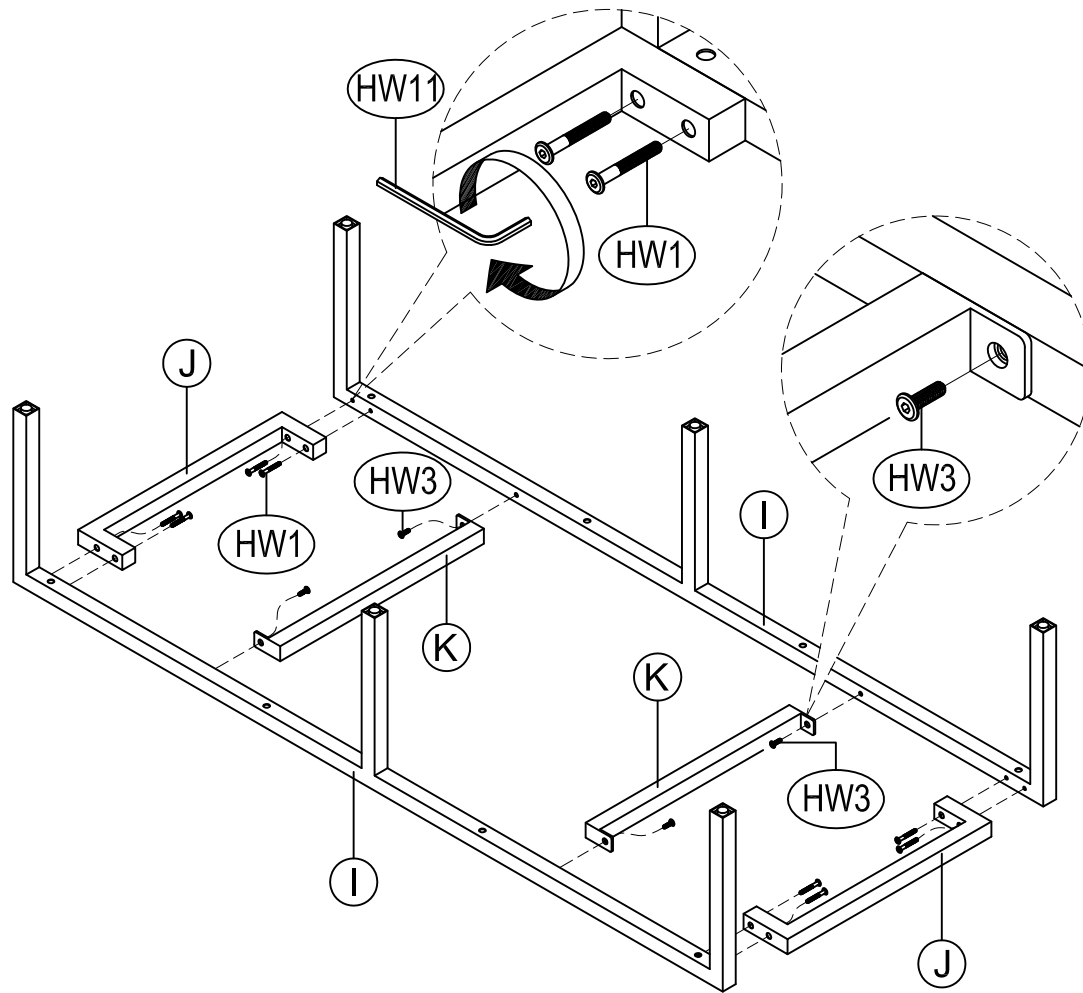

**STEP 9** ATTACH SIDE FRAMES (J) TO LEG FRAMES (I) USING 45 MM BOLTS (HW1).  
 ATTACH CENTER FRAMES (K) TO LEG FRAMES (I) USING 20 MM BOLTS (HW3).  
 TIGHTEN THE BOLTS USING ALLEN KEY (HW11).

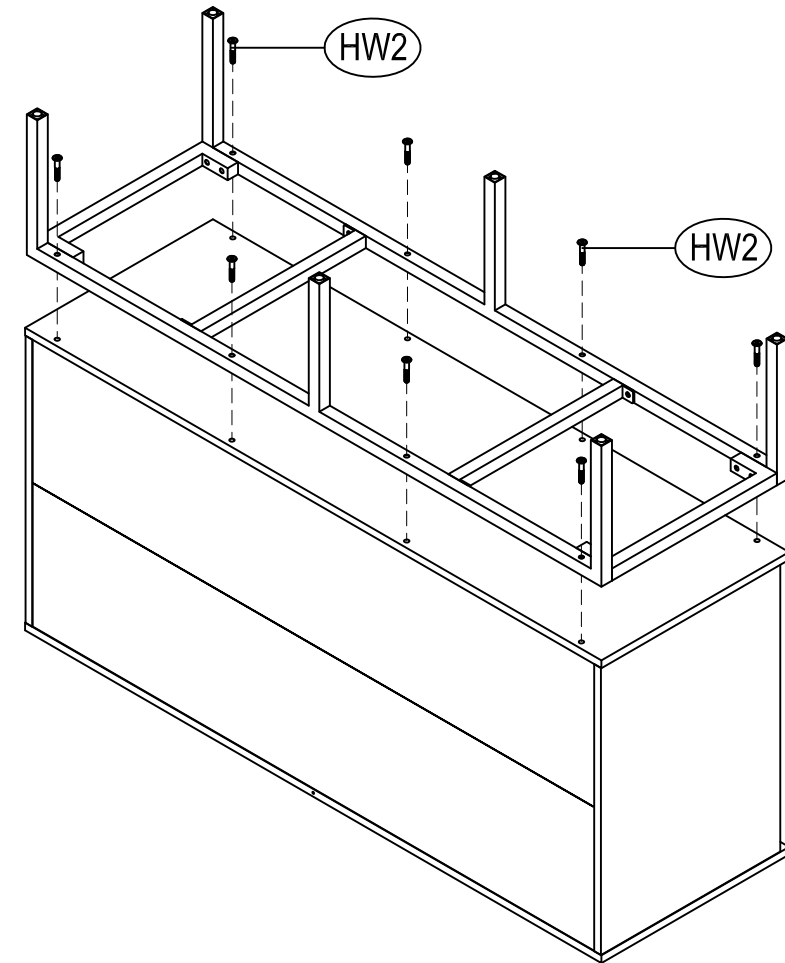

**STEP 10** ATTACH UNIT FROM STEP 9 TO UNIT FROM STEP 8 USING 35 MM BOLTS (HW2).  
 TIGHTEN THE BOLTS USING ALLEN KEY (HW11).

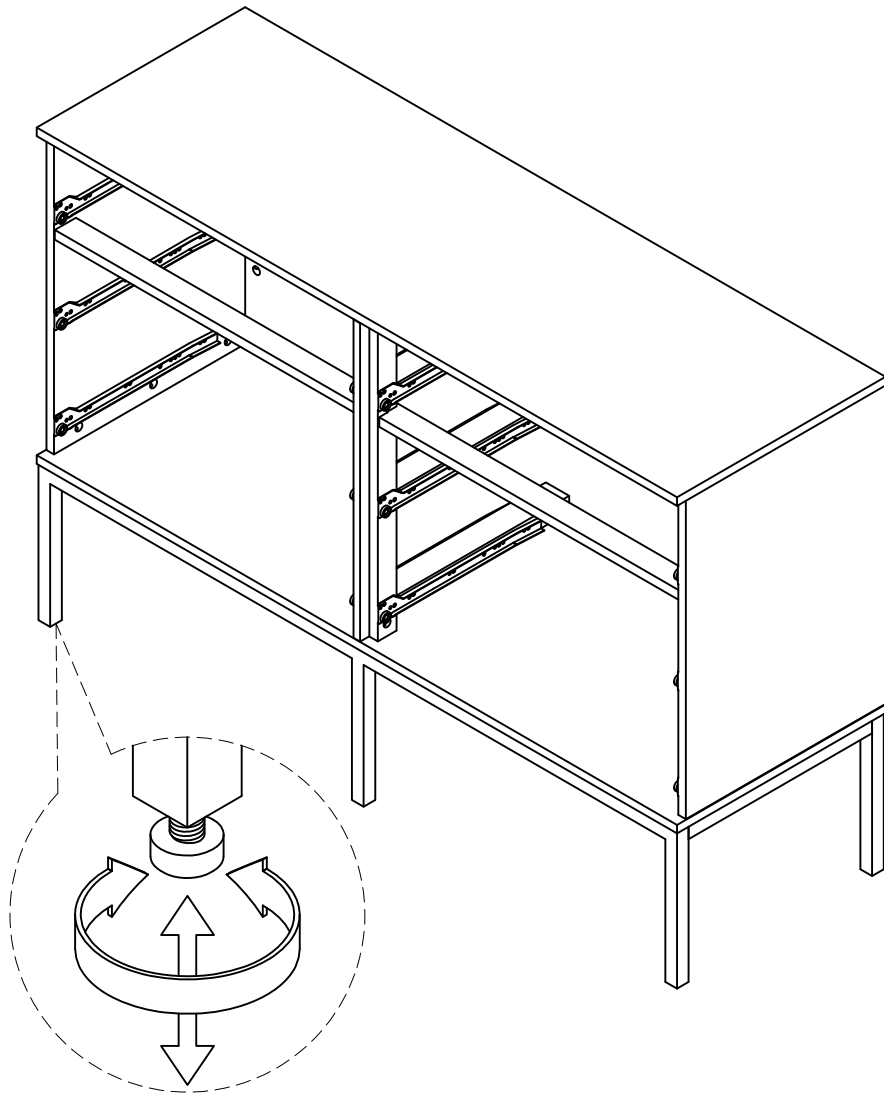

**STEP 11** ADJUST THE ADJUSTER THAT HAS ALREADY BEEN ASSEMBLED TO THE LEGS TO STABILIZE YOUR UNIT.

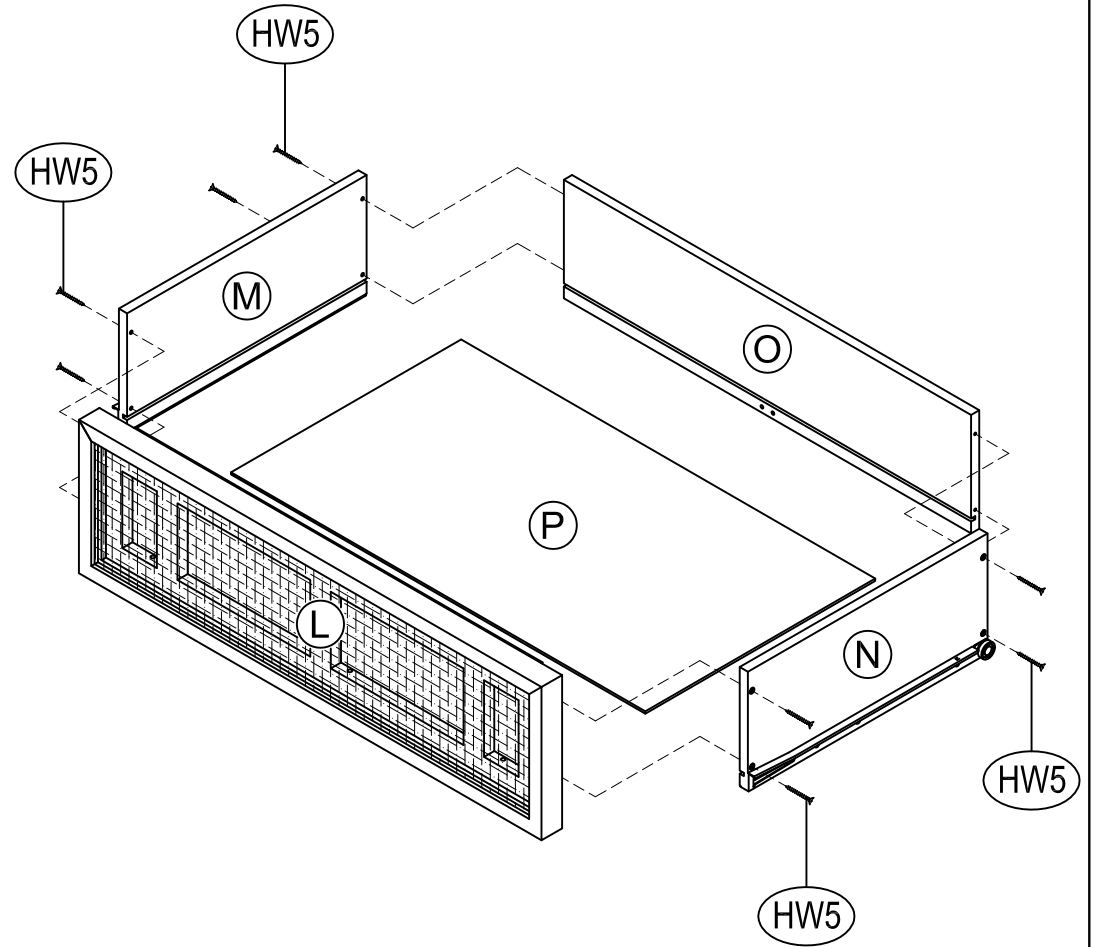

**STEP 12** ATTACH DRAWER LEFT (M) AND DRAWER RIGHT (N) TO DRAWER BACK (O) USING 1 1/4" FLAT HEAD SCREWS (HW5). SLIDE DRAWER BASE (P) INTO THE GROOVE. ATTACH DRAWER FRONT (L) TO DRAWER LEFT (M) AND DRAWER RIGHT (N) USING 1 1/4" FLAT HEAD SCREWS (HW5).

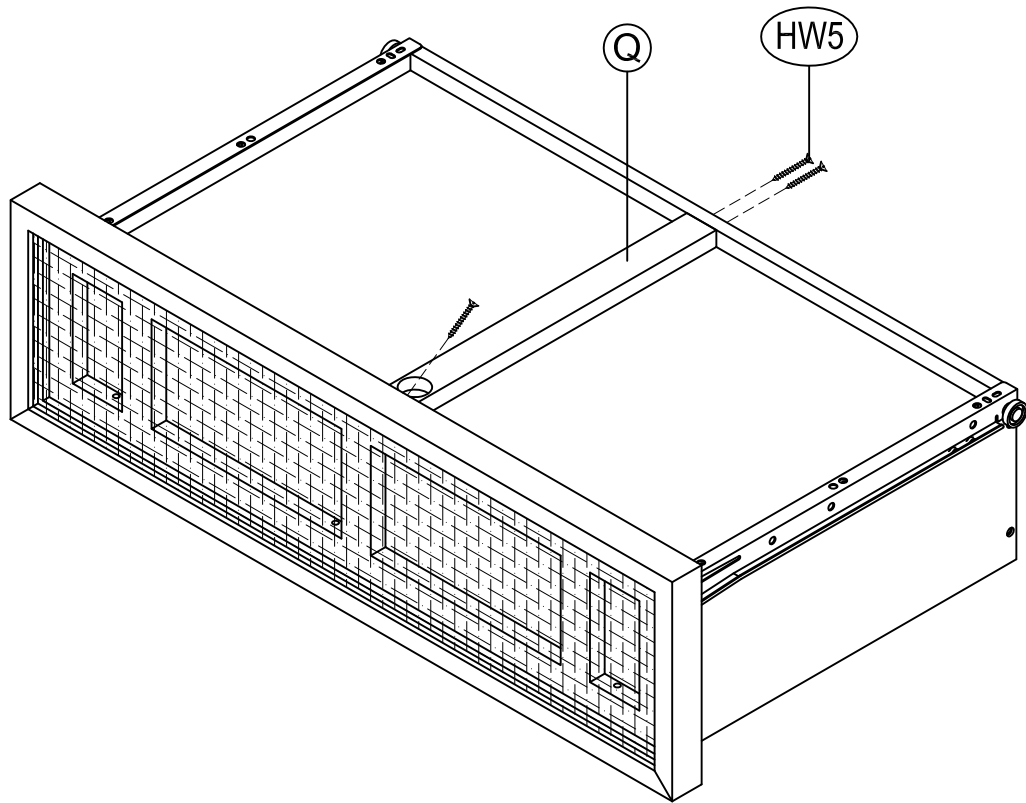

**STEP 13** ATTACH DRAWER SUPPORT (Q) TO THE BOTTOM SIDE OF DRAWERS USING 1 1/4" FLAT HEAD SCREWS (HW5).

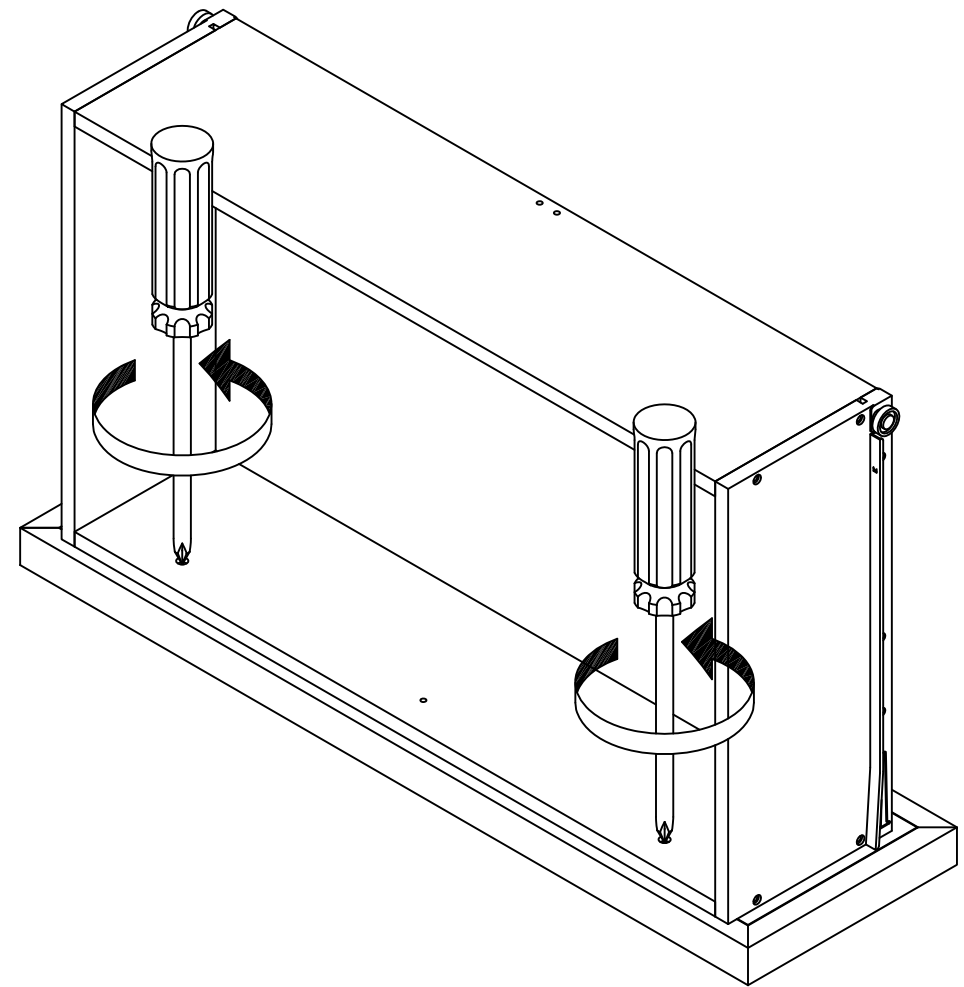

**STEP 14** LOOSEN SLIGHTLY THE SCREWS PRE-INSTALLED ON THE BACK OF THE DRAWER FRONTS.

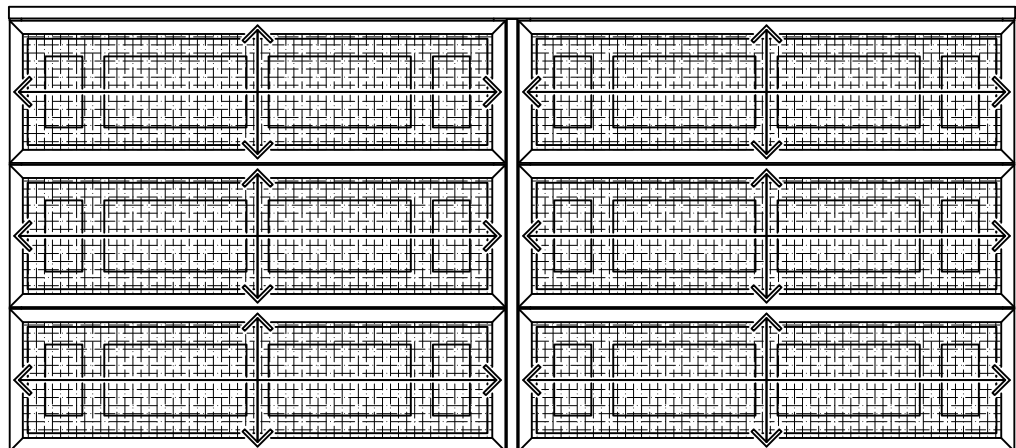

**STEP 15** INSERT THE DRAWER INTO THE UNIT, THEN ADJUST THE DRAWER FRONT PANEL LEFT OR RIGHT AND UP OR DOWN UNTIL THE DRAWER GAPS LOOK PROPORTIONAL.

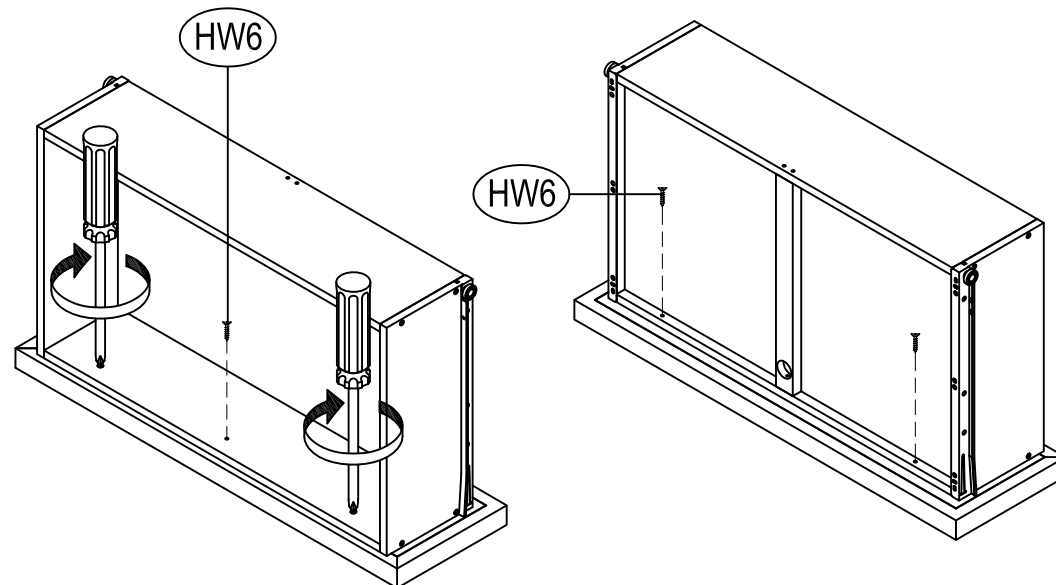

**STEP 16** PULL THE DRAWER OPEN SLOWLY AND RE-TIGHTEN THE SCREWS FROM STEP 14. MAKE SURE THE FRONT PANEL DOES NOT MOVE AND LOCK THE DRAWER FRONT PANEL INTO POSITION WITH 3/4" FLAT HEAD SCREWS (HW6).

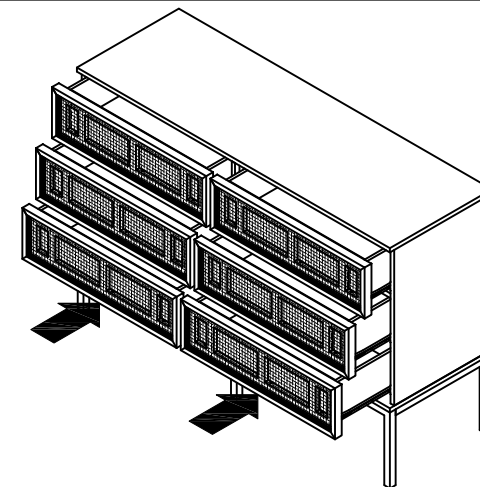

**STEP 17** SLIDE THE DRAWERS INTO UNIT.