

PENDANT LIGHT (ROD) Assembly Instructions

MODEL#: 8217PL-06GD-US

CAUTION

- Inspect the wire insulation for any cuts, abrasions, or exposed copper that may have resulted during shipping. If there is a defect in the wire, do not attempt installation.
- Before starting installation of this fixture or removal of a previous fixture, disconnect the power by turning off the circuit breaker or by removing the fuse at the fuse box.

TOOLS REQUIRED

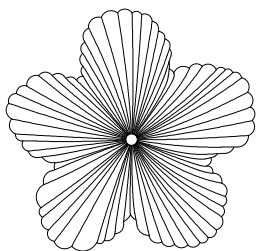
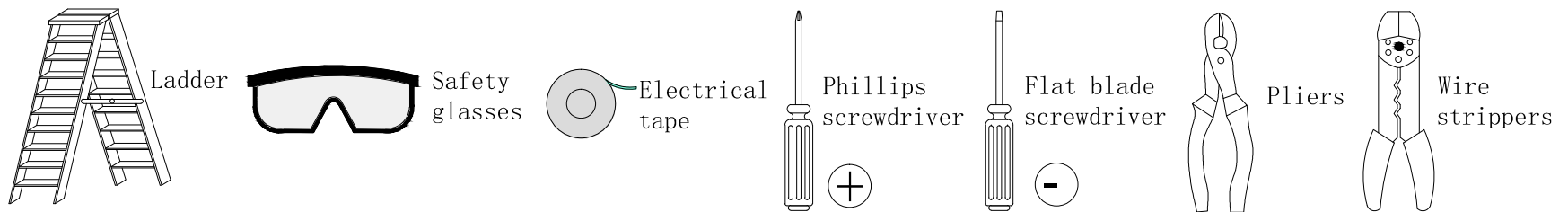

Glass

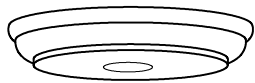

canopy

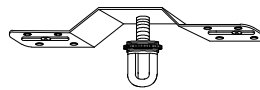

Mounting Unit

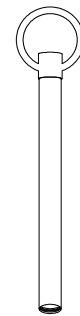

Rods

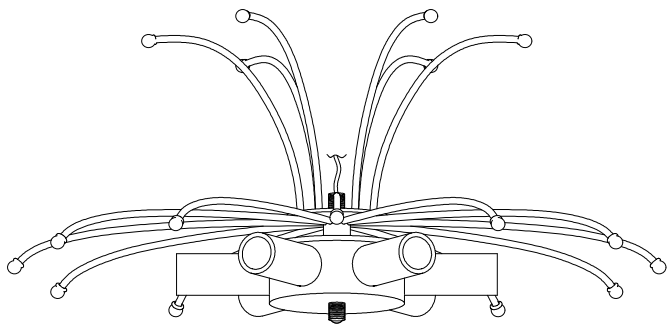

lamp body (A)

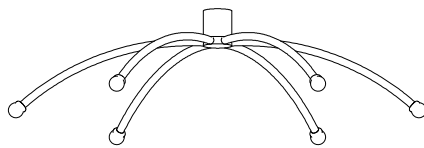

lamp body (B)



lamp body (C)

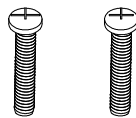

Mounting Screws

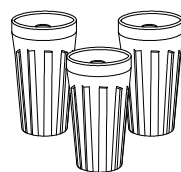

Wire Nuts

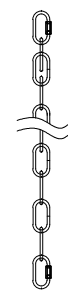

sling chain

*PARTS SHOWN MAY DIFFER SLIGHTLY PER LIGHT FIXTURE

PENDANT LIGHT (ROD)
Assembly Instructions
MODEL#: 8217PL-06GD-US

STEP 1

Thread the lamp body line through the suspension rod, suspension chain, ceiling plate, and hanging plate ring in sequence

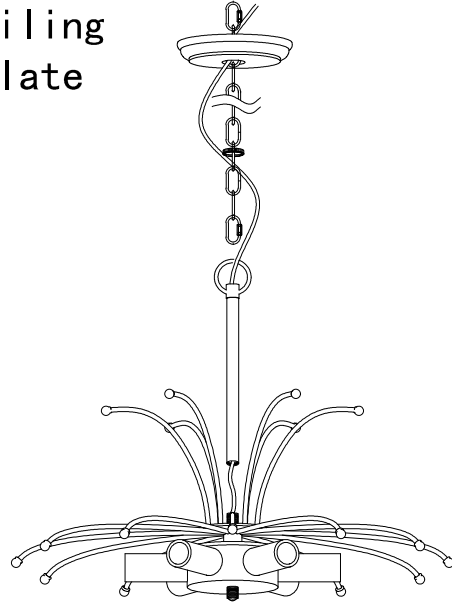

STEP 2

Install the hanging plate on the reserved box;

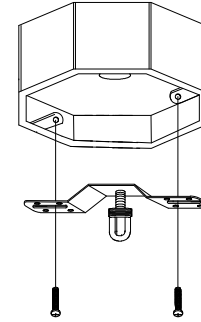

STEP 3

Make the electrical connection from the junction box to the fixture. Connect the ground wire to the mounting unit using the preinstalled green ground screw. Then, connect the positive, negative and ground wires with the supplied wire nuts. Secure with electrical tape

Connect Clear, Brown, Gold or Black Parallel Wire without tracer (round & smooth) or Black Fixture Wire to:

Black or Red Supply Wire or Insulated Wire (other than green) with copper conductor.

Connect Clear, Brown, Gold or Black *Parallel Wire with tracer (square & ridged) or White Fixture Wire to:

White Supply Wire or Insulated Wire (other than green) with silver conductor

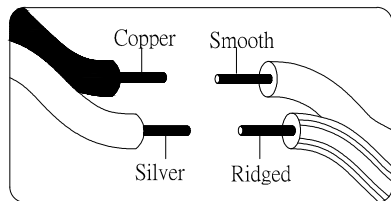
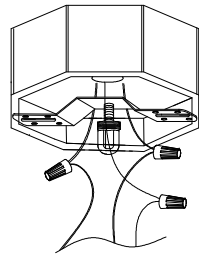

STEP 4

Hang the iron chain onto the hanging plate, then push up the ceiling plate and secure it with the hanging plate ring

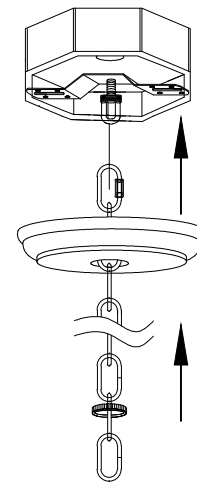

STEP 5

Assemble the lamp body

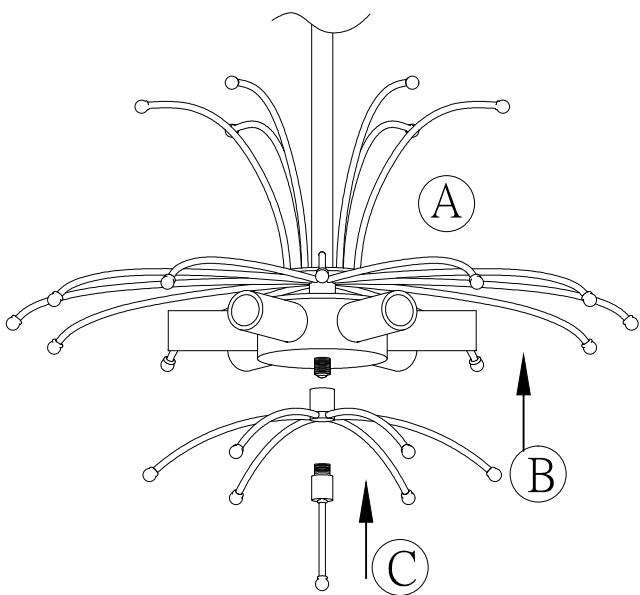

STEP 6

1. Hang the petal glass on the lamp body and fix it with a round piece
 2. Install the bulb (Bulbs NOT Included) E12" B" MAX40W

