

seville classics®

15-Drawer Organizer Cart

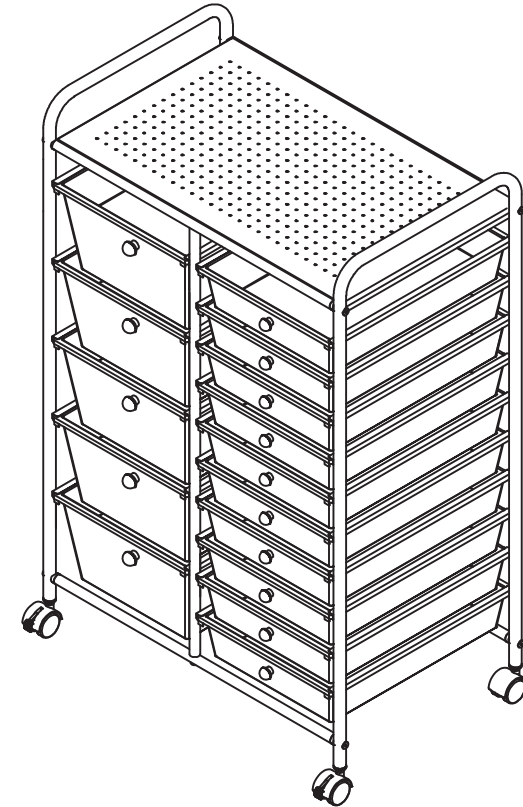

Customer Service Information

Seville Classics Inc.

Telephone: (800) 323-5565

Fax: (310) 533-3899

Hours: 8:30 AM – 4:30 PM (PST)











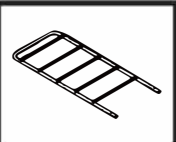

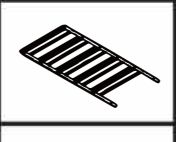

Email: Support@SevilleClassics.com

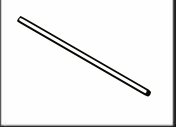
Homepage: www.SevilleClassics.com

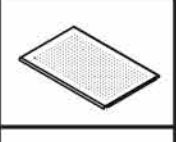
Model #: WEB208, WEB908, SHE16285B

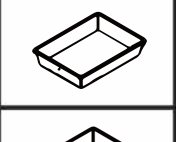
Thank you for choosing Seville Classics! We hope that you enjoy your organizer cart. Please read through this user guide for parts list, assembly instructions, frequently asked questions and contact info.

Parts List

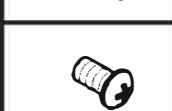
A. Left Frame (1)		H. Pull (15)	
B. Right Frame (1)		I. Sleeves (4)	
C. Middle Frame (1)		J. Washer (8)	
D. Crossbar (4)		K. Hex Key (1)	
E. Shelf (1)		L. Locking Caster (2)	
F. Small Drawer (10)		M. Caster (2)	
G. Large Drawer (5)		N. Hex Screw (12)	
		O. Screw (15)	

FAQs

Q. Can I use it without the top shelf?

A. Yes! Simply pop off the top shelf for easy access to bins.

Q. Can I use it without the casters?

A. No, the cart is not designed to be used without the casters.

Q. Can I take the drawers out?

A. Yes! You can use the drawers in the organizer or separate from the organizer. Each small drawer can hold up to 3.3 lbs each and each large drawer can hold up to 5.5 lbs each.

Specifications

Dimensions: 25.2" W x 15.3" D x 38.2" H

Weight capacity per large drawer: 5.5 lbs. (2.5 kg.)

Weight capacity per small drawer: 3.3 lbs. (1.5 kg.)

Weight capacity on top shelf: 16.5 lbs. (7.5 kg.)

Total Weight Capacity: 77 lbs. (34.9 kg.)

Warranty

Seville Classics product is backed by a limited 1-year manufacturer's warranty unless otherwise specified. The warranty protects against original defects in material or workmanship under normal home or office use for the duration of the warranty period.

Required Tools (not included)

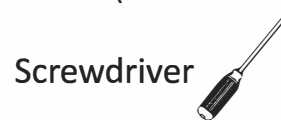

Please make sure you have all the parts on this list.

If you're missing parts, contact us for replacements at
(800) 323-5565 or send an email to Support@SevilleClassics.com

STEP 4.

Attach **DRAWER PULLS (H)** to **DRAWERS (F,G)** using **SCREWS (O)** and screwdriver.

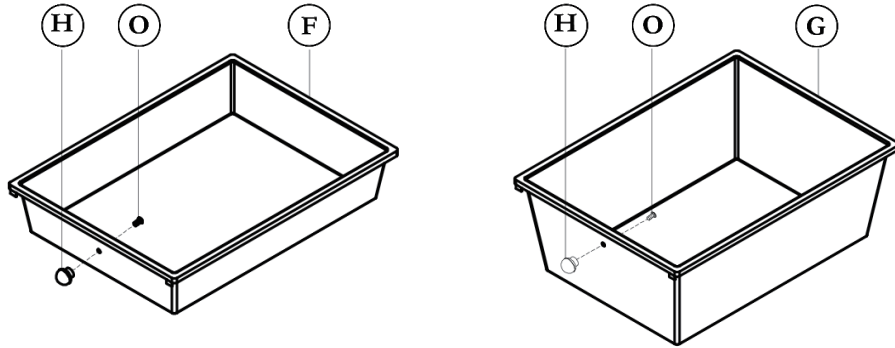

STEP 5.

Clip on **SHELF (E)** to crossbars.

Insert **DRAWERS (F,G)** into guides carefully.

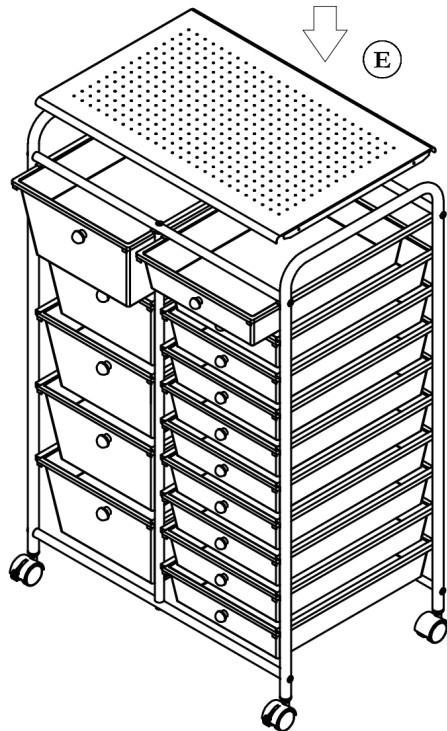

Assembly Instructions

STEP 1. TIP: Assemble on a level surface.

Insert **SLEEVES (I)** into bottoms of **LEFT, RIGHT FRAMES (A,B)**.

Firmly press sleeves into frames until flush with frame bottoms.

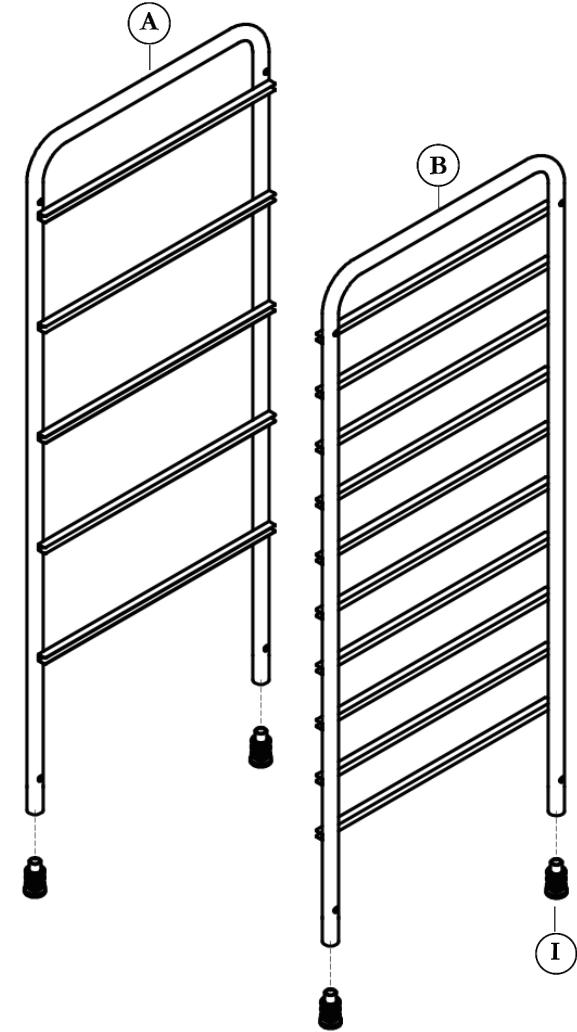

Tighten all screws evenly with **HEX KEY (K)**.

STEP 2.

Insert **HEX SCREW (N)** through center of **CROSSBARS (D)** into top and bottom ends of **MIDDLE FRAME (C)** poles.

Tighten with **HEX KEY (K)**.

Repeat for all **CROSSBARS (D)**.

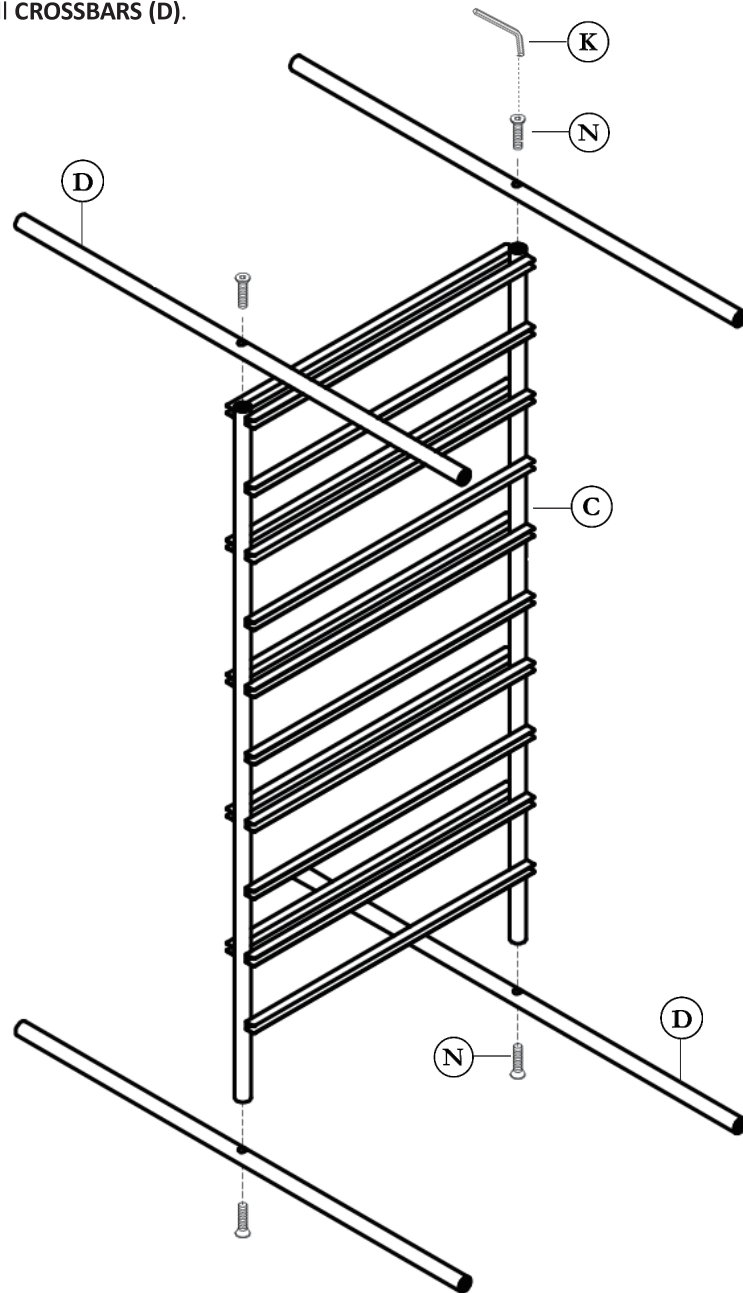

STEP 3.

Attach **LEFT, RIGHT FRAMES (A,B)** to **CROSSBARS (D)** with **HEX SCREWS (N)**.

MAKE SURE to fit **WASHERS (J)** between crossbar ends and frames.

Flat side of washer MUST face end of crossbar.
Curved side of washer MUST fit around frame.

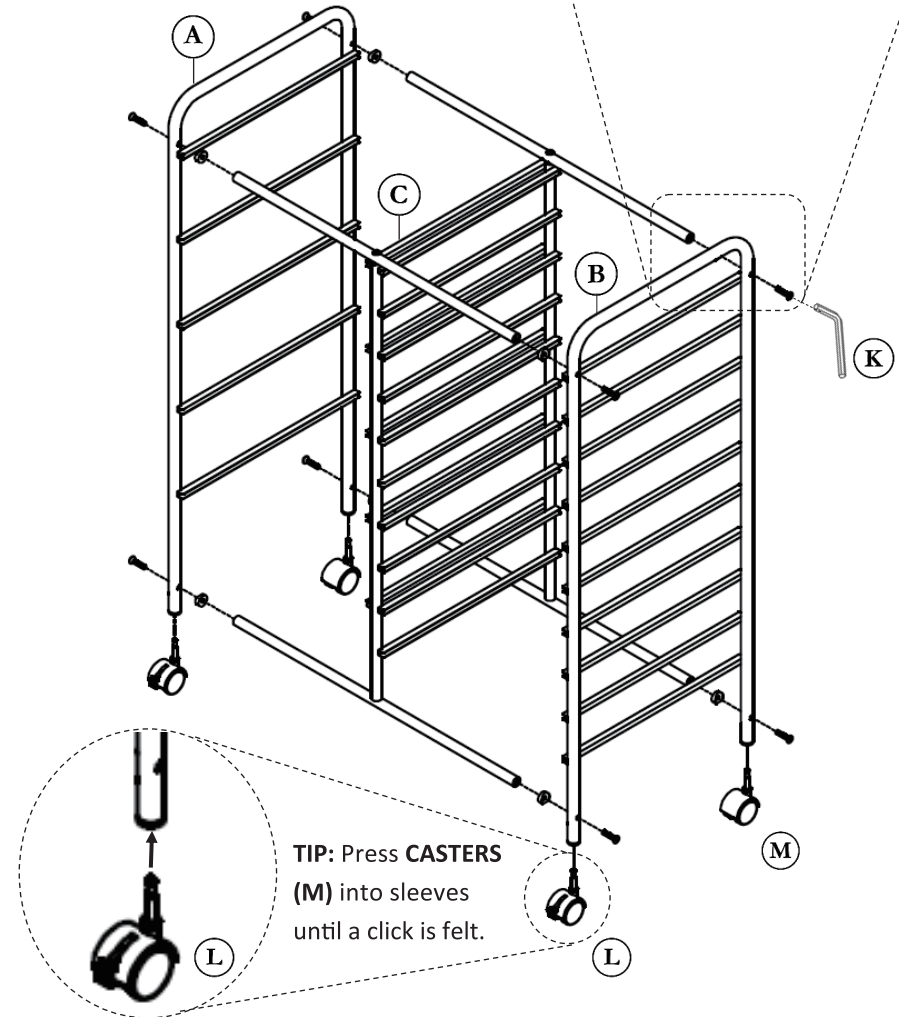
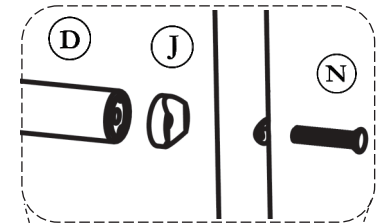

Press **LOCKING CASTERS (L)** and **CASTERS (M)** into the sleeves installed in **STEP 1**.

TIP: Do not tighten screws until the drawers are in place.