

Parts and Damage Replacement Procedure

1. Please inspect your purchase immediately.
2. This procedure covers product purchased from an authorized and was received in its originally sealed carton.
3. If you find a part missing or damaged, you have a 30-day window in which to order a replacement part from the date on your purchase receipt.
4. You have 3 ways to do this. You will need a copy of your purchase receipt.
 - a. By Fax: Fax the parts order form below and along with your receipt
 - b. By Email: Email the order form and along with your receipt
 - c. By Mail: Fill out the parts order form below and along with a copy of your receipt send it to furniture parts department
5. Once this order is sent in, you will be notified if the part(s) you are requesting can or cannot be shipped within 7-10 business days.

**A COPY OF YOUR PURCHASE RECEIPT OR INVOICE MUST BE ATTACHED TO THIS ORDER FORM.
NO ORDERS WILL BE PROCESSED WITHOUT PROOF OF PURCHASE.**

NAME: _____

ADDRESS: _____ (No Post Office Boxes)

CITY: _____ STATE: _____ ZIP: _____

PHONE: _____ FAX: _____

EMAIL: _____

REASON FOR REPLACEMENT/PLEASE CHECK APPROPRIATE BOX.

- Damaged /scratched, cracked, broken, crushed, etc.
- Mechanical malfunction/ drawer glides, swivel mechanisms, lid stays, etc.
- Missing pieces
- Unfinished surface
- Wrong color
- Other

IF MORE THAN ONE MODEL NUMBER IS LISTED ABOVE, PLEASE SPECIFY THE EXACT MODEL NUMBER OF YOUR ITEM IN THE SPACE PROVIDED BELOW.

Model Number	Part Letter Code	Quantity







KING BED

ASSEMBLY INSTRUCTION

KING/CAL. KING HEADBOARD & FOOTBOARD W/ 4 SLATS,
8 SUPPORTS + QUEEN / KING SIDERAIL SET (2)

Thank you for purchasing this quality product. Be sure to check all packing material carefully for small Hardware which may have come loose inside the carton during shipment. Identify and count all Hardware and compare with the Hardware List below.

Component List		
Headboard & Footboard		
No	Descriptions	Qty
A	Headboard Panel	1
B	Footboard Panel	1
C	Bed Slat	4
D	Bed Slat Support	8
E	Leg (L/R)	2

Side Rail		
No	Descriptions	Qty
F	Side Rail (L/R)	2
Hardware List In Headboard & Footboard		
No	Descriptions	Qty
1	JCBC Screw M6 x 30mm 	6
2	Spring Washer Ø1/4" 	6
3	Flat Washer Ø1/4" x 13mm 	6
4	L Key M4 	1
5	L Key M5 	1
6	CSK M4 x 32mm 	8

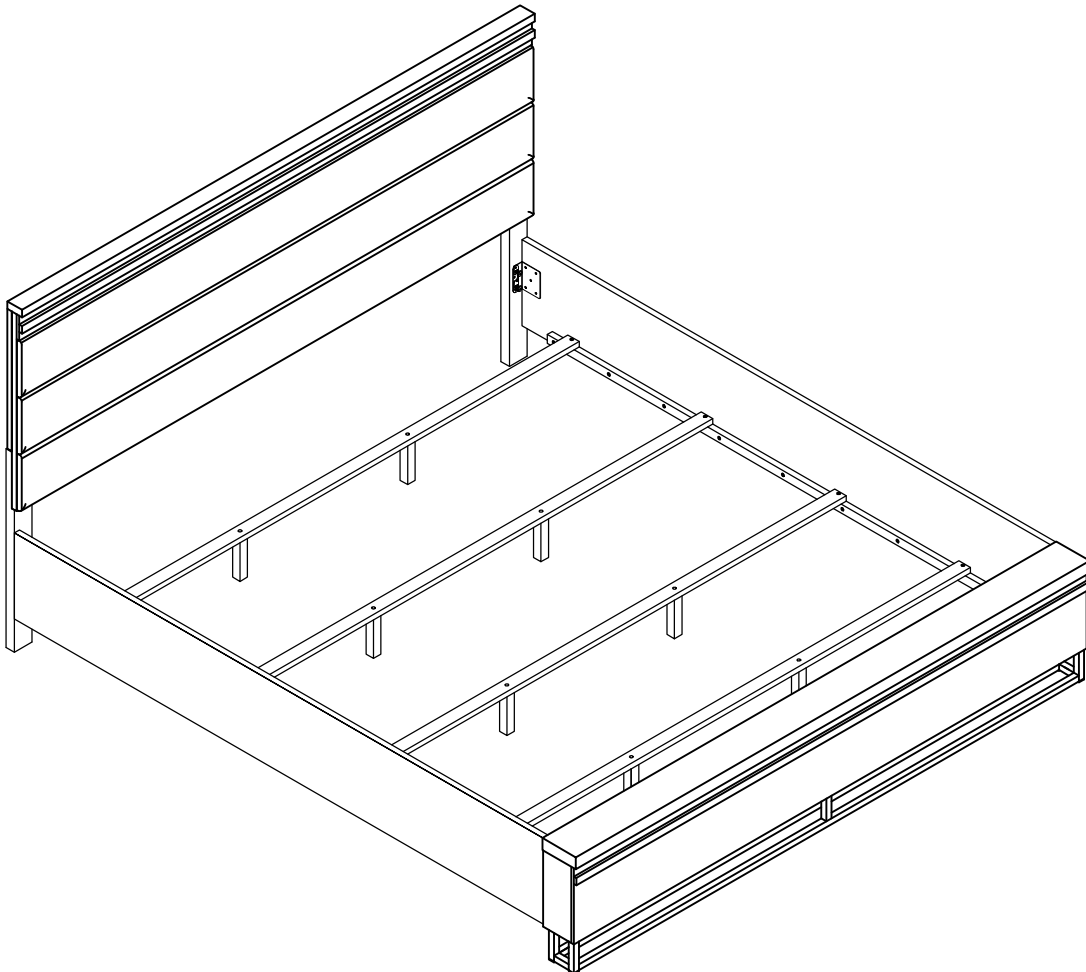

KING BED

ASSEMBLY INSTRUCTION

KING/CAL. KING HEADBOARD & FOOTBOARD W/ 4 SLATS,
8 SUPPORTS + QUEEN / KING SIDERAIL SET (2)

Thank you for purchasing this quality product. Be sure to check all packing material carefully for small Hardware which may have come loose inside the carton during shipment. Identify and count all Hardware and compare with the Hardware List below.

STEP 1 : Attach & tighten the Headboard Leg (E) to the Headboard Panel (A). Affix Headboard & Headboard Leg using JCBC screw M6 x 30mm (1), Spring Washer (2), Flat Washer (3) using L Key M4 (4).

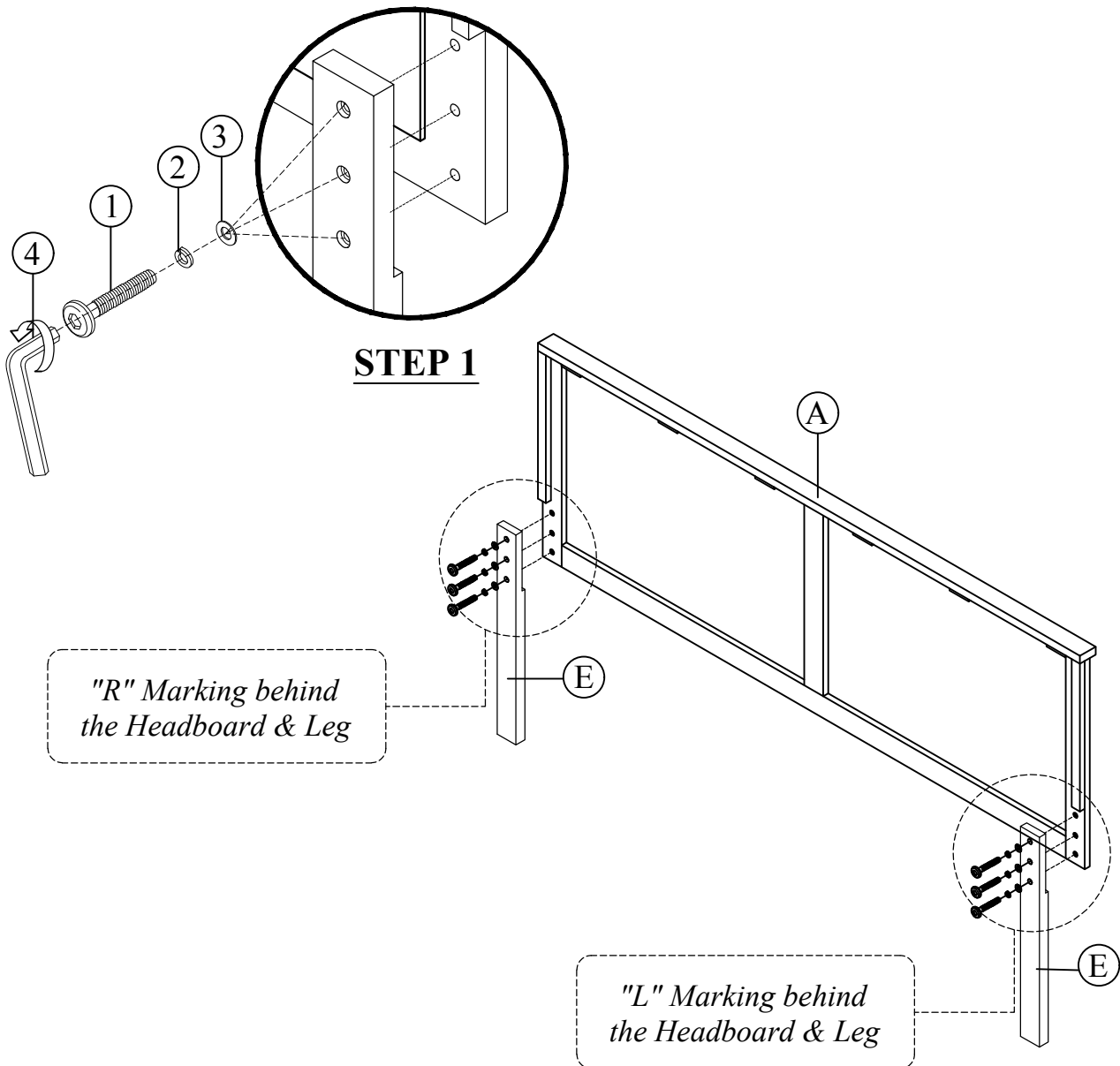

KING BED

ASSEMBLY INSTRUCTION

KING/CAL. KING HEADBOARD & FOOTBOARD W/ 4 SLATS,
8 SUPPORTS + QUEEN / KING SIDERAIL SET (2)

Thank you for purchasing this quality product. Be sure to check all packing material carefully for small Hardware which may have come loose inside the carton during shipment. Identify and count all Hardware and compare with the Hardware List below.

STEP 2 : Attach the Side Rail (F) to Headboard Leg R/L (E). Tighten screw on Headboard Leg by using L Key M5 (5) & repeat the same step on Footboard (B).

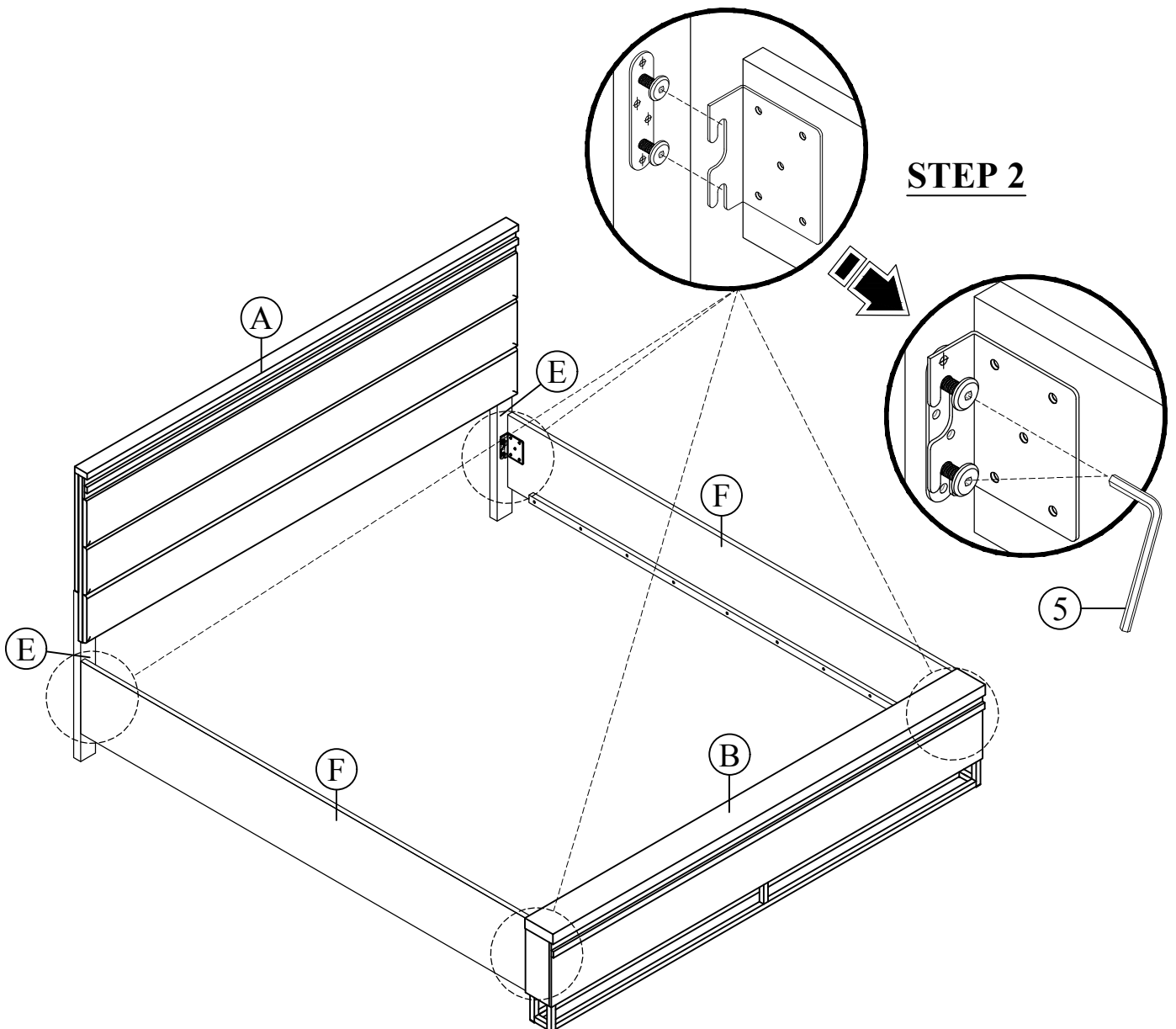

KING BED

ASSEMBLY INSTRUCTION

KING/CAL. KING HEADBOARD & FOOTBOARD W/ 4 SLATS,
8 SUPPORTS + QUEEN / KING SIDERAIL SET (2)

Thank you for purchasing this quality product. Be sure to check all packing material carefully for small Hardware which may have come loose inside the carton during shipment. Identify and count all Hardware and compare with the Hardware List below.

STEP 3 : Attach the Bed Slat Support (D) to the bottom of each Bed Slat (C).

STEP 4 : Attach Bed Slat (C) and tighten to Side Rail (F) with CSK M4 x 32mm (6).

