

# ASSEMBLY INSTRUCTIONS

## PARTS AND FITTING PACKAGING DETAIL

### BOX #1

A. TOP

1 PC

B. LEGS

4 PCS

C. SHELF

1 PC

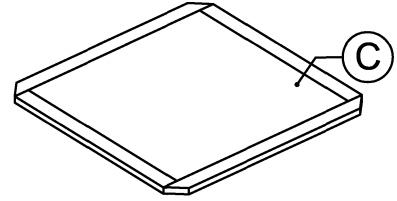
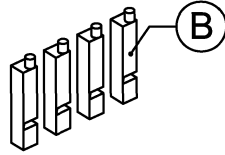
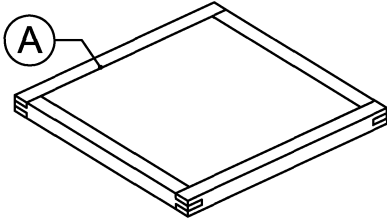

## SQUARE COFFEE TABLE ASSEMBLED

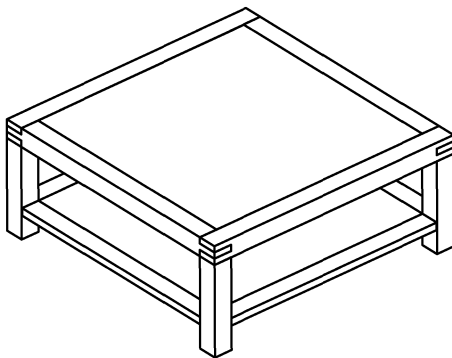

## HARDWARE\* PACKED IN BOX #1

H1	BOLT Ø8 X Ø85mm	4 PCS	H2	LOCK WASHERS 1 X Ø9 X Ø13mm	4 PCS
H3	FLAT WASHERS 1 X Ø8 X Ø20mm	4 PCS	H4	ALLEN KEY Ø 4	1 PC
H5	WOOD SCREW Ø4 X Ø50mm	4 PCS			

YOUR BOX MAY CONTAIN EXTRA HARDWARE

### STEP 1

Attach Legs (B) to upside down Shelf (C), as shown in illustration, using Screws (H5). Screw Driver not provided.

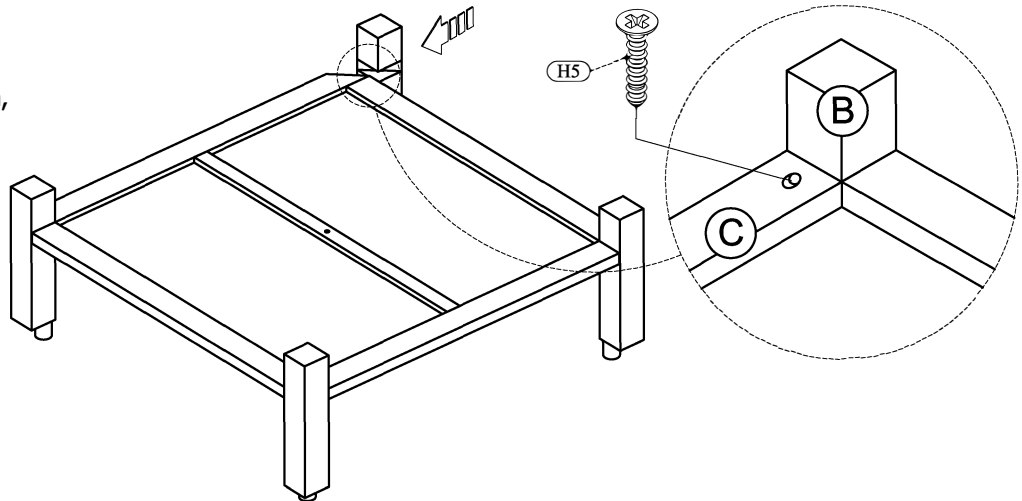

### STEP 2

Attach Leg/Shelf Assembly to upside down Top (A) using Bolts (H1), Lock Washers (H2) and Washers (H3). Tighten completely using Allen Key (H4).

