

---

**SIDE TABLE**  
**PETITE TABLE**  
**MESITA AUXILIAR**

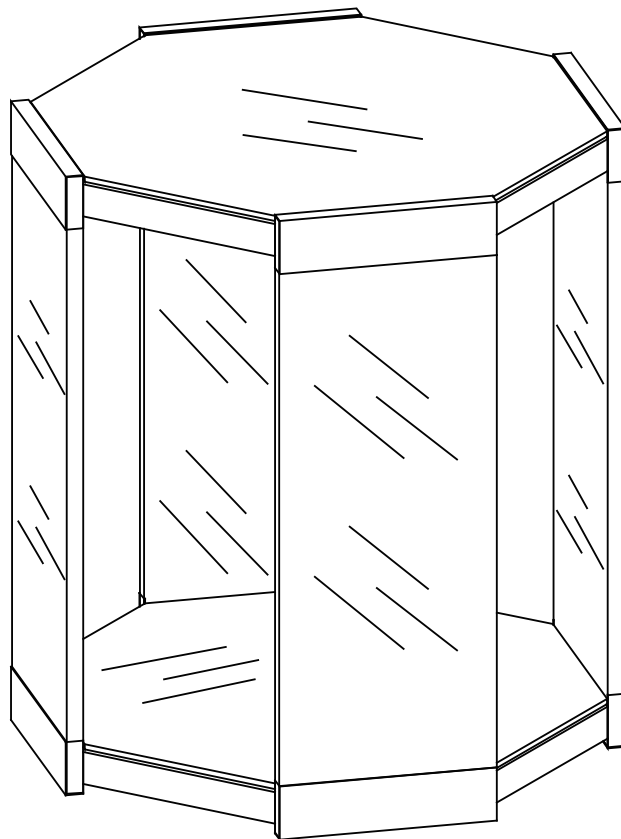

---

## **We are here to help!**

### **Before you return it - contact us.**

We do our best to insure that your furniture arrives in excellent condition. In the event that a part is damaged or missing, we will be happy to provide you with replacement parts, at no charge. In order to receive spare parts, at no charge.

If you need assistance with assembly or replacement parts, please call Customer Service, prior to returning the item to the store.

## **Nous sommes là pour vous aider!**

### **Avant de retourner le produit, veuillez communiquer avec nous.**

Nous faisons tout en notre pouvoir pour que vous receviez votre meuble en parfait état. Toutefois, si une pièce est endommagée ou manquante, nous se fera un plaisir de vous envoyer gratuitement la pièce de rechange. Afin de recevoir gratuitement la pièce de rechange.

Si vous avez besoin d'une pièce de rechange ou d'aide pour l'assemblage, veuillez communiquer avec le Service à la clientèle avant de retourner le produit au magasin.

## **¡Estamos aquí para ayudarle!**

### **Antes de regresar el producto, comuníquese con nosotros.**

Hacemos todo lo posible para que su mobiliario se le entregue en excelentes condiciones. En caso de que falte una pieza o esté dañada. Para recibir piezas de repuesto, sin costo adicional.



Si necesita ayuda para ensamblar su producto o para obtener piezas de repuesto, llame al Servicio al Cliente antes de devolver el artículo a la tienda.

## PART LIST

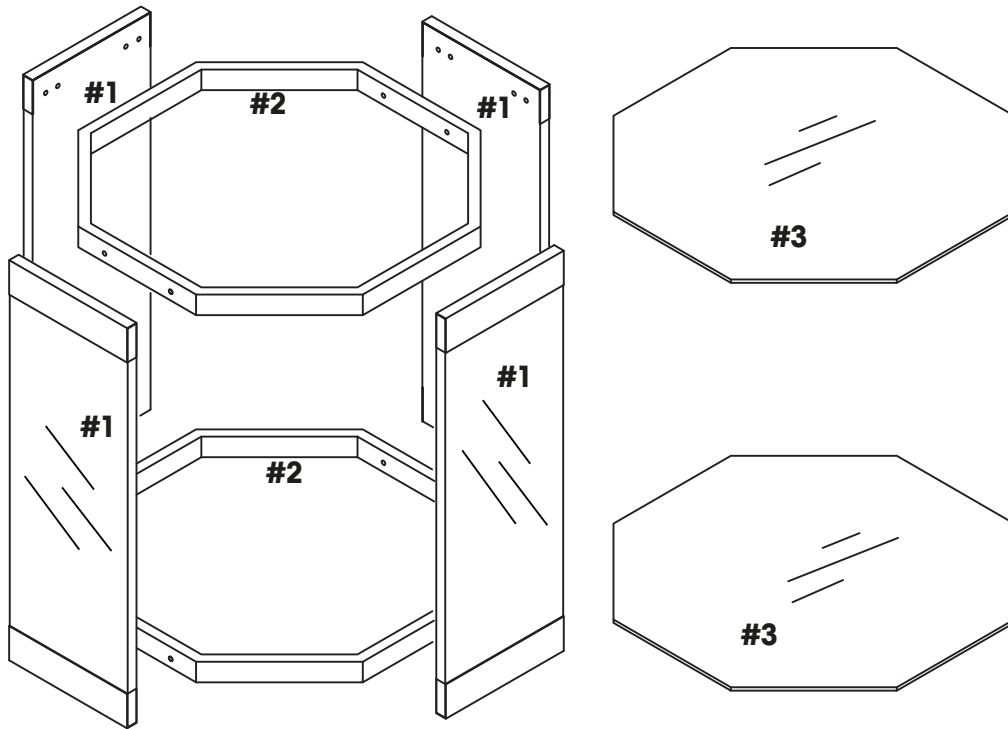
<b>#1</b>	<b>LEG</b>	<b>04</b>
<b>#2</b>	<b>FRAME</b>	<b>02</b>
<b>#3</b>	<b>GLASS</b>	<b>02</b>

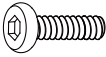

## HARDWARE LIST

<b>A</b>	<b>BOLT (Ø1/4"X1-1/8")</b>		<b>16</b>
<b>B</b>	<b>FLAT WASHER</b>		<b>16</b>
<b>C</b>	<b>FOAM PAD</b>		<b>16</b>

## TOOLS REQUIRED

<b>ALLEN KEY</b>		<b>SUPPLIED</b>
------------------	--	-----------------

### IMPORTANT:

1. Do not tighten bolts completely until all bolts are completely lined up and inserted into holes / nuts.
2. Do not over tighten screws and bolts to avoid stripping.
3. Please use hand tools to assemble this product. Do not use power tools.

1.

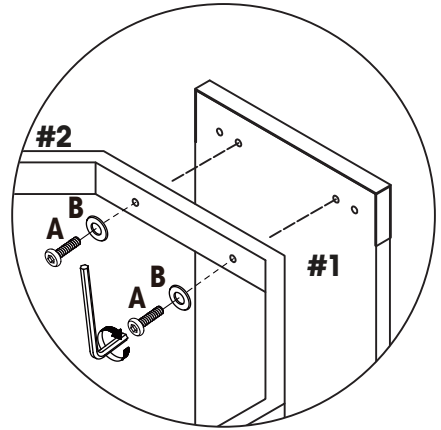
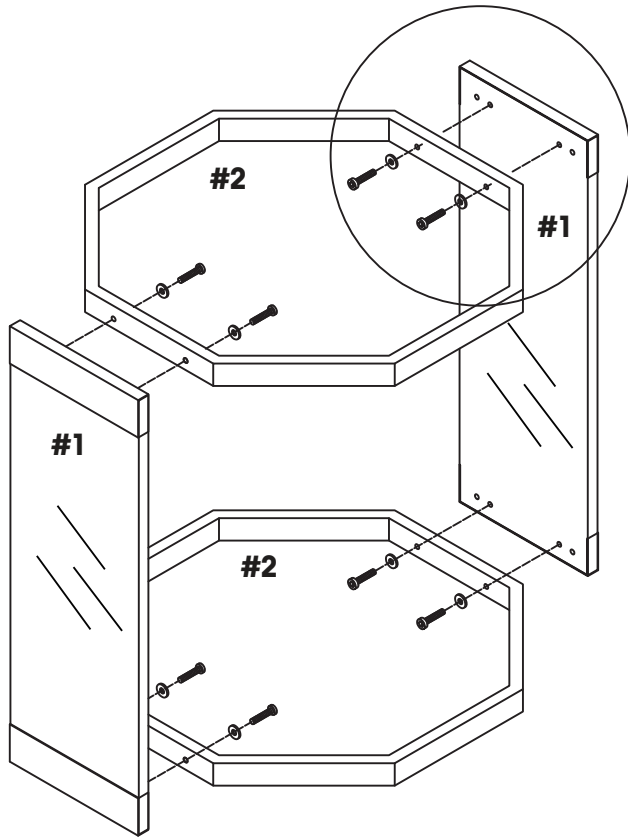

A		08
B		08

2.

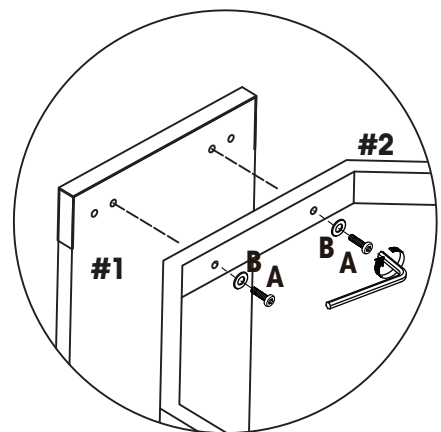
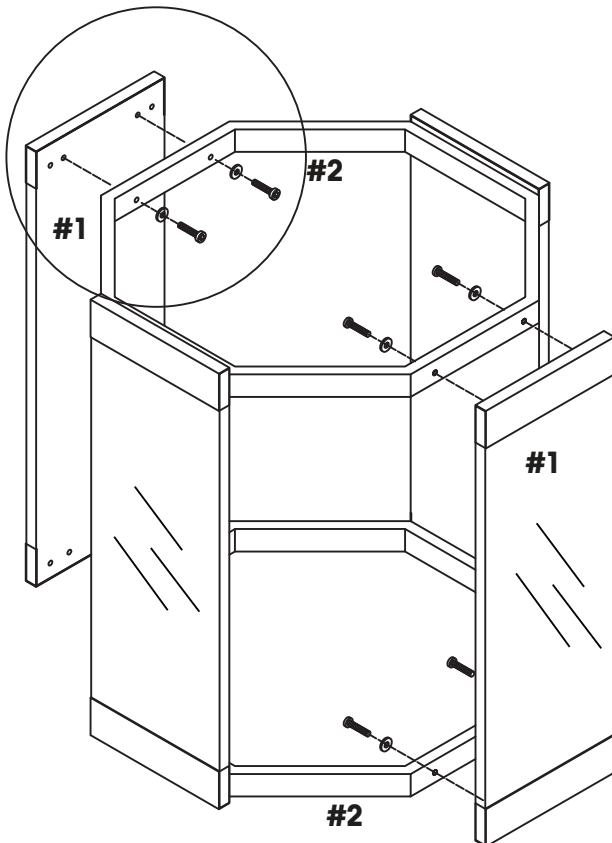

A		08
B		08

3.

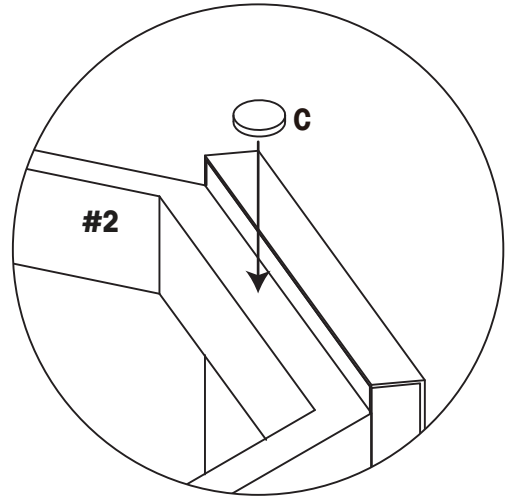
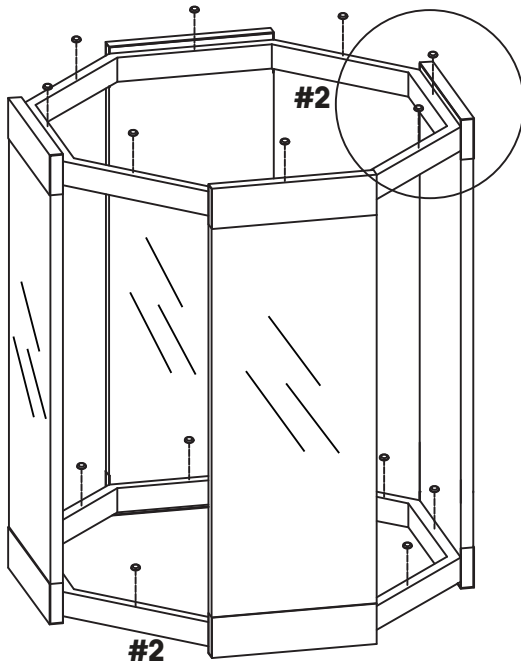

C		16
---	---	----

4.

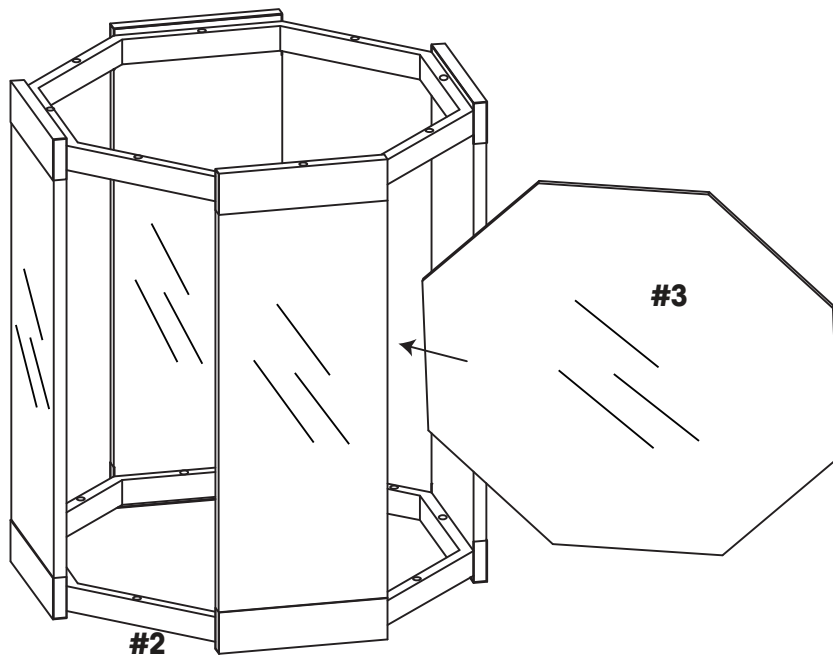

5.

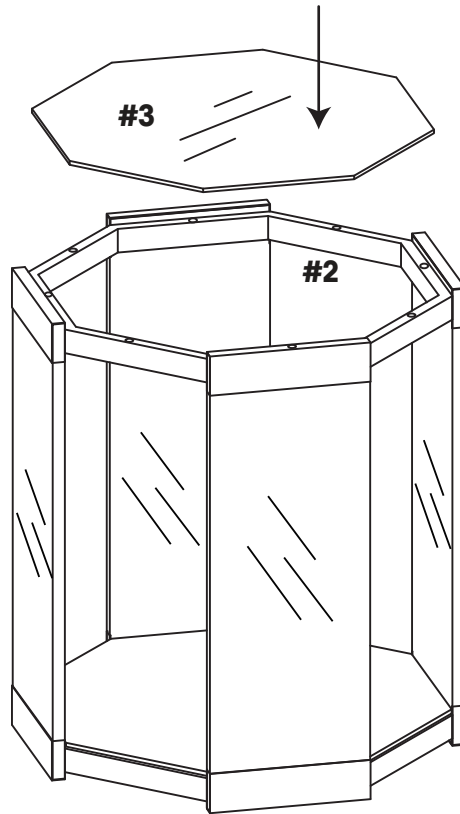

6.

