

STANDING DESK

ES-RF9 48"-63"

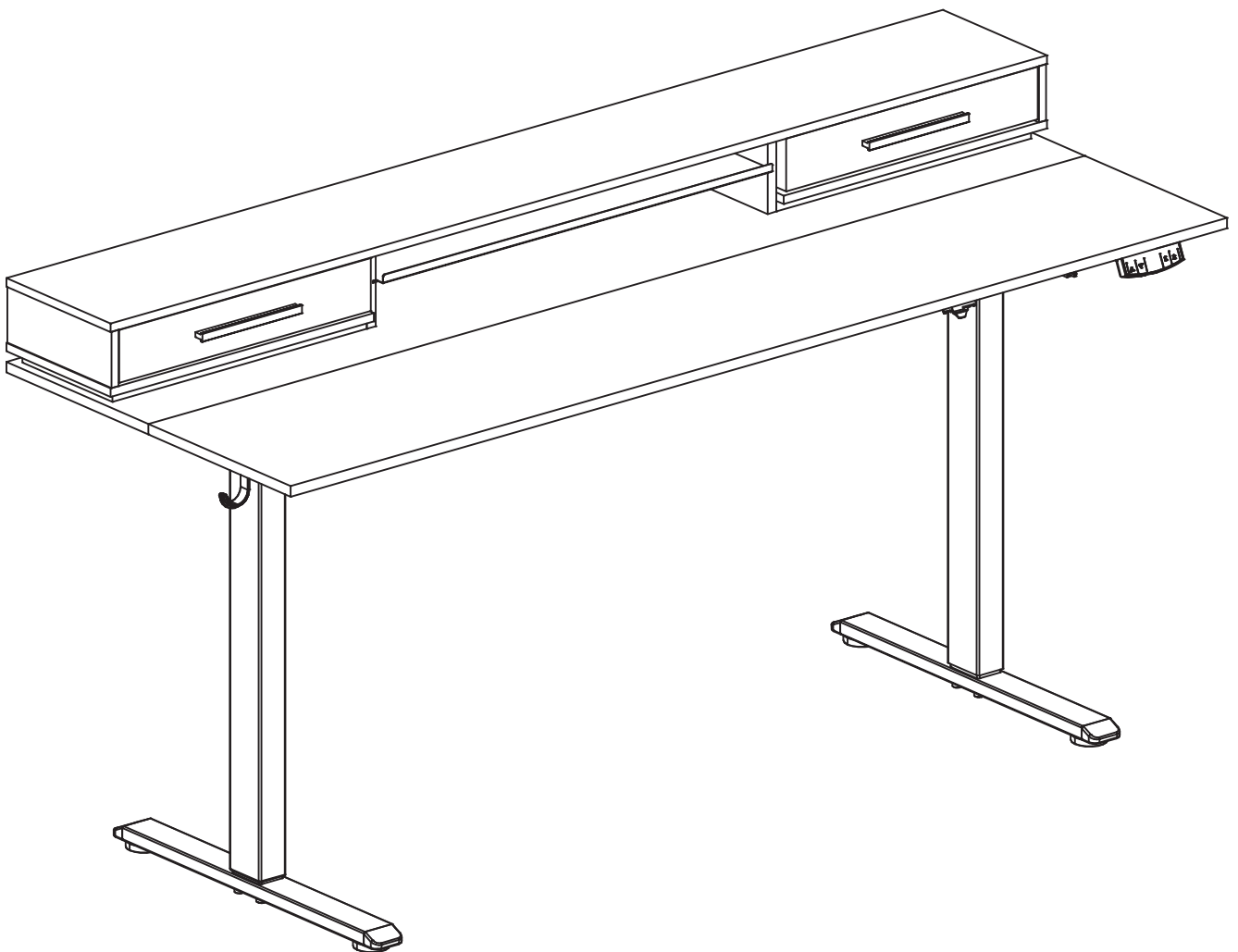

German(DE)

Warnung:

- Halten Sie Kinder und Tiere während des
- Gebrauchs vom Schreibtisch fern und stellen Sie sicher, dass der Schreibtisch keine Wände berührt. Bitte entfernen Sie Hindernisse 20 cm über dem Schreibtisch und 51 cm unter dem Schreibtisch während des Betriebs.
- Betreiben Sie diesen höhenverstellbaren
- Schreibtisch nur in einer Umgebungstemperatur von 0°C bis 40°C.
- r sicheren Position. Bitte lesen Sie diese Anweisungen sorgfältig durch, bevor Sie einen höhenverstellbaren Schreibtisch verwenden.
- Die Firma lehnt jegliche Garantie oder Haftung für Schäden oder persönliche Verletzungen ab, die durch abnormales oder außerhalb der Gerätebetriebsvorschriften entstehen.
- Personen ist es untersagt, sich auf den Tisch zu lehnen, um das Risiko des Umkippens zu vermeiden.
- Verwenden Sie keine scharfen Gegenstände, um die Tischplatte zu durchbohren oder zu
- zertrümmern.

French(FR)

Avertissement:

- Eloignez les enfants et les animaux du bureau pendant son utilisation et assurez-vous que le bureau ne touche aucun mur.
- Veuillez retirer les obstacles situés à 20 cm au-dessus du bureau et à 51 cm en dessous du bureau pendant le fonctionnement.
- Utilisez ce bureau réglable uniquement dans une température ambiante de 0°C à 40°C.
- Éloignez les produits des gaz corrosifs, des liquides et des objets poussiéreux.
- Gardez vos mains, vos pieds et autres parties du corps dans une position sûre pendant le fonctionnement.
- Veuillez lire attentivement ces instructions avant
- d'utiliser un bureau à hauteur réglable.
- La société décline toute garantie ou responsabilité pour tout dommage ou blessure personnelle résultant d'un fonctionnement anormal ou en dehors des réglementations d'utilisation de l'équipement.
- Il est interdit aux personnes de s'appuyer sur la table pour éviter les risques de basculement. N'utilisez pas d'objets tranchants pour percer ou
- briser les bureaux.

Spanish(ES)

Advertencia:

- Mantenga a los niños y a los animales alejados del escritorio durante su uso y asegúrese de que el escritorio no toque ninguna pared.
- Por favor, retire los obstáculos a 20 cm por encima del escritorio y a 51 cm por debajo del escritorio durante el funcionamiento.
- Utilice este escritorio ajustable solo en un entorno operativo con una temperatura de 0°C a 40°C. Mantenga los productos alejados de gases corrosivos, líquidos y objetos polvorientos. Mantenga las manos, los pies y otras partes del cuerpo en una posición segura durante el funcionamiento.
- Por favor, lea cuidadosamente estas instrucciones antes de utilizar un escritorio de altura ajustable. La empresa declina cualquier garantía o responsabilidad por cualquier dano o lesión
- personal resultante de un funcionamiento anormal o de regulaciones de funcionamiento fuera de equipo.
- Se prohíbe que las personas se apoyen en la mesa para evitar riesgos de vuelco. No utilice objetos afilados para perforar o romper
- los escritorios..

Italian(IT)

Avvertimento:

- Tenere i bambini e gli animali lontani dalla
- scrivania durante l'uso e assicurarsi che la scrivania non tocchi nessun muro.
- Si prega di rimuovere gli ostacoli a 20 cm sopra la scrivania e a 51 cm sotto la scrivania durante il funzionamento.
- Utilizzare questa scrivania regolabile solo in un ambiente operativo con temperatura compresa tra 0°C e 40°C.
- Tenere i prodotti lontani da gas corrosivi, liquidi e oggetti polverosi. Tenere le mani, i piedi e altre parti del corpo in una posizione sicura durante il funzionamento.
- Si prega di leggere attentamente queste istruzioni prima di utilizzare una scrivania regolabile in altezza. La società declina qualsiasi garanzia o responsabilità per eventuali danni o lesioni
- personali derivanti da un funzionamento anormale o da regolamenti di utilizzo dell'attrezzatura al di fuori della norma.
- È vietato alle persone appoggiarsi sul tavolo per evitare rischi di ribaltamento.
- Non utilizzare oggetti appuntiti per forare o
- sfondare le scrivanie.

English(EN)

Alert:

- Keep children and animals away from the desktop during use and ensure that the desktop does not touch any walls.
- Please remove obstacles 20CM above the desktop and 51CM below the desktop during operation.
- Only operate this adjustable desk in the temperature of 32°F-104°F/0°C-40°C operating environment.
- Keep products away from corrosive gases,liquids,and dusty objects.
- Keep your hands,feet,and other body parts in a safe position while operating.
- Please read these instructions carefully before using an adjustable-height desk.
- The Company disclaims any warranty or liability for any damage or personal injury resulting from abnormal or outside-of-equipment operation regulations.
- People are prohibited from leaning on the table to avoid tipping risks.
- Do not use sharp objects to poke/smash desktops.

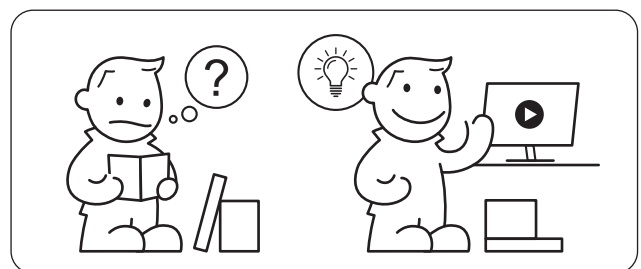
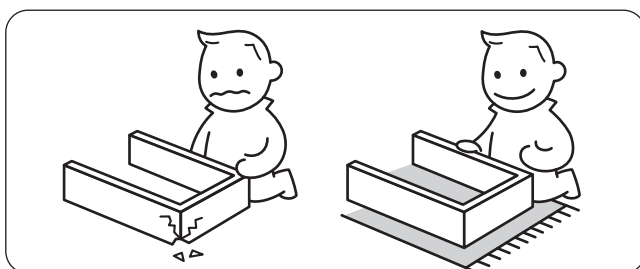
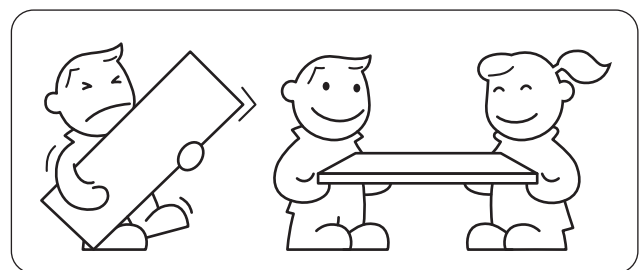
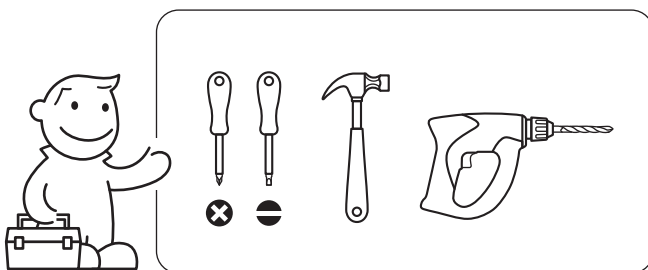
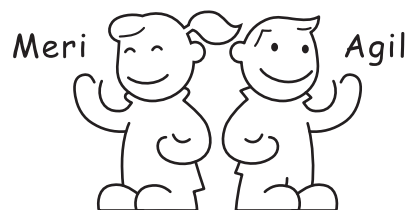

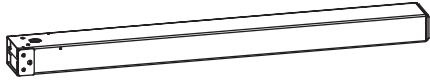

1 X1



2 X1



3 X1

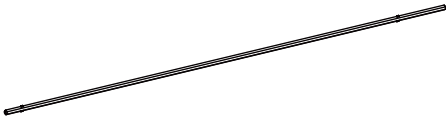

4 X1

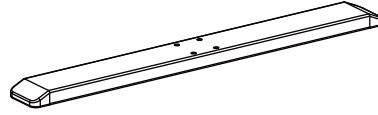

5 X2

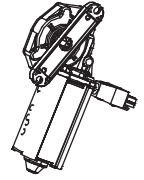

6 X1



7 X2



8 X1

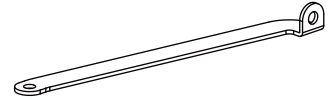

9 X1

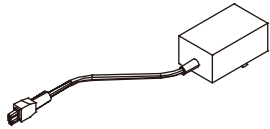

10 X1

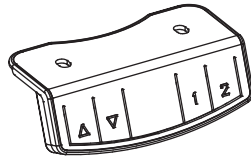

11 X1

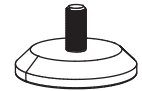

12 X4

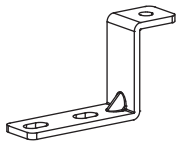

13 X1 (48" / 1.2m)
X2 (55" / 63" / 1.4m / 1.6m)

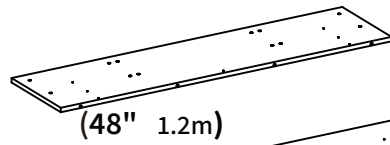

(48" / 1.2m)

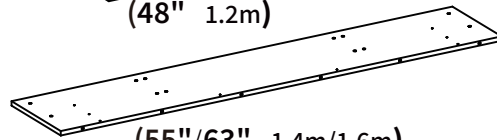

(55" / 63" / 1.4m / 1.6m)

14 X1

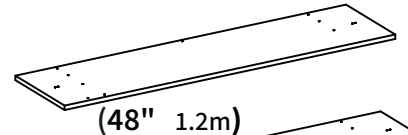

(48" / 1.2m)

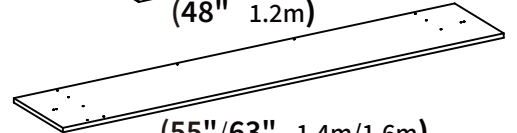

(55" / 63" / 1.4m / 1.6m)

15 X1



16 X1



17 X1

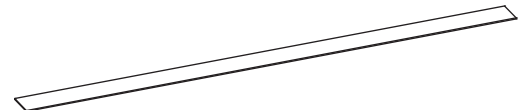

18 X1

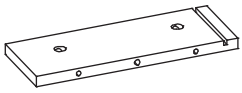

19 X1

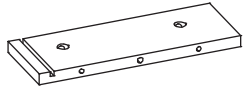

20 X1

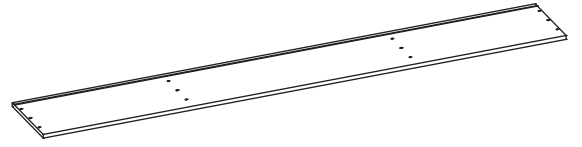

21 X1

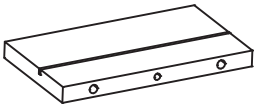

22 X2

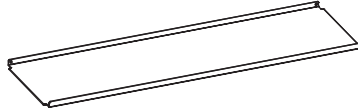

23 X1

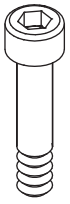

M6X32

A X8

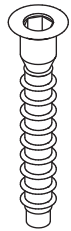

M6.3X50

B X8

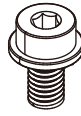

M6X8

C X4

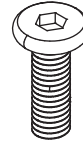

M6X25

D X8

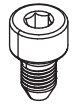

M6X8

E X9 (48"
1.2m)

X10 (55"/63"
1.4m/1.6m)

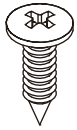

ST4.8X13

F X20 (48"
1.2m)

X22 (55"/63"
1.4m/1.6m)

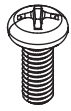

M4X10

G X2



M4X6

H X4



ST6X40

J X8

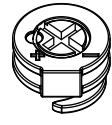

φ 12

K X8



φ8X40

L X4 (48"
1.2m)

X6 (55"/63"
1.4m/1.6m)



φ6X40

M X8



N X3

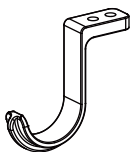

P X2

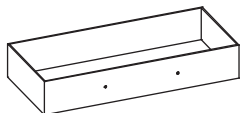

Q X2



R X2



S X1

1

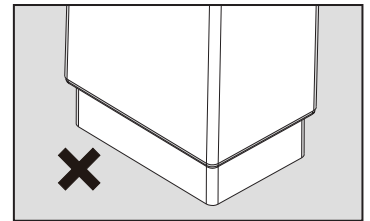
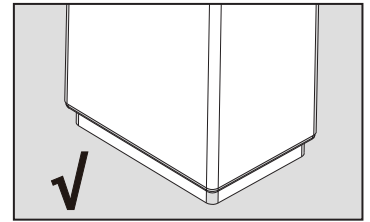
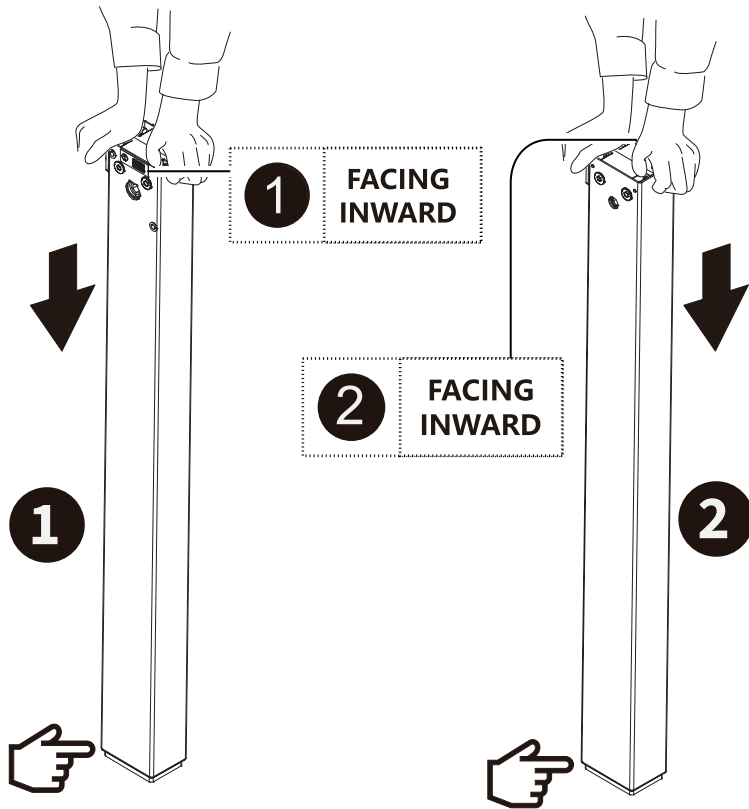

Attention: Check if the height of the two desk legs is consistent. If there is a significant difference, press down to ensure the heights of the two legs are the same.

2

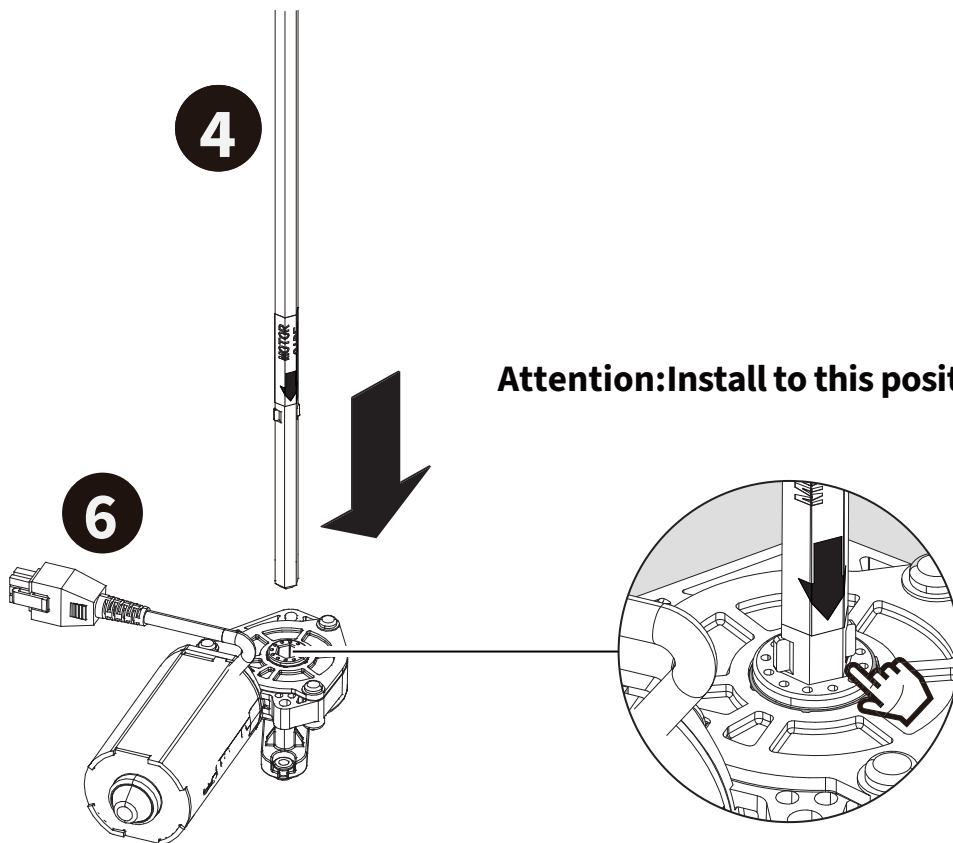

3

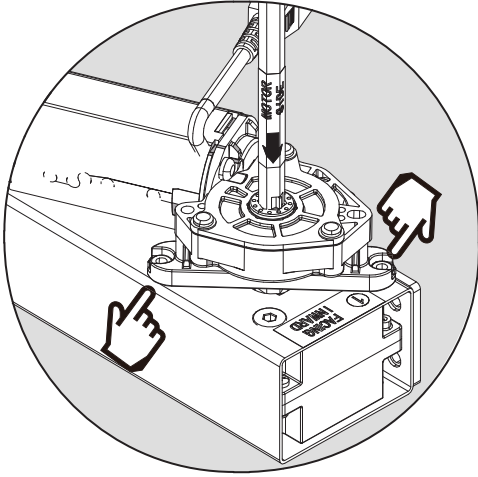

! Attention: The motor mounting hole is located on this side.

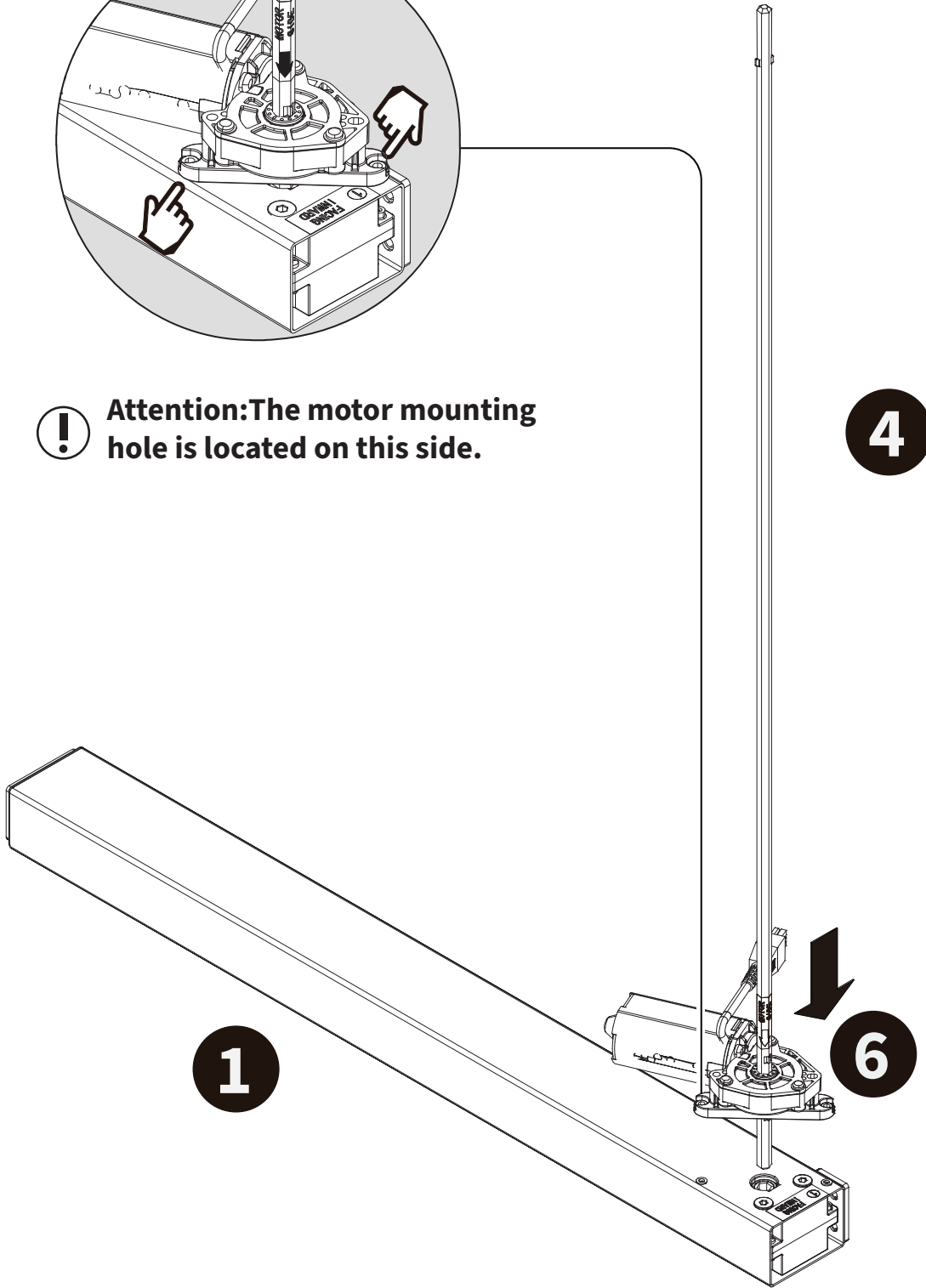

4

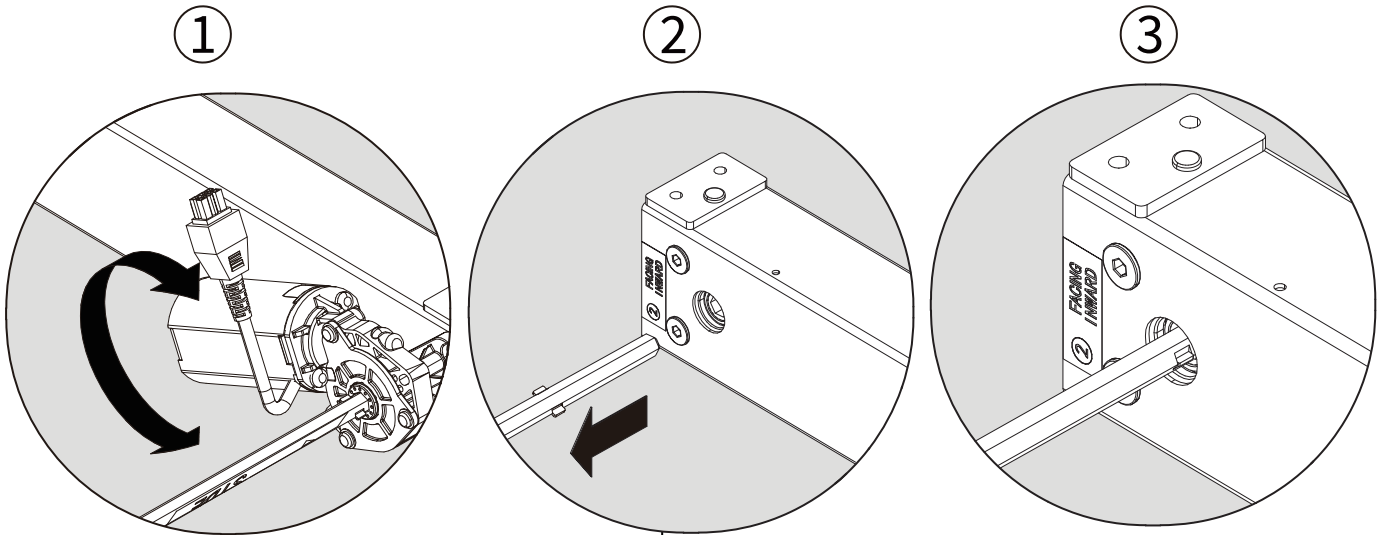

Rotating the motor to make sure the hexagonal metal rod fits into the hole of the table leg labeled 2.

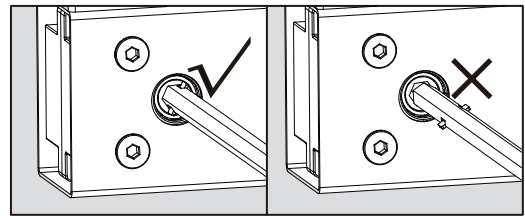

Attention: The column pads face up, and the leg pads labeled 1 face the same direction.

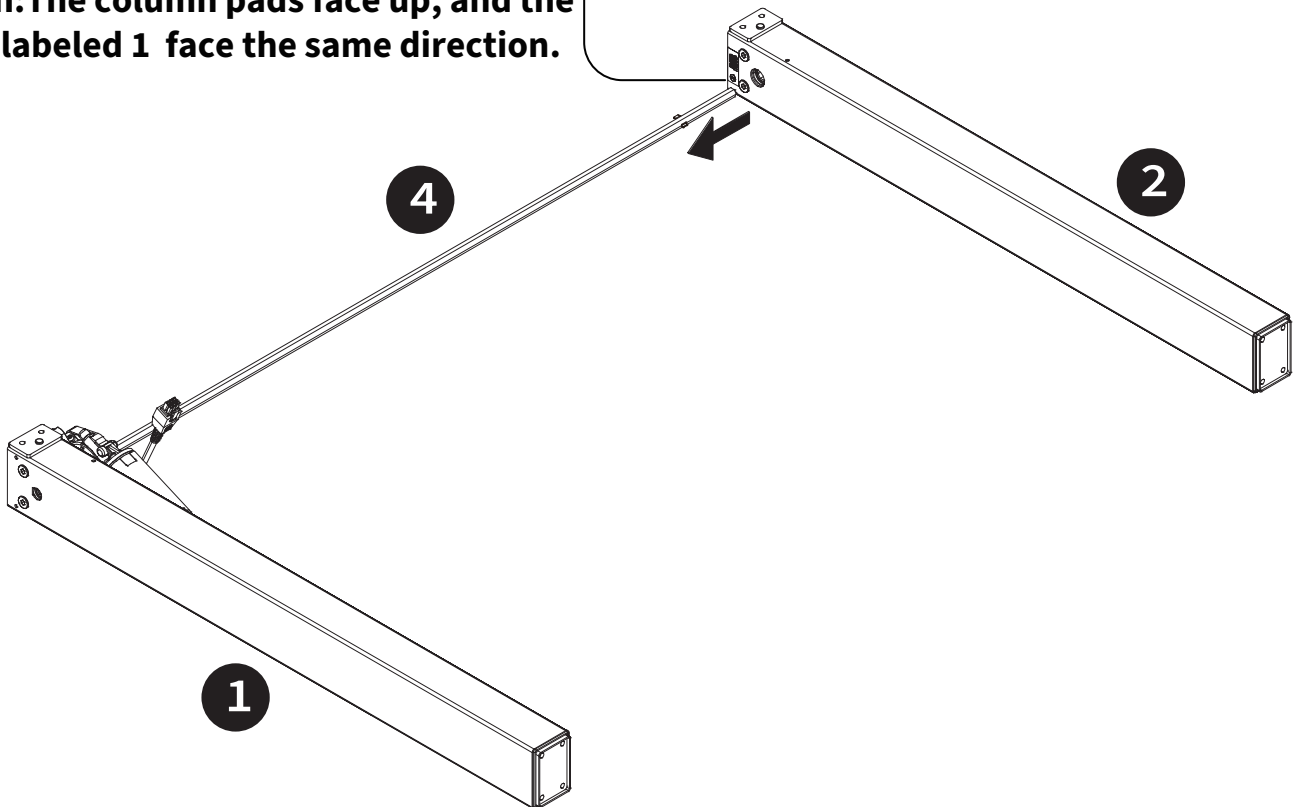

5

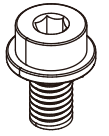
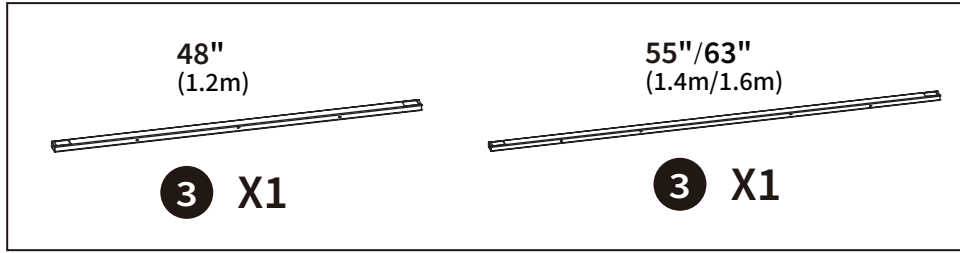

M6X8

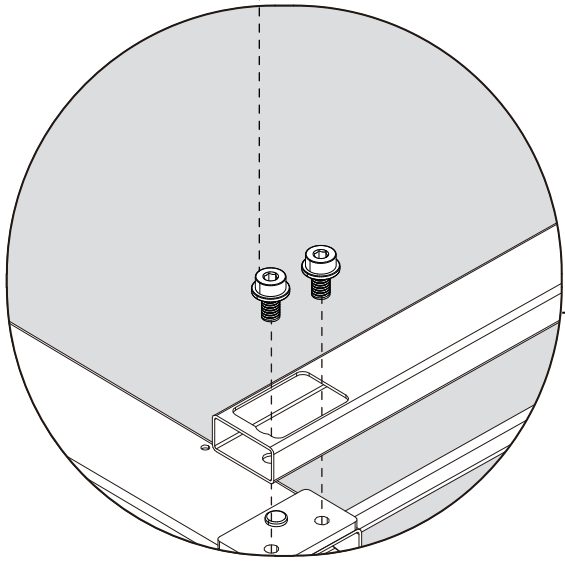
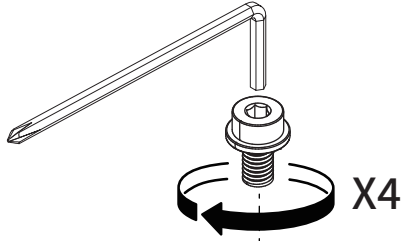

! Prefasten all screws and then tighten all screws.

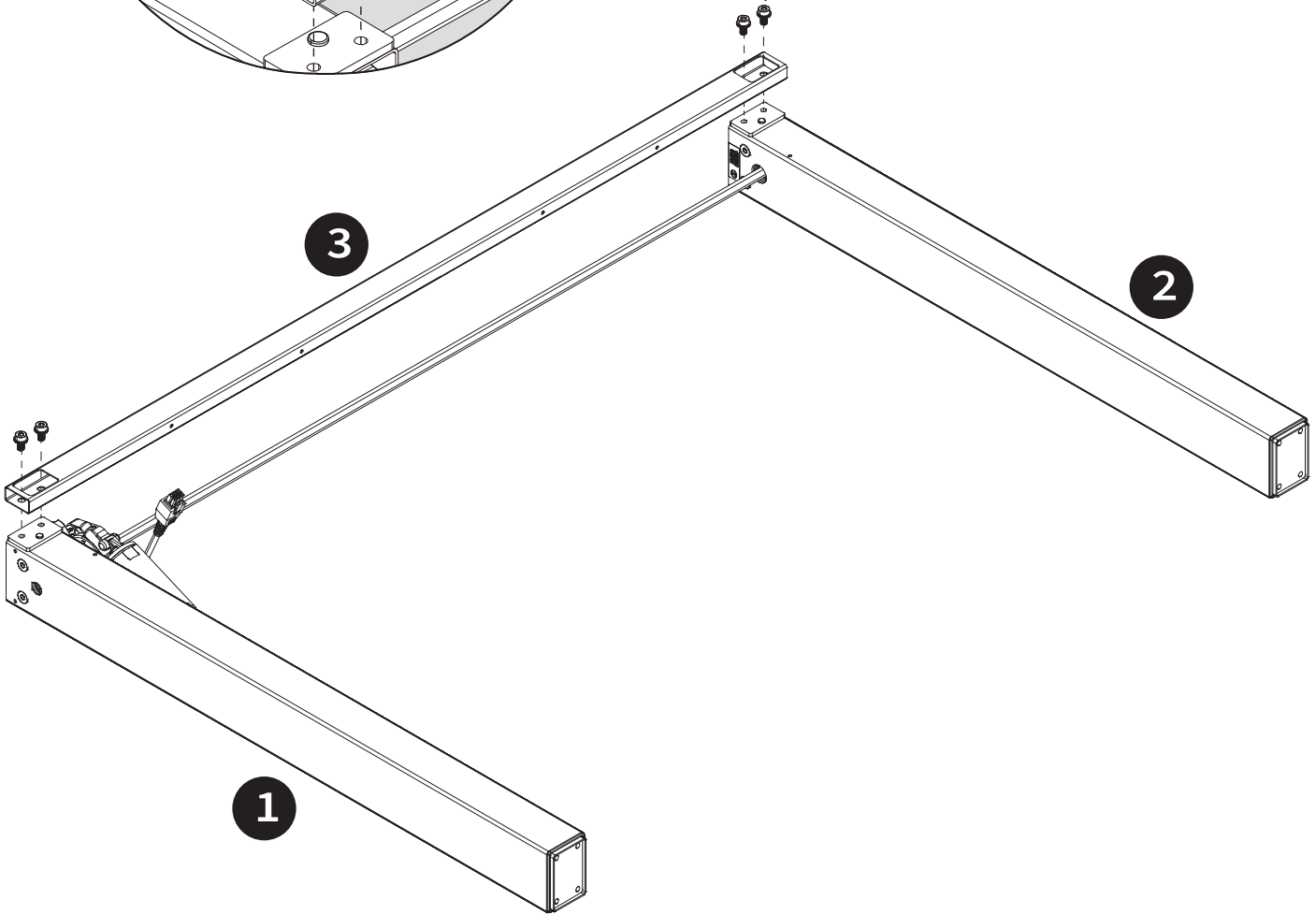

6

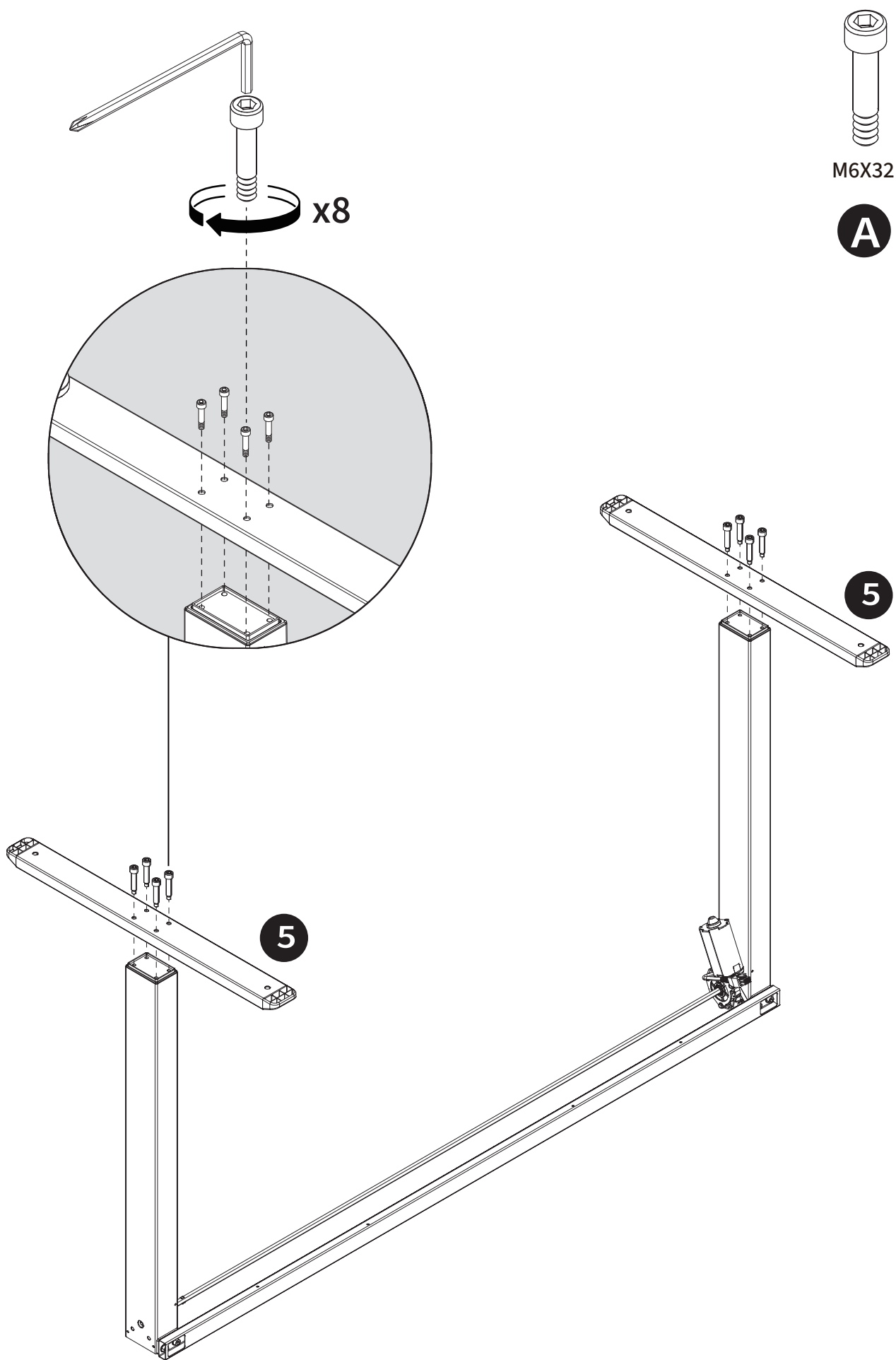

M6X32

A

5

5

7

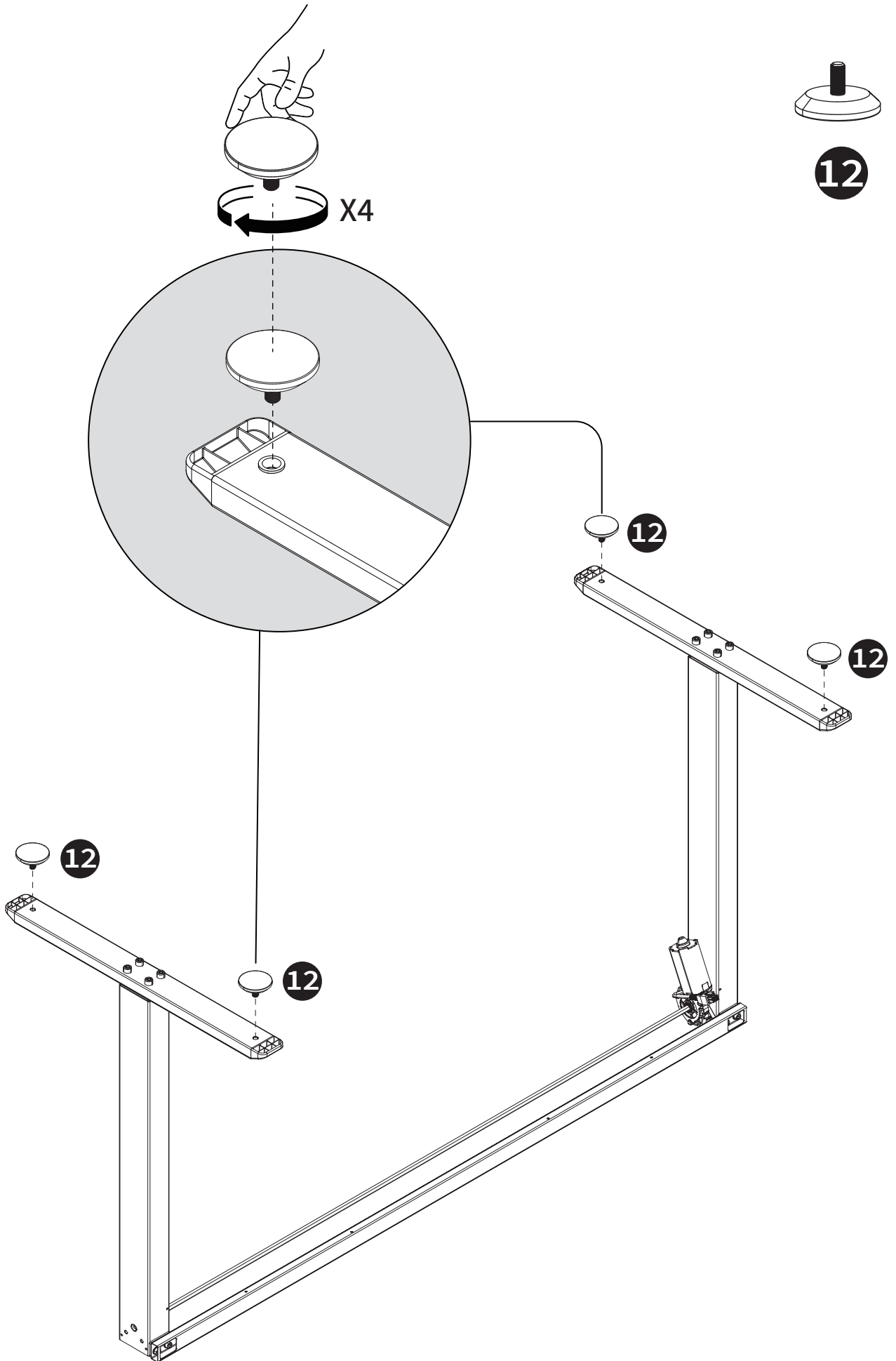

8

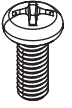

M4X10

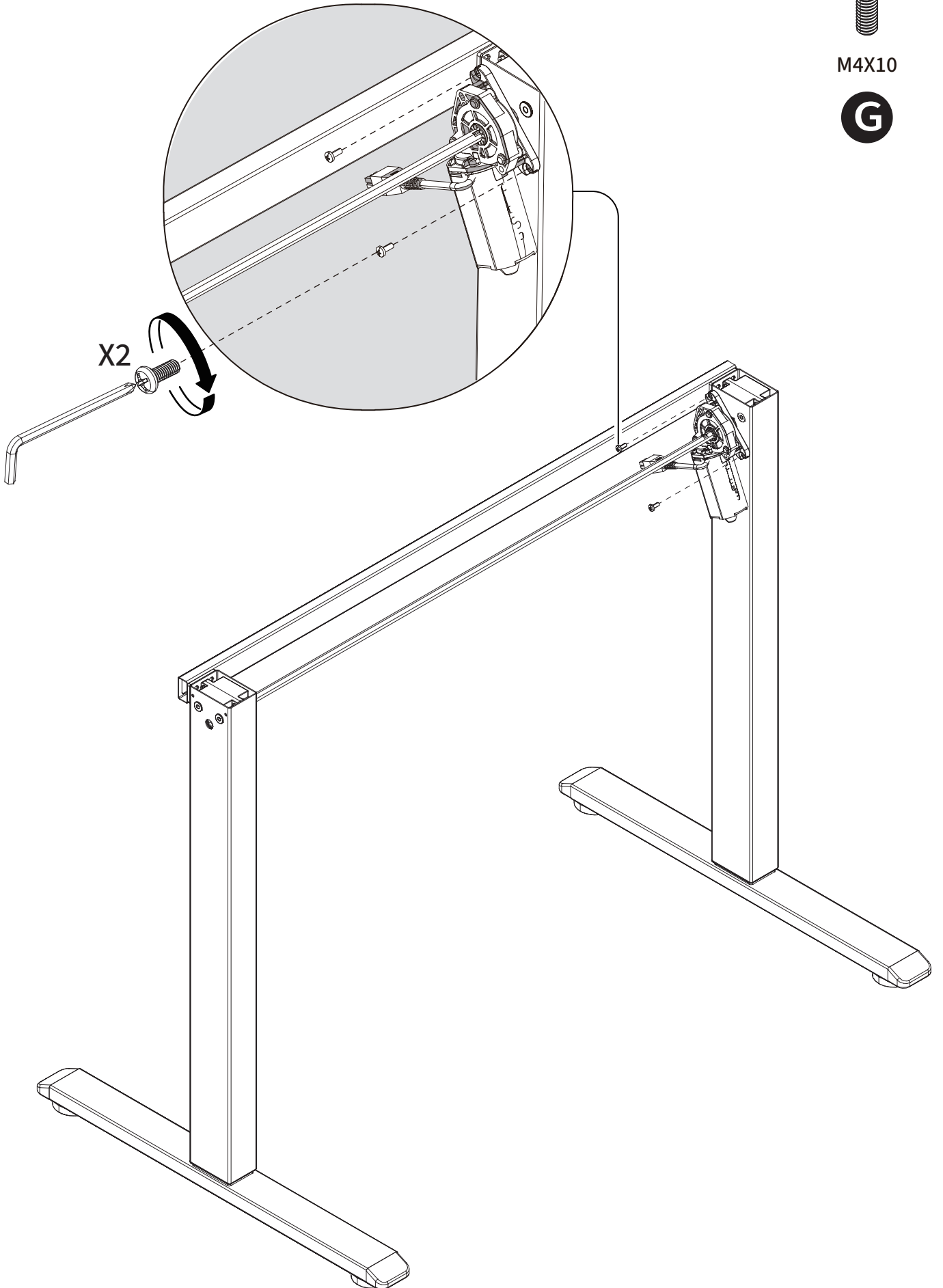

X2

9

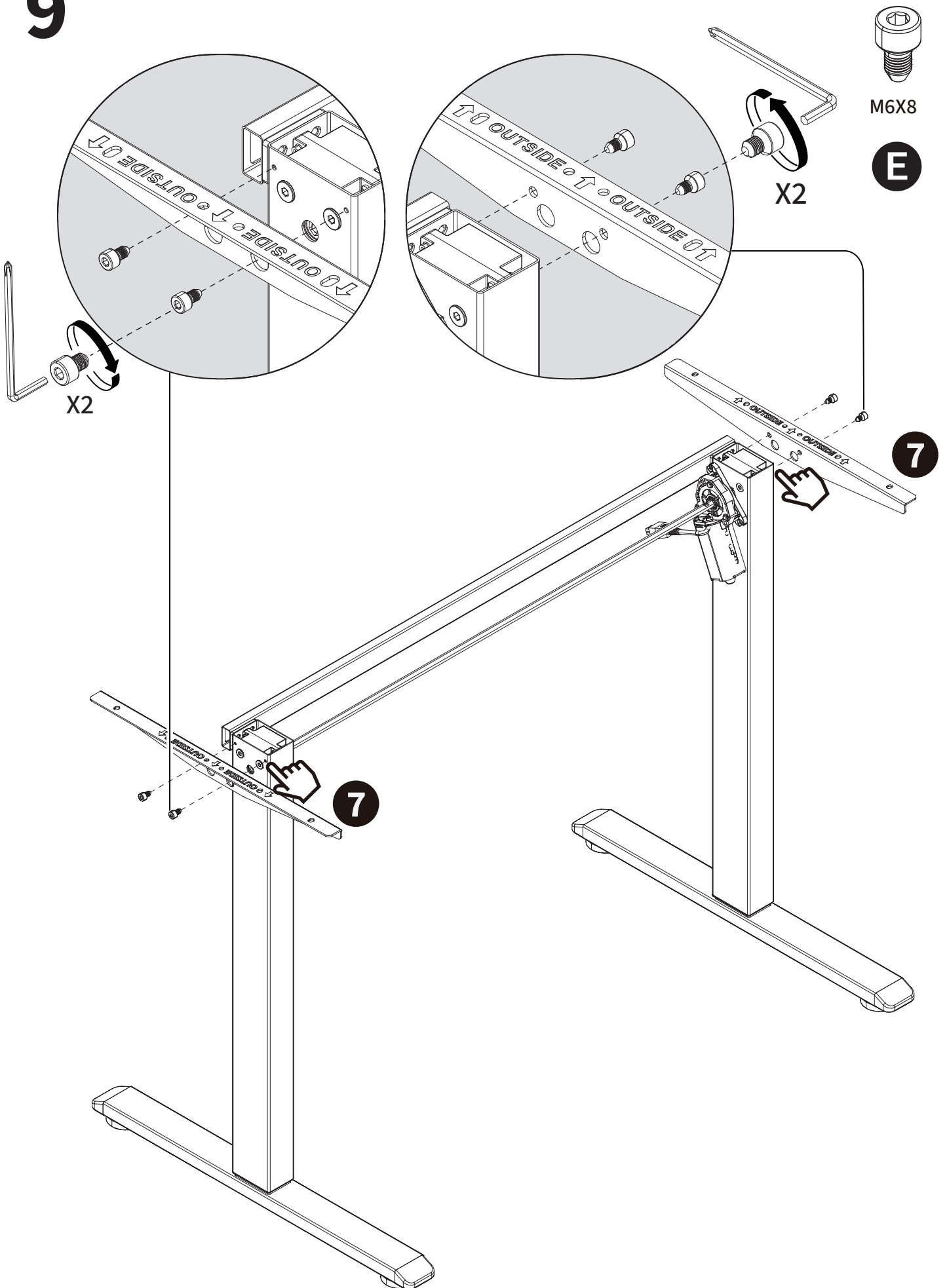

10

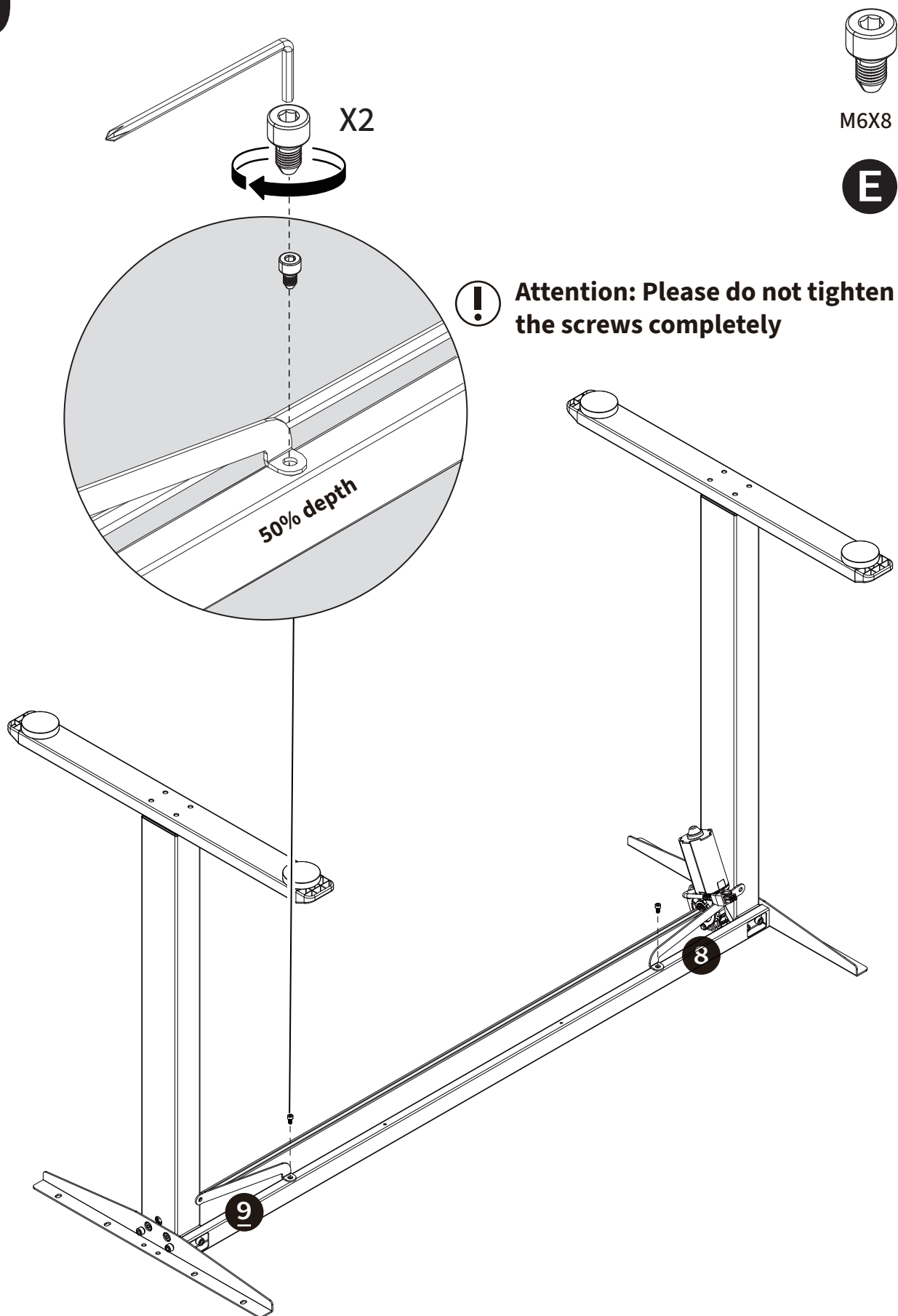

11

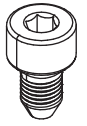

M6X8

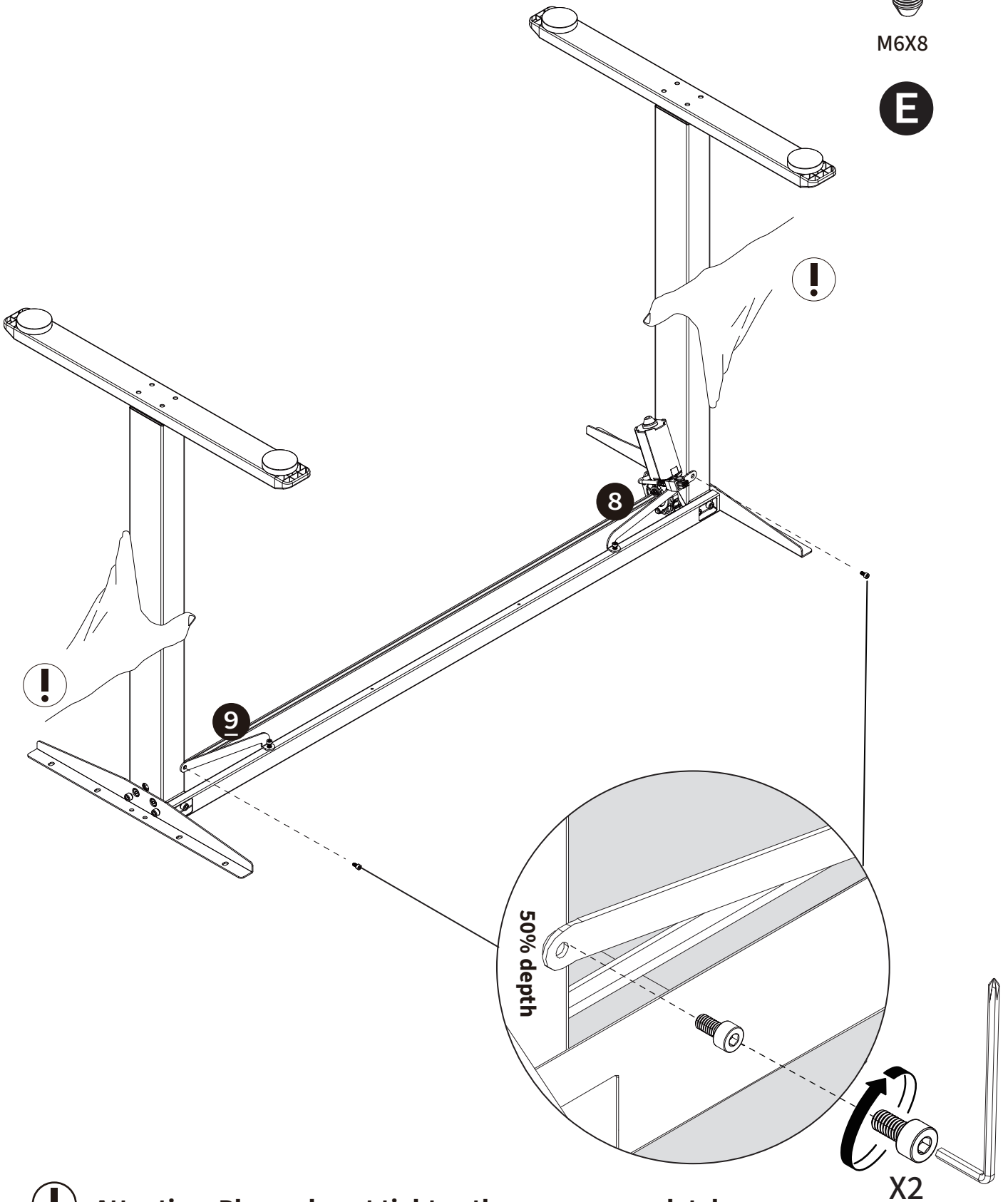

 **Attention: Please do not tighten the screws completely**

12

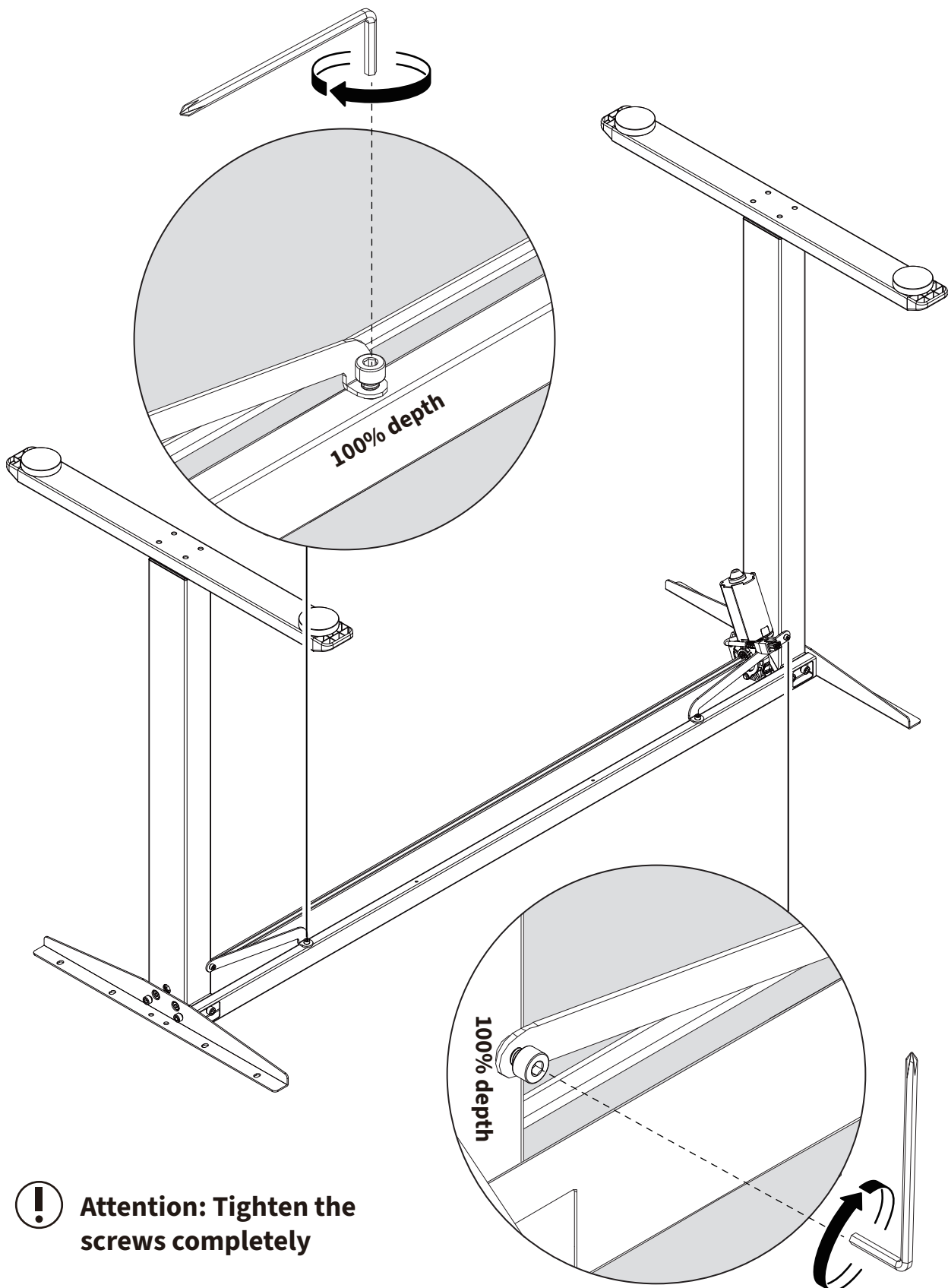

13

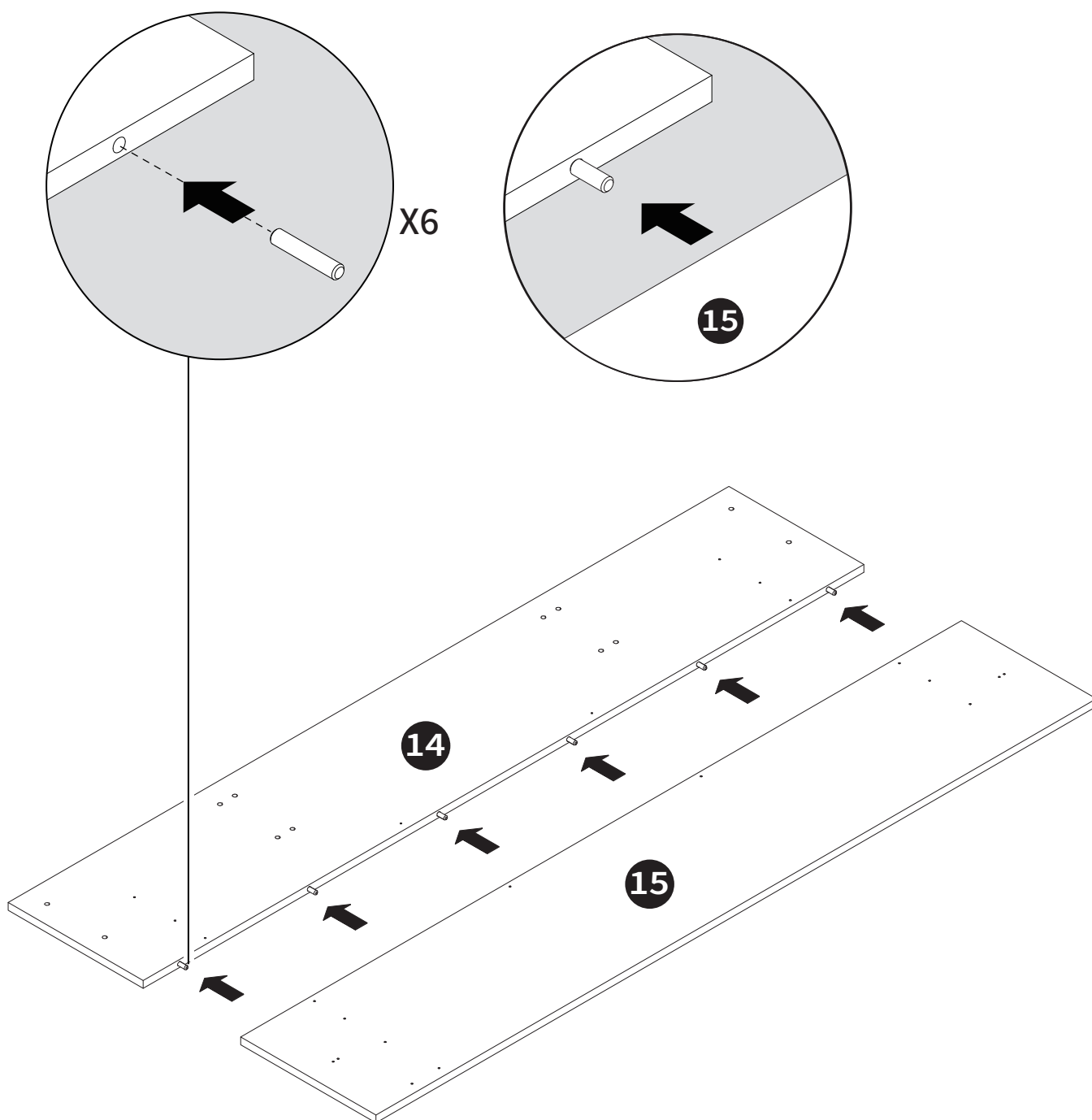
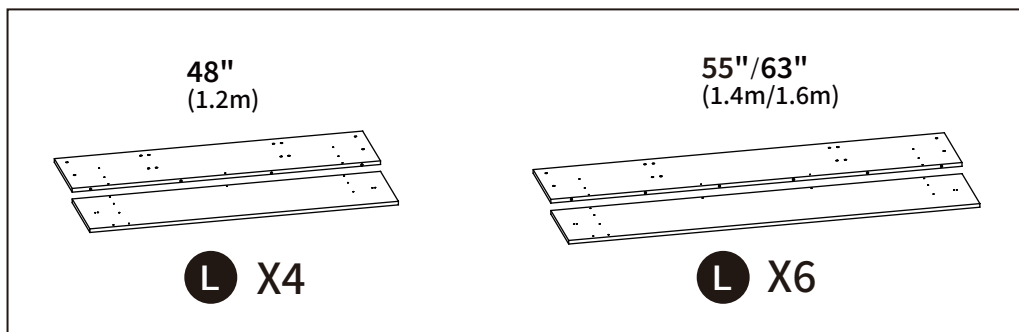

14

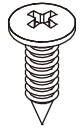
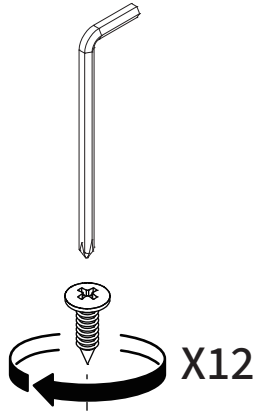

ST4.8X13

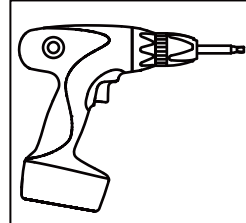

Attention:The recommended torque gear of the electric screwdriver is between 8 and 12.

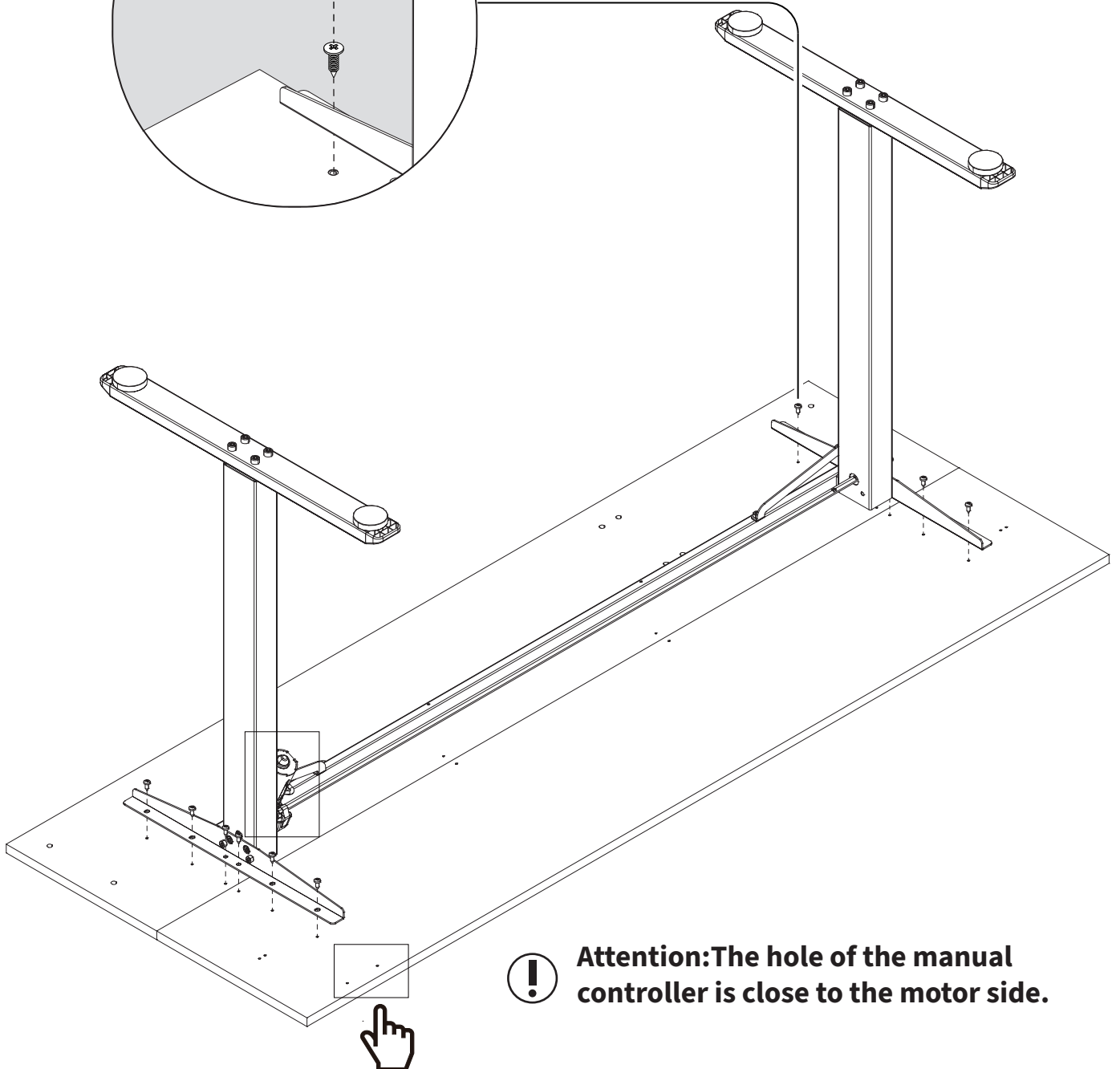
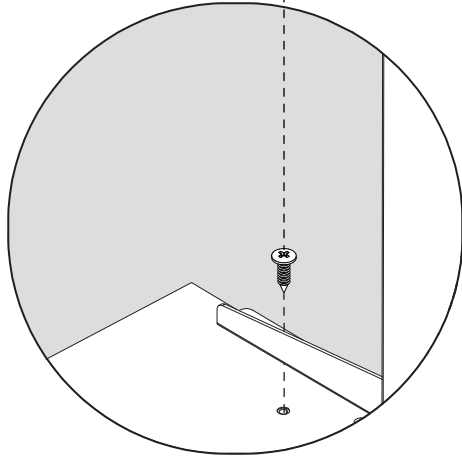

15

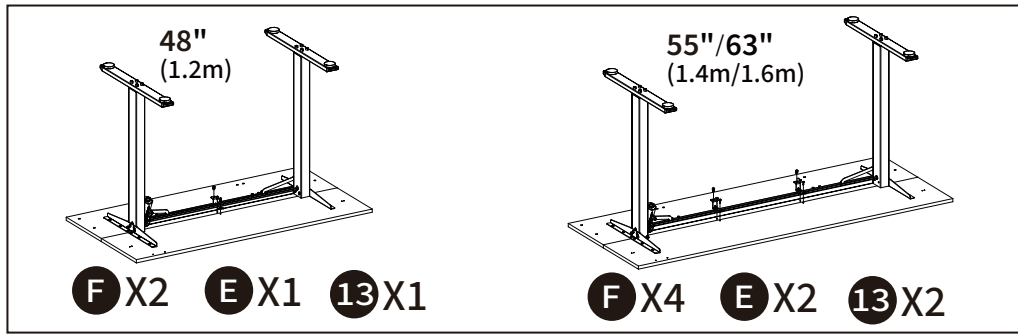

ST4.8X13

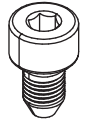

M6X8

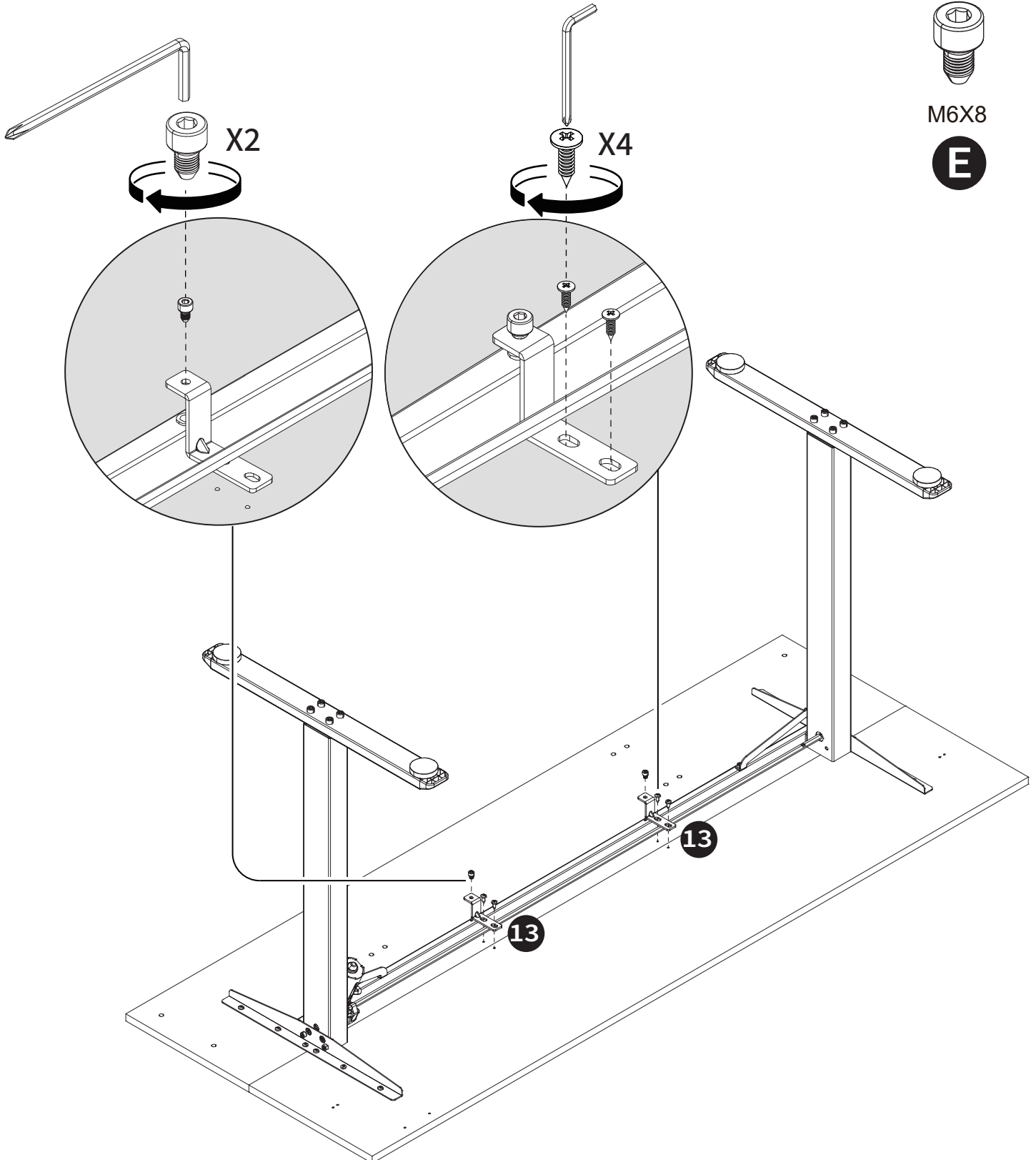

16

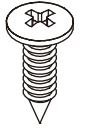

ST4.8X13

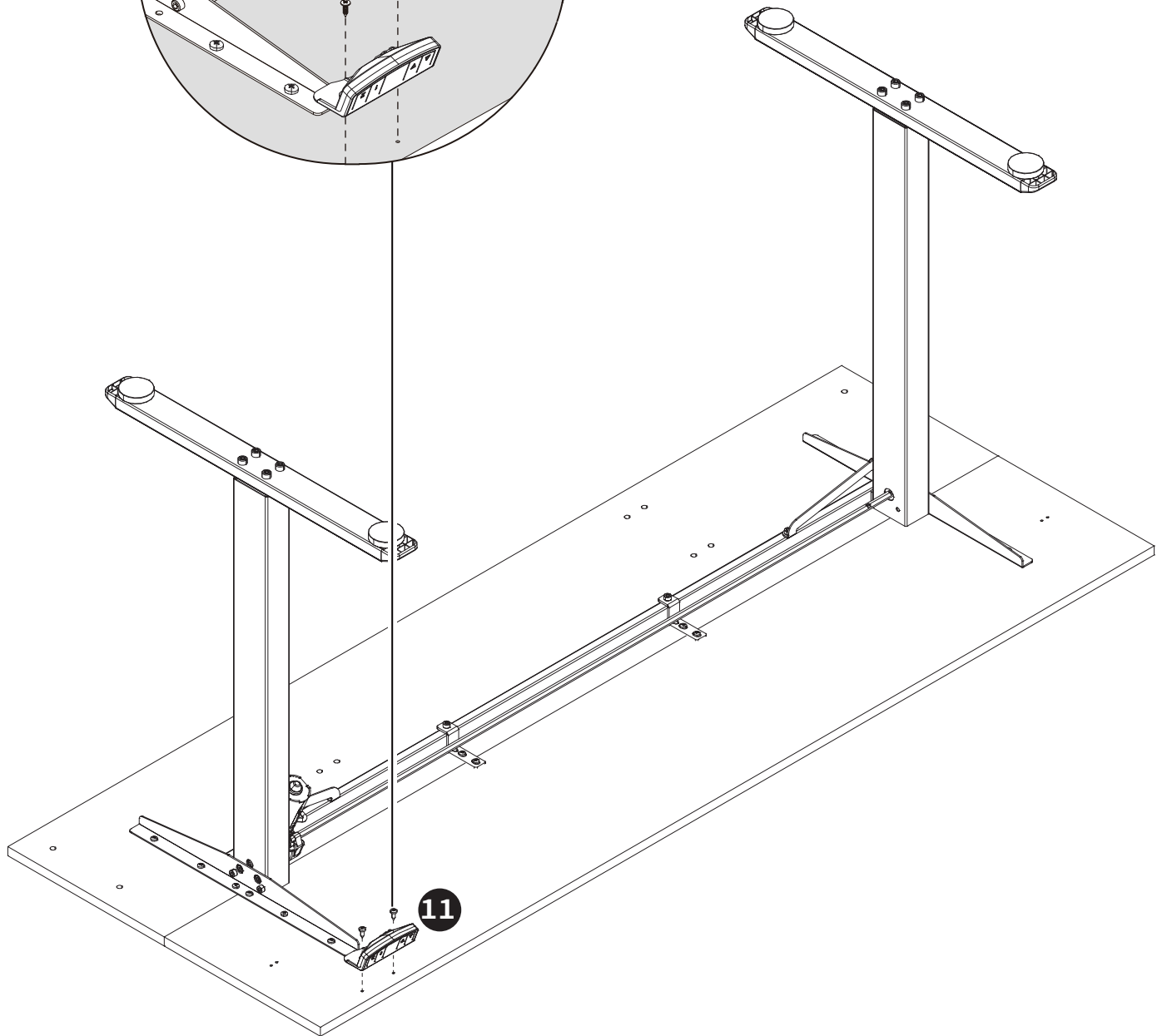
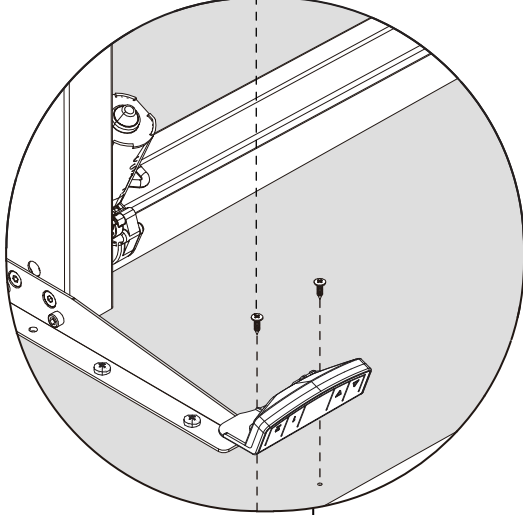
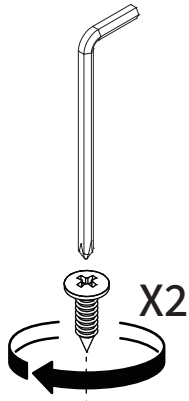

17

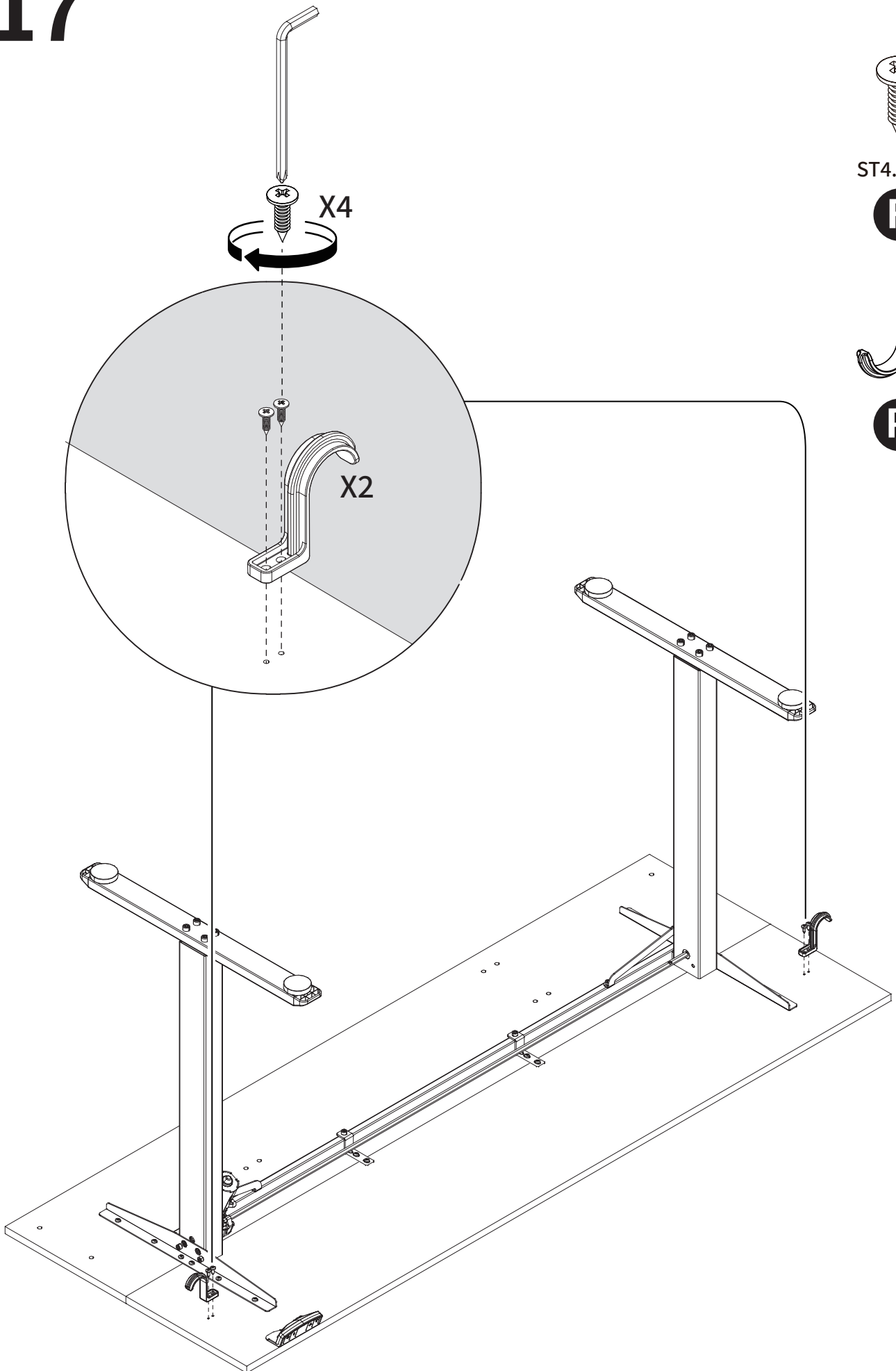

ST4.8X13

F

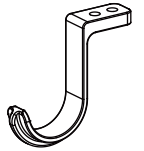

P

18

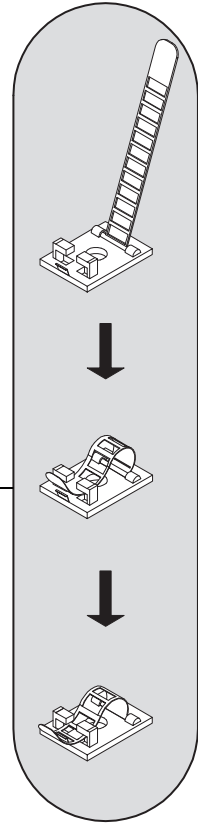
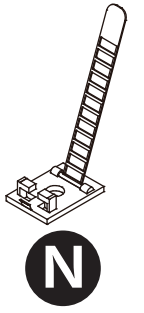
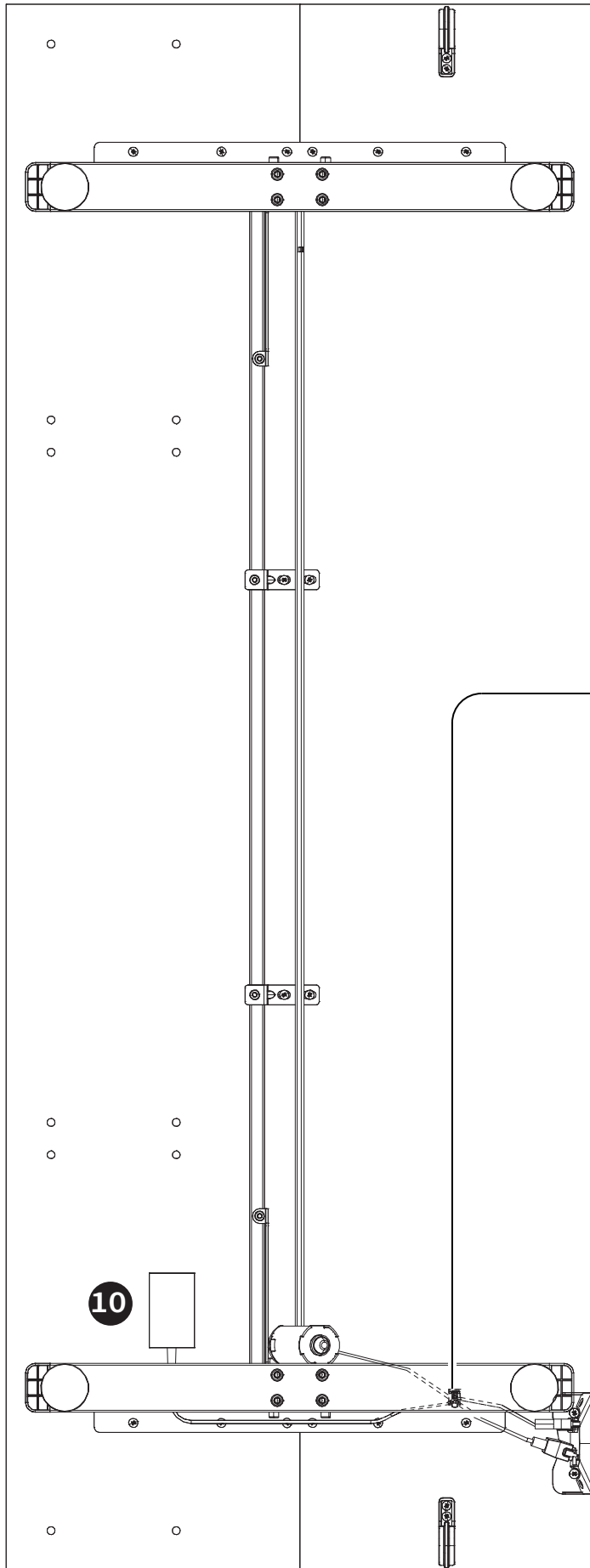

X3

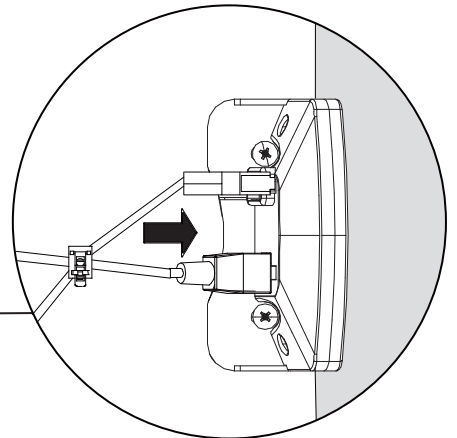

19



φ6X40

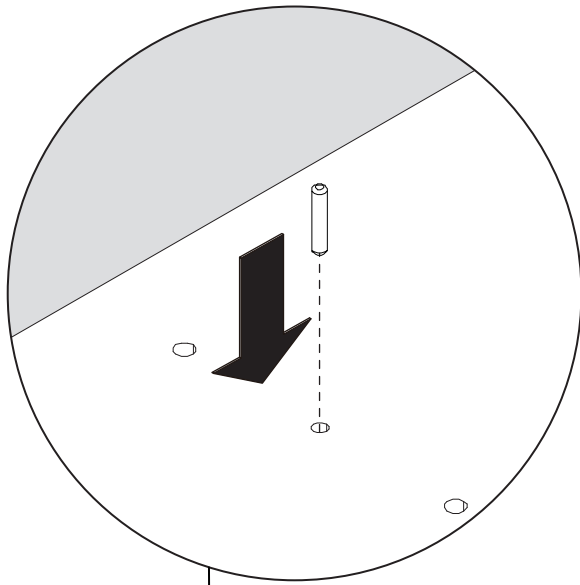

X2

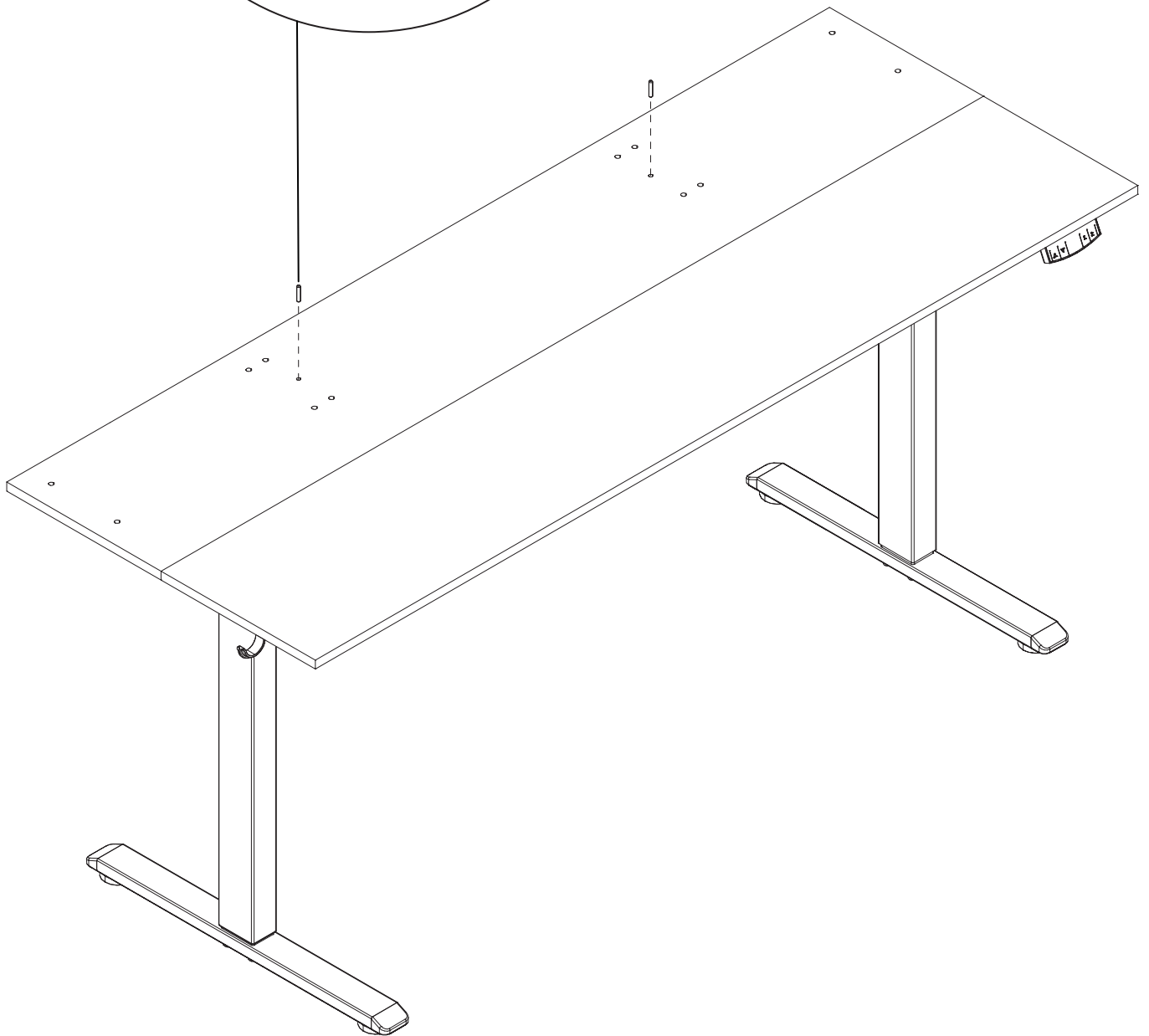

20

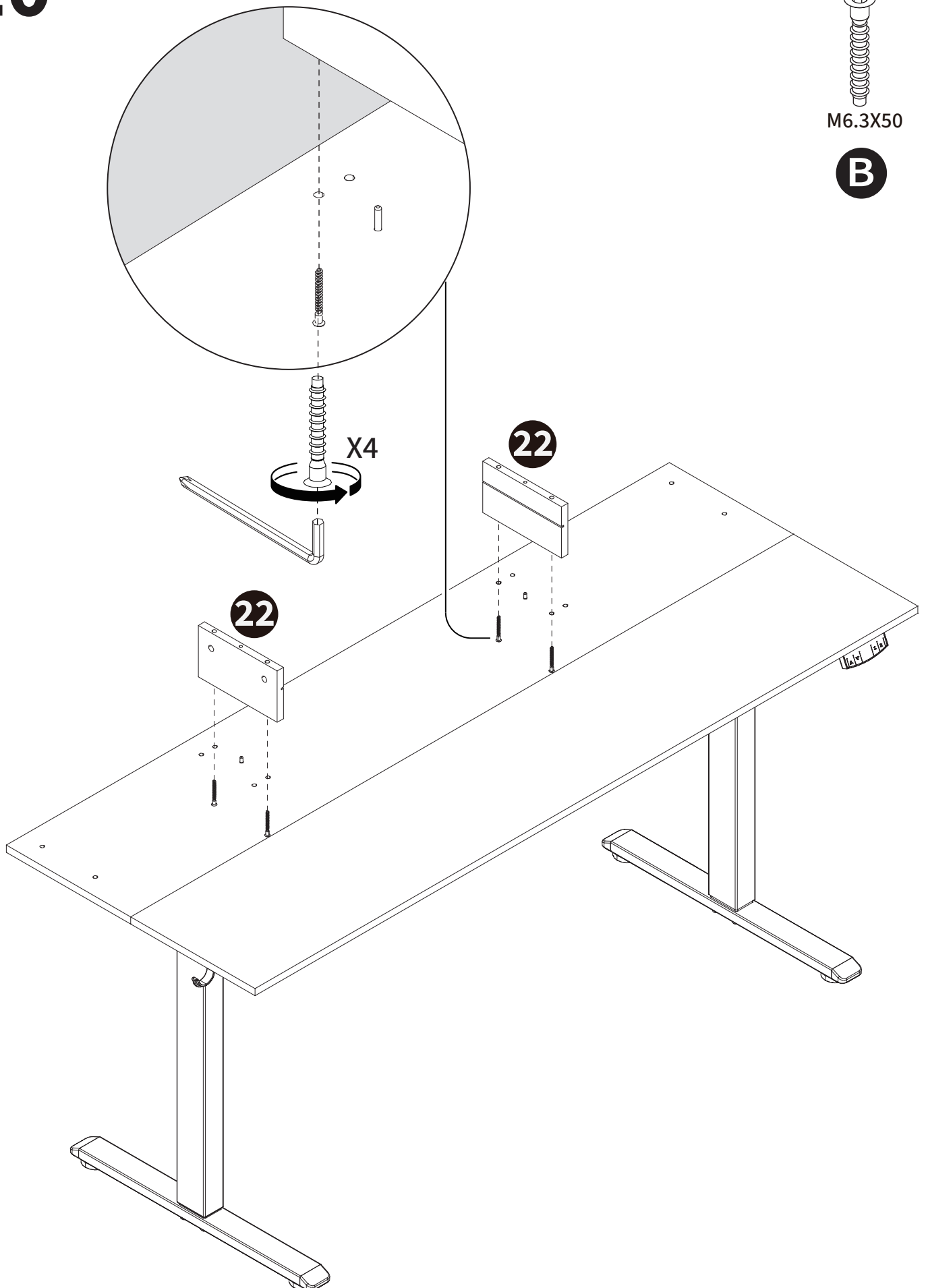

21

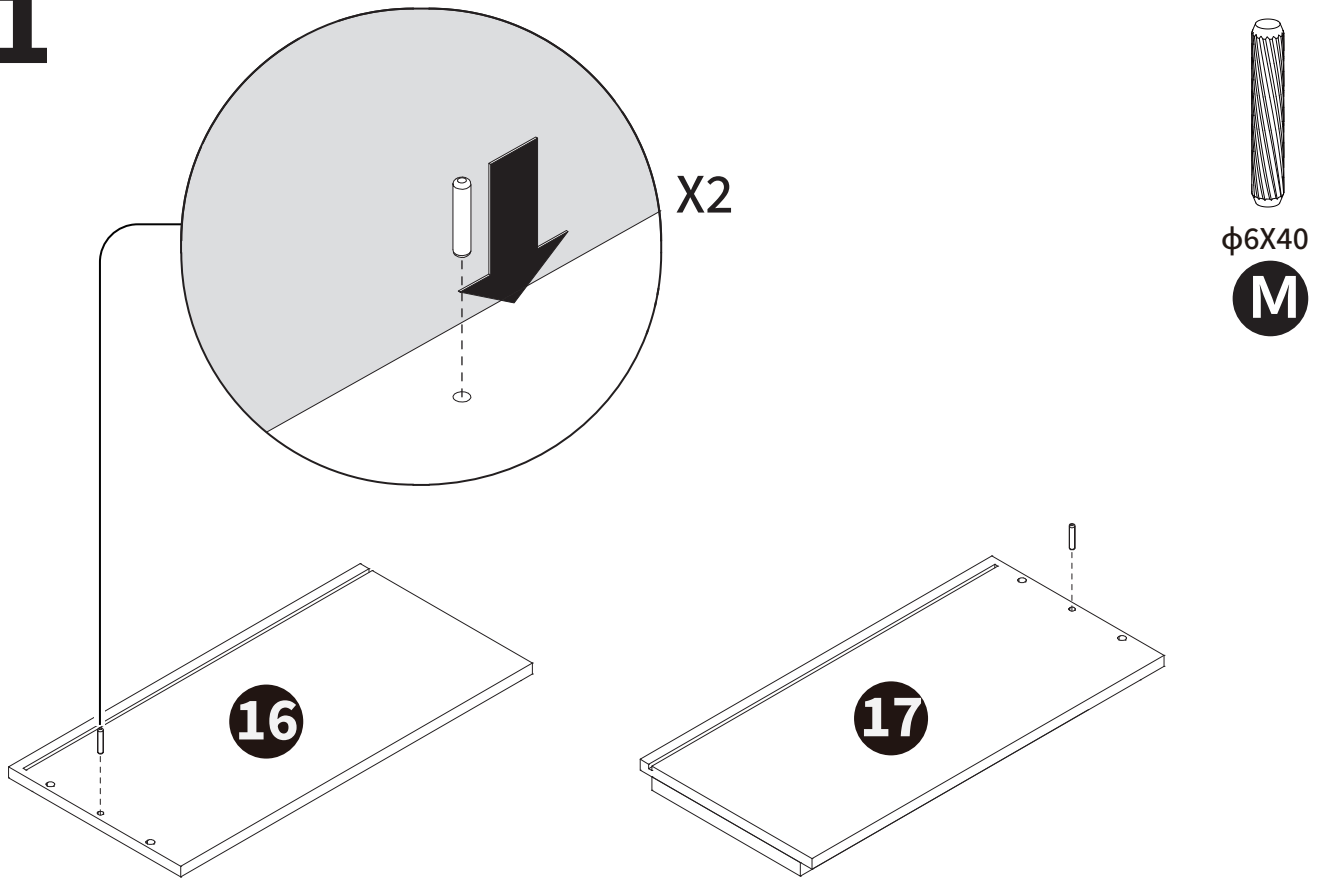

22

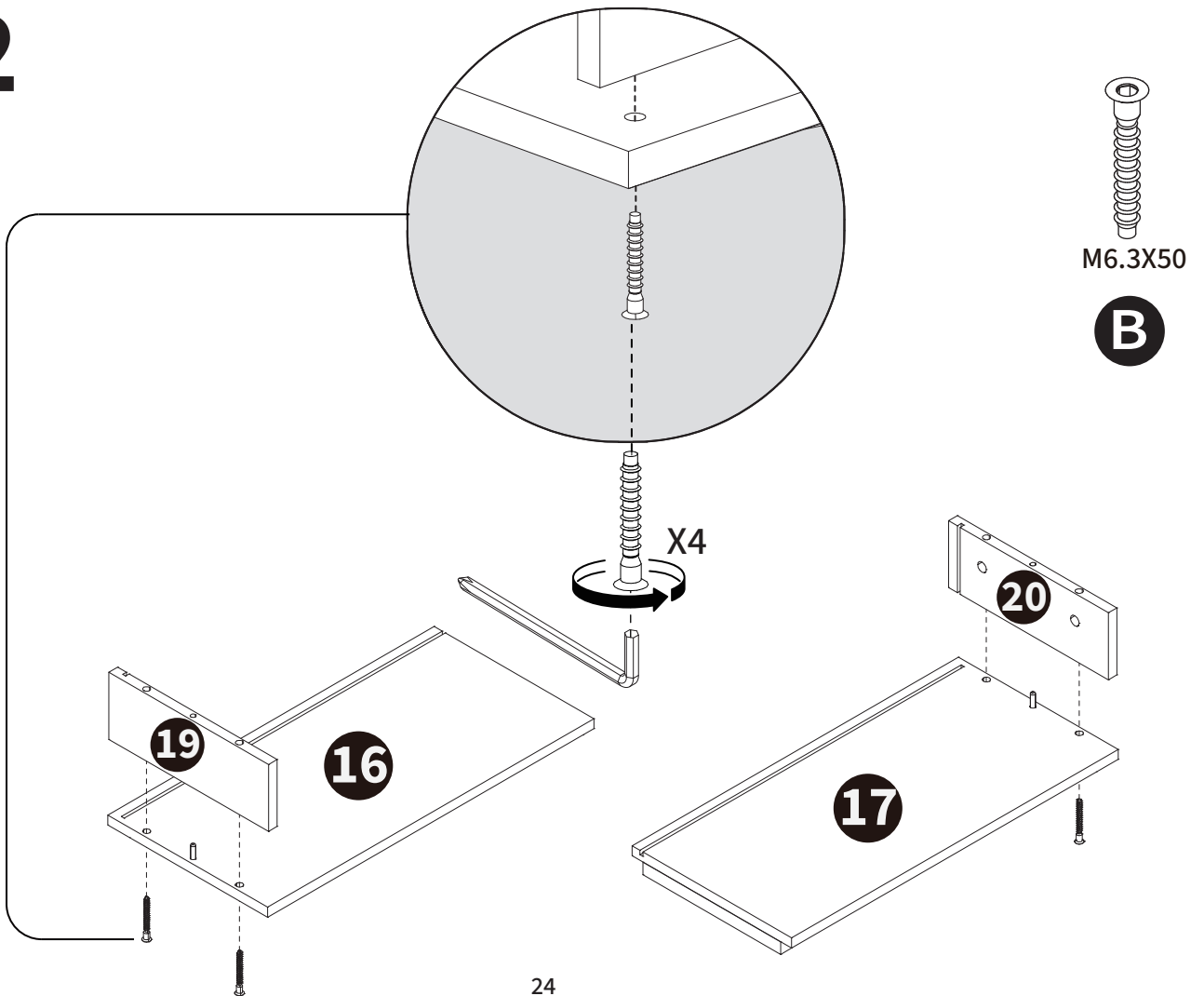

23

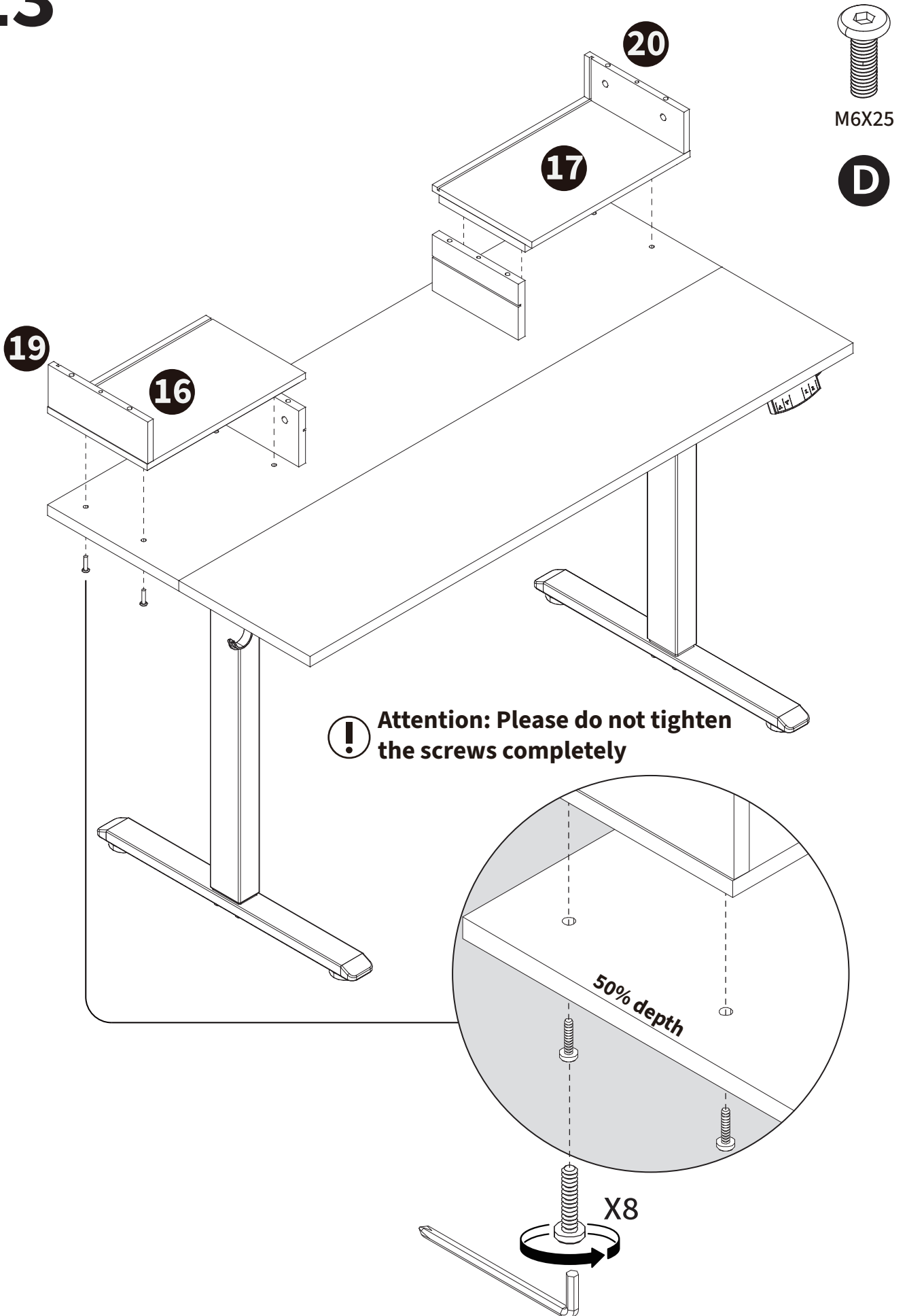

24

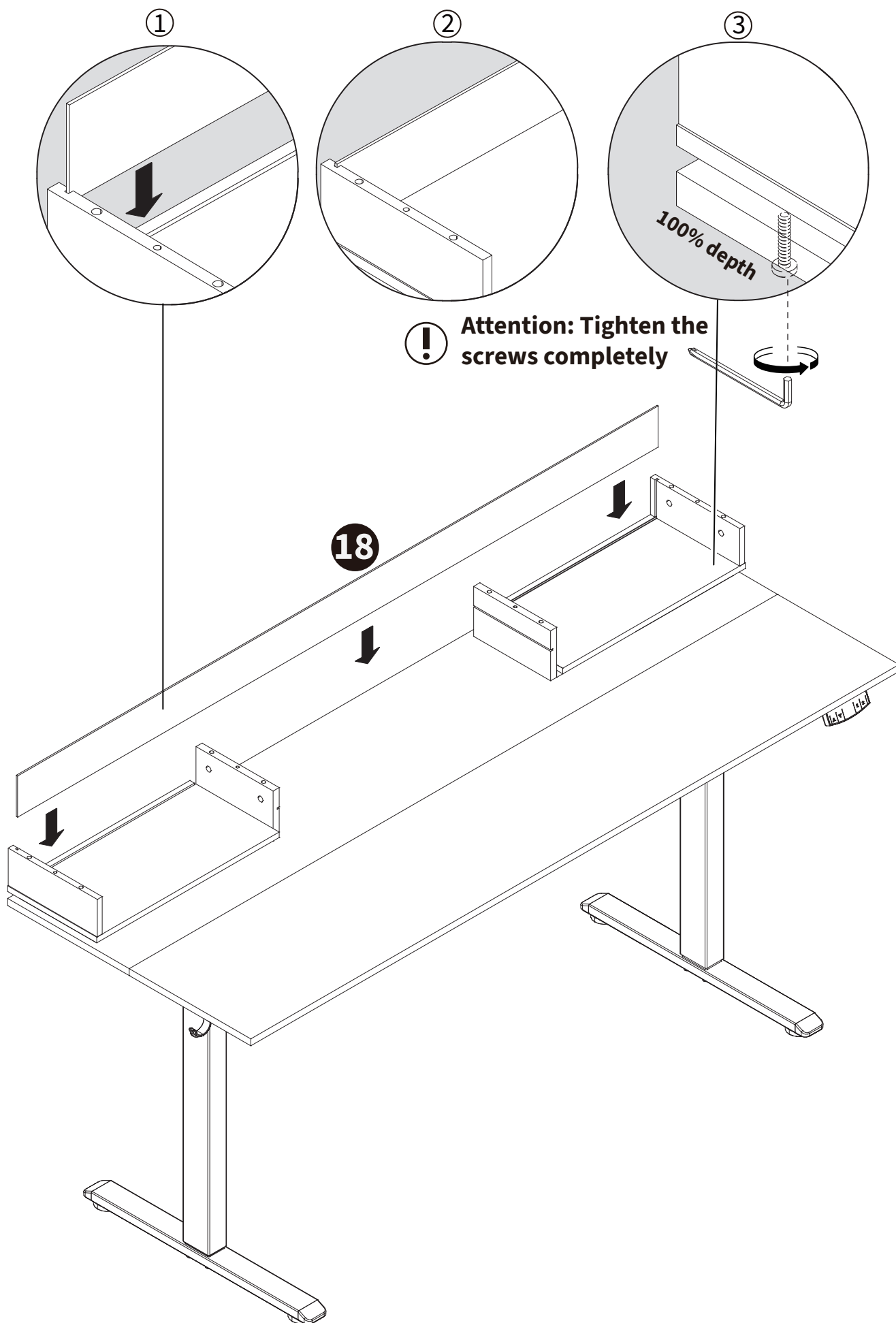

25

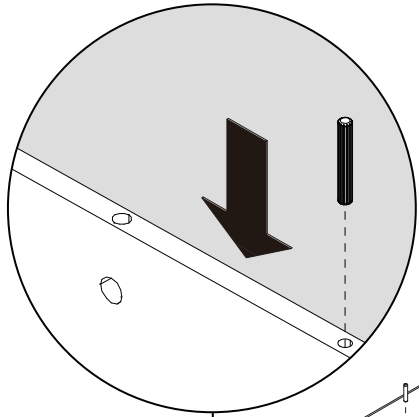

X4

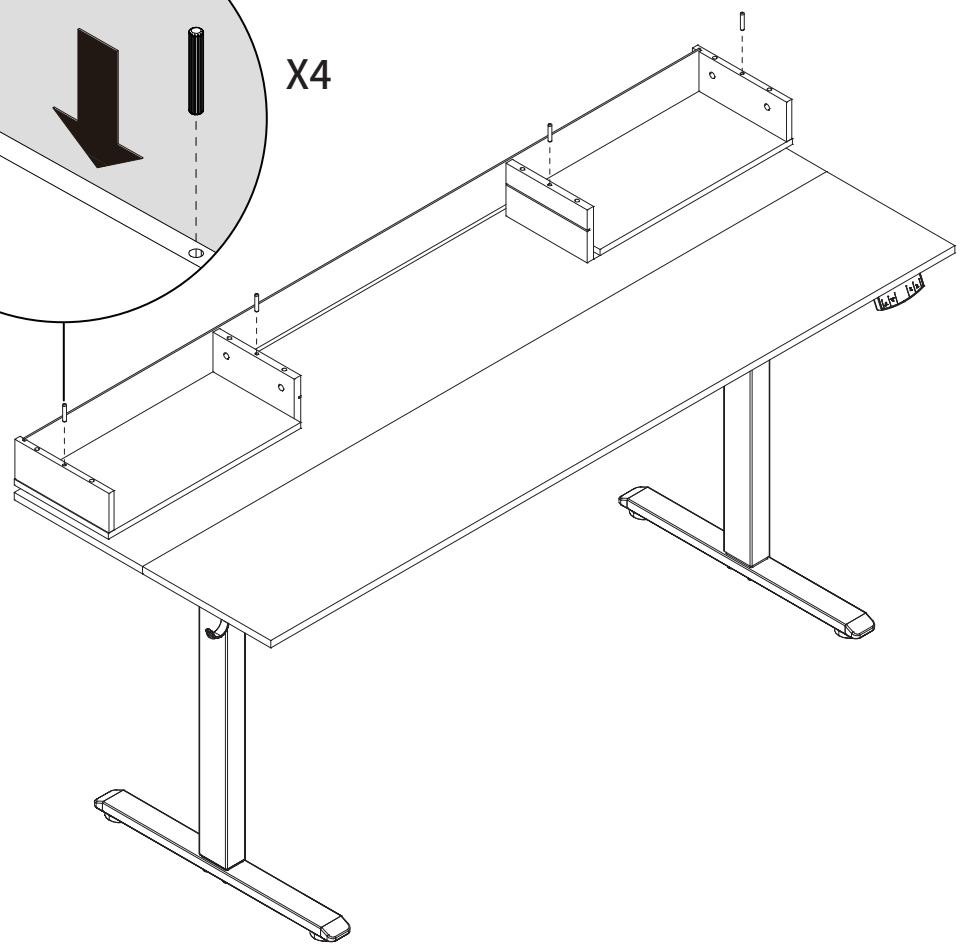

26

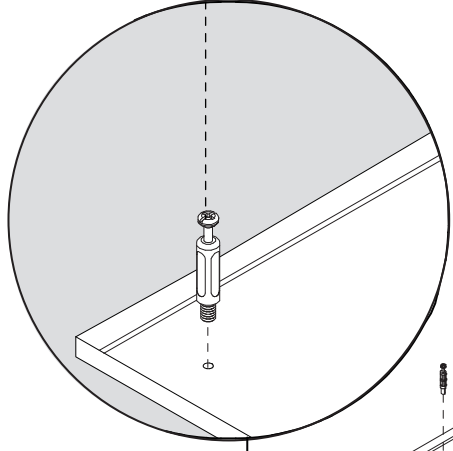
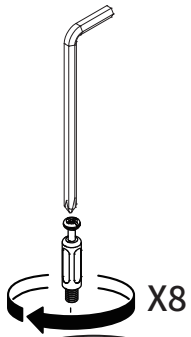

X8

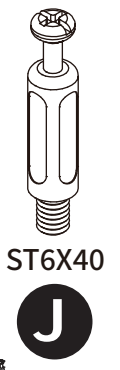
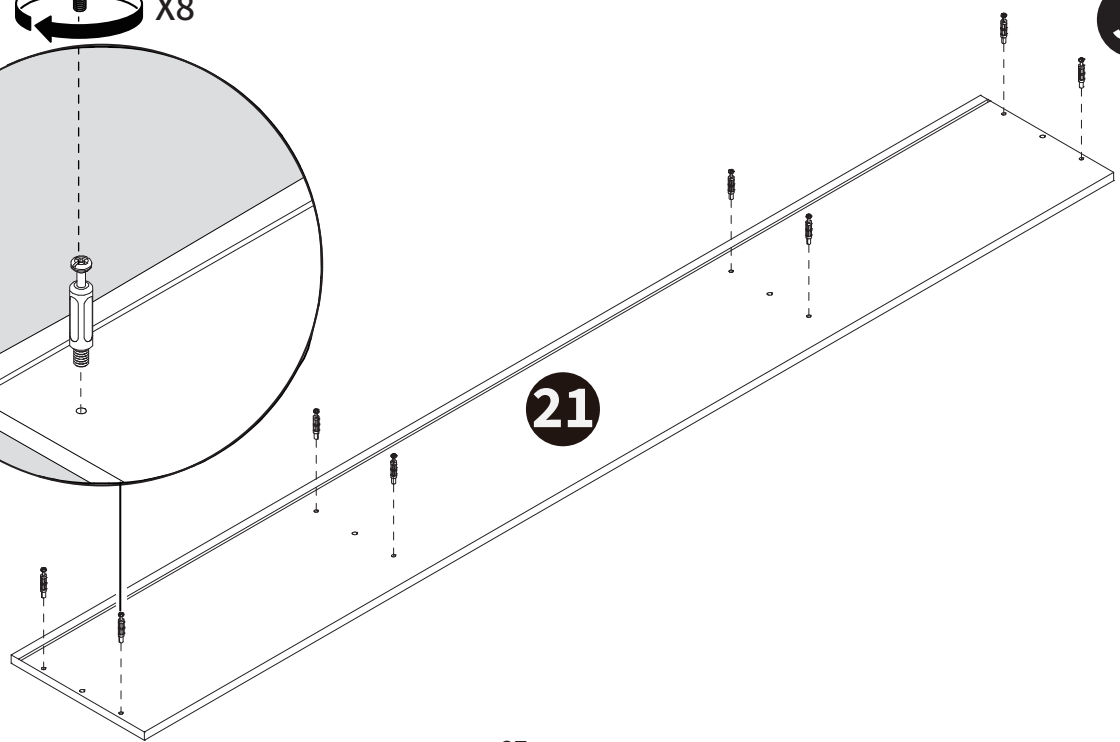

27

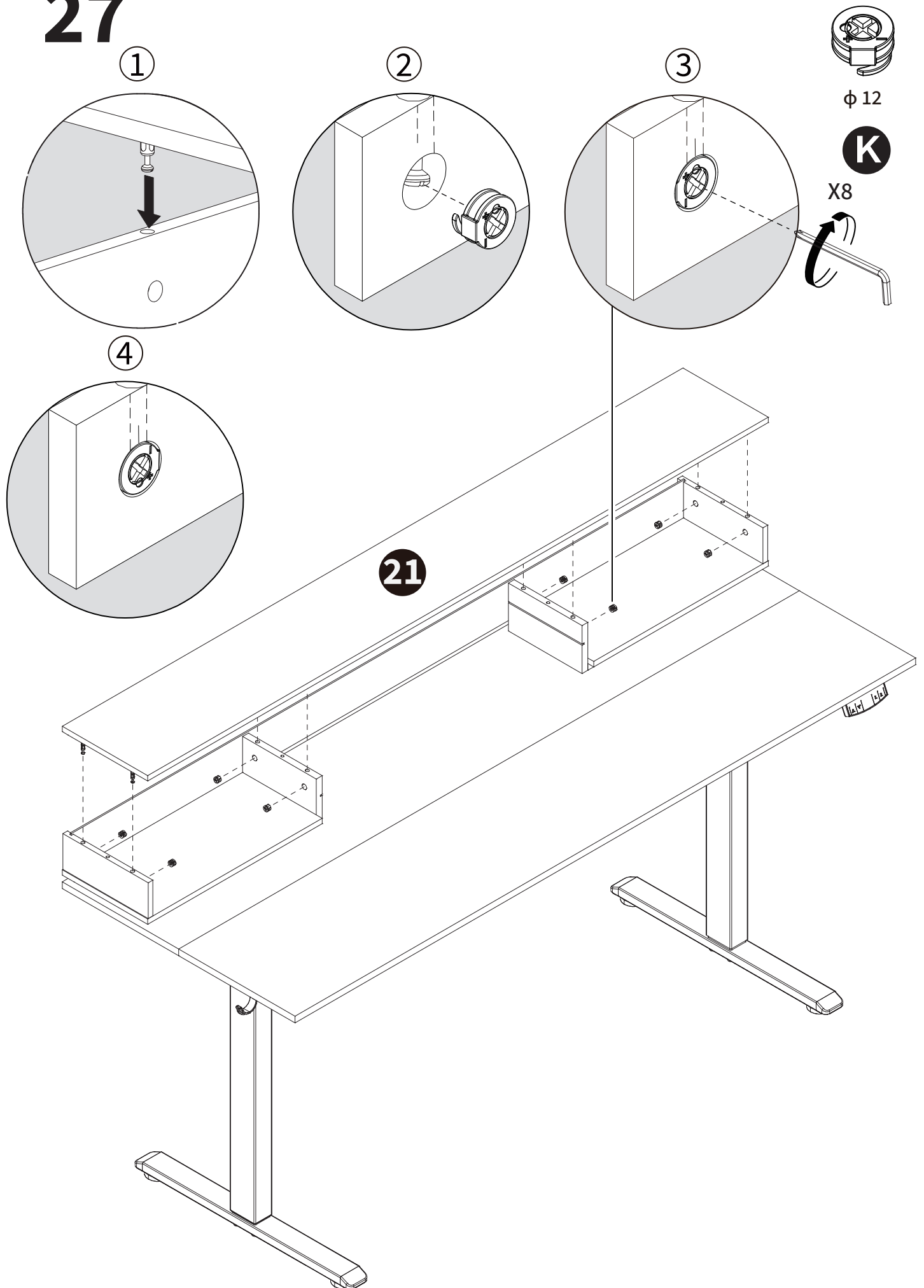

28

①

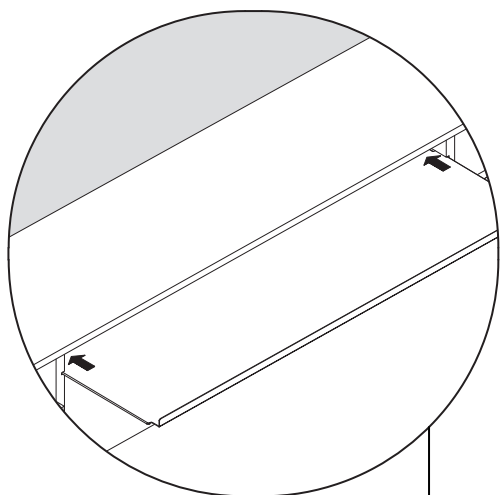

②

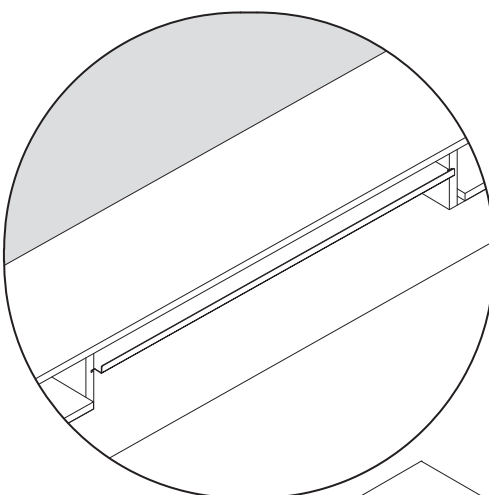

23

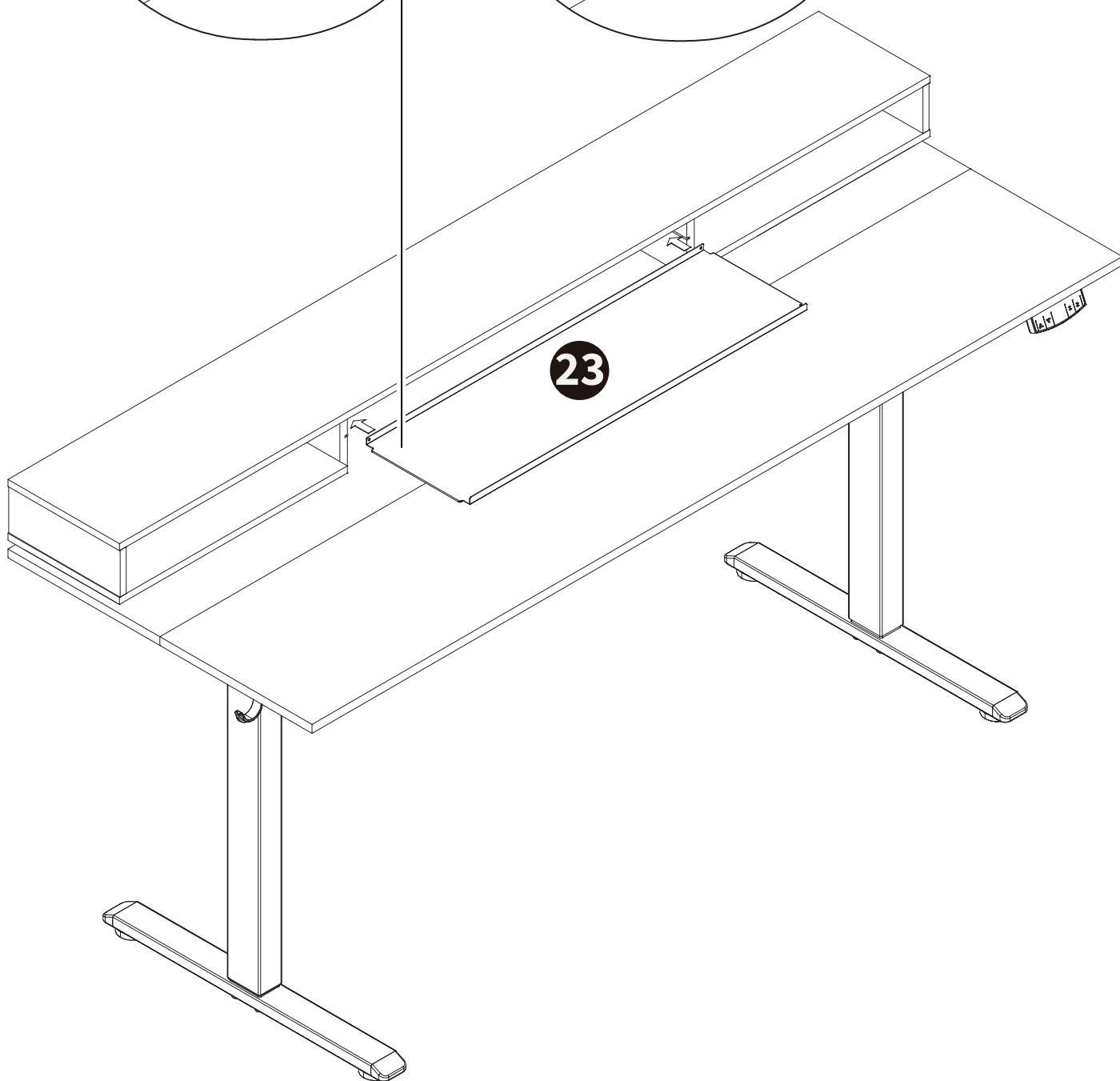

29

①

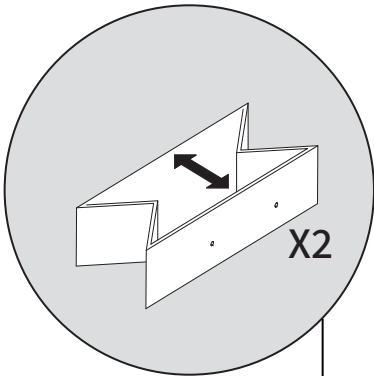

②

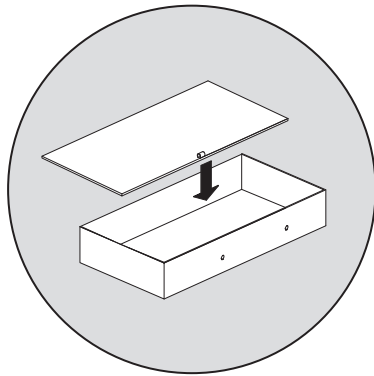

③

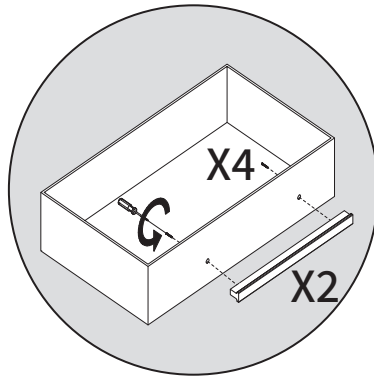

M4X6

H

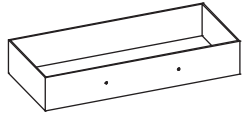

Q



R

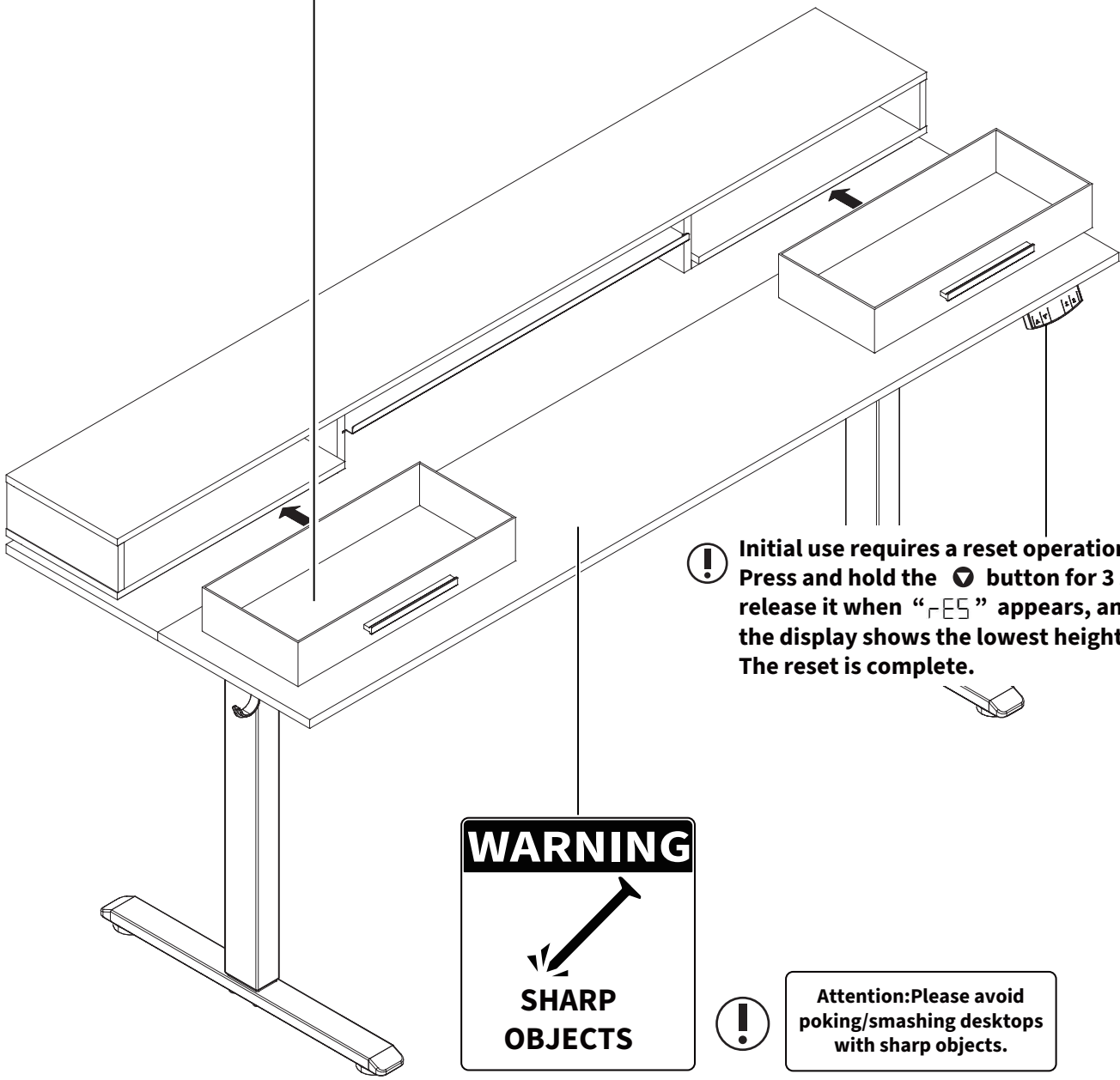

⚠ Initial use requires a reset operation: Press and hold the  button for 3 seconds, release it when "RES" appears, and wait until the display shows the lowest height value. The reset is complete.



WARNING



SHARP OBJECTS



⚠ Attention: Please avoid poking/smashing desktops with sharp objects.

Controller Operation Instructions

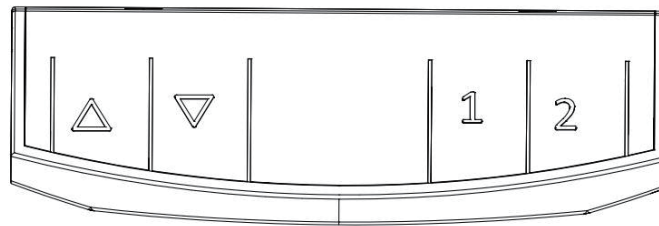

English(EN)

Using the controller

Raise the desktop	Press and hold the ▲ key to raise the desktop,and the table will stop moving when the key is released once the surface reaches the suitable height,or it will stop automatically when it reaches the highest position.
Lower the desktop	Press and hold the ▼ key to lower the desktop,and the table will stop moving when the key is released once the surface reaches the suitable height,or it will stop automatically when it reaches the lowest position.
Save current height setting	After adjusting the height-adjustable desk to the appropriate height, press and hold the key ① or ② for more than two seconds and then flash H1 or H2, and the height will be remembered on the ① or ② key
Memory height	In the height display interface,press ① or ② keys shortly then release,the standing table will automatically run to the memory height previously set for this key.
Power saving	If there is no key operation for a long time,the digital tube will automatically go out.At this time,press any key to light up the digital tube.

Setting menu

<p>Anti-Collision Protection Setting:</p> <p>On the control panel, press and hold both the ① and ② keys for two seconds. The current force level triggering the anti-collision protection will flash, and after three seconds, the current height will be displayed. During the flashing period, pressing any key will display the current height.</p> <p>If you need to adjust to the next target force value, simply repeat the above operation. There are 4 force levels, and the adjustment cycle is as follows: Off (off), H (heavy), N (normal), L (light).</p>
<p>Restore factory settings:</p> <p>In the cases that the "E10,E20" alarm state or after running to the lowest height position,long press the ▼ key for 3 seconds,then release when "rE5" is displayed.The standing desk will move down to the lowest and bounce to a certain height,the lowest height will be displayed on the screen once the reset completes.Please notice that a stroke reset is required when the power is off for the first time.</p>

Protection and Alarm

<p>Anti-collision protection: E02</p>	<p>During the lifting process, if the desk vibrates, experiences a collision, or tilts, the system will trigger an alarm and immediately move in the opposite direction for a preset distance before automatically canceling the alarm. The alarm can also be canceled manually by pressing any key during the reverse movement.</p> <p>Before resuming operation, check and ensure that the desk does not experience excessive vibration, collide with obstacles, or tilt.</p>
<p>Overheat protection Hot</p>	<p>Overheat Protection: Prolonged operation may trigger the overheat protection. In such cases, you should disconnect the power supply and the controller, then reconnect them, or wait for 15 minutes before using it again.</p>
<p>Motor abnormality protection E10</p>	<p>Disconnect the power, recheck and ensure that the connection between the motor and the controller is reliable, then reconnect the power.</p>
<p>Overload protection E20</p>	<p>If this alarm occurs when running upward, heavy objects on the desktop should be moved before running again; if this alarm occurs when running downward, cut off the power, remove some heavy objects on the table, and then power on again.</p>
<p>Under voltage protection E31</p>	<p>In the case of power failure, re-check and ensure that the connection between the power supply and the controller is proper, and then re-power on.</p>
<p>Overvoltage protection E32</p>	<p>In the case of power failure, re-check and ensure that the connection between the power supply and the controller is proper, and then re-power on.</p>

Verwendung des Controllers

Heben Sie den Schreibtisch an	Drücken und halten Sie die "▲"-Taste, um den Schreibtisch zu heben. Der Tisch wird anhalten, wenn die Taste losgelassen wird, sobald die Oberfläche die geeignete Höhe erreicht hat, oder er wird automatisch stoppen, wenn er die höchste Position erreicht hat.
Senken Sie den Schreibtisch ab	Drücken und halten Sie die "▼"-Taste, um den Schreibtisch zu senken. Der Tisch wird anhalten, wenn die Taste losgelassen wird, sobald die Oberfläche die geeignete Höhe erreicht hat, oder er wird automatisch stoppen, wenn er die niedrigste Position erreicht hat.
Aktuelle Höheneinstellung speichern	Nachdem Sie den Höhenverstellbaren Tisch auf die gewünschte Höhe eingestellt haben, halten Sie die Taste ① oder ② länger als zwei Sekunden gedrückt, bis H1 oder H2 blinkt. Diese Höhe wird dann auf der Taste ① oder ② gespeichert.
Gedächtnishöhe	Drücken Sie in der Höhenanzeige-Schnittstelle kurz die Tasten ① oder ② und lassen Sie sie dann los. Der Stehtisch wird automatisch zur zuvor für diesen Schlüssel eingestellten Speicherhöhe fahren.
Strom sparen	Wenn keine Taste lange Zeit nicht betätigt wird, wird die digitale Röhre automatisch ausgehen. Drücken Sie zu diesem Zeitpunkt eine beliebige Taste, um die digitale Röhre zu beleuchten.

Setting menu

<p>Anti-Collision-Schutz-Einstellung:</p> <p>Drücken und halten Sie gleichzeitig die Tasten ① und ② für zwei Sekunden. Die aktuelle Krafteinstellung, die den Anti-Kollisionsschutz auslöst, wird blinken, und nach drei Sekunden wird die aktuelle Höhe angezeigt. Während des Blinkvorgangs zeigt das Drücken einer beliebigen Taste die aktuelle Höhe an.</p> <p>Wenn Sie den nächsten Zielwert für die Kraft einstellen möchten, wiederholen Sie einfach die oben beschriebene Vorgehensweise. Es gibt 4 Kraftstufen, und der Anpassungszyklus lautet wie folgt: Off (aus), H (schwer), N (normal), L (leicht).</p>
<p>Werkseinstellungen wiederherstellen:</p> <p>Drücken Sie in den Fällen, in denen der "E10, E20"-Alarmzustand vorliegt oder nachdem der niedrigste Höhenposition erreicht wurde, die "▼"-Taste für 3 Sekunden, und lassen Sie sie dann los, wenn "rE5" angezeigt wird. Der Stehtisch wird sich zur niedrigsten Position bewegen und auf eine bestimmte Höhe springen. Die niedrigste Höhe wird auf dem Bildschirm angezeigt, sobald das Zurücksetzen abgeschlossen ist. Bitte beachten Sie, dass ein Hubreset erforderlich ist, wenn der Strom zum ersten Mal ausgeschaltet wird.</p>

Protection and Alarm

<p>Anti Kollisionsschutz E02</p>	<p>Während des Hebevorgangs, wenn der Schreibtisch vibriert, auf ein Hindernis stößt oder sich neigt, löst das System einen Alarm aus und bewegt sich sofort für eine voreingestellte Strecke in die entgegengesetzte Richtung, bevor der Alarm automatisch aufgehoben wird.</p> <p>Der Alarm kann auch manuell durch Drücken einer beliebigen Taste während der Rückwärtsbewegung aufgehoben werden.</p> <p>Bevor Sie den Betrieb fortsetzen, überprüfen Sie, ob der Schreibtisch keine übermäßigen Vibrationen erfährt, mit Hindernissen kollidiert oder sich neigt.</p>
<p>überhitzen-Schützen Hot</p>	<p>Überhitzungsschutz: Längerer Betrieb kann den Überhitzungsschutz auslösen. In diesem Fall sollten Sie die Stromversorgung und den Controller trennen, dann wieder verbinden oder 15 Minuten warten, bevor Sie das Gerät erneut verwenden.</p>
<p>Schutz vor Motoranomalien E10</p>	<p>Trennen Sie die Stromversorgung, überprüfen Sie erneut und stellen Sie sicher, dass die Verbindung zwischen dem Motor und dem Controller zuverlässig ist, und schließen Sie dann die Stromversorgung wieder an.</p>
<p>Überlast-Schützen E20</p>	<p>Wenn dieser Alarm beim Hochlaufen auftritt, sollten schwere Gegenstände auf dem Schreibtisch bewegt werden, bevor er erneut gestartet wird. Wenn dieser Alarm beim Abwärtslaufen auftritt, schalten Sie die Stromversorgung aus, entfernen Sie einige schwere Gegenstände auf dem Tisch und schalten Sie dann erneut ein.</p>
<p>Schutz vor Unterspannung E31</p>	<p>Im Falle eines Stromausfalls überprüfen Sie bitte und stellen Sie sicher, dass die Verbindung zwischen der Stromversorgung und dem Controller korrekt ist, und schalten Sie dann erneut ein.</p>
<p>Schutz vor Überspannung E32</p>	<p>Im Falle eines Stromausfalls überprüfen Sie bitte und stellen Sie sicher, dass die Verbindung zwischen der Stromversorgung und dem Controller korrekt ist, und schalten Sie dann erneut ein.</p>

Soulevez le bureau	Appuyez et maintenez la touche "▲" pour soulever le bureau, et la table s'arrêtera de bouger lorsque la touche sera relâchée une fois la surface atteignant la hauteur appropriée, ou elle s'arrêtera automatiquement lorsqu'elle atteindra la position la plus haute.
Abaissez le bureau	Appuyez et maintenez la touche "▼" pour abaisser le bureau, et la table s'arrêtera de bouger lorsque la touche sera relâchée une fois la surface atteignant la hauteur appropriée, ou elle s'arrêtera automatiquement lorsqu'elle atteindra la position la plus basse.
Enregistrez la hauteur actuelle	Après avoir réglé le bureau réglable en hauteur à la hauteur souhaitée, maintenez enfoncé le bouton numérique ① ou ② pendant plus de deux secondes jusqu'à ce que H1 ou H2 clignote. Cette hauteur sera ensuite mémorisée sur le bouton ① ou ②.
Hauteur mémorisée	Dans l'interface d'affichage de la hauteur, appuyez brièvement sur les touches ① ou ②, puis relâchez-les. La table debout se déplacera automatiquement à la hauteur mémorisée précédemment définie pour cette touche.
Économie d'énergie	En l'absence d'opération de touche pendant longtemps, le tube numérique s'éteindra automatiquement. À ce moment-là, appuyez sur n'importe quelle touche pour allumer le tube numérique.

Menu de réglage

<p>Réglage de la protection anti-collision :</p> <p>Sur le panneau de commande, maintenez enfoncées les touches ① et ② pendant deux secondes. Le niveau de force actuel déclenchant la protection anti-collision clignotera, puis après trois secondes, la hauteur actuelle sera affichée. Pendant la période de clignotement, appuyer sur n'importe quelle touche affichera la hauteur actuelle.</p> <p>Si vous devez ajuster la valeur de force cible suivante, répétez simplement l'opération ci-dessus. Il y a 4 niveaux de force, et le cycle de réglage est le suivant : Off (désactivé), H (fort), N (normal), L (léger).</p>
<p>Restaurer les paramètres d'usine:</p> <p>Dans les cas où l'état d'alarme "E10, E20" est activé ou après être descendu à la position la plus basse, maintenez la touche "▼" enfoncée pendant 3 secondes, puis relâchez-la lorsque "rE5" s'affiche. La table debout descendra jusqu'à la position la plus basse et rebondira à une certaine hauteur, la hauteur la plus basse sera affichée à l'écran une fois la réinitialisation terminée. Veuillez noter qu'une réinitialisation de course est nécessaire lorsque l'alimentation est coupée pour la première fois.</p>

Protection et alarme

<p>Protection anti-collision E02</p>	<p>Pendant le processus de levage, si le bureau vibre, entre en collision avec un obstacle ou s'incline, le système déclenche une alarme et se déplace immédiatement dans la direction opposée sur une distance prédéfinie avant d'annuler automatiquement l'alarme.</p> <p>L'alarme peut également être annulée manuellement en appuyant sur n'importe quelle touche pendant le mouvement inverse.</p> <p>Avant de reprendre le fonctionnement, vérifiez et assurez-vous que le bureau ne vibre pas excessivement, ne heurte pas d'obstacles et ne s'incline pas.</p>
<p>Protection contre la surchauffe Hot</p>	<p>Protection contre la surchauffe : Un fonctionnement prolongé peut déclencher la protection contre la surchauffe. Dans ce cas, vous devez débrancher l'alimentation électrique et le contrôleur, puis les rebrancher, ou attendre 15 minutes avant de pouvoir l'utiliser à nouveau.</p>
<p>Protection contre les anomalies du moteur E10</p>	<p>Débranchez l'alimentation, vérifiez à nouveau et assurez-vous que la connexion entre le moteur et le contrôleur est fiable, puis rebranchez l'alimentation.</p>
<p>Protection contre les surcharges E20</p>	<p>Si cette alarme se déclenche lors d'une montée, des objets lourds sur le bureau doivent être déplacés avant de relancer; si cette alarme se déclenche lors d'une descente, coupez l'alimentation, retirez certains objets lourds sur la table, puis rallumez.</p>
<p>Protection contre la sous-tension E31</p>	<p>En cas de panne de courant, vérifiez et assurez-vous que la connexion entre l'alimentation et le contrôleur est correcte, puis rallumez.</p>
<p>Protection contre la surtension E32</p>	<p>En cas de panne de courant, vérifiez et assurez-vous que la connexion entre l'alimentation et le contrôleur est correcte, puis rallumez.</p>

Solleva il desktop	Premi e tieni premuto il tasto "▲" per sollevare il desktop, e il tavolo smetterà di muoversi quando il tasto viene rilasciato una volta che la superficie raggiunge l'altezza adatta, o si fermerà automaticamente quando raggiunge la posizione più alta.
Abbassa il desktop	Premi e tieni premuto il tasto "▼" per abbassare il desktop, e il tavolo smetterà di muoversi quando il tasto viene rilasciato una volta che la superficie raggiunge l'altezza adatta, o si fermerà automaticamente quando raggiunge la posizione più bassa
Salva l'impostazione dell'altezza attuale	Dopo aver regolato l'altezza della scrivania regolabile all'altezza desiderata, tieni premuto il pulsante numerico ① o ② per più di due secondi finché non lampeggia H1 o H2. Questa altezza verrà memorizzata sul pulsante ① o ②.
Altezza memorizzata	Nell'interfaccia di visualizzazione dell'altezza, premi brevemente i tasti ① o ② e rilasciali, il tavolo in piedi si muoverà automaticamente all'altezza memorizzata precedentemente impostata per questa chiave.
Risparmio energetico	Se non ci sono operazioni di tastiera per molto tempo, il tubo digitale si spegnerà automaticamente. In questo momento, premi qualsiasi tasto per accendere il tubo digitale.

Menù di impostazione

<p>Impostazione protezione anti-collisione:</p> <p>Sul pannello di controllo, premere e tenere premuti contemporaneamente i tasti ① e ② per due secondi. Il livello di forza attuale che attiva la protezione anti-collisione lampeggerà e, dopo tre secondi, verrà visualizzata l'altezza attuale. Durante il periodo di lampeggio, premere qualsiasi tasto mostrerà l'altezza attuale.</p> <p>Se è necessario regolare il prossimo valore di forza target, ripetere semplicemente l'operazione sopra descritta. Ci sono 4 livelli di forza e il ciclo di regolazione è il seguente: Off (spento), H (pesante), N (normale), L (leggero).</p>
<p>Ripristina le impostazioni di fabbrica:</p> <p>Nei casi in cui lo stato di allarme "E10, E20" è attivo o dopo essere scesi alla posizione più bassa, premi a lungo il tasto "▼" per 3 secondi, quindi rilascialo quando viene visualizzato "rE5". Il tavolo in piedi scenderà alla posizione più bassa e rimbalzerà a una certa altezza, l'altezza più bassa verrà visualizzata sullo schermo una volta completato il ripristino. Si prega di notare che è necessario un reset del corso quando l'alimentazione è spenta per la prima volta.</p>

Protezione e allarme

<p>Protezione anticollisione E02</p>	<p>Durante il processo di sollevamento, se la scrivania vibra, urta un ostacolo o si inclina, il sistema attiverà un allarme e si sposterà immediatamente nella direzione opposta per una distanza preimpostata prima di annullare automaticamente l'allarme.</p> <p>L'allarme può anche essere annullato manualmente premendo un qualsiasi tasto durante il movimento inverso.</p> <p>Prima di riprendere il funzionamento, verificare e assicurarsi che la scrivania non subisca vibrazioni eccessive, non urti ostacoli e non si inclini.</p>
<p>Protezione da surriscaldamento Hot</p>	<p>Protezione dal surriscaldamento: Un funzionamento prolungato potrebbe attivare la protezione dal surriscaldamento. In tal caso, è necessario scollegare l'alimentazione elettrica e il controller, quindi ricollegarli, oppure attendere 15 minuti prima di poterlo utilizzare nuovamente.</p>
<p>Protezione dall'anomalia del motore E10</p>	<p>Scollegare l'alimentazione, ricontrollare e assicurarsi che la connessione tra il motore e il controller sia affidabile, quindi ricollegare l'alimentazione.</p>
<p>Protezione da sovraccarico E20</p>	<p>Se questo allarme si verifica durante la salita, spostare gli oggetti pesanti sul desktop prima di eseguire nuovamente; se questo allarme si verifica durante la discesa, interrompere l'alimentazione, rimuovere alcuni oggetti pesanti sul tavolo e quindi riaccendere.</p>
<p>Protezione da bassa tensione E31</p>	<p>In caso di interruzione di corrente, controllare e assicurarsi che la connessione tra l'alimentazione e il controller sia corretta, quindi riaccendere.</p>
<p>Protezione da sovratensione E32</p>	<p>In caso di interruzione di corrente, controllare e assicurarsi che la connessione tra l'alimentazione e il controller sia corretta, quindi riaccendere.</p>

Elevar el escritorio	Presione y mantenga presionada la tecla "▲" para elevar el escritorio, y la mesa se detendrá cuando se suelte la tecla una vez que la superficie alcance la altura adecuada, o se detendrá automáticamente cuando alcance la posición más alta.
Bajar el escritorio	Presione y mantenga presionada la tecla "▼" para bajar el escritorio, y la mesa se detendrá cuando se suelte la tecla una vez que la superficie alcance la altura adecuada, o se detendrá automáticamente cuando alcance la posición más baja.
Guardar la configuración de altura actual	Después de ajustar el escritorio regulable en altura a la posición deseada, mantén presionado el botón numérico ① o ② durante más de dos segundos hasta que H1 o H2 parpadee. Esta altura se memorizará en el botón ① o ②.
Altura de memoria	En la interfaz de visualización de altura, presione brevemente las teclas ① o ② y luego suéltelas, la mesa en posición de pie se moverá automáticamente a la altura de memoria previamente configurada para esta tecla.
Ahorro de energía	Si no hay operación de tecla durante mucho tiempo, el tubo digital se apagará automáticamente. En este momento, presione cualquier tecla para encender el tubo digital.

Menú de configuración

<p>Configuración de protección contra colisiones:</p> <p>En el panel de control, mantenga presionadas ambas teclas ① y ② durante dos segundos. El nivel de fuerza actual que activa la protección contra colisiones parpadeará, y después de tres segundos, se mostrará la altura actual. Durante el período de parpadeo, presionar cualquier tecla mostrará la altura actual.</p> <p>Si necesita ajustar el siguiente valor de fuerza objetivo, simplemente repita la operación anterior. Hay 4 niveles de fuerza, y el ciclo de ajuste es el siguiente: Off (apagado), H (pesado), N (normal), L (ligero).</p>
<p>Restaurar los ajustes de fábrica:</p> <p>En los casos en que el estado de alarma "E10, E20" está activado o después de llegar a la posición más baja, mantenga presionada la tecla "▼" durante 3 segundos, luego suelte cuando se muestre "rE5". El escritorio se moverá hacia abajo hasta la posición más baja y rebotará a cierta altura, la altura más baja se mostrará en la pantalla una vez que se complete el restablecimiento. Tenga en cuenta que se requiere un restablecimiento del recorrido cuando la alimentación está apagada por primera vez.</p>

Protección y Alarma

<p>Anti Kollisionsschutz E02</p>	<p>Durante el proceso de elevación, si el escritorio vibra, choca o se inclina, el sistema activará una alarma y se moverá inmediatamente en la dirección opuesta por una distancia preestablecida antes de cancelar automáticamente la alarma.</p> <p>La alarma también se puede cancelar manualmente presionando cualquier tecla durante el movimiento inverso.</p> <p>Antes de reanudar la operación, verifique y asegúrese de que el escritorio no experimente vibraciones excesivas, no choque con obstáculos ni se incline.</p>
<p>überhitzen-Schützen Hot</p>	<p>Protección contra sobrecalentamiento: El funcionamiento prolongado puede activar la protección contra sobrecalentamiento. En tal caso, debe desconectar la alimentación eléctrica y el controlador, luego volver a conectarlos, o esperar 15 minutos antes de poder usarlo nuevamente.</p>
<p>Schutz vor Motoranomalien E10</p>	<p>Desconecte la alimentación, verifique nuevamente y asegúrese de que la conexión entre el motor y el controlador sea confiable, luego vuelva a conectar la alimentación.</p>
<p>Überlast-Schützen E20</p>	<p>Si esta alarma ocurre al subir, los objetos pesados en el escritorio deben moverse antes de volver a funcionar; si esta alarma ocurre al bajar, corte la alimentación, retire algunos objetos pesados de la mesa y luego vuelva a encenderla.</p>
<p>Schutz vor Unterspannung E31</p>	<p>En caso de fallo de alimentación, revise y asegúrese de que la conexión entre la fuente de alimentación y el controlador sea correcta, y luego vuelva a encenderla.</p>
<p>Schutz vor Überspannung E32</p>	<p>En caso de fallo de alimentación, revise y asegúrese de que la conexión entre la fuente de alimentación y el controlador sea correcta, y luego vuelva a encenderla.</p>

36010350
A/O BH