











Assembly Instructions

Caution : You must read this before you proceed

Care & Maintenance

- ⊘  ● Not for commercial use. For residential use only.
- ⊘  ● Prolonged exposure to rain may cause rusting which can stain floors.
- ⊘  ● Do not put hot items directly on furniture surface.
- ⊘  ● Do not clean furniture with harsh cleansers or polish.
- ✓  ● To obtain the longest lifespan of your outdoor products, minimizing exposure to direct sunlight is recommended.
- ⊘  ● Children should not climb or jump on the furniture.
- ⊘  ● Do not write on furniture without a padded barrier to protect the surface.
- ✓  ● To obtain the longest lifespan of your outdoor products, avoid extended and lengthy exposure to rain, snow, and direct sunshine. Whenever possible cover the product and /or place under patio or awnings.
- ⊘  ● Stains may be removed with mild soap solution and damp cloth.
- ✓  ● Keep away from sources of ignition.
- ✓  ● Dust and pick-up spills using a clean, non-colored, lint-free cloth.

Please look into the Seat Panel for hardware packs

TABLE

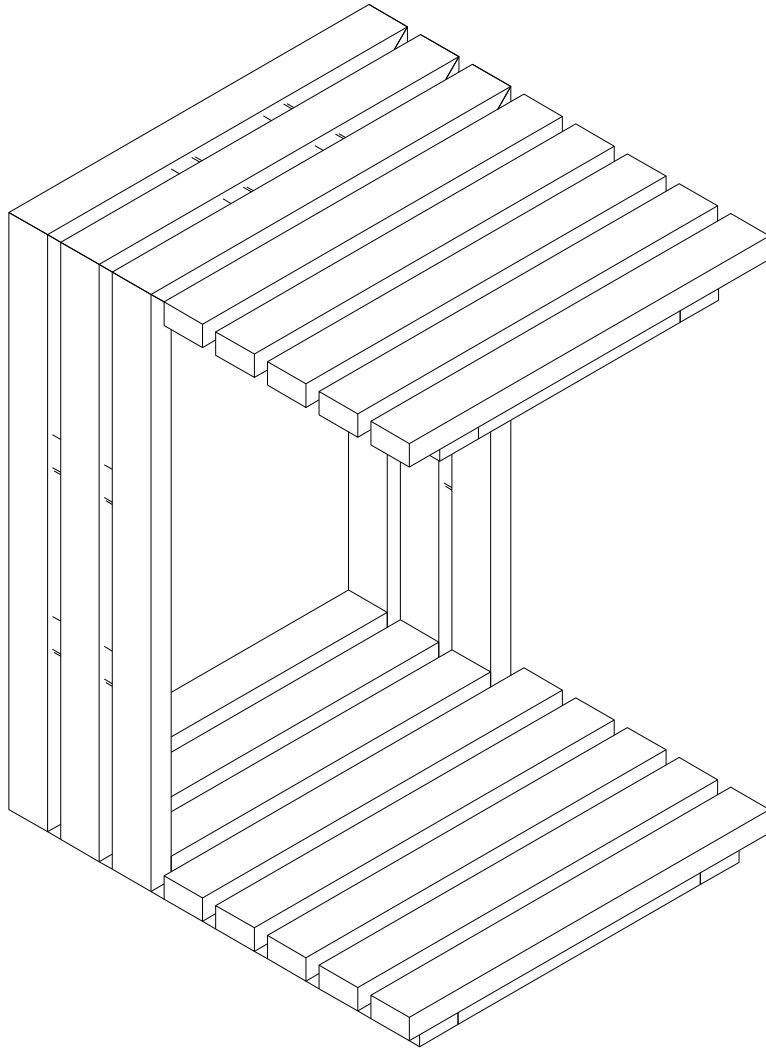

Caution: This Table is NOT a TOY.



Keep your child/children at bay during the assembly process.

For turning the Table and to prevent damage to the Table, 02 persons may be needed to execute this action.

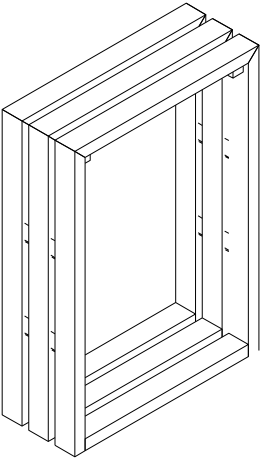
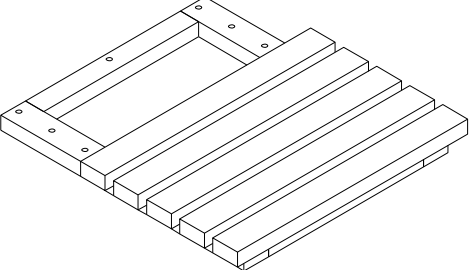
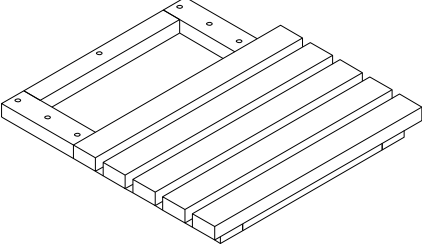
Parts List

Label	Picture	Description	QTY
F		Table Leg Panel	1
G		Table Top	1
H		Table Bottom	1

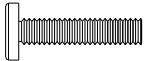
Hardware List

Label	Picture	Description	QTY
②		Bolt (M6x35)	15
③		Allen Wrench (M4)	1

Assembly Preparation

Before Beginning Assembly

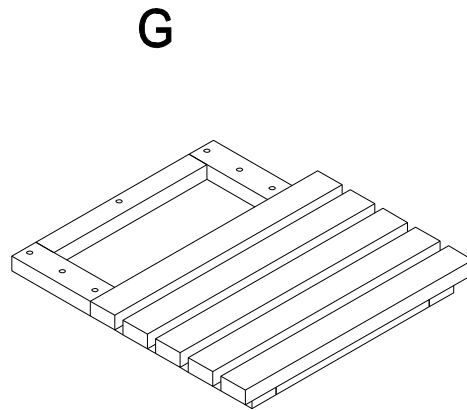
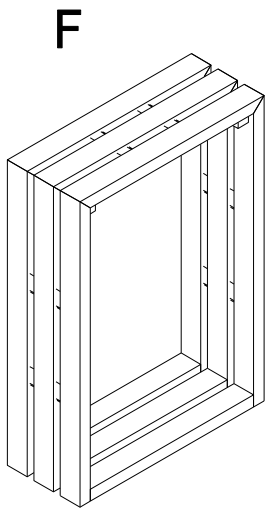

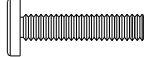
②  X15

③  X1

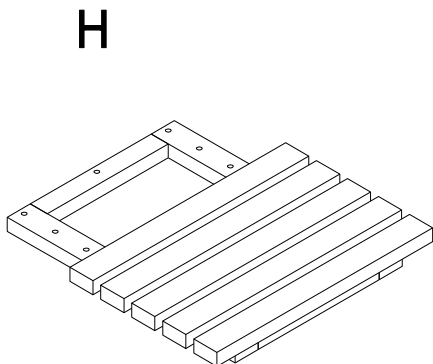



- Read instructions, cover to cover.



- Have 2 adults on hand for assembly.



- Do not assemble on flooring or carpet.



- Assemble on a clean non-marring surface (packing foam).



- Save all packaging until finished.

Assembly Preparation

Overview

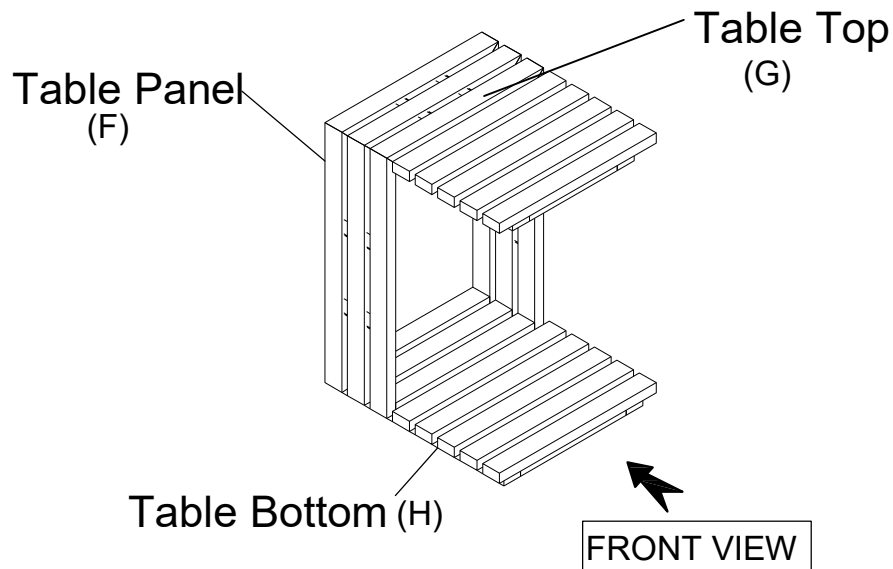

This Table has multiple parts and may require up to some 30 minutes to assemble. To give you an overview of the Table, the above picture is to help you put the various parts into perspective. Please read through the instructions here below to familiarise the parts and steps before assembly.

Step 1

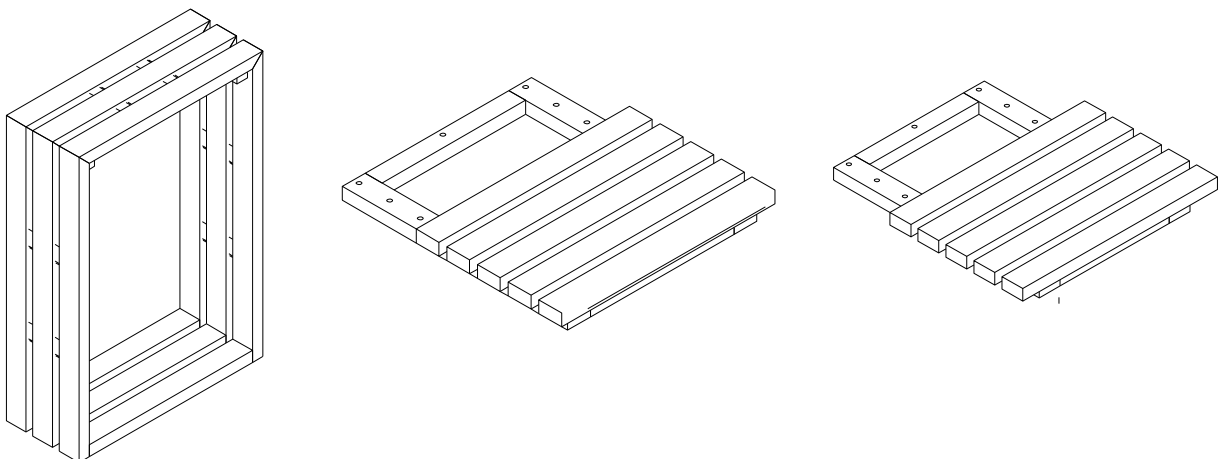

Unpack and place all parts on a clean, non-marring surface

Step 2

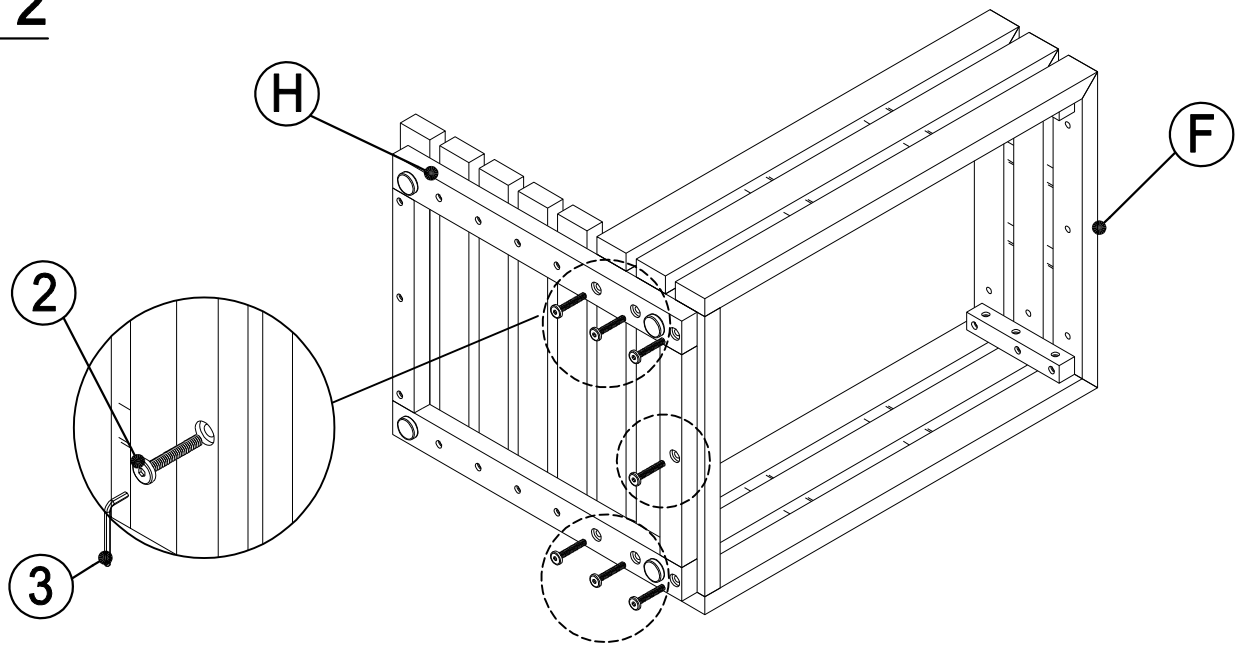

With assistance from your adult partner, place the Table Leg Panel (F) onto a clean, non marring surface, attach the Table Bottom (H) to Table Leg Panel (F) by using Bolts (2), with Allen Wrench (3) as shown above.
DO NOT fully tighten the Bolts.

Step 3

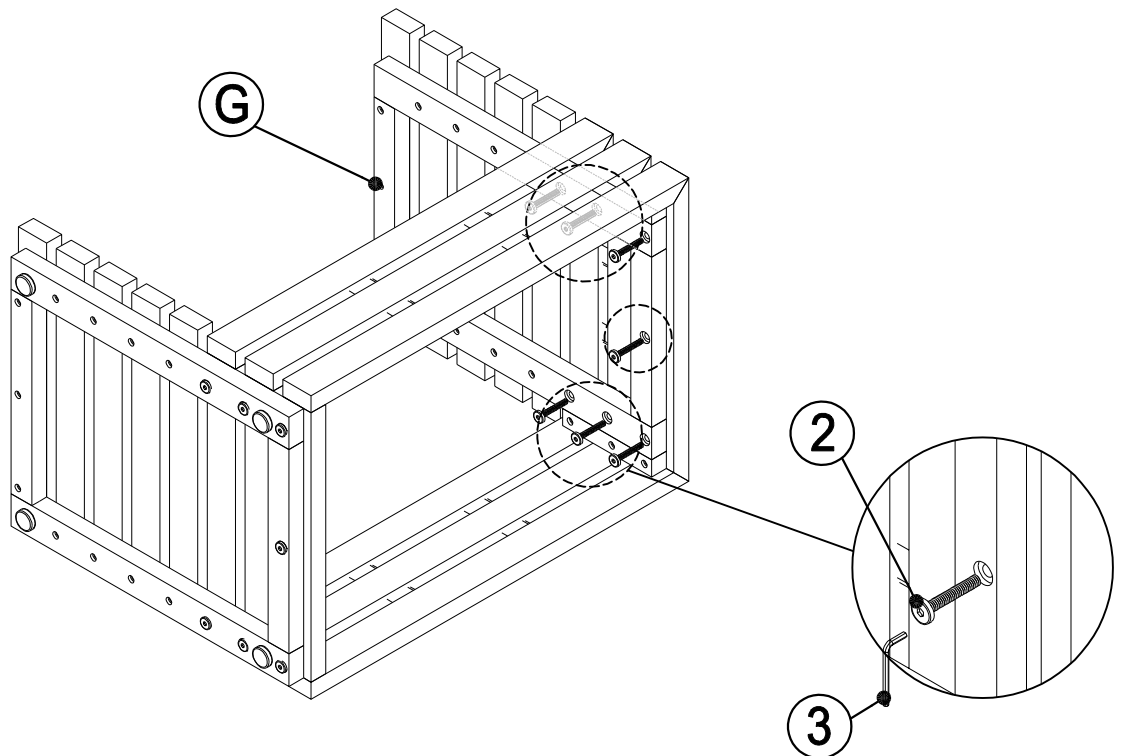

With assistance from your adult partner, place the Table Leg Panel (F) onto a clean, non marring surface, attach the Table Top (G) by using Bolts (2), with Allen Wrench (3) as shown above.
DO NOT fully tighten the Bolts.

Step 4

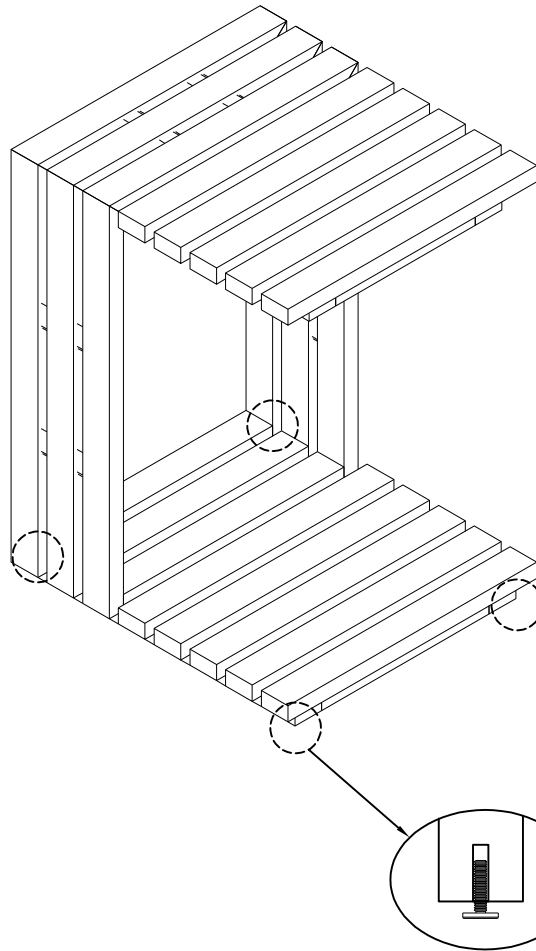

Twist and Adjust height for balance Adjust low for balance
Adjust Pre-installed Levellers height for balance

With assistance from your adult partners, turn the Table right side up normal flat ground.

Place the Bench on a LEVEL surface.

Inspect it and make sure all parts are adequately connected.

Gently and gracefully, sit onto the Table. This pressure will help to align all the parts at all joint areas.

Check for wobbles on a LEVEL surface. If no wobbles are found, proceed to tighten the Bolts in a sequential manner, until evenly secured.

Adjust the Levelers until the Bench is level with the ground.

To adjust the Levelers, get assistance from an adult partner to lift/lean and hold the Table while you are working.