

## Parts and Damage Replacement Procedure

1. Please inspect your purchase immediately.
2. This procedure covers product purchased from an authorized Reseller and was received in its originally sealed carton.
3. If you find a part missing or damaged, you have a 30-day window in which to order a replacement part from the date on your purchase receipt.
4. You have 3 ways to do this. You will need a copy of your purchase receipt.
  - a. By Fax: Fax the parts order form below and along with your receipt to
  - b. By Email: Email the order form and along with your receipt to:
  - c. By Mail: Fill out the parts order form below and along with a copy of your receipt send it to

shipped within 7-10 business days.

**A COPY OF YOUR PURCHASE RECEIPT OR INVOICE MUST BE ATTACHED TO THIS ORDER FORM.  
NO ORDERS WILL BE PROCESSED WITHOUT PROOF OF PURCHASE.**

NAME: \_\_\_\_\_  
ADDRESS: \_\_\_\_\_ (No Post Office Boxes)  
CITY: \_\_\_\_\_ STATE: \_\_\_\_\_ ZIP: \_\_\_\_\_  
PHONE: \_\_\_\_\_ FAX: \_\_\_\_\_  
EMAIL: \_\_\_\_\_

### REASON FOR REPLACEMENT/PLEASE CHECK APPROPRIATE BOX.

- ( ) Damaged /scratched, cracked, broken, crushed, etc.
- ( ) Mechanical malfunction/ drawer glides, swivel mechanisms, lid stays, etc.
- ( ) Missing pieces
- ( ) Unfinished surface
- ( ) Wrong color
- ( ) Other

IF MORE THAN ONE MODEL NUMBER IS LISTED ABOVE, PLEASE SPECIFY THE EXACT MODEL NUMBER OF YOUR ITEM IN THE SPACE PROVIDED BELOW.

Model Number	Part Letter Code	Quantity

# ASSEMBLY INSTRUCTIONS

## ASSEMBLY TIPS :





1. Remove hardware from box and sort by size
2. Please check to see that all hardware and parts are present prior to start of assembly.
3. Please follow attached instruction in the same sequence as numbered to assure fast & easy assembly.





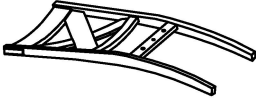

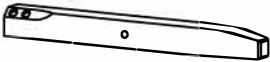

### Warning !

1. Don't attempt to repair or modify parts that are broken or defective. Please contact the store immediately.
2. This product is for home use only and not intended for commercial establishment

## PARTS IDENTIFICATION

A		CHAIR BACK	1 PC
B		CUSHION SEAT WITH FRAME	1 PC
C		LEFT FRONT LEG	1 PC
D		RIGHT FRONT LEG	1 PC
E		LEFT SIDE STRETCHER	1 PC
F		RIGHT SIDE STRETCHER	1 PC

## HARDWARE IDENTIFICATION

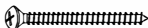
1		LONG BOLT	4 PCS
2		MEDIUM BOLT	2 PCS
3		SHORT BOLT	2 PCS
4		LOCK WASHER	8 PCS
5		FLAT WASHER	8 PCS
6		ALLEN WRENCH	1 PC
7		SCREW	4 PCS

**NOTE : QUANTITIES SHOWN ARE FOR ONE CHAIR**

## ASSEMBLY INSTRUCTIONS

### STEP 1

Align and fasten cushion seat with frame (B) to bottom rail of chair back (A) using short bolt (3), lock washer (4) and flat washer (5). DO NOT FULLY TIGHTEN AT THIS STEP.

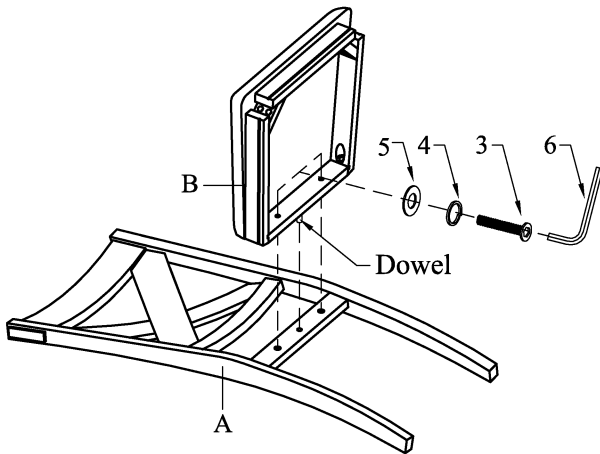

### STEP 2

Align and fasten cushion seat with frame (B) to chair back leg (A) using medium bolt (2), lock washer (4) and flat washer (5). THEN FULLY TIGHTEN ALL THE BOLTS AT STEP 1 AND 2 WITH ALLEN WRENCH (6).

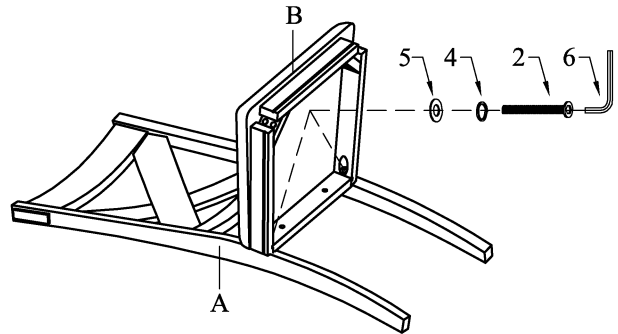

### STEP 3

3.1 Align and insert left (E) and right (F) side stretcher to chair back leg (A) and left (C) and right (D) front leg.  
3.2 Align and fasten left (C) and right (D) front leg to cushion seat with frame (B) using long bolt (1), lock washer (4) and flat washer (5) and fully tighten with Allen wrench (6).

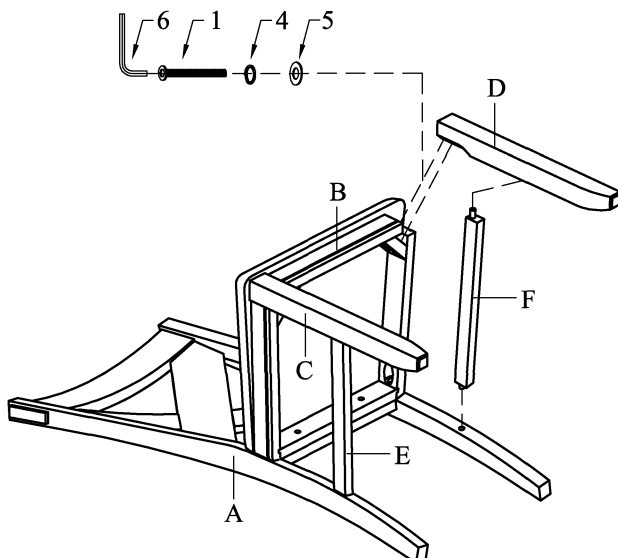

### STEP 4

Insert screw (7) into bottom of stretchers and fully tighten with screw driver (NOT INCLUDED).

