

# INSTALLATION GUIDE

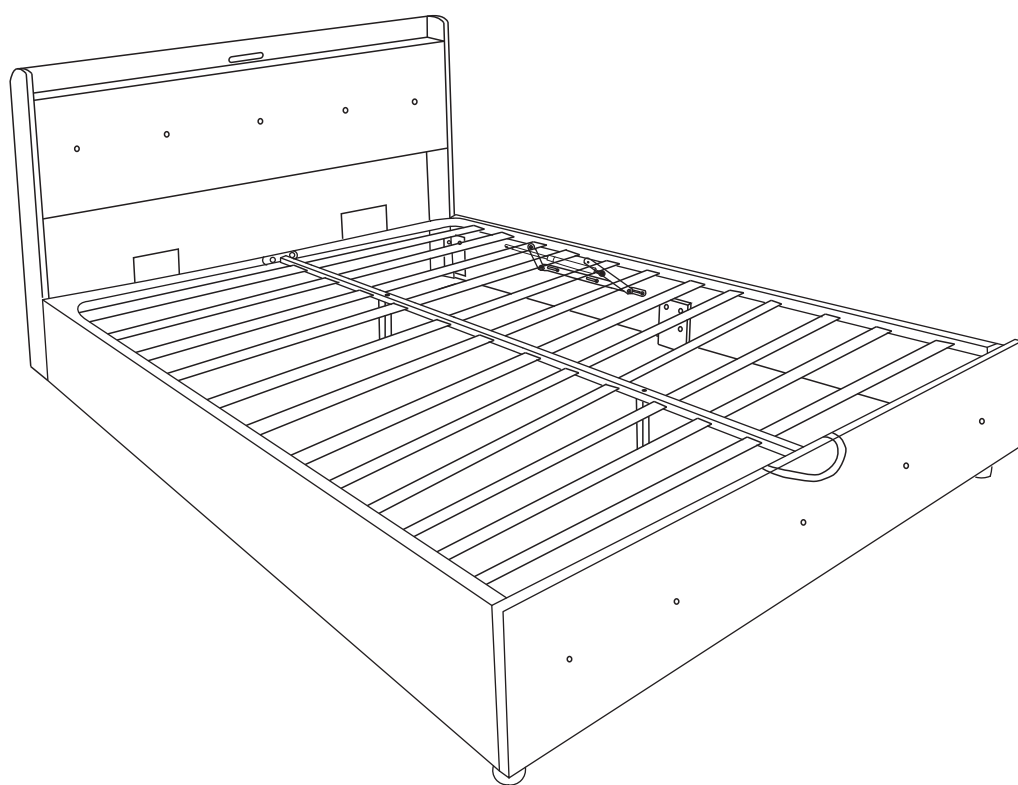





DEAR CUSTOMER,

Caution:

1. Please read all instructions before assembly and check the carton for any parts that may have come loose during shipment. It is recommended to use two or more persons during the assembly process.
2. Please do not discard any packaging before you have checked all the parts and fittings are included. If for any reason this product needs to be returned it must be returned packed in its original packaging.
3. Assemble this product on a flat and clean surface to avoid scratching.
4. The product set is delivered with 2 boxes.  
We recommend assembling the set after you receive all the boxes.

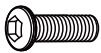
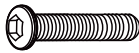
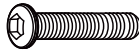

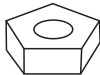
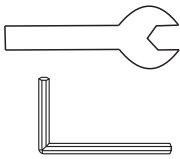



## HARDWARE LIST

N652P190384 All other components are inside 01 and need to be opened and removed

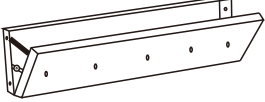



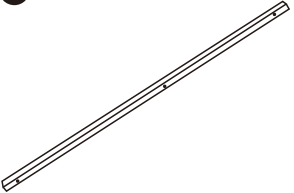

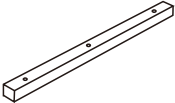
Ax22  <b>M6*20mm</b>	Bx3  <b>M6*25mm</b>	Dx22  <b>M6*35mm</b>	Ex12  <b>M6*45mm</b>
Fx5  <b>M6*55mm</b>	Gx32  Flat washer	Hx8  Nut	Ix1  Allen key
Jx2  Felt mat			

# SUBASSEMBLY

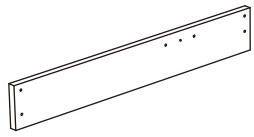
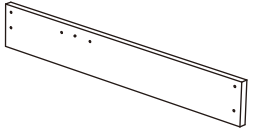
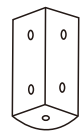
All other components are inside 01 and need to be opened and removed

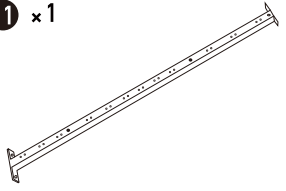

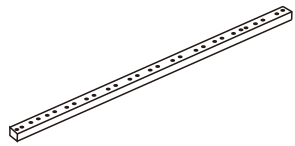
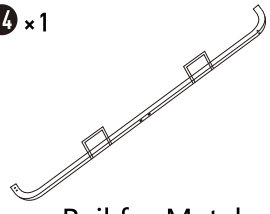
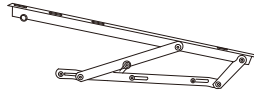
<p>01 x1</p>  <p>Headboard X1</p>	<p>02 x1</p>  <p>Head board leg X1</p>	<p>03 x1</p>  <p>Head board leg X1</p>	<p>07 x2</p>  <p>connecting board X2</p>
<p>10 x1</p>  <p>footboard bar X1</p>	<p>17 x 24</p>  <p>Slats X24</p>	<p>20 x2</p>  <p>middle leg X2</p>	<p>22 x2</p>  <p>said board bar X2</p>

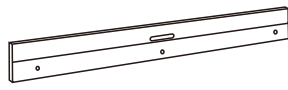
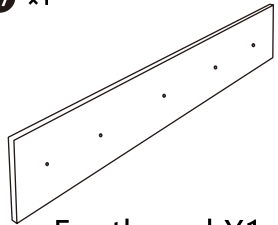
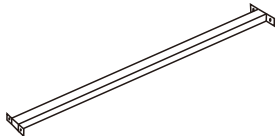
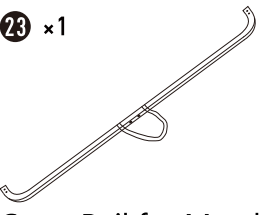
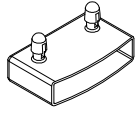
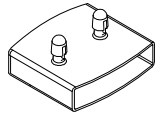
N652P190385

<p>04 x1</p>  <p>Side Rails(LH) X1</p>	<p>05 x1</p>  <p>Side Rails(RH) X1</p>	<p>08 x2</p>  <p>angle iron X2</p>	<p>09 x2</p>  <p>back leg X2</p>
<p>11 x1</p>  <p>Side Rails for Metal Slat Frame X1</p>	<p>12 x2</p>  <p>Centre Support Leg X2</p>	<p>13 x2</p>  <p>Side Rails for Metal Slat Frame X2</p>	<p>14 x1</p>  <p>Cross Rail for Metal Slat Frame - Footend X1</p>
<p>15 x2</p>  <p>Lift Mechanism X2</p>	<p>16 x2</p>  <p>Gas Strut X2</p>	<p>18 x1</p>  <p>Head board leg X1</p>	<p>19 x1</p>  <p>Footboard X1</p>
<p>21 x1</p>  <p>Reinforced Pipe X1</p>	<p>23 x1</p>  <p>Cross Rail for Metal Slat Frame - Footend X1</p>	<p>24 x24</p>  <p>Plastic Slat Caps X24</p>	<p>25 x12</p>  <p>Centre Slat Caps X12</p>

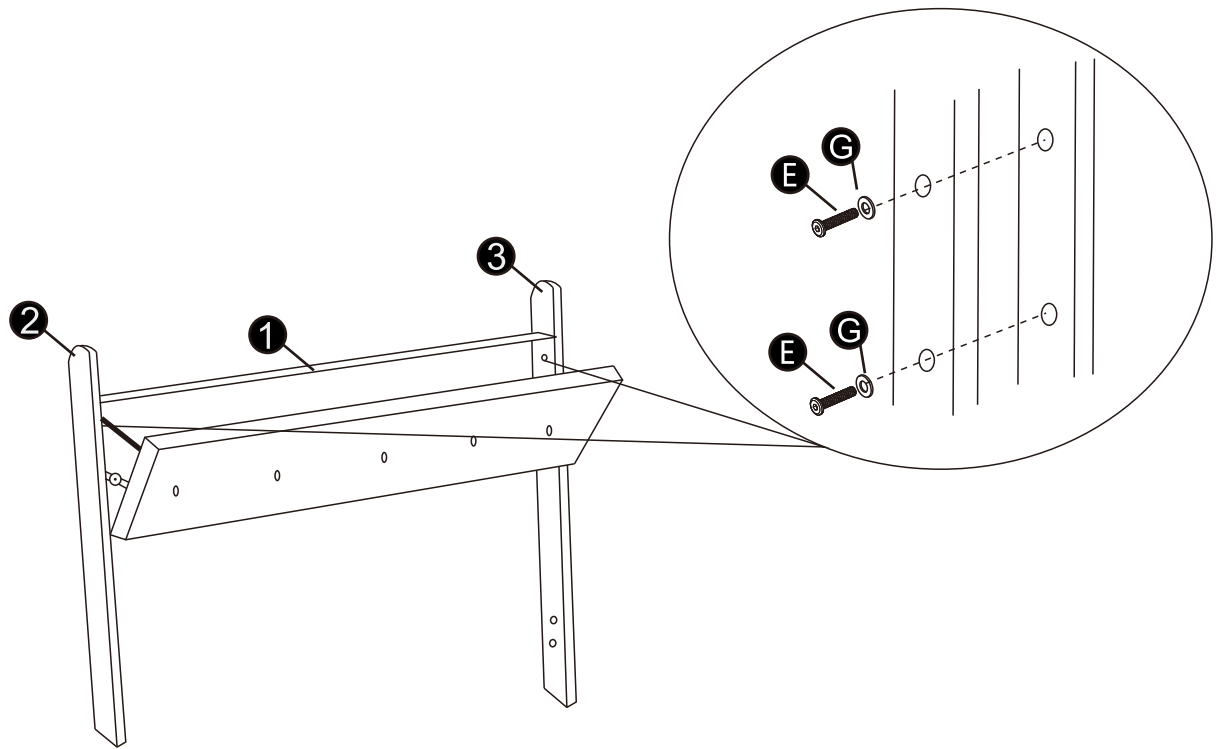

## Step 1

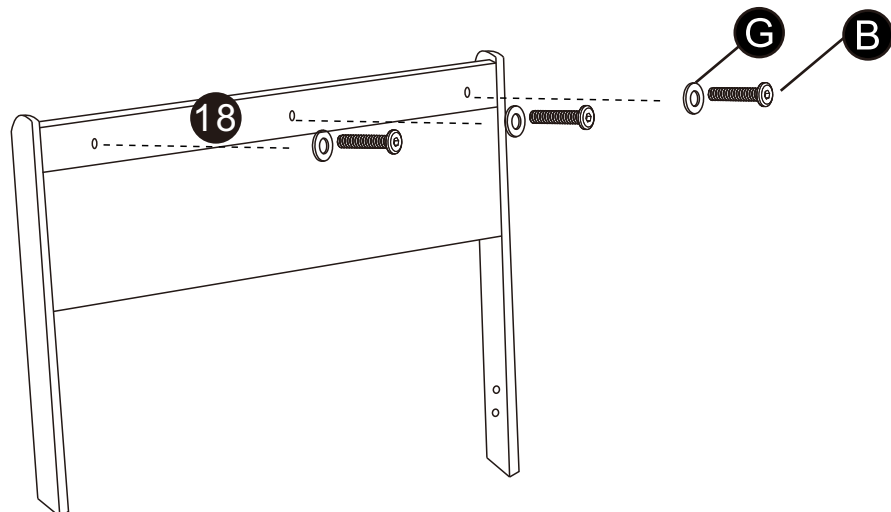

E		M6*45mm	4
G			4

## Step 2



B		M6*25mm	3
G			3

### Step 3

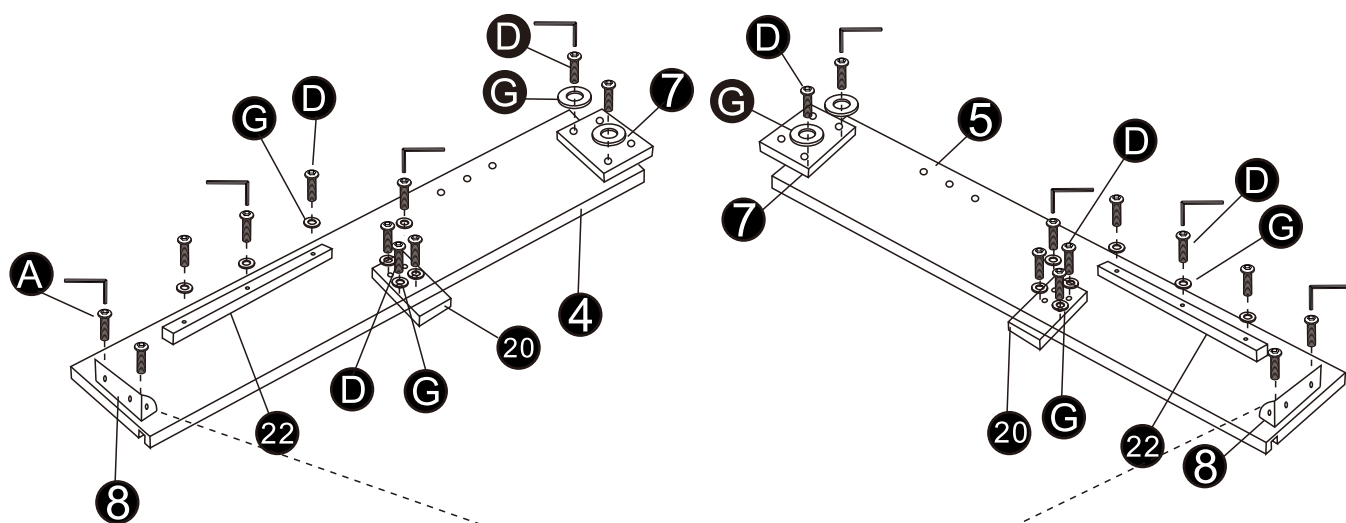

<b>A</b>	M6*20MM	<b>4</b>
<b>D</b>	M6*35mm	<b>18</b>
<b>G</b>		<b>18</b>

### Step 4

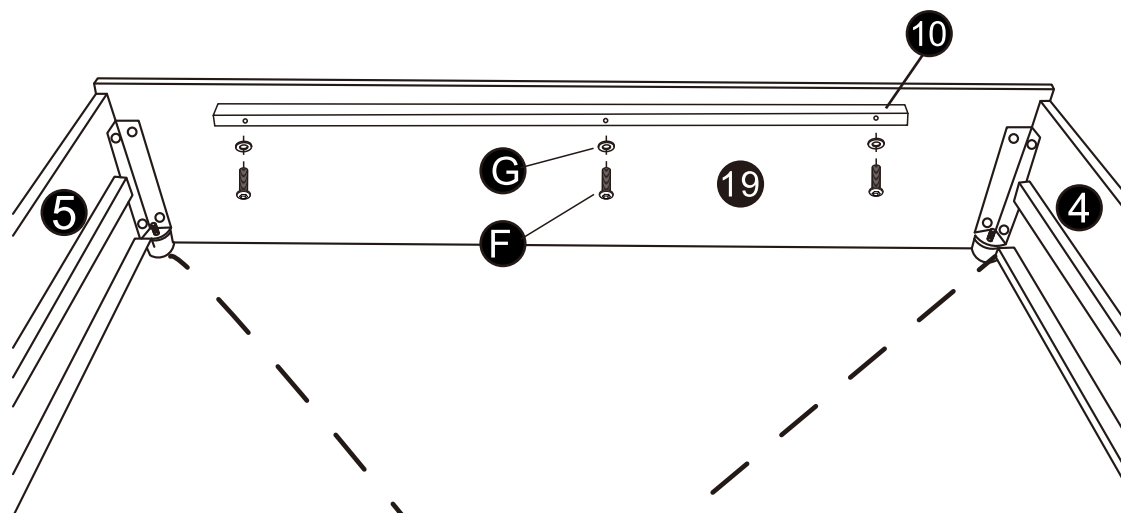

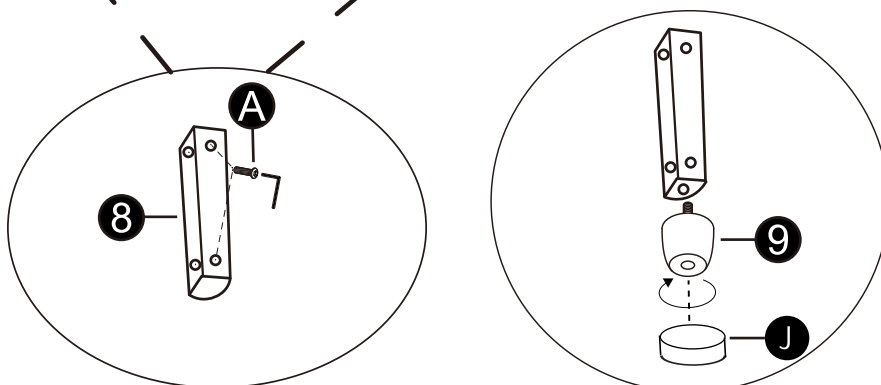

<b>A</b>	M6*20MM	<b>4</b>
<b>F</b>	M6*55mm	<b>3</b>
<b>G</b>		<b>3</b>



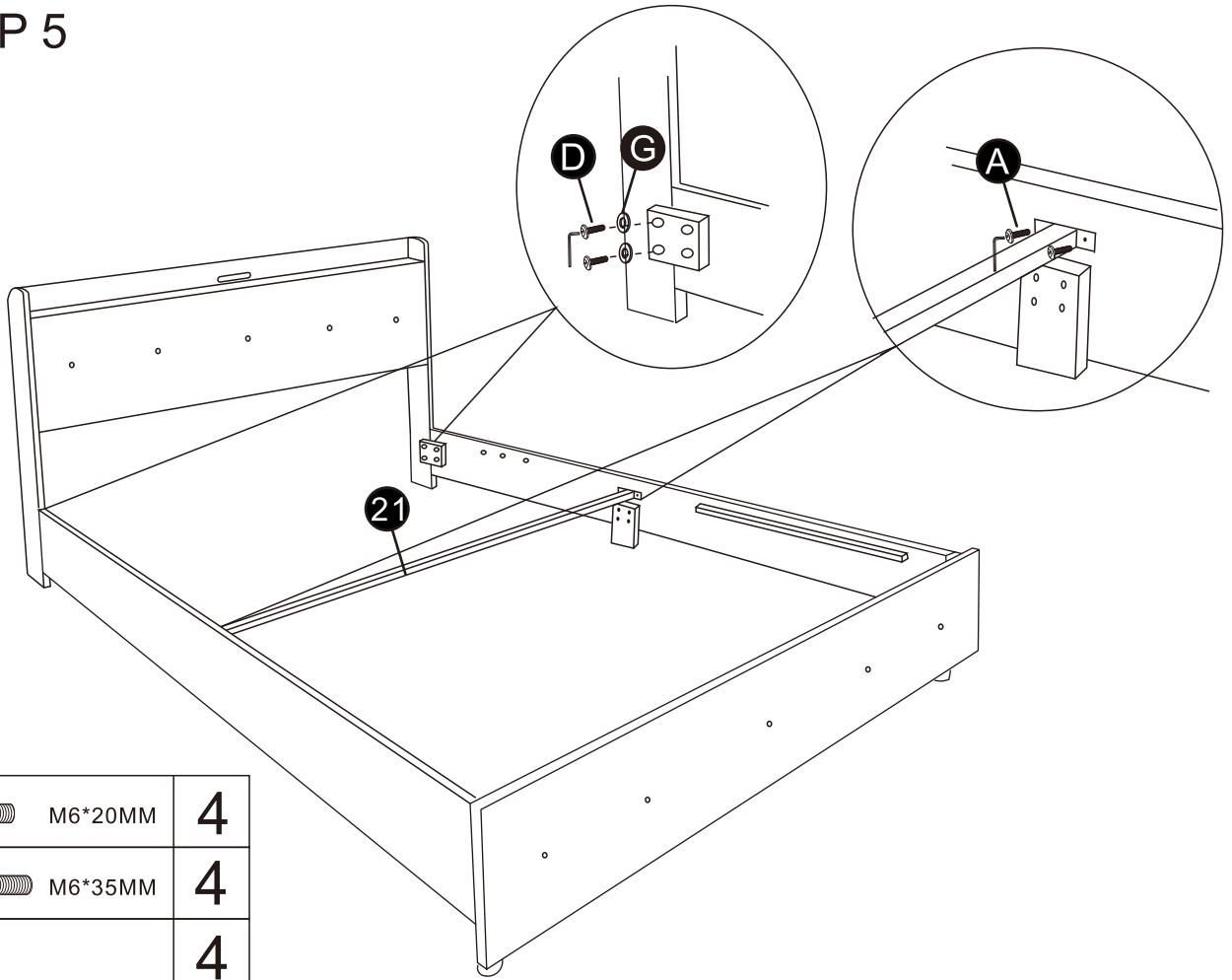

# STEP 5



A	 M6*20MM	4
D	 M6*35MM	4
G		4

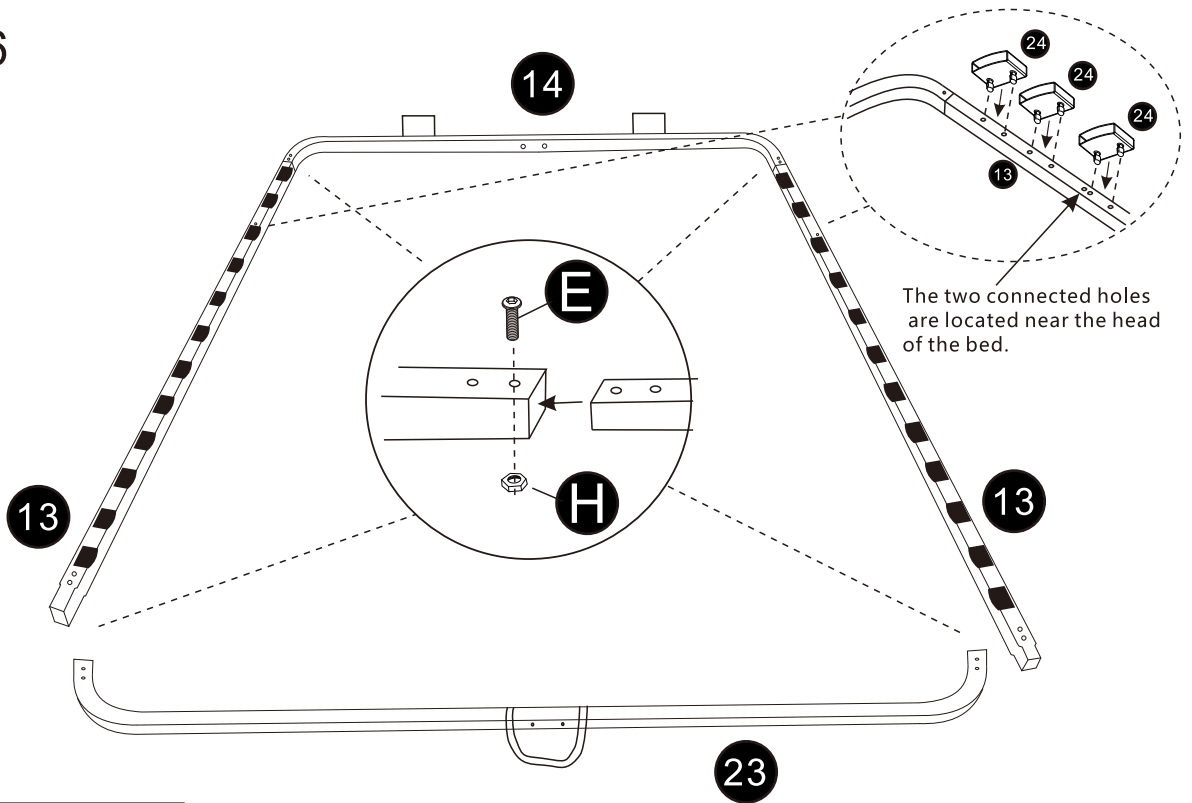

# STEP 6

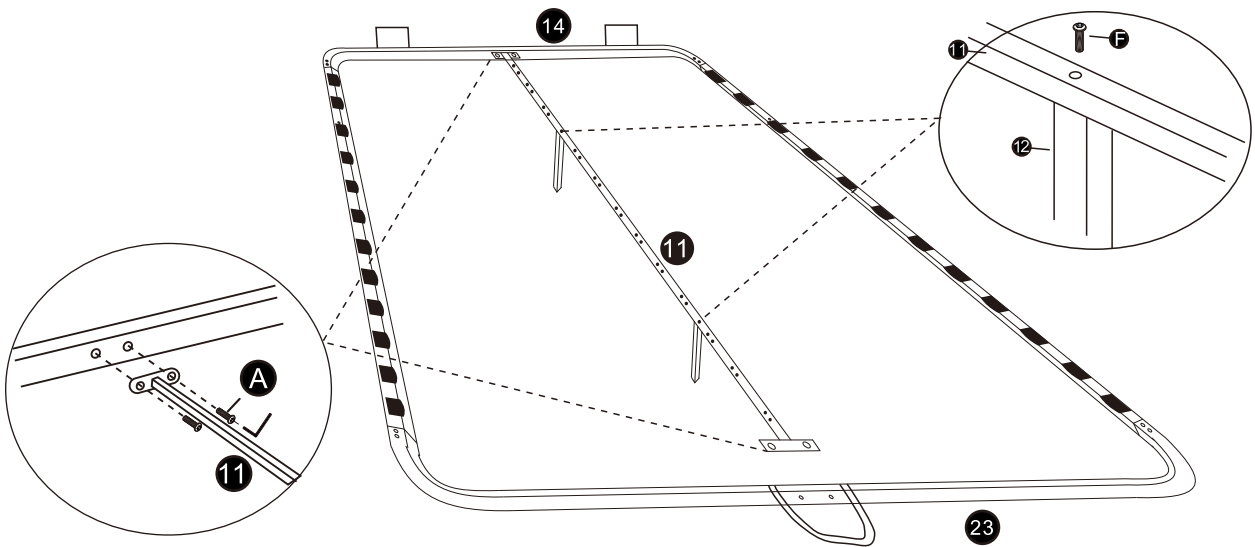

E	 M6*45mm	4
H	 M6	4

# STEP 7



A	 M6*20MM	4
F	 M6*55MM	2

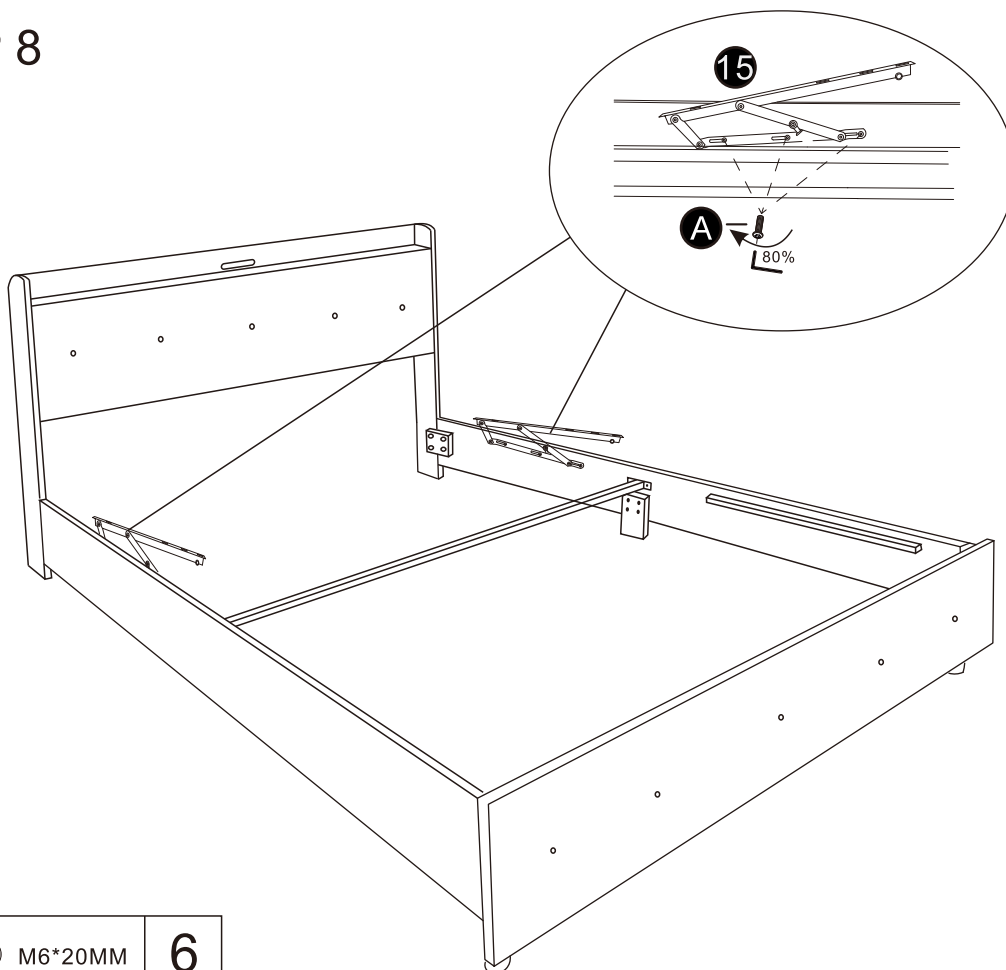

# STEP 8

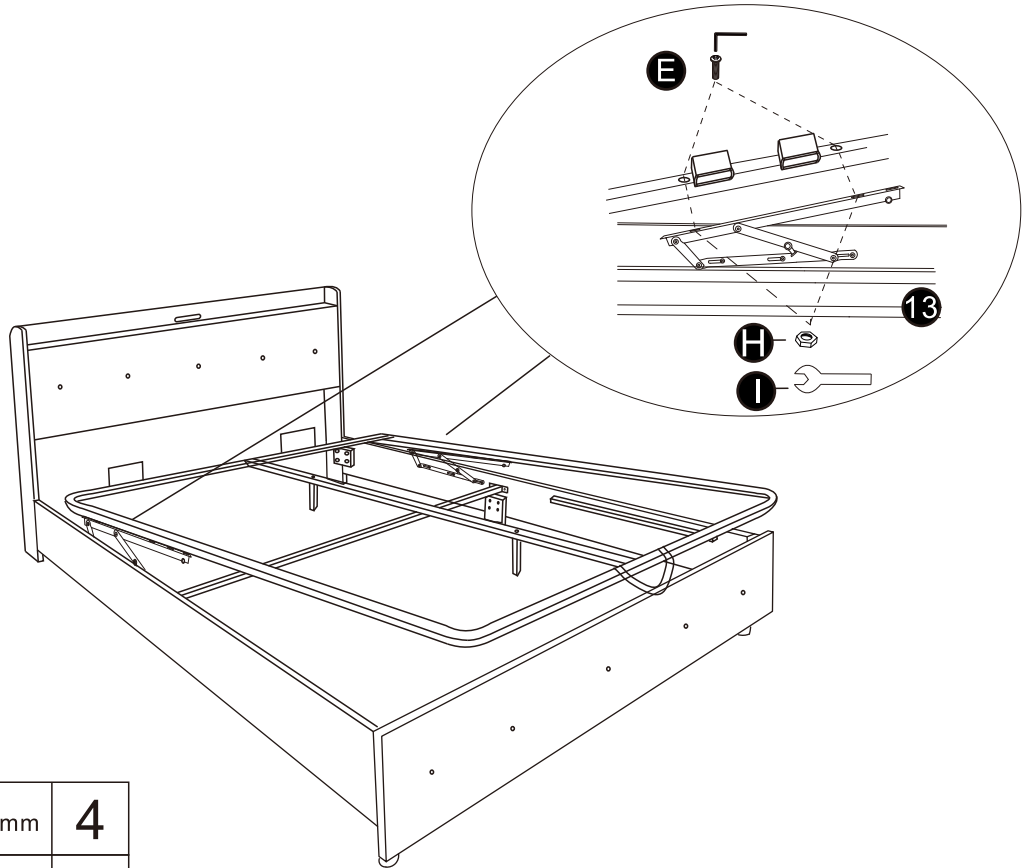

A	 M6*20MM	6
---	---	---

# STEP 9



E	 M6*45mm	4
H	 M6	4

# STEP 10

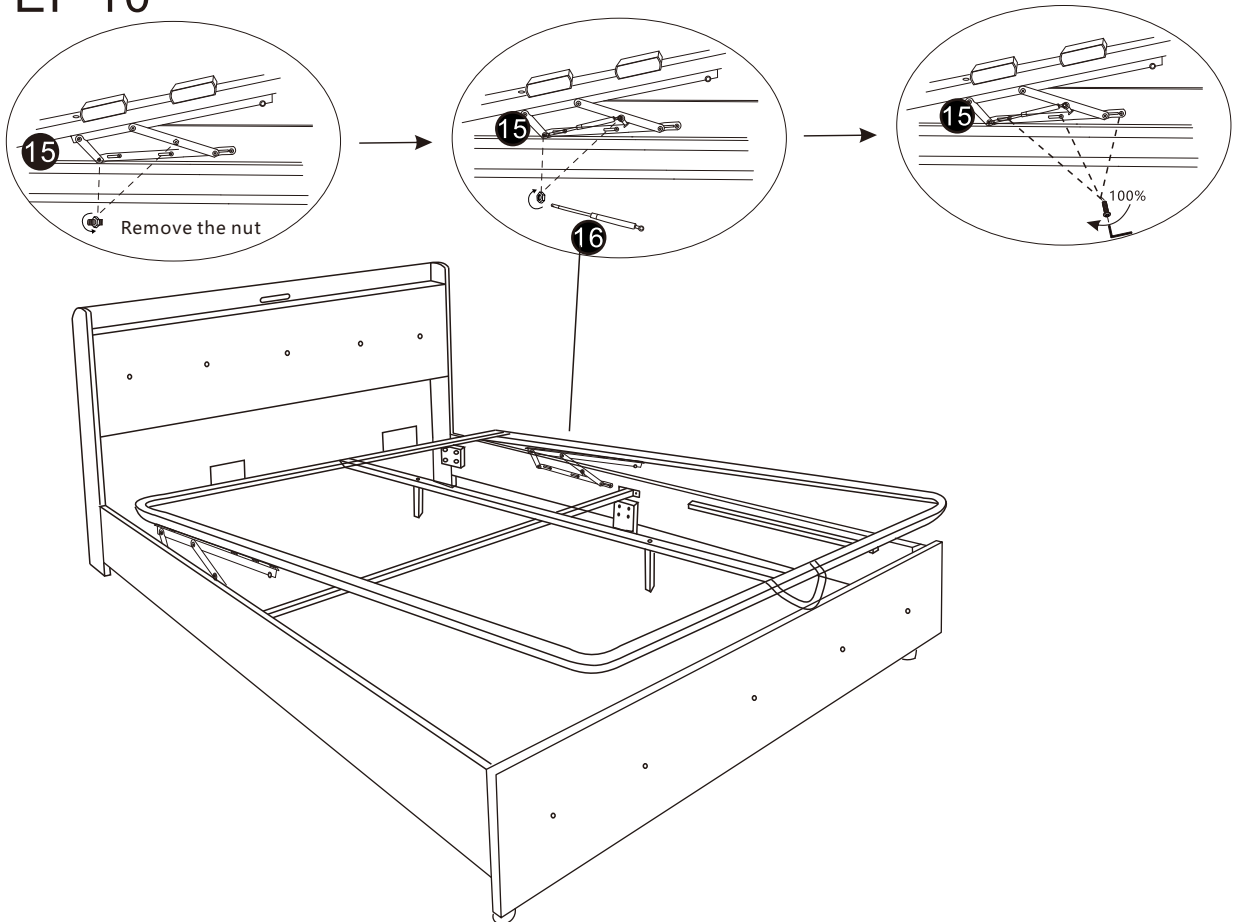

## STEP 11

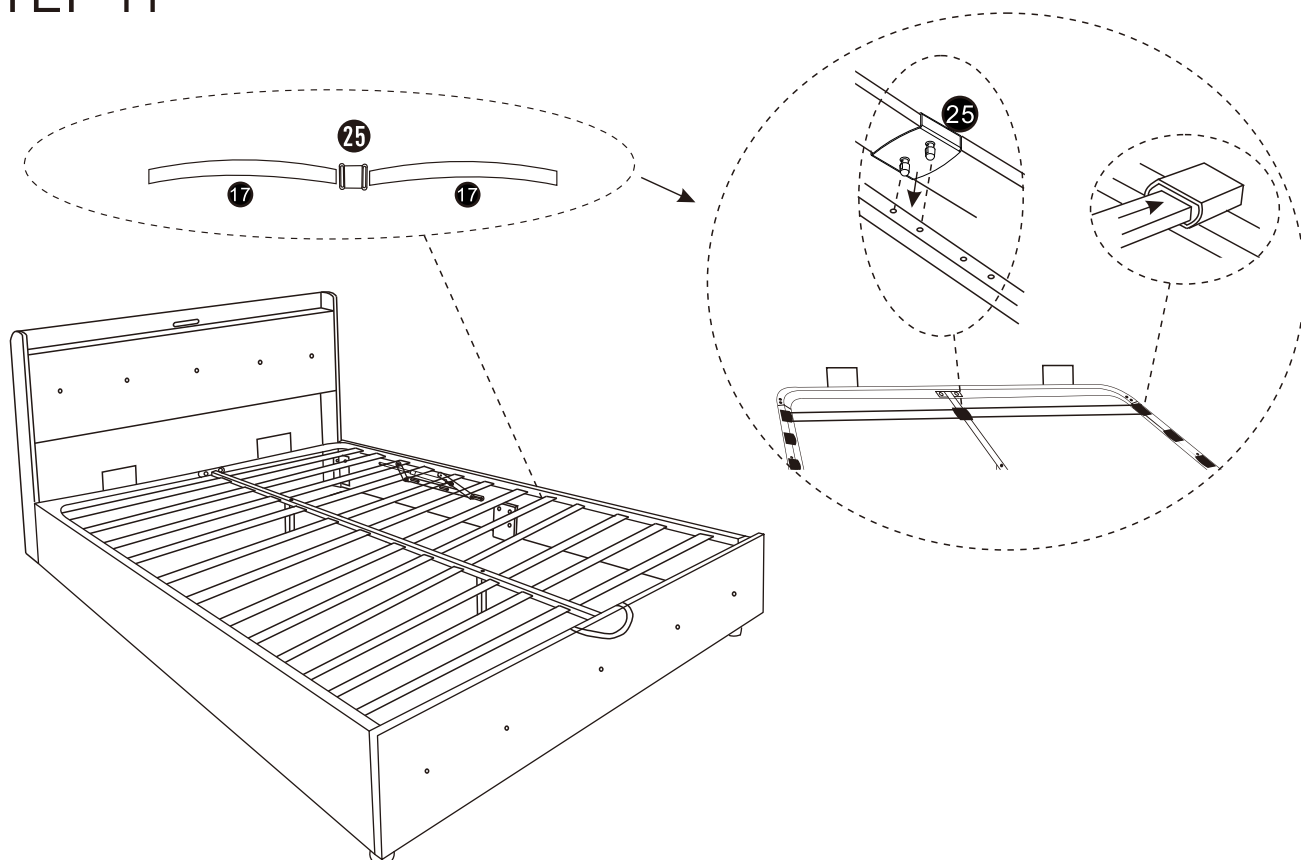

## STEP 12

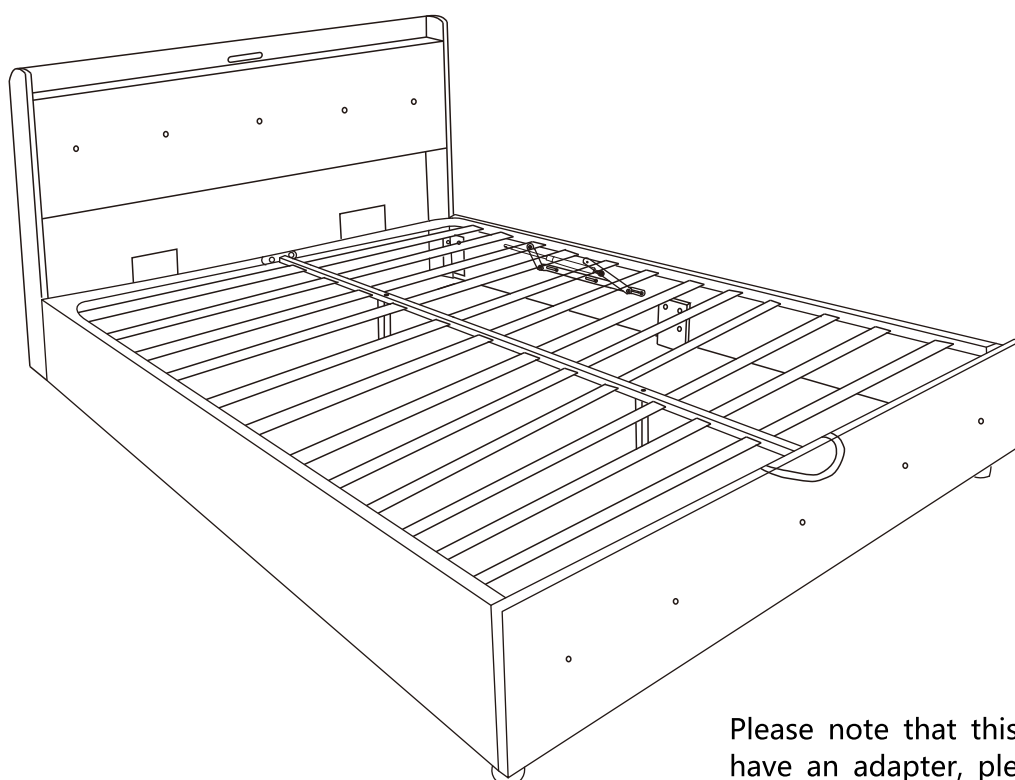

Please note that this product does not have an adapter, please prepare a USB power supply.

# Attestation of Compliance



**Attestation No.** : LCSA07113013E

**Approval Holder** : Anji Yichen Smart Home Technology Co. , Ltd.

**Address** : No. 28, No. 5 team, Xiaoyuan community, Xiaoyuan Street, Anji County, Huzhou, Zhejiang province, China

**Manufacturer** : Anji Yichen Smart Home Technology Co. , Ltd.

**Address** : No. 28, No. 5 team, Xiaoyuan community, Xiaoyuan Street, Anji County, Huzhou, Zhejiang province, China

**Brand Name** : N/A

**Product** : YC-Phantom RGB Light

**Type/Model Name** : YC-Phantom-17 Key Remote Control 60 Beads, YC-Phantom-17 Key Remote Control 30 Beads, YC-Phantom-14 Key Remote Control 60 Beads, YC-Phantom-14 Key Remote Control 30 Beads, YC-Phantom-21 Key Remote Control 60 Beads, YC-Phantom-21 Key Remote Control 30 Beads

**H/S Version** : HW: /  
SW: /

**Attestation of the technical design of the radio equipment according to the following essential requirements set out in article 3 of the RED 2014/53/EU:**

**Article 3.1a): Health and Safety** Conform

**Article 3.1b): Electromagnetic Compatibility** Conform

**Article 3.2: Effective Use of the Radio Spectrum** Conform

**CE-marking**

Marking Example (Class 1)



This attestation is issued in accordance with the Directive 2014/53/EU of the European Parliament and of the Council of 16 April 2014 on the harmonisation of the laws of the Member States relating to the making available on the market of radio equipment.



July 28, 2023

.....  
**Date of issue**

.....  
**Manager**

Shenzhen LCS Compliance Testing Laboratory Ltd.  
Room 101, 201, Building A and Room 301, Building C, Juji Industrial Park, Yabianxueziwei, Shajing Street, Bao'an District, Shenzhen, Guangdong, China  
Tel: (86)755-82591330 Fax: (86)755-82591332  
Http://www.LCS-cert.com Email: webmaster@LCS-cert.com

