

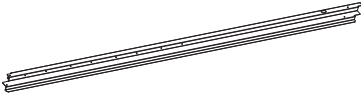





FOUNDATION

<p>BK1 X1</p> 	<p>BK1L X1</p> 	
<p>BK2 X1</p> 	<p>BK2R X1</p> 	
<p>BE4 X2</p> 	<p>BE4R X2</p> 	<p>BE4L X2</p> 

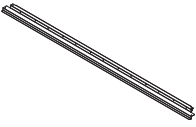
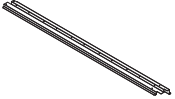
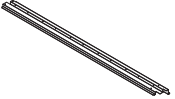
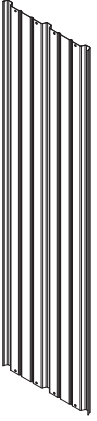
PLATES

<p>W1A X25</p> 	<p>WS2A X4</p> 	<p>W3A X2</p> 	<p>WS3A X3</p> 
<p>PK1 X2</p> 	<p>PK2 X2</p> 		
<p>PK3S X4</p> 	<p>PK4 X14</p> 		

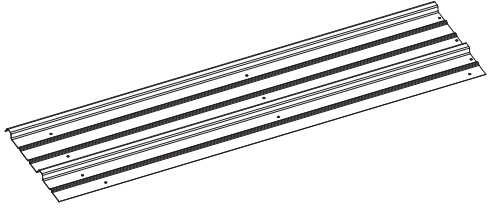
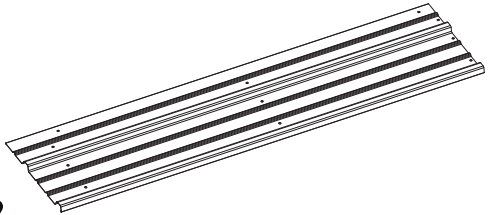
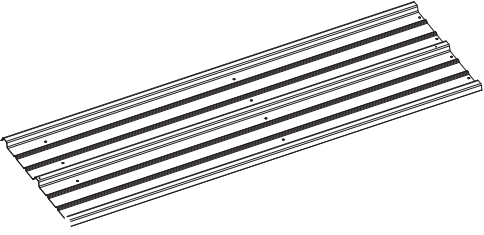
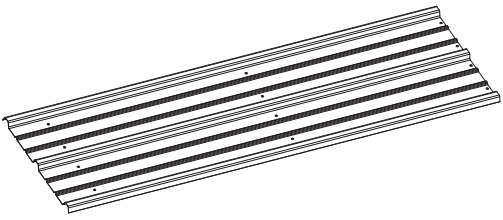
S

PLATES

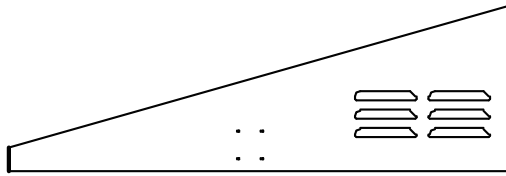

A5 X2

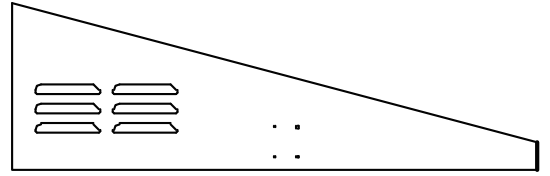

A6 X2

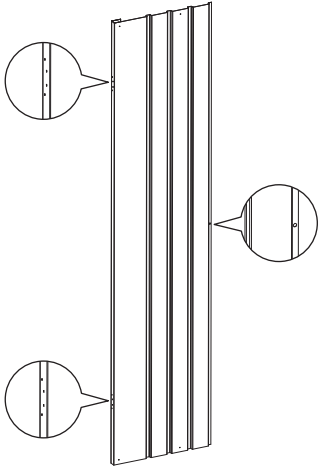

DLA X1

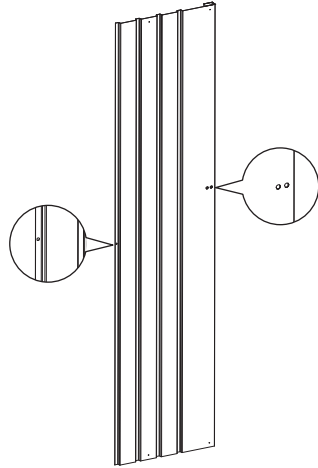

DLB X1

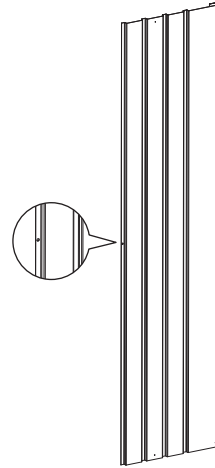



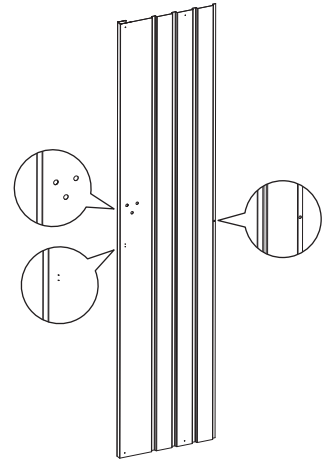

DRA X1





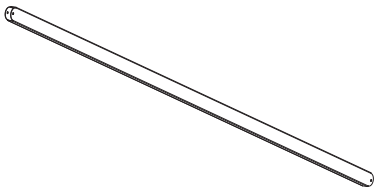
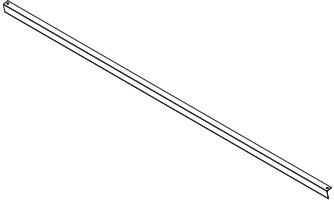
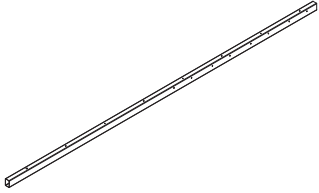
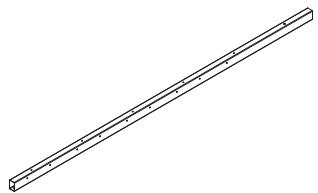
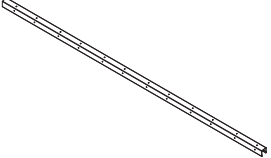
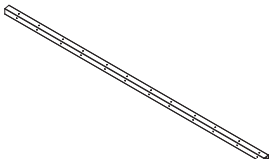
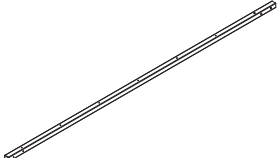
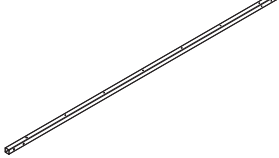
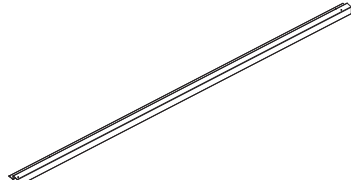

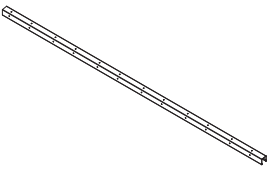

DRB X1

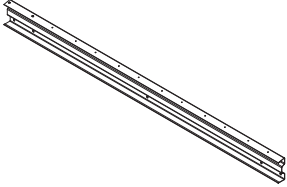
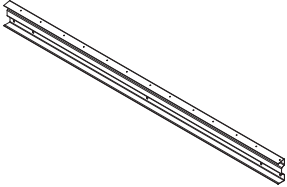
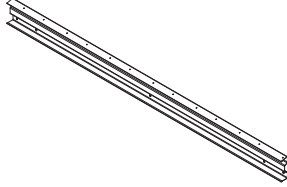
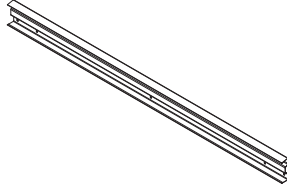
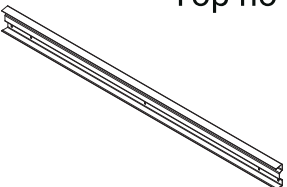
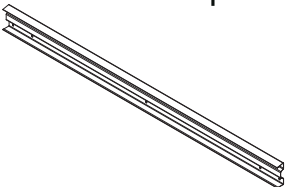
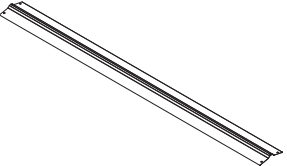
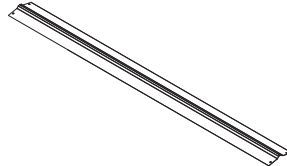



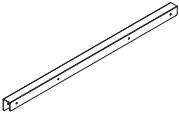

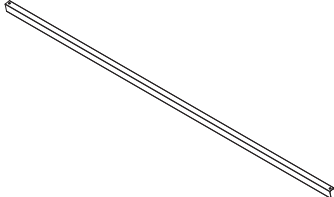
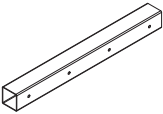

STRIPS

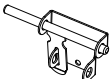
 <p>ULA X1</p>	 <p>UR1 X1</p>	 <p>DX2 X4</p>  <p>L16 X4</p>
 <p>UK1 X1</p>	 <p>UKIL X1</p>	
 <p>UE6 X2</p>	 <p>UE6R X2</p>	
 <p>UK2 X1</p>	 <p>UK2R X1</p>	
 <p>M21 X2</p>	 <p>M22 X2</p>	
 <p>UE6L X2</p>		

STRIPS

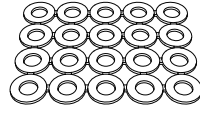
 <p>M16 X4</p>	 <p>M17 X4</p>		
 <p>M18 X4</p>	<p>Top no hole position</p>  <p>M16A X2</p>		
<p>Top no hole position</p>  <p>M17A X2</p>	<p>Top no hole position</p>  <p>M18A X2</p>		
 <p>16 X2</p>	 <p>21 X1</p>		
 <p>C4L X2</p>	 <p>C5 X4</p>	 <p>C4R X2</p>	 <p>GR1 X4</p>
 <p>20 X4</p>	 <p>GS1 X1</p>	 <p>L16BX2</p>	
 <p>GR X1</p>			

STANDARD

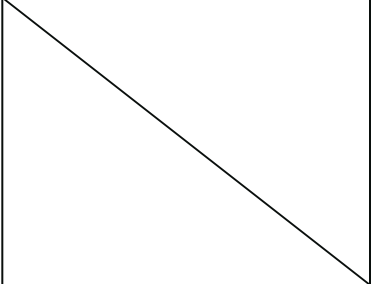
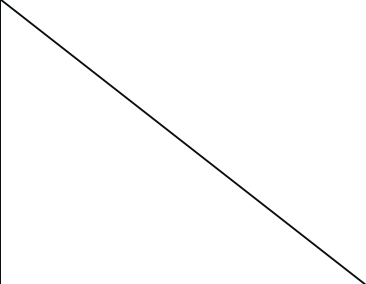
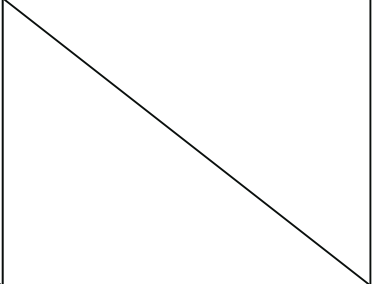
 DG X1	 DF X1	 DC X2	 DH X4
 C2 X4	 V2 X545	 GC X4	 GE X2
 V1 X176			

SCREW

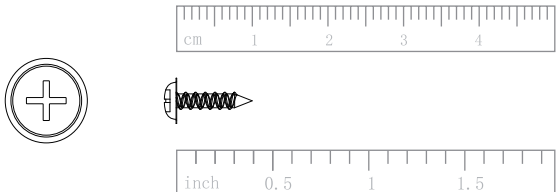
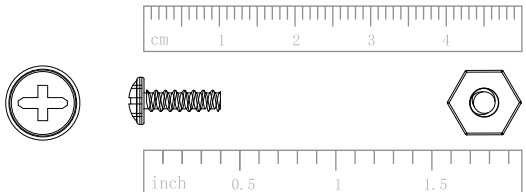
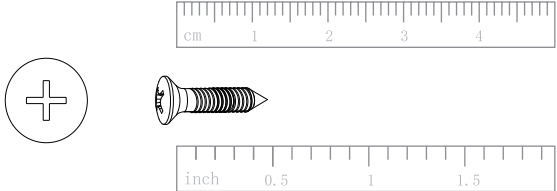
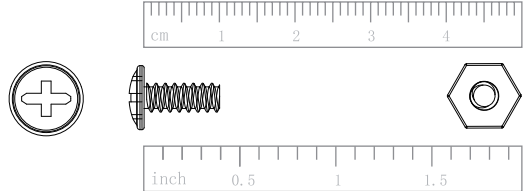
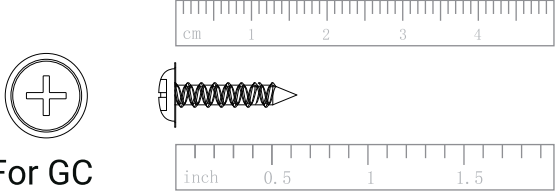
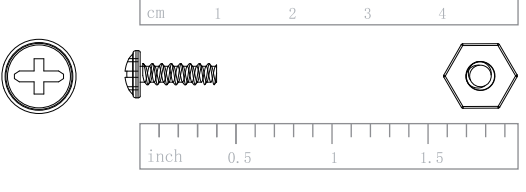
 F1(X666) M4*10	 F2(X90) M4*10
 F3(X32) M5*12	 F4(X5) M6*10
 For GC F5(X4) M4*16	 F6(X4) M4*16

STEP 1

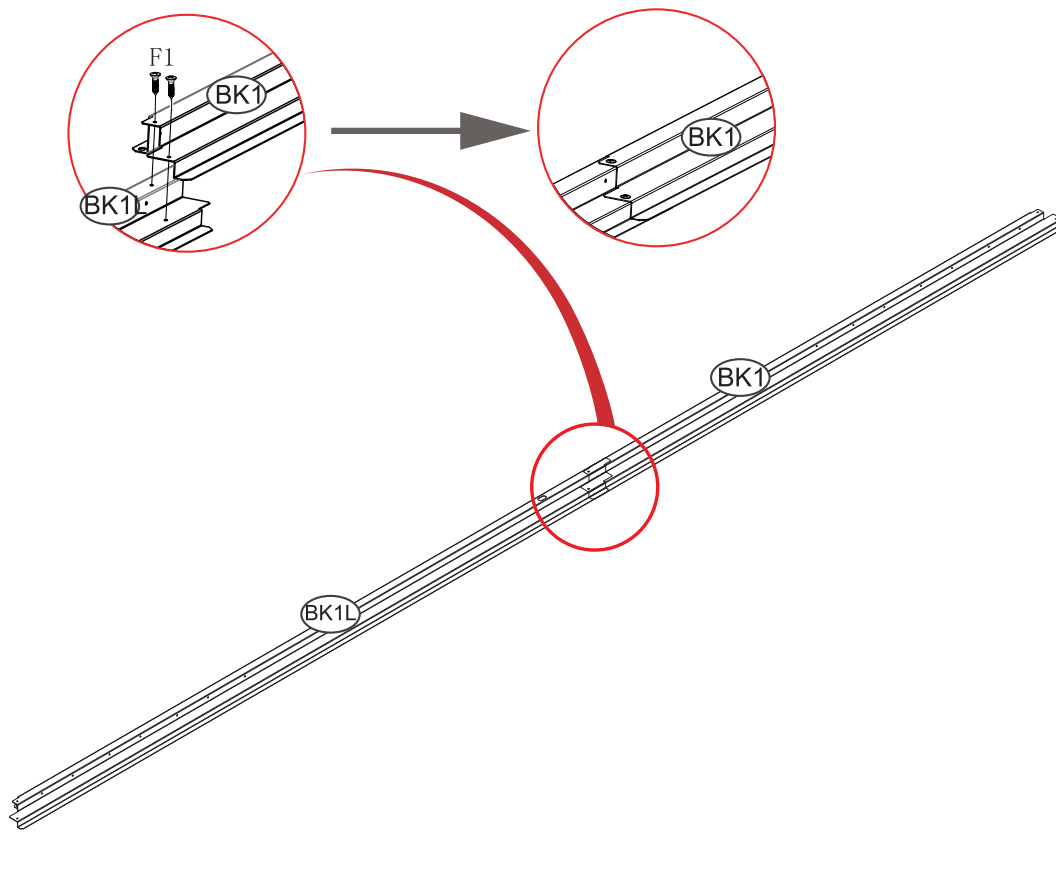

STEP 2

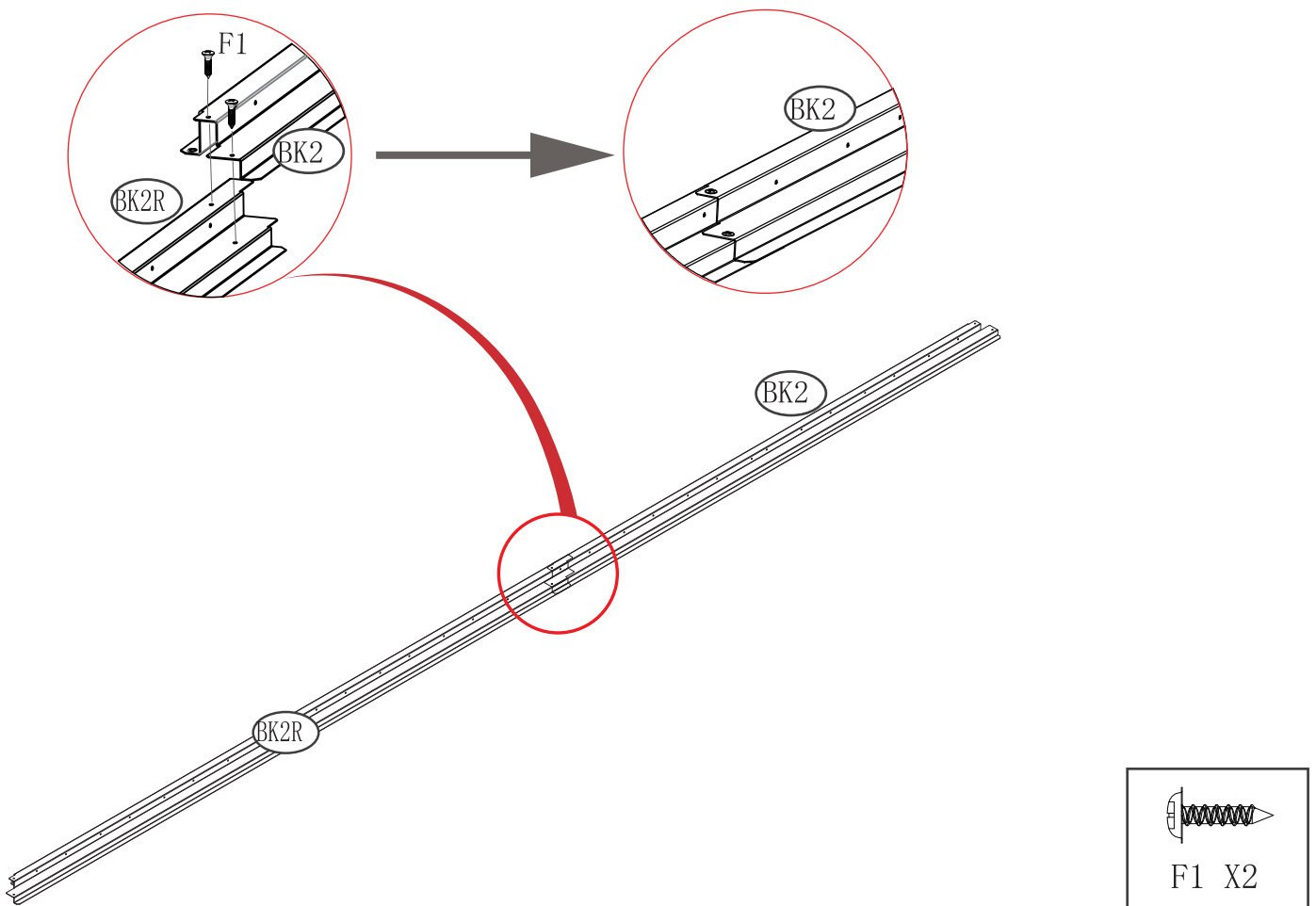

STEP 3

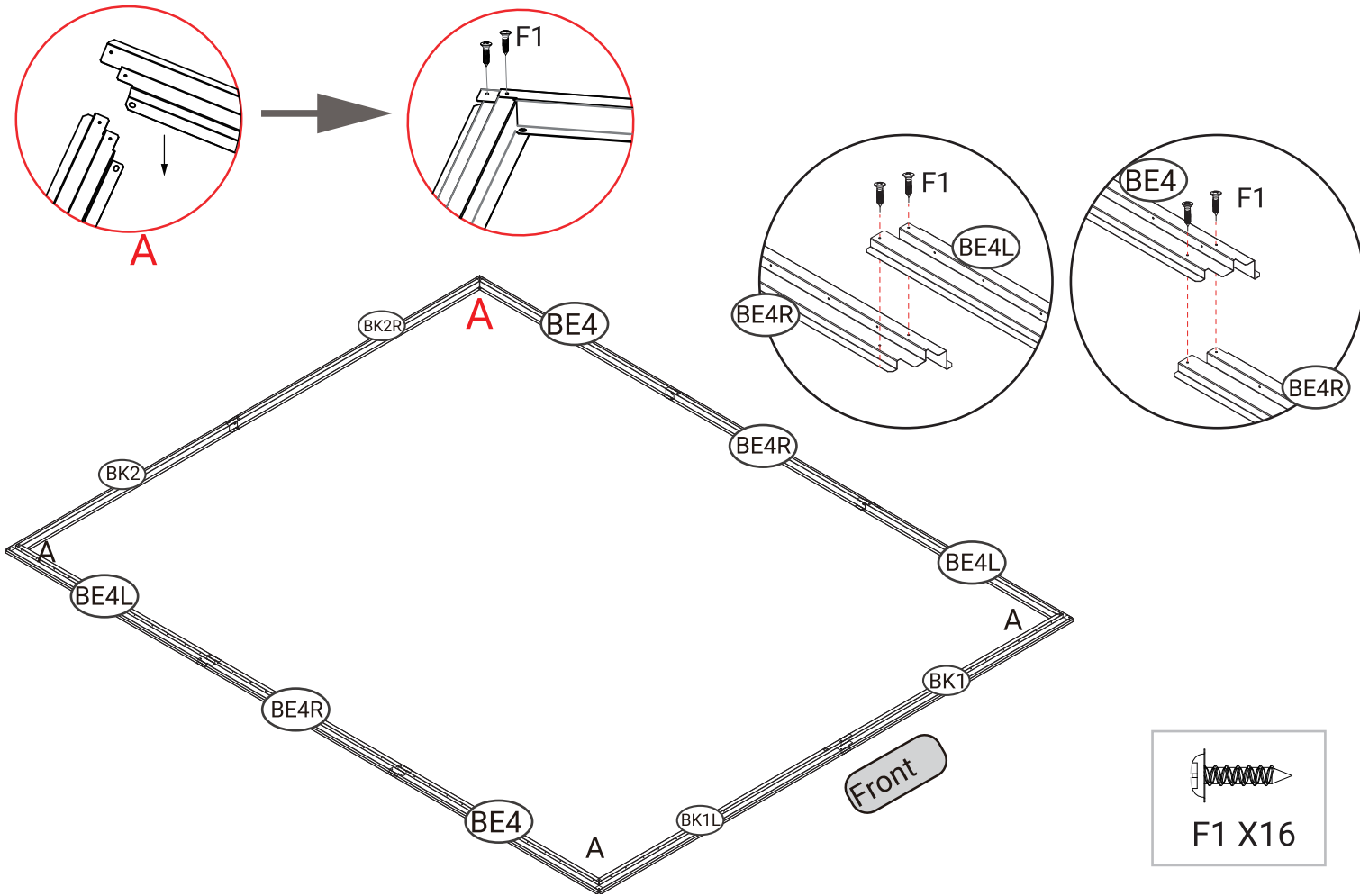

STEP 4

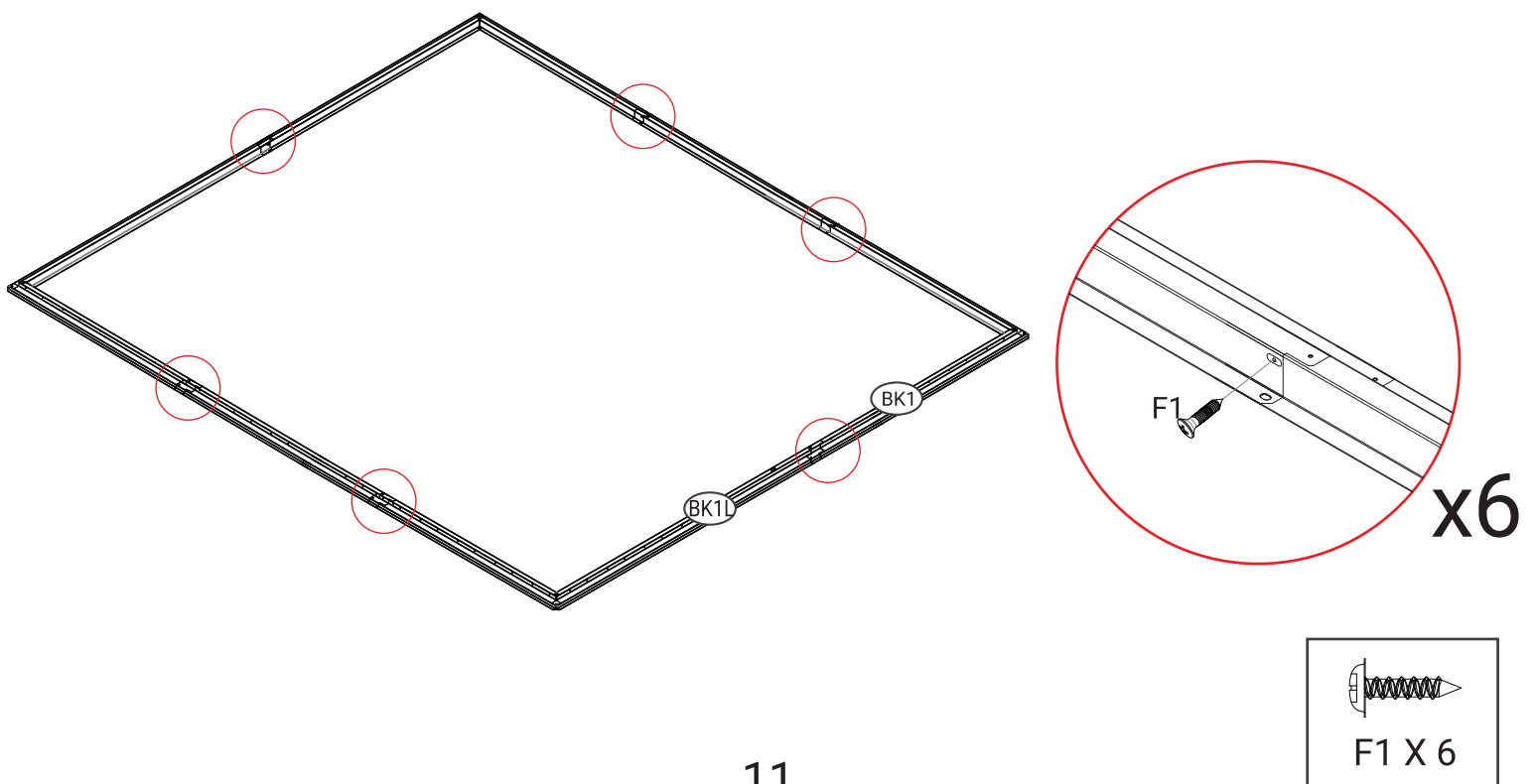

STEP 5

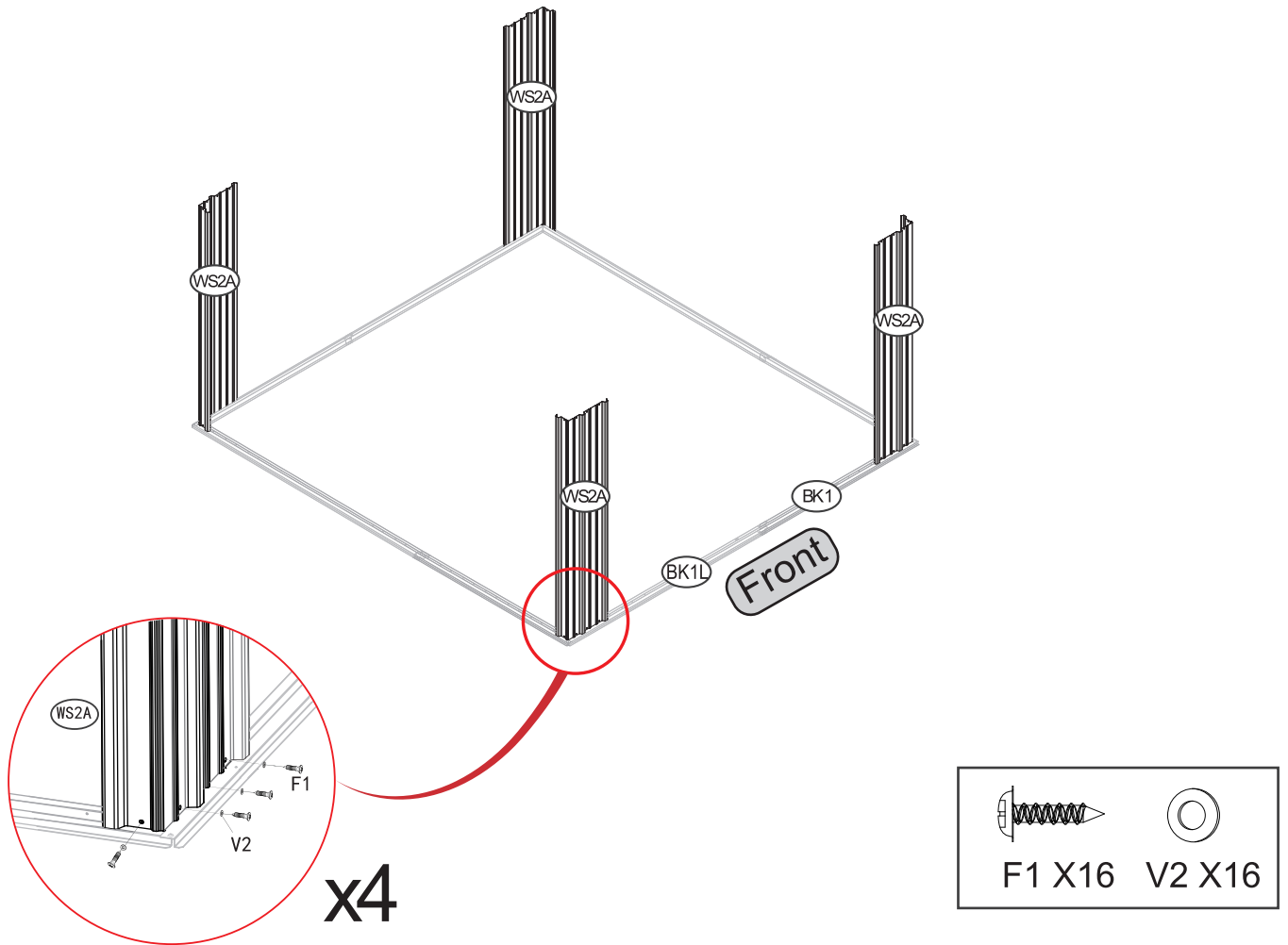

STEP 6

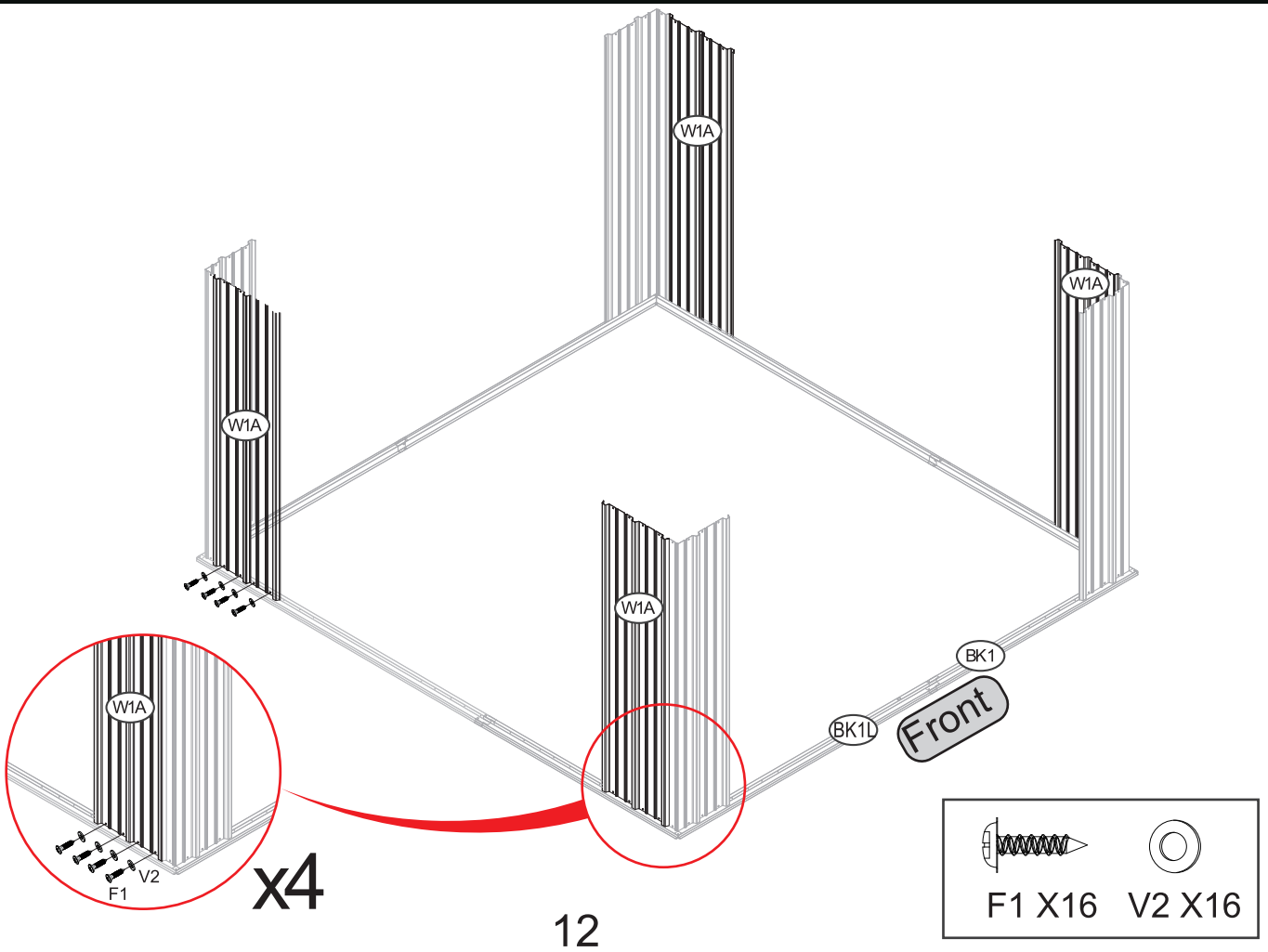

STEP 13

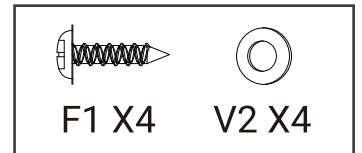
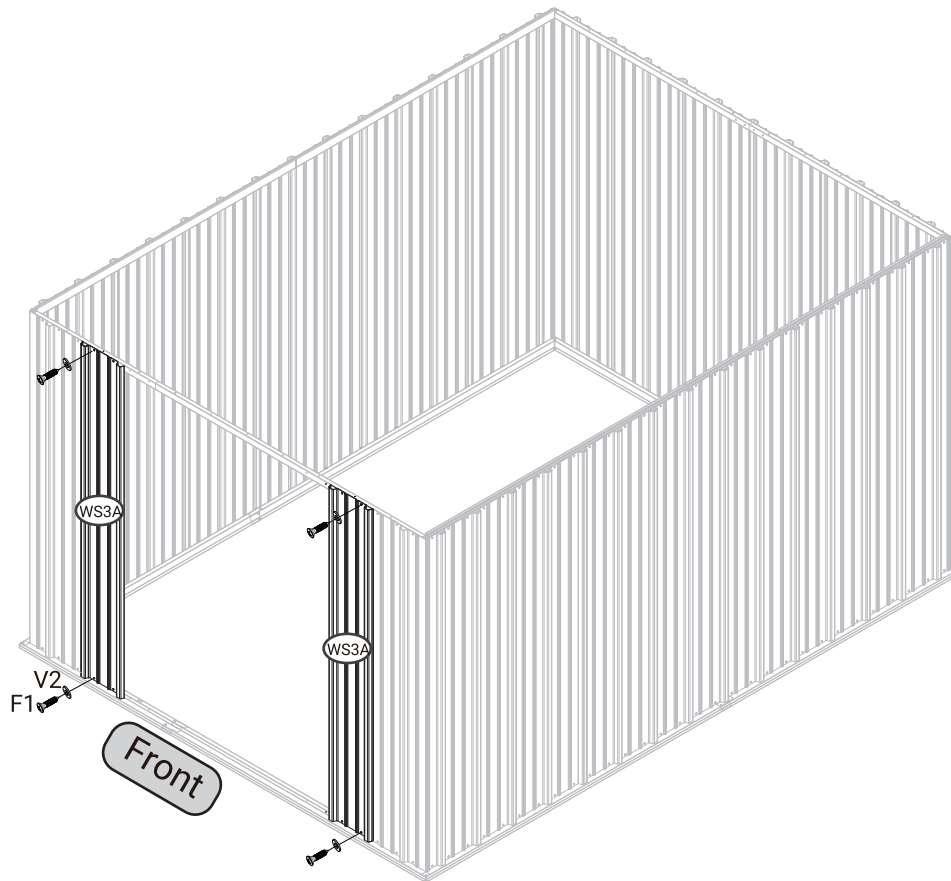

STEP 14

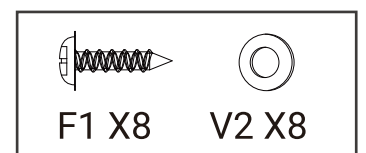
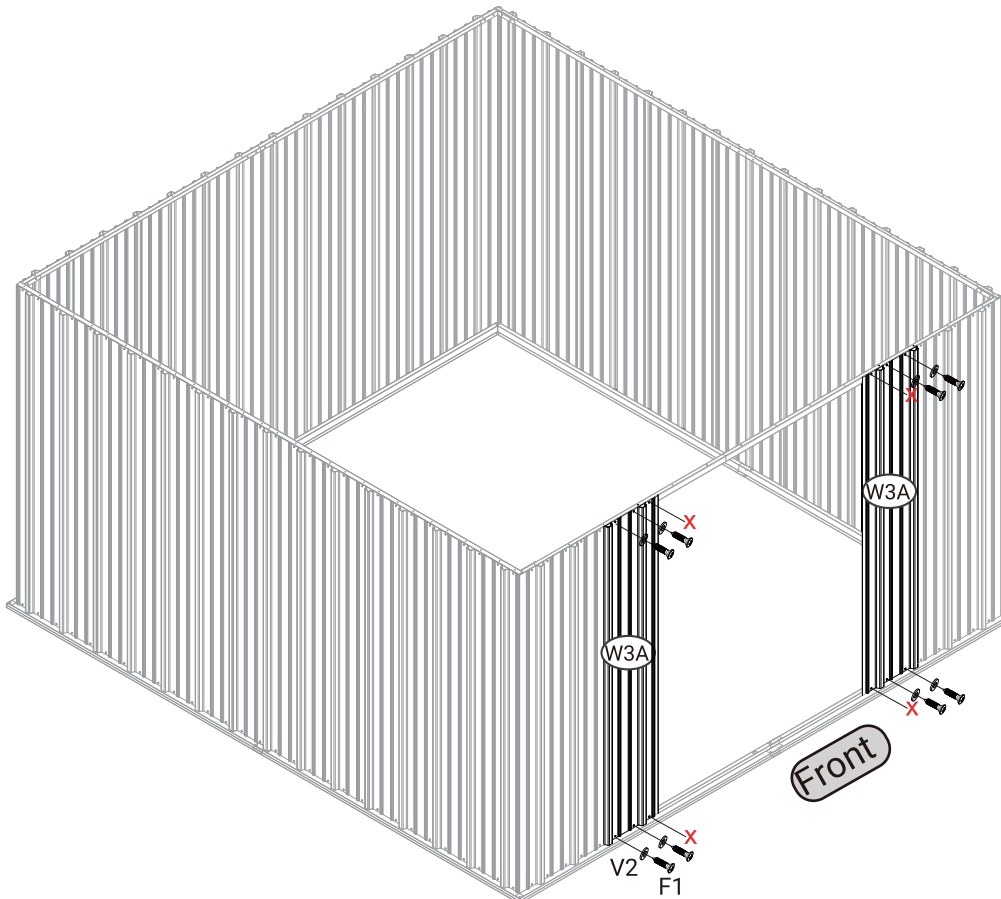

STEP 15

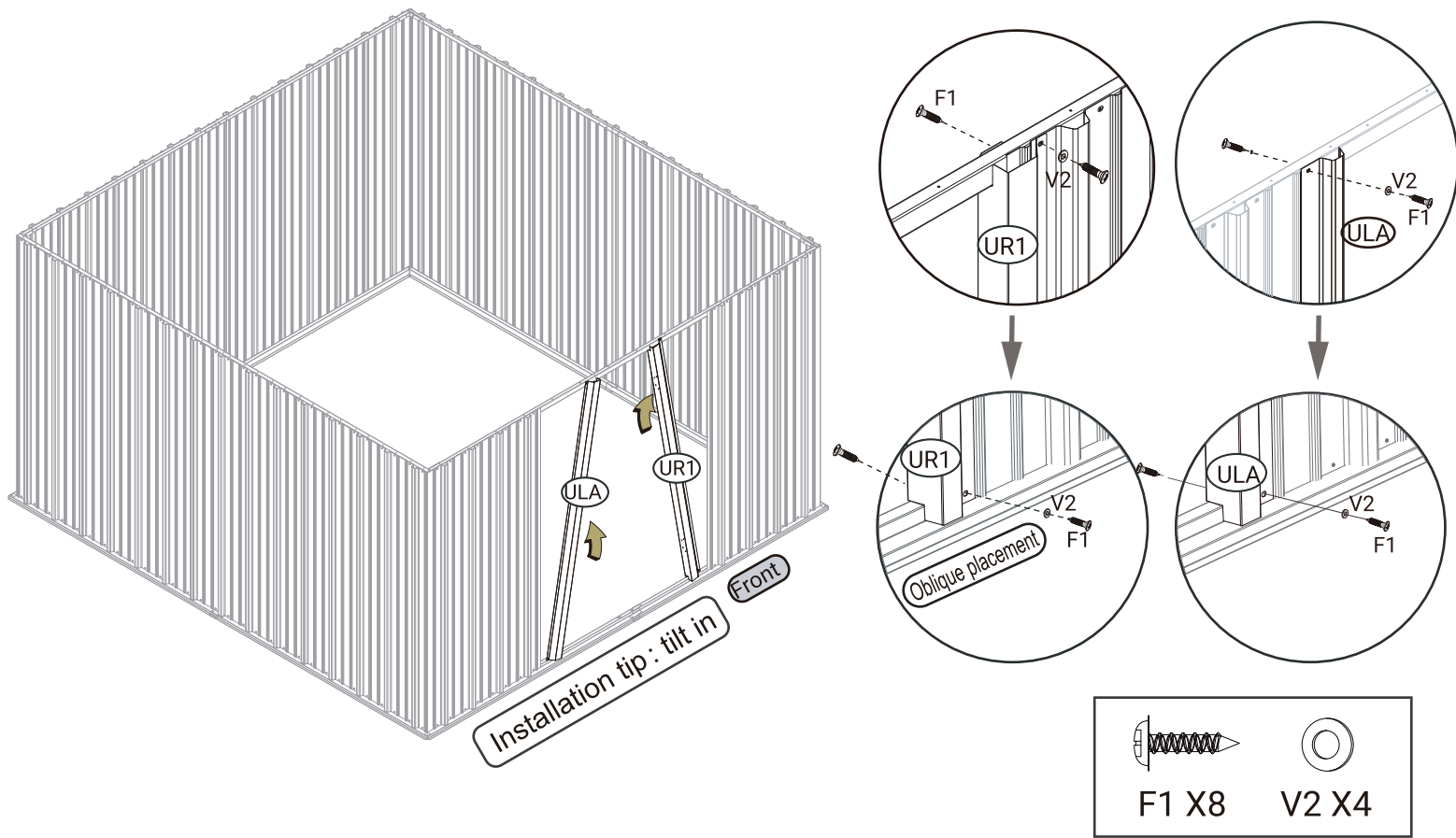

STEP 16

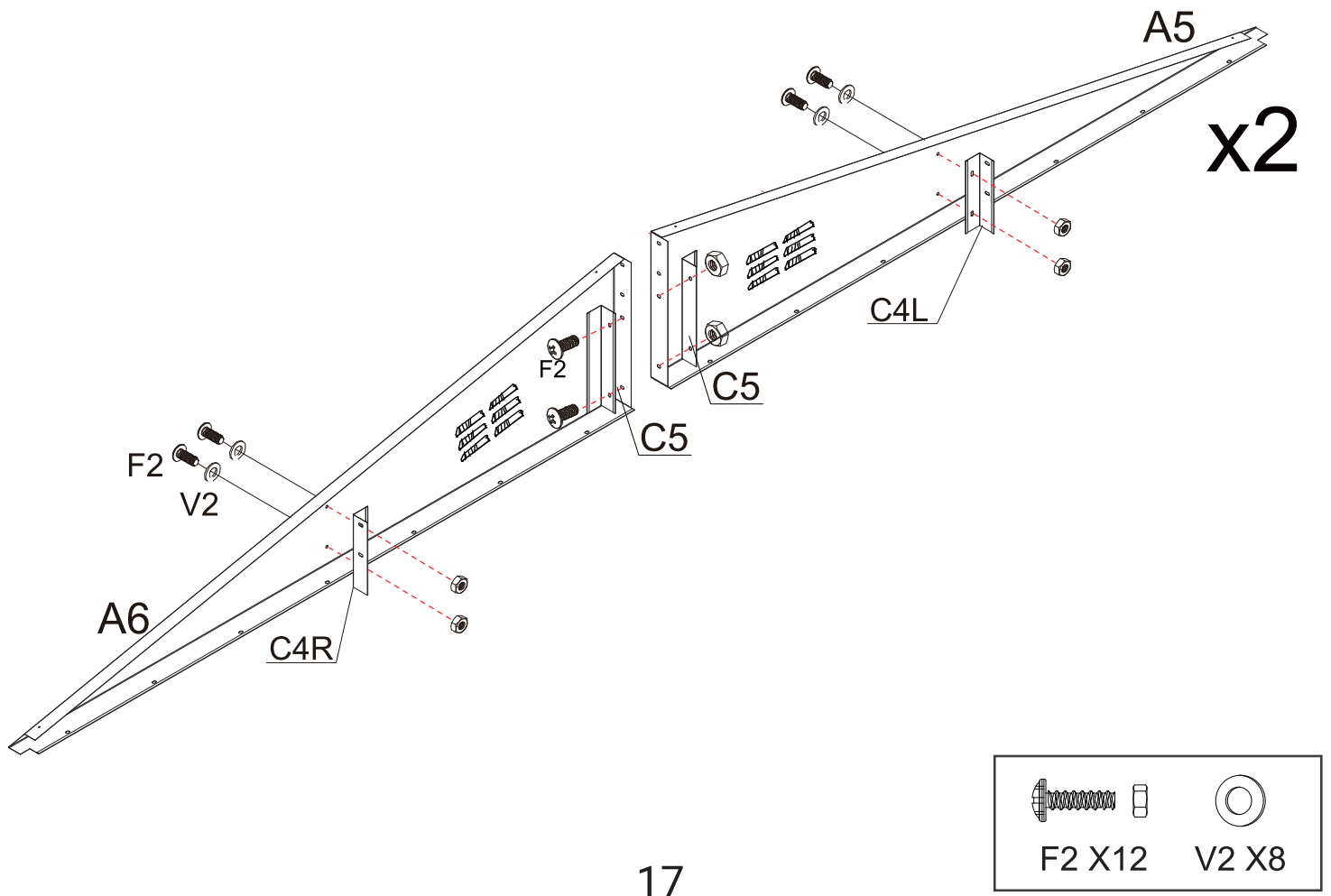

X2

Behind

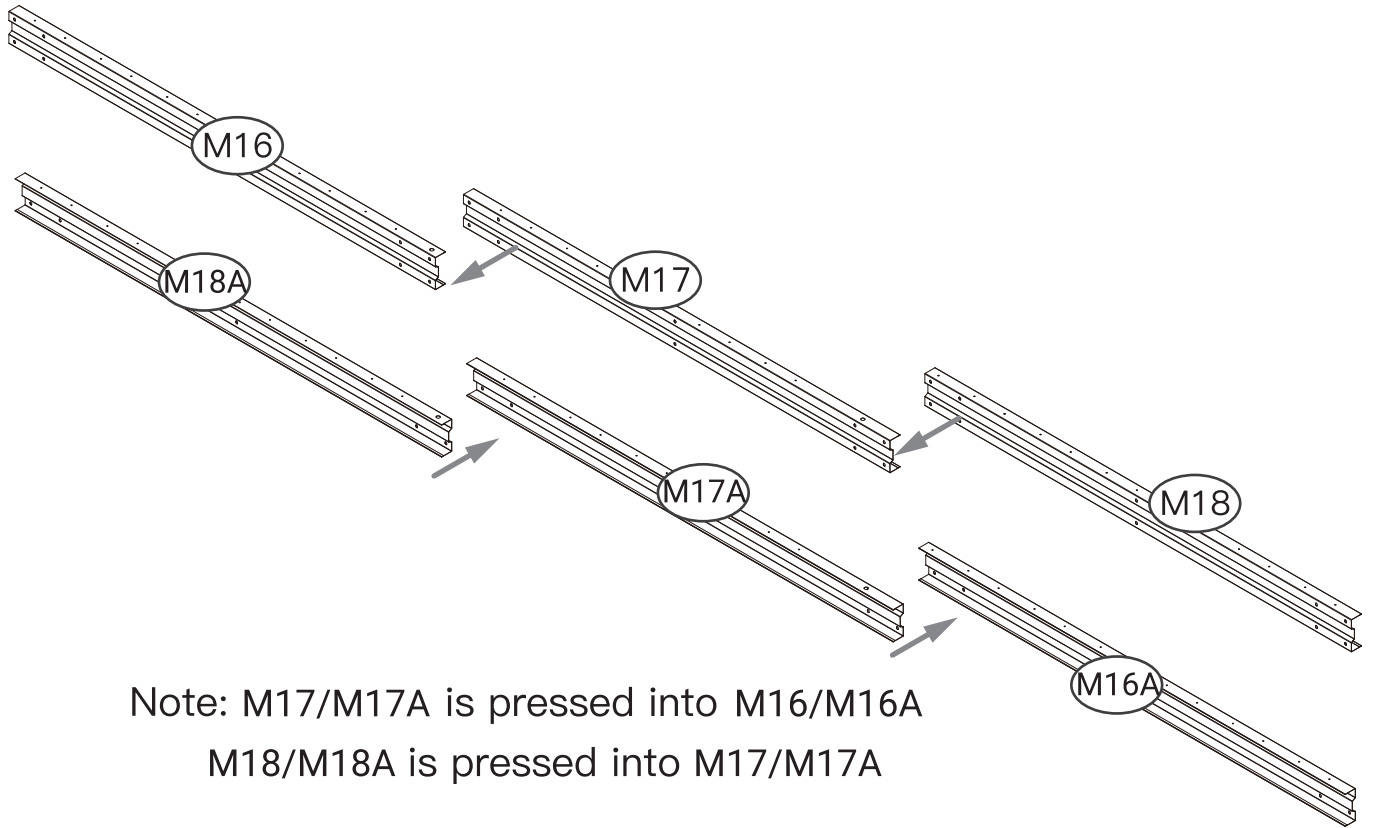

Note: M17/M17A is pressed into M16/M16A
M18/M18A is pressed into M17/M17A

In front

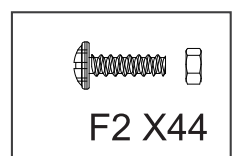
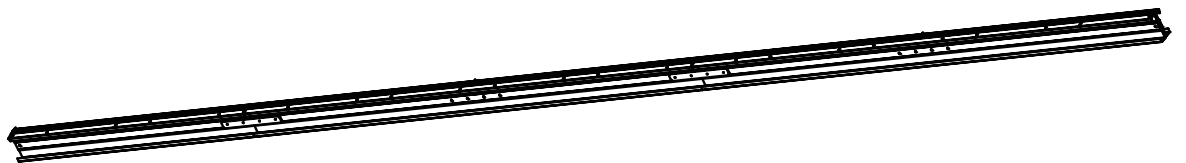

STEP 19

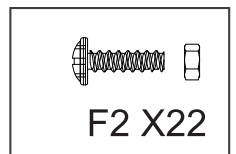
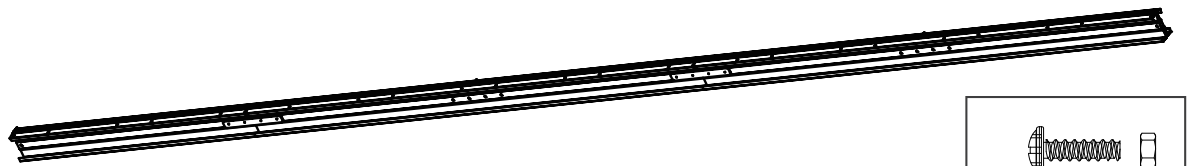
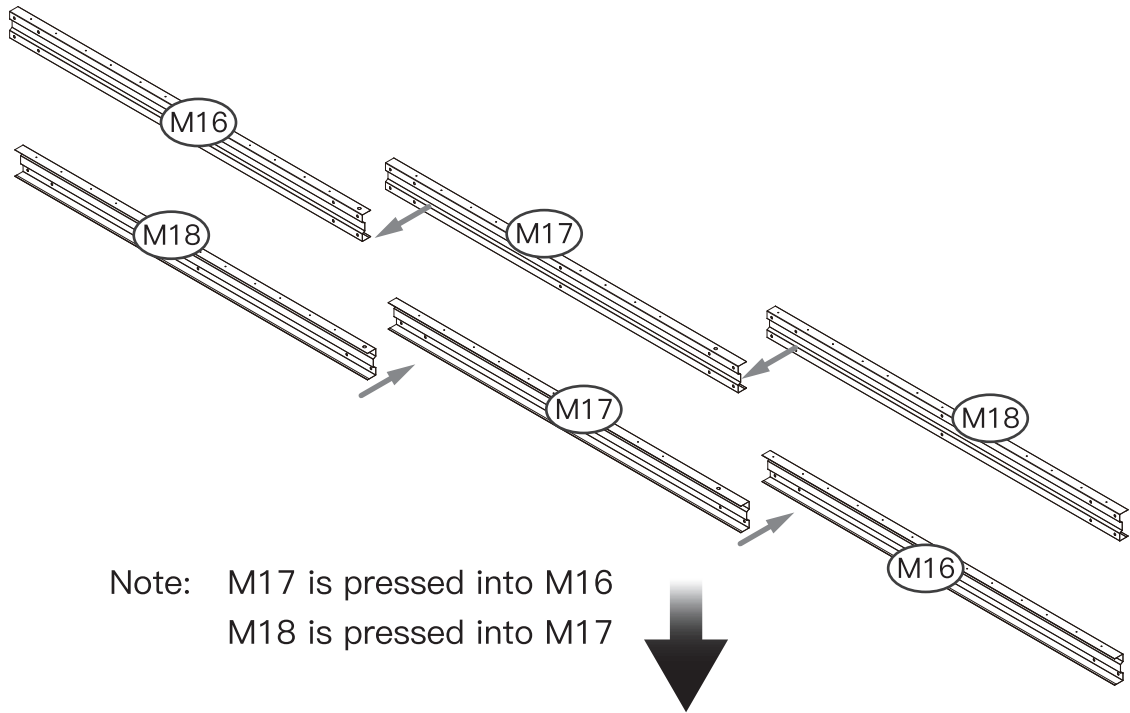

STEP 20

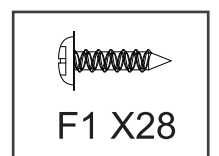
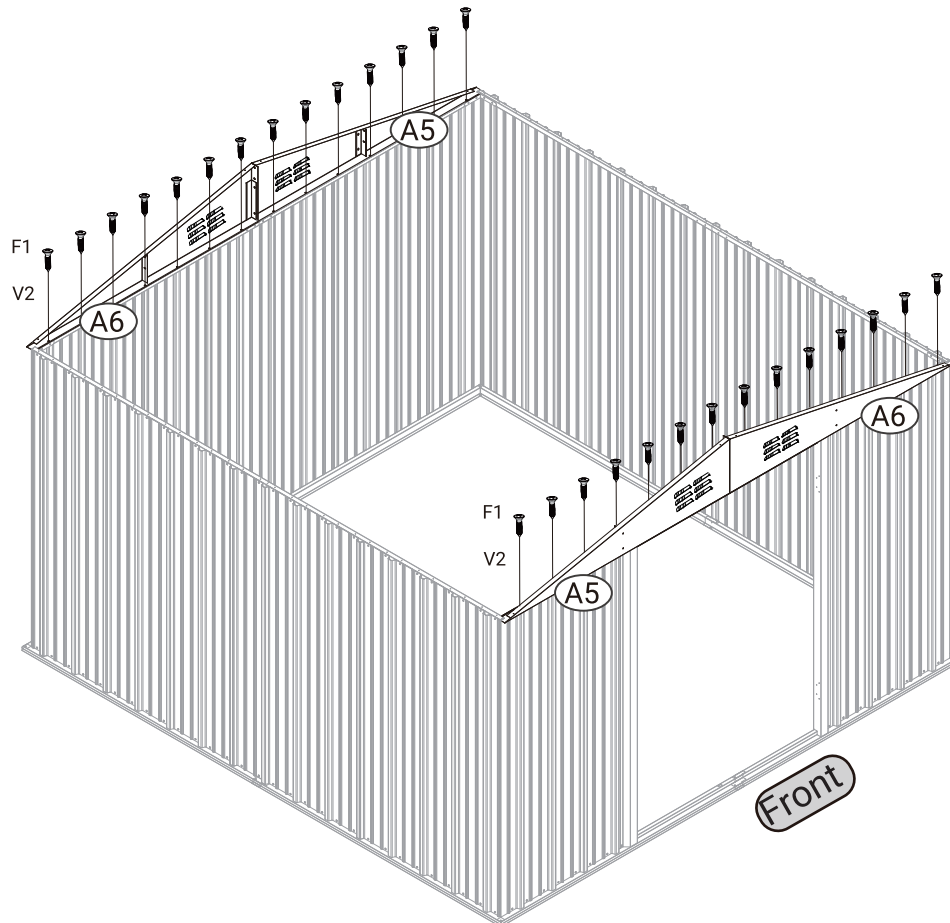

STEP 21

Tighten all screws

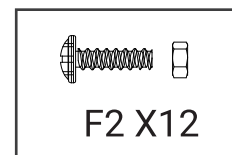
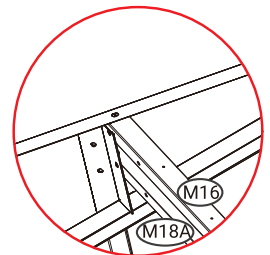
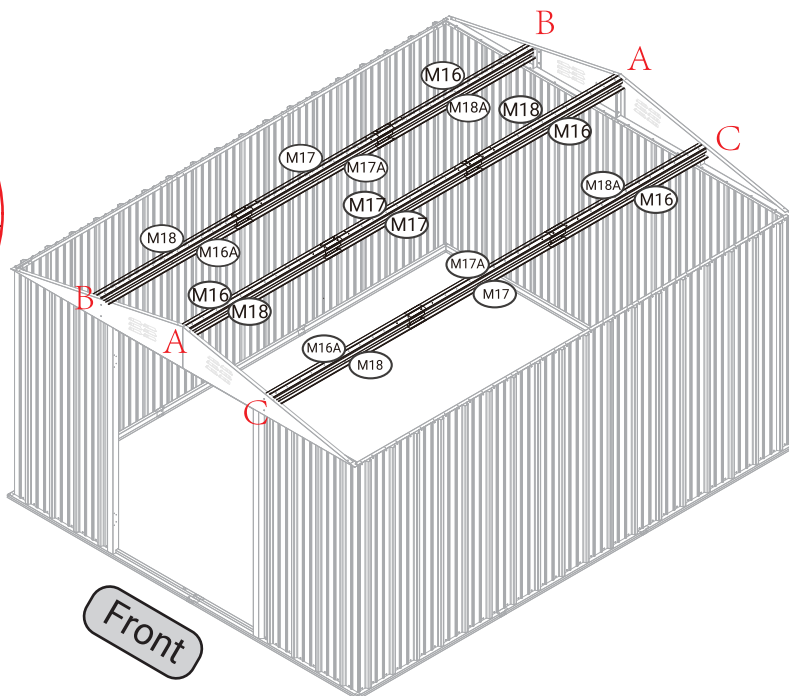
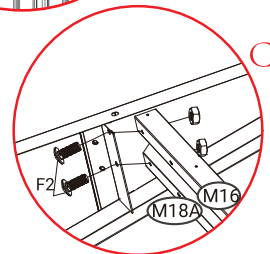
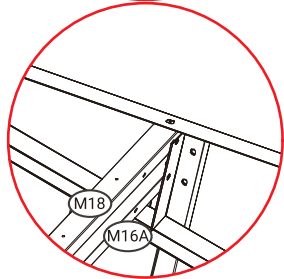
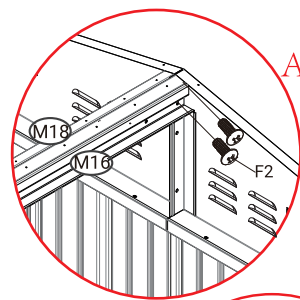
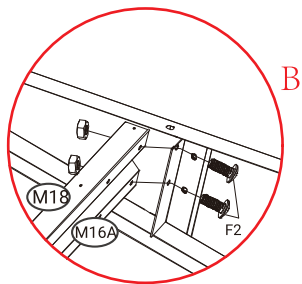

STEP 22

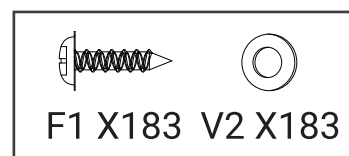
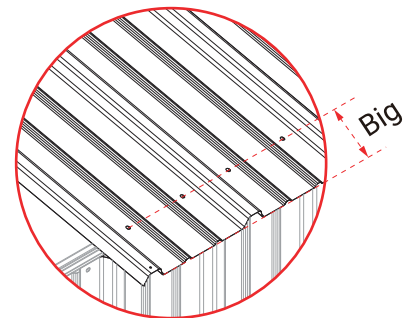
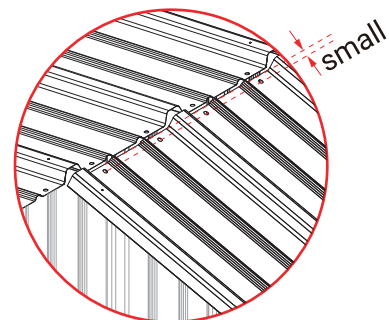
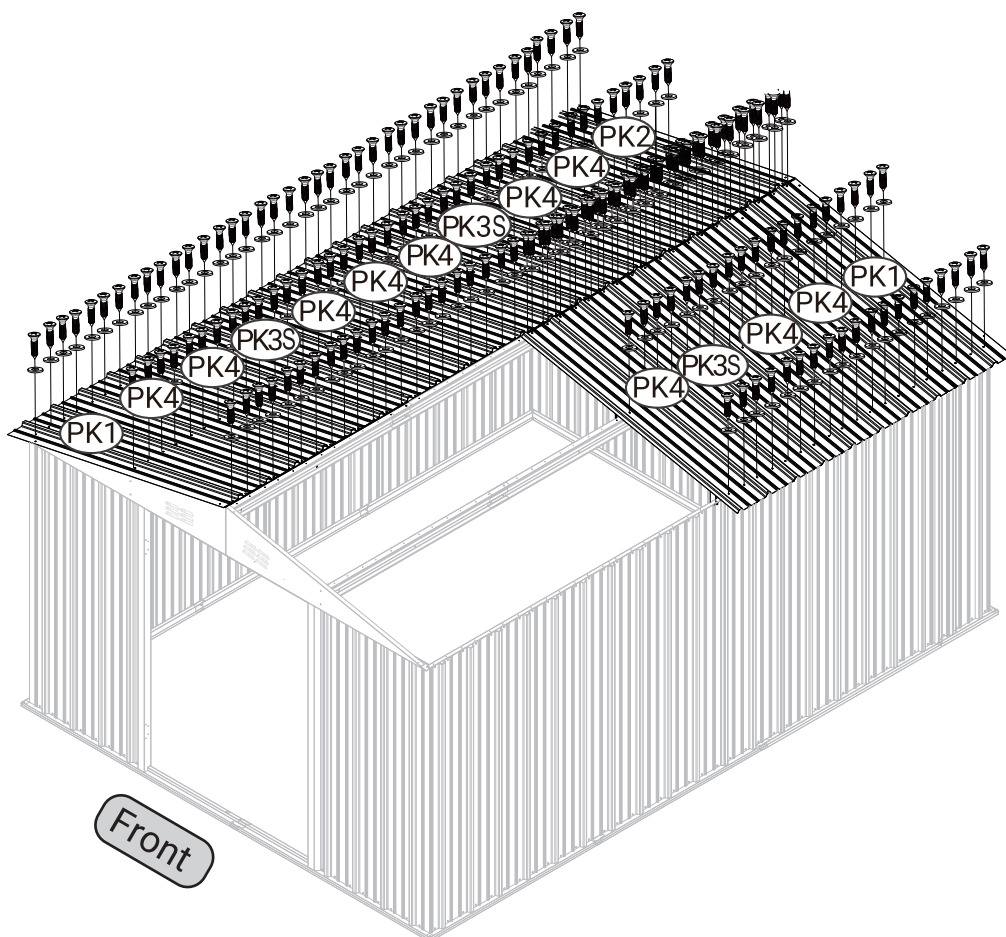

STEP 23

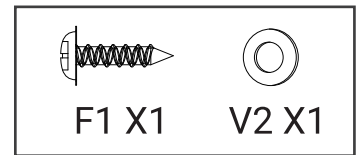
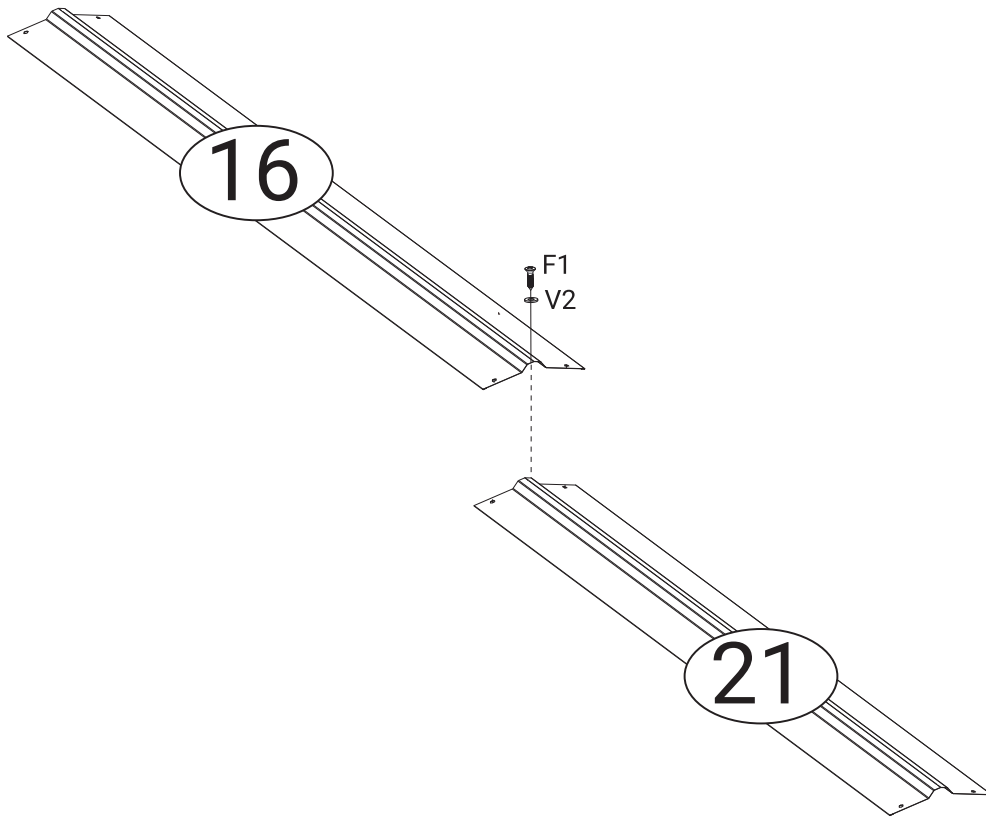

STEP 24

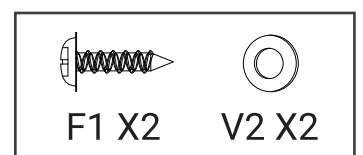
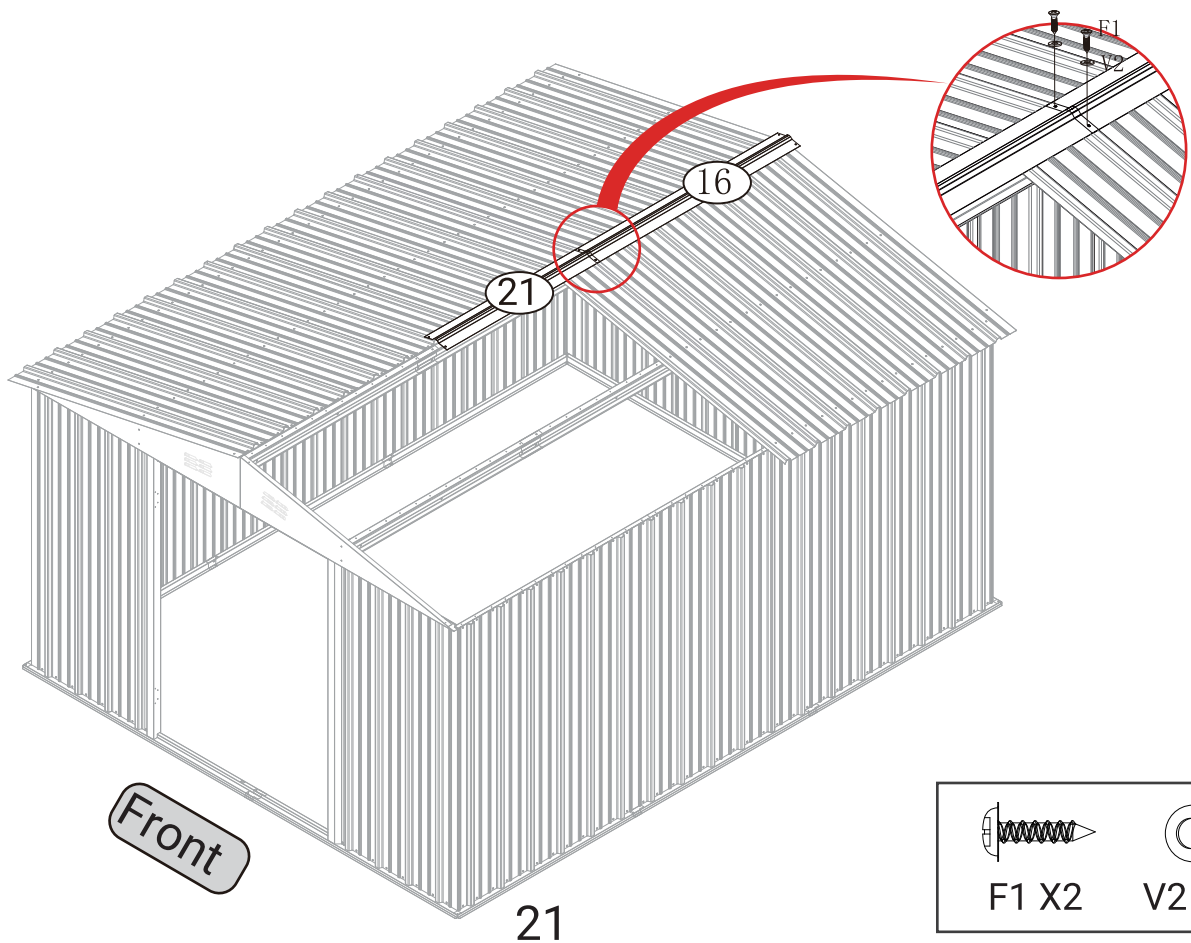

STEP 25

Installation tips : You need to gently lift the 21 and then screw it.

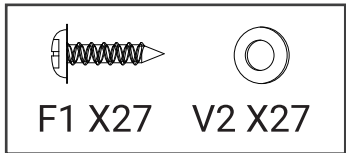
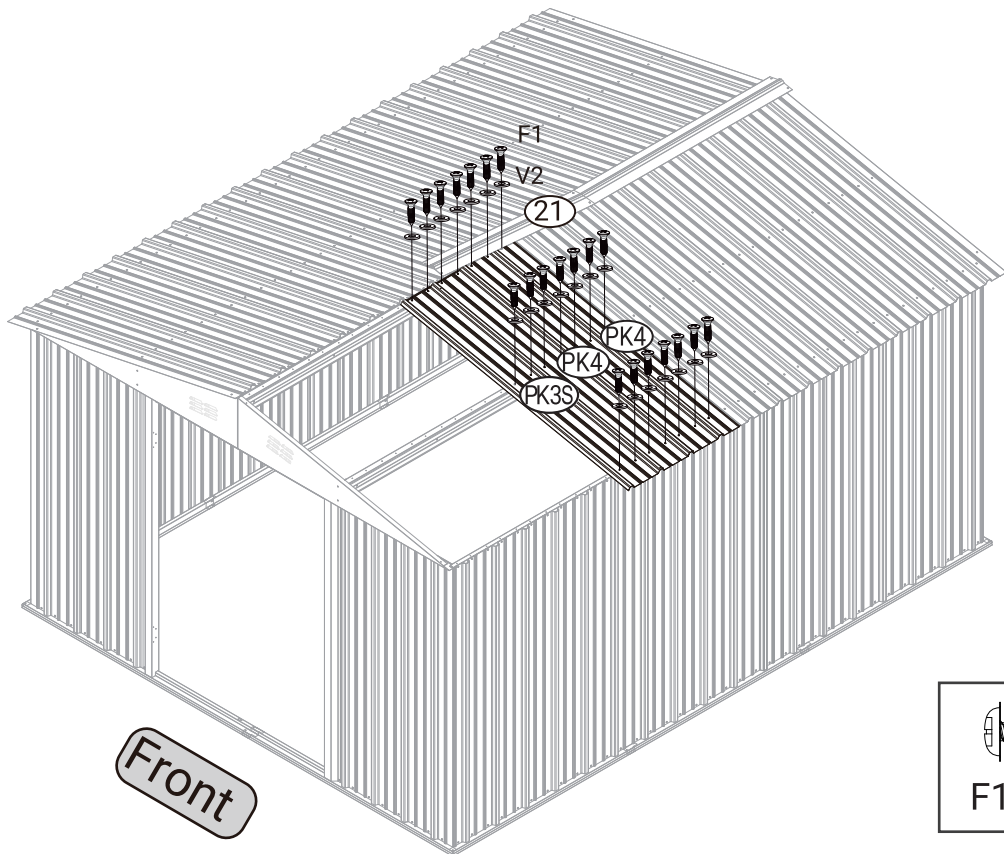

STEP 26

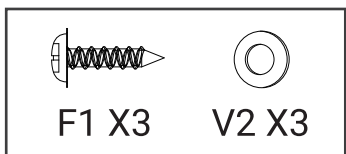
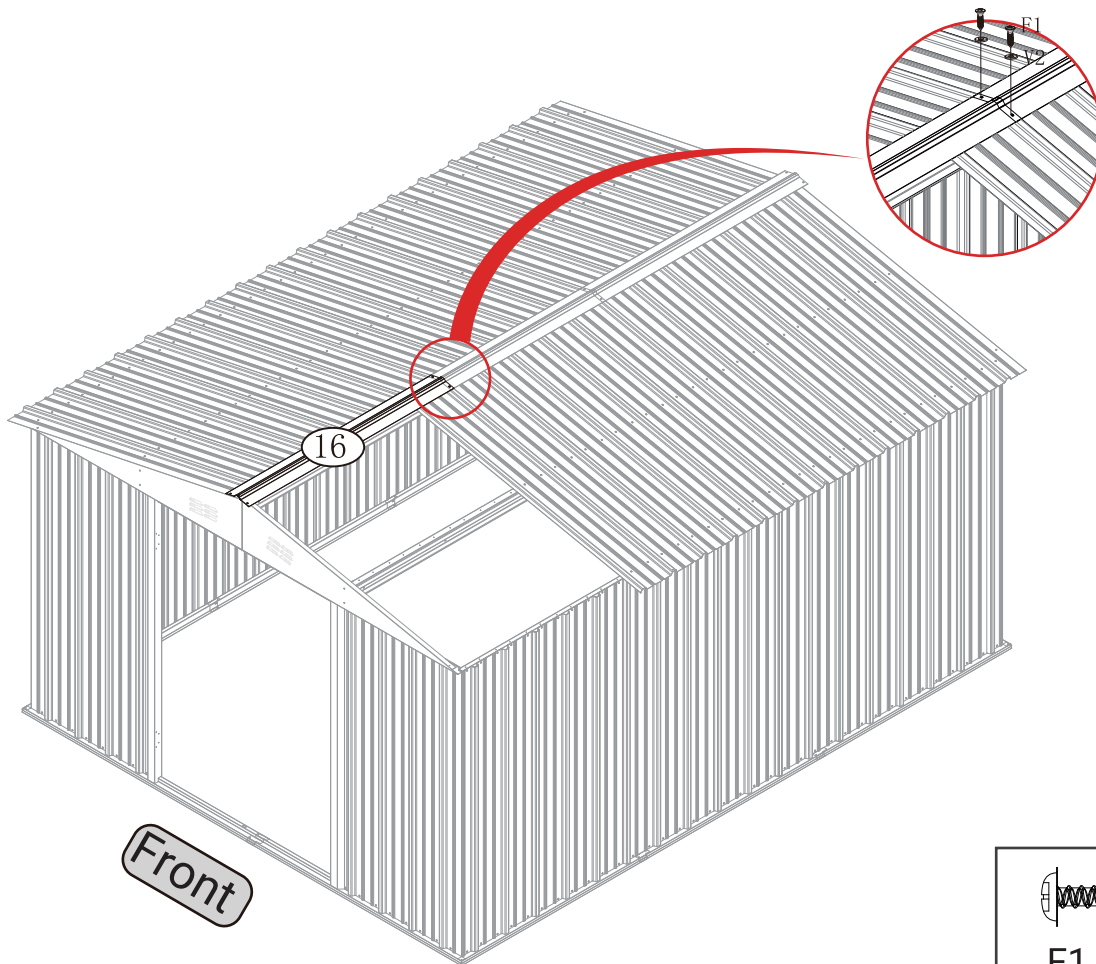

STEP 27

Installation tips : You need to gently lift the 16 and then screw it.

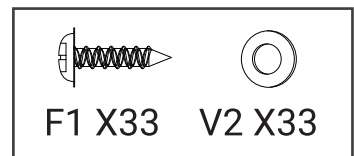
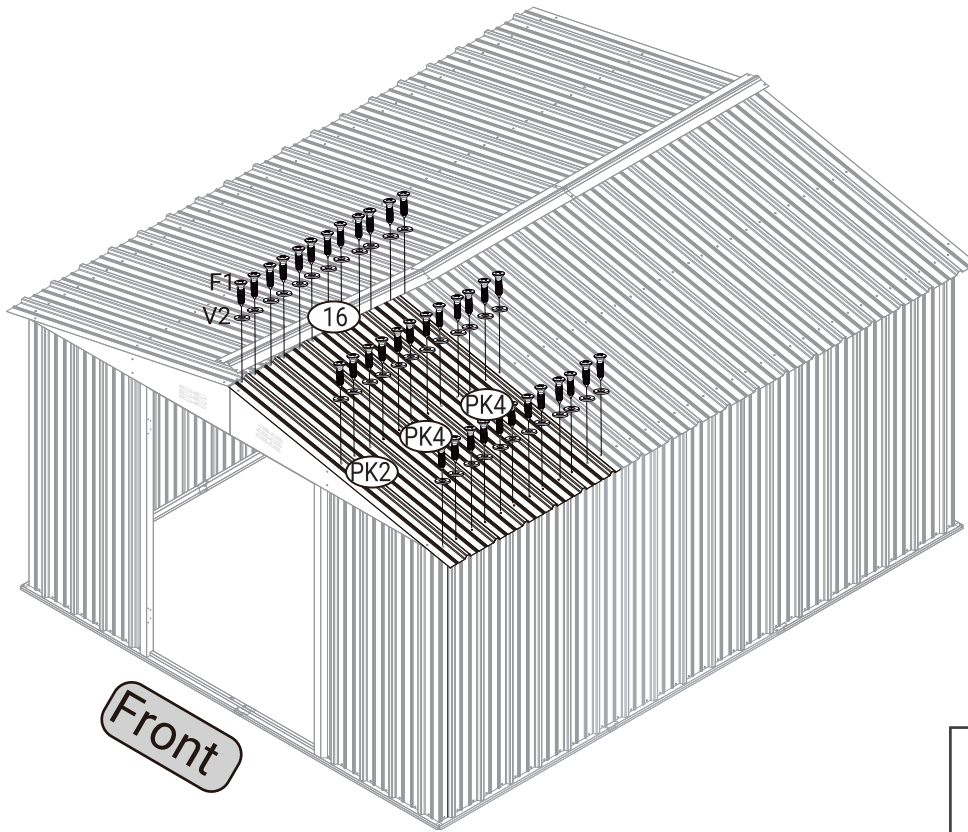

STEP 28

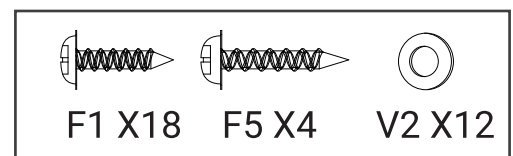
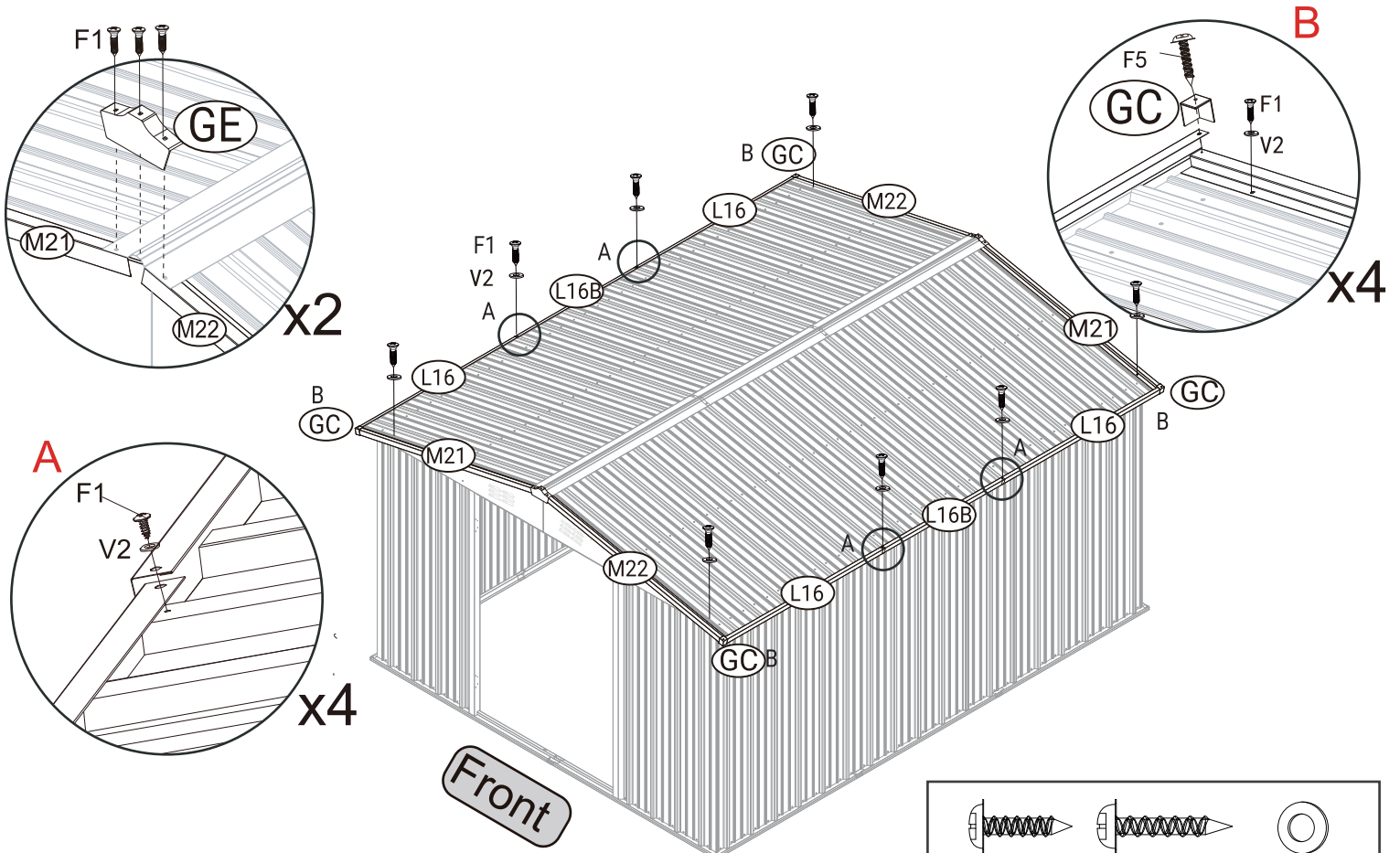

STEP 29

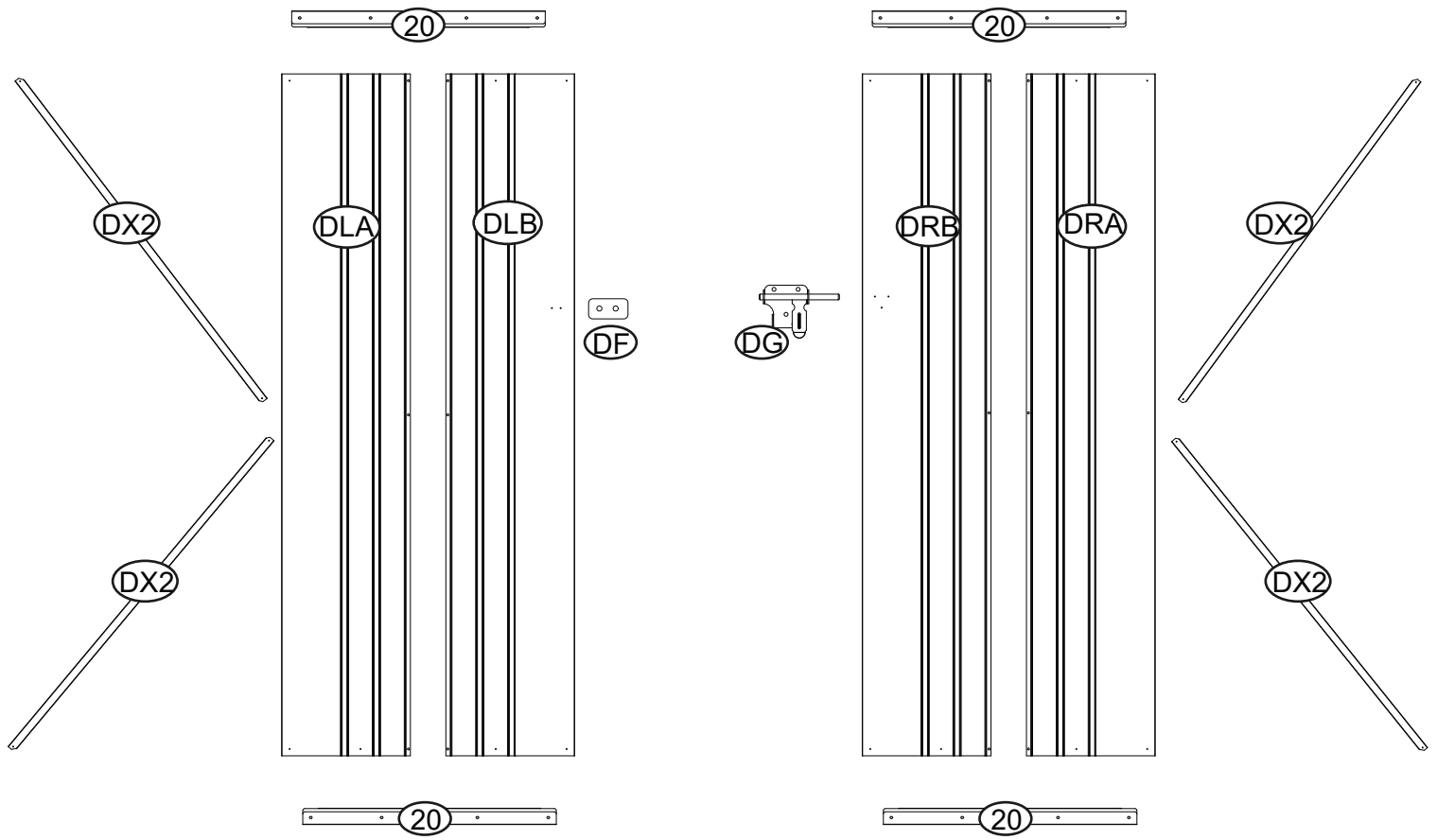

STEP 30

The other door operates the same way

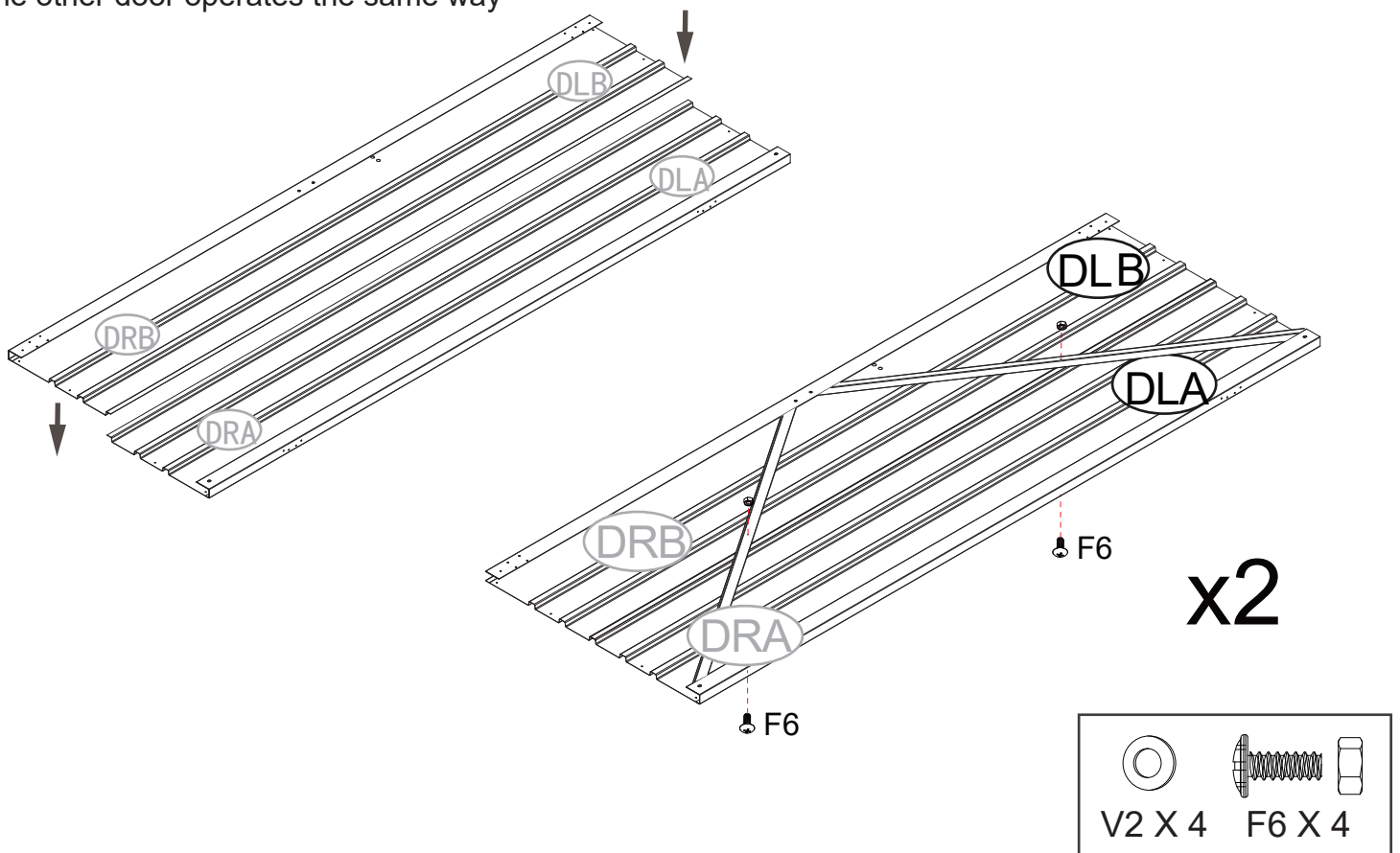

STEP 31

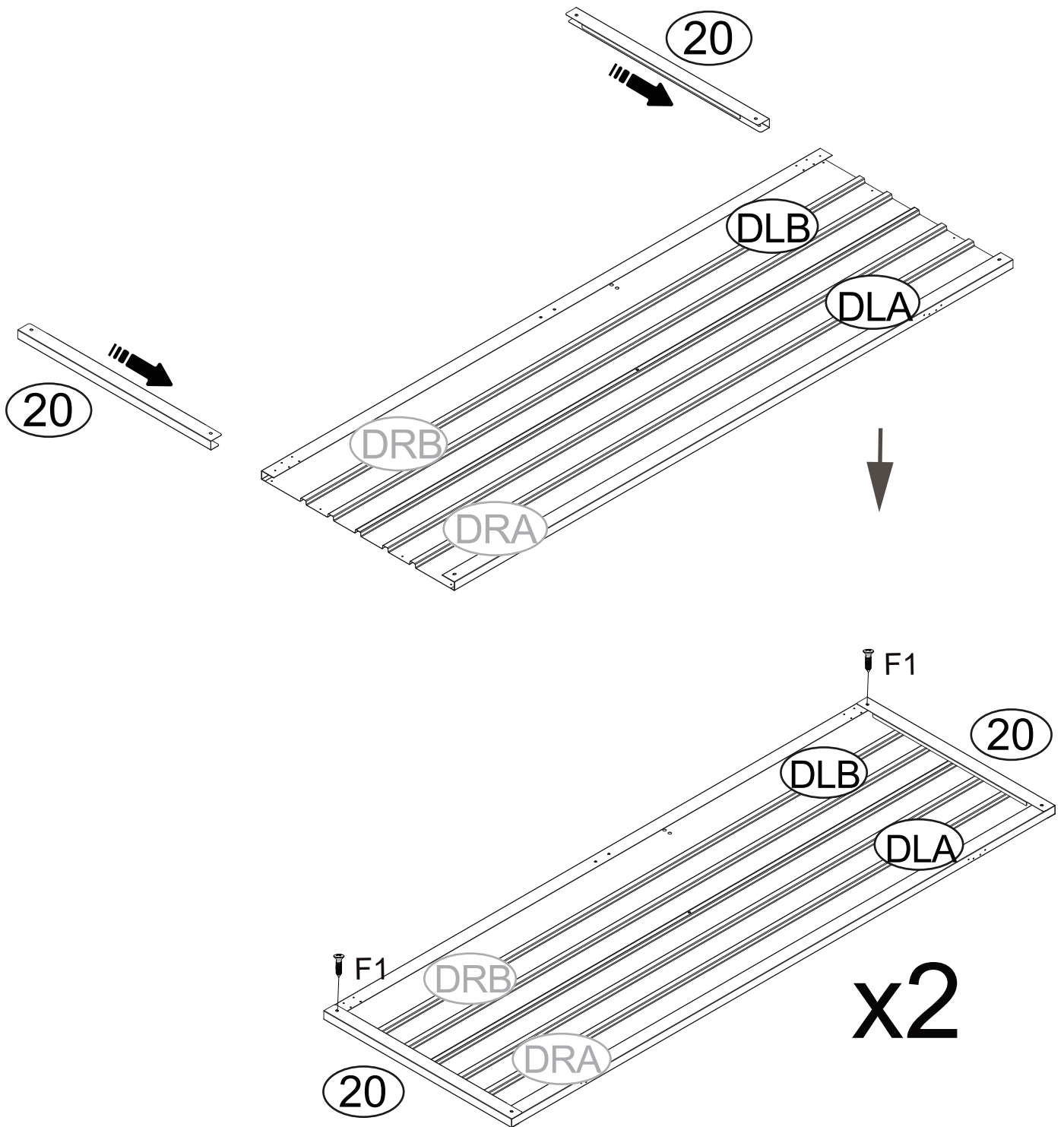

The other door operates the same way

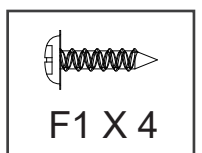

STEP 32

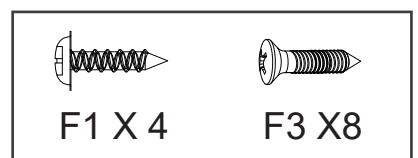
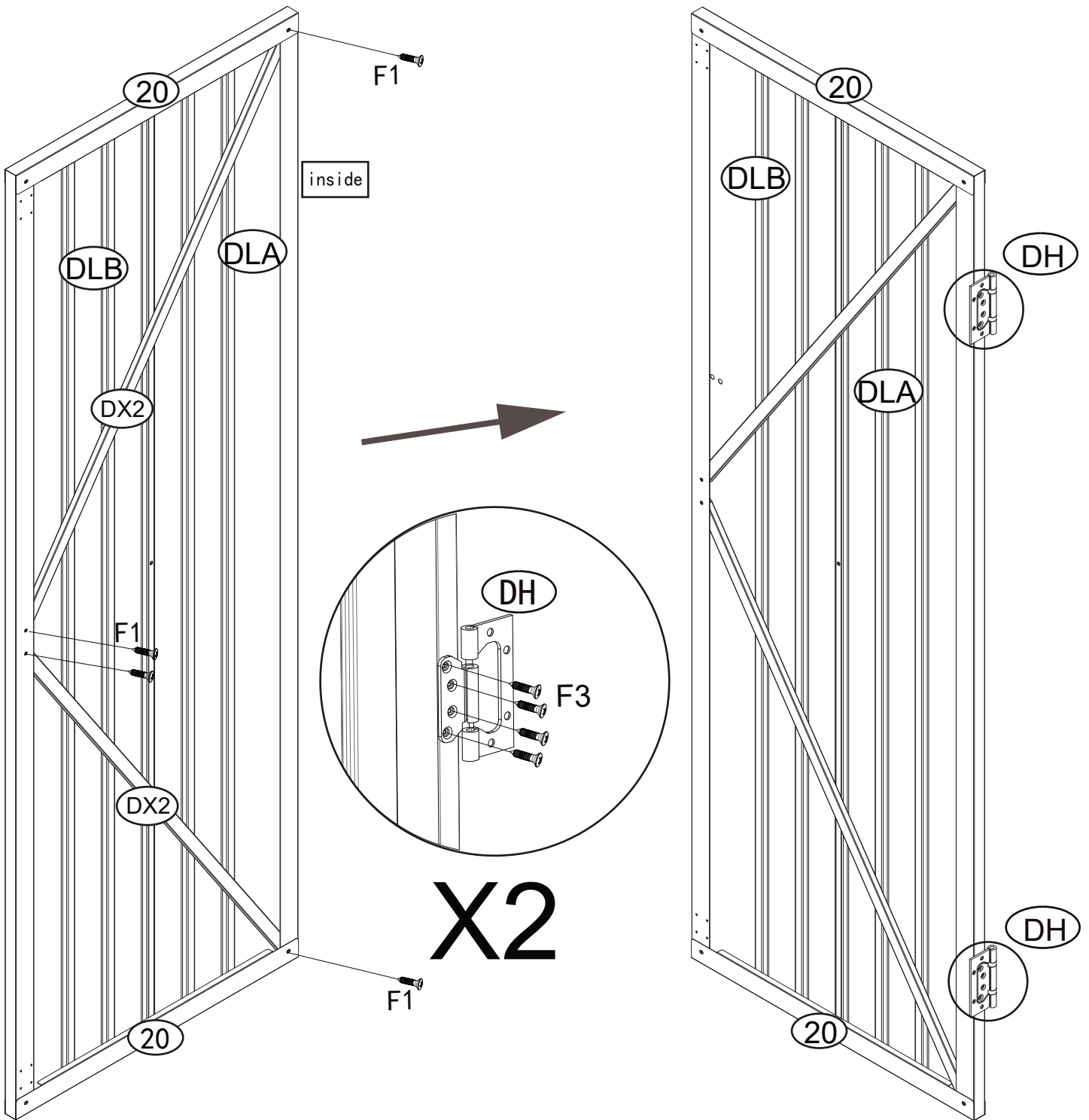

STEP 33

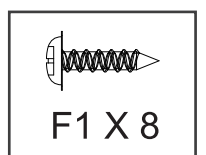
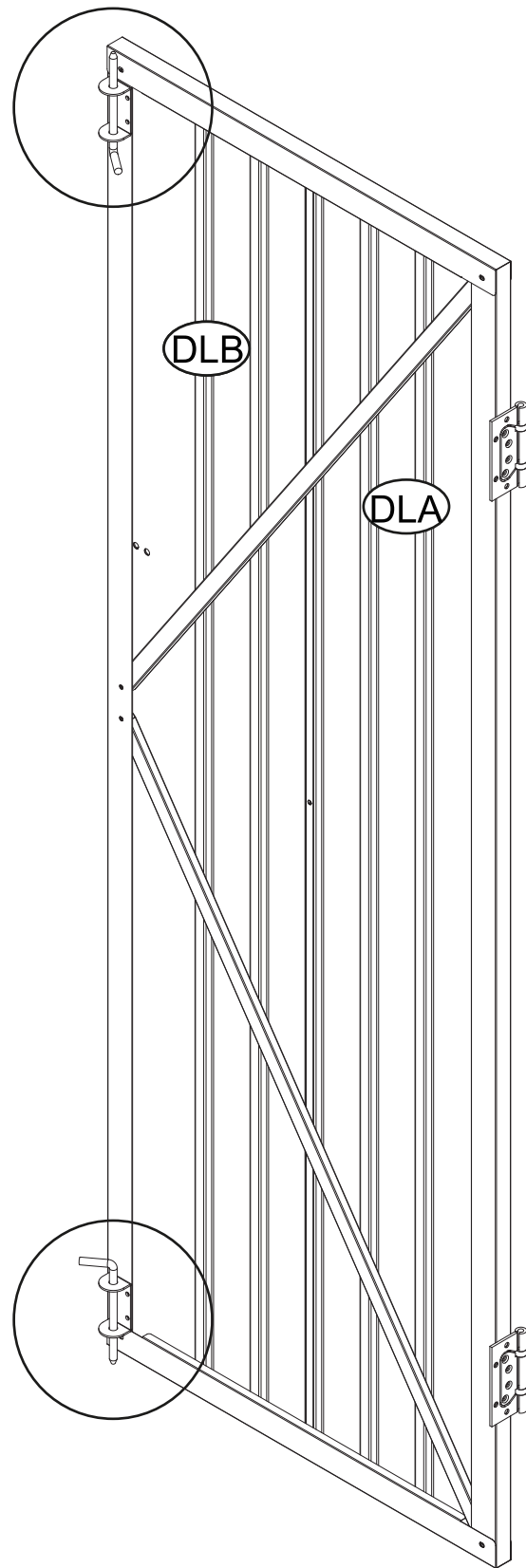
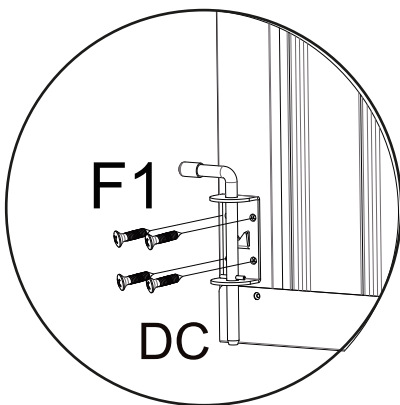
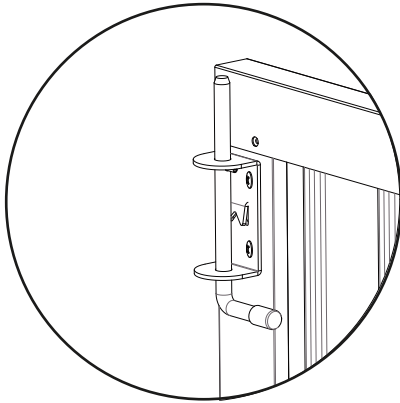
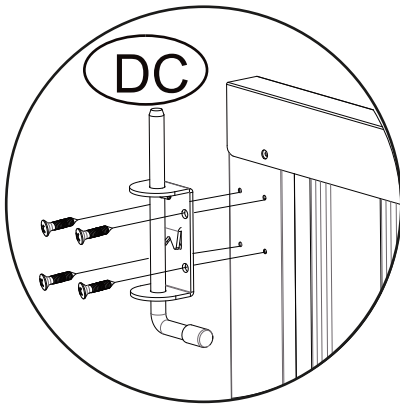

STEP 34

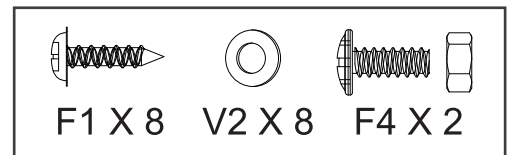
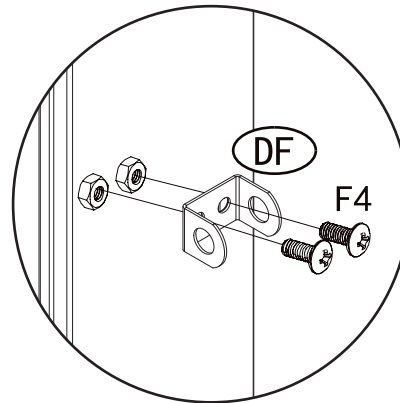
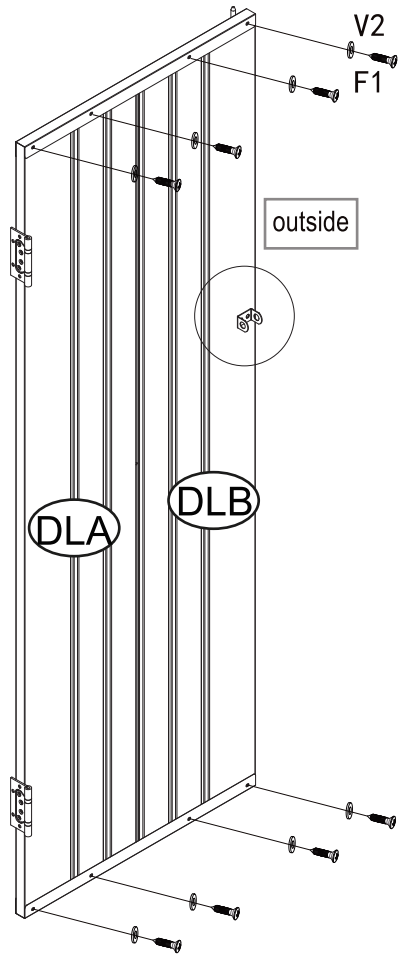

STEP 35

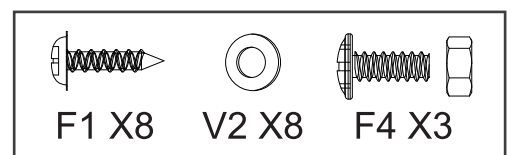
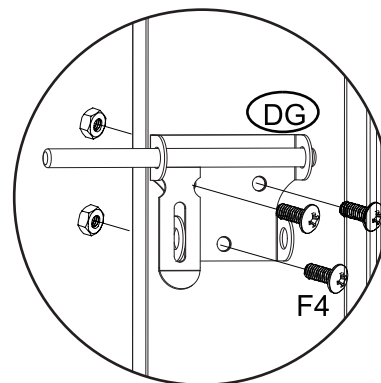
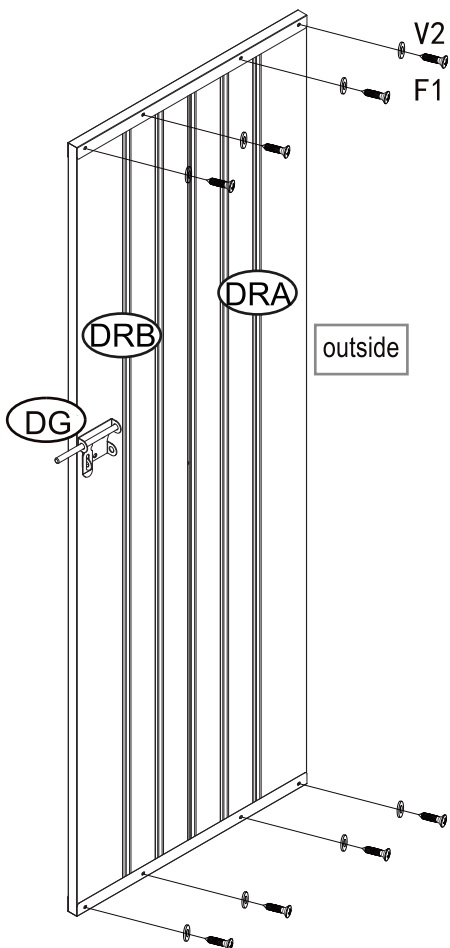

STEP 36

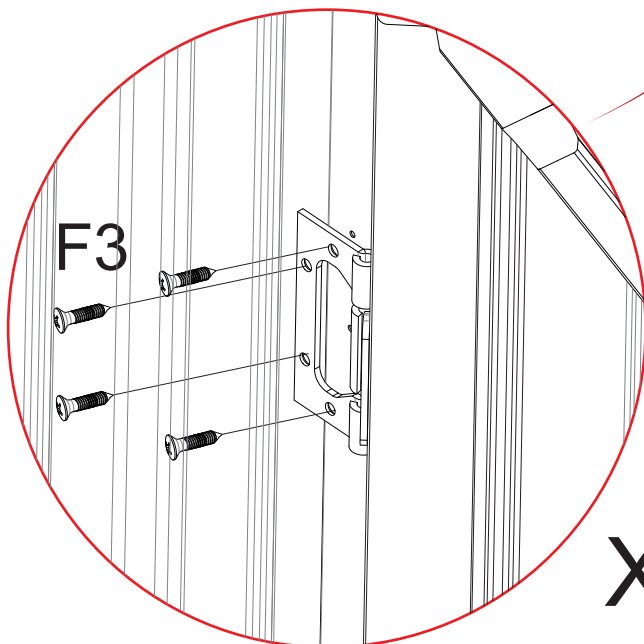
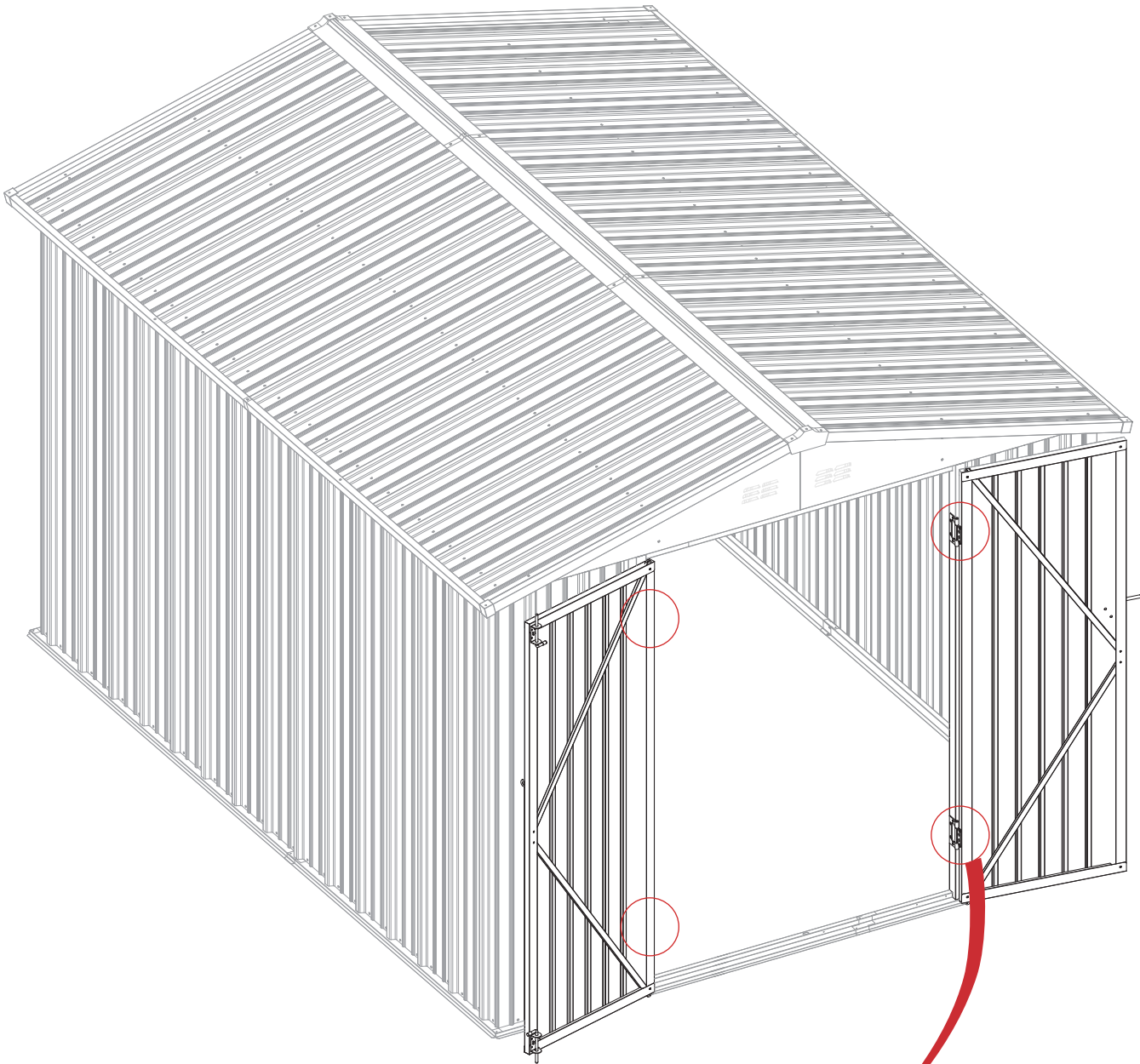

X4

29

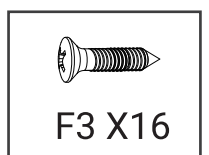

STEP 37

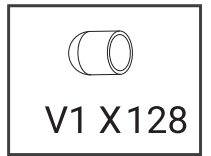
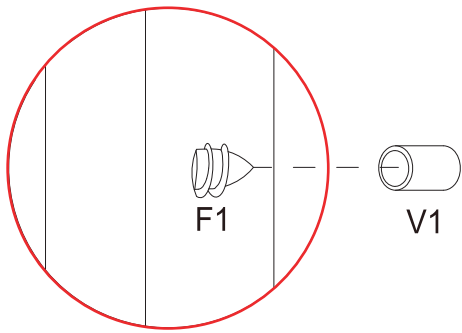
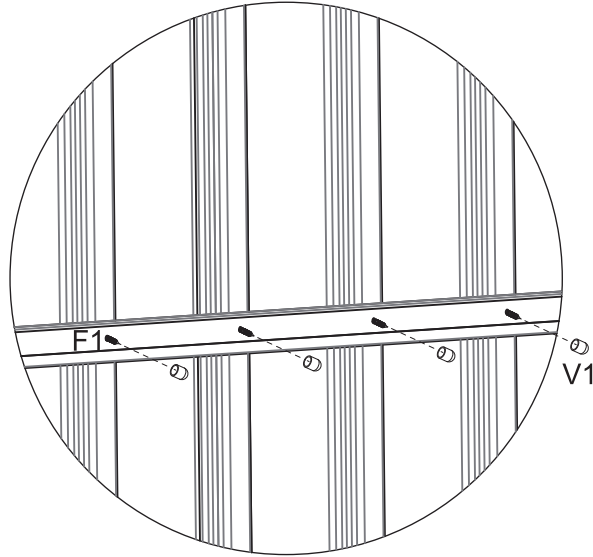

FINISH

