



CARTRIDGE FILTER WITH BUILT-IN PUMP

ITEM #75204



OWNER'S MANUAL AND SAFETY INSTRUCTIONS

SAVE THIS MANUAL: KEEP THIS MANUAL FOR SAFETY WARNINGS, PRECAUTIONS, ASSEMBLY, OPERATING, INSPECTION, MAINTENANCE AND CLEANING PROCEDURES. WRITE THE PRODUCT'S SERIAL NUMBER ON THE BACK OF THE MANUAL NEAR THE ASSEMBLY DIAGRAM (OR MONTH AND YEAR OF PURCHASE IF PRODUCT HAS NO NUMBER).

FOR QUESTIONS PLEASE CALL OUR CUSTOMER SUPPORT: (909) 628 0880 MON-FRI 9AM TO 3PM PST

WARNING

GENERAL SAFETY WARNINGS

Read all safety warnings and instructions. Failure to follow the warnings and instructions may result in electric shock, fire and/or serious injury. Save all warnings and instructions for future reference.

The warnings, precautions, and instructions discussed in this instruction manual cannot cover all possible conditions and situations that may occur. It must be understood by the operator that common sense and caution are factors which cannot be built into this product, but must be supplied by the operator. Read carefully and understand all **ASSEMBLY AND OPERATION INSTRUCTIONS** before operating. Failure to follow the safety rules and other basic safety precautions may result in serious personal injury.

- **WARNING -TO REDUCE THE RISK OF INJURY, do not permit children to use this product unless they are closely supervised at all times.**
- **CAUTION - To reduce the risk of electric shock the pool must be installed no closer than 6 feet (1.8 m) from any electrical outlet. Do not place portable appliances closer than 5 feet (1.5 m) from the pool.**
- **DO NOT BURY CORD.** Locate cord to minimize abuse from lawn mowers, hedge trimmers, and other equipment.
- **WARNING-To reduce the risk of electric shock, replace damaged cord immediately.**
- **WARNING-To reduce the risk of electric shock, do not use extension cord to connect unit to electric supply; provide a properly located outlet.**
- **CAUTION: This pump is for use with storable pools only. Do not use with permanently-installed pools. A storable pool is constructed so that it is capable of being readily disassembled for storage and reassembled to its original integrity. A permanently-installed pool is constructed in or on the ground or in a building such that it cannot be readily disassembled for storage. Please examine and verify all sand filter components are present before use. Notify XTREMEPOWERUS at the customer service number listed on this manual for any damaged or missing parts at the time of purchase.**
- **FOR USE WITH SWIMMING POOLS ONLY.**
- **CAUTION: TO ENSURE CONTINUED PROTECTION AGAINST SHOCK HAZARD, USE ONLY IDENTICAL REPLACEMENT PARTS WHEN SERVICING.**
- **WARNING: RISK OF ELECTRIC SHOCK. CONNECT ONLY TO A GROUNDING TYPE RECEPTACLE.**
- **CAUTION: FOR CONTINUED PROTECTION AGAINST POSSIBLE ELECTRIC SHOCK THIS UNIT IS TO BE MOUNTED TO THE BASE IN ACCORDANCE WITH THE INSTALLATION.**
- **1) Connect Only To Properly Grounded Outlet. Do Not Remove Ground Pin.**
- **2) Inspect Cord Before Using – Do Not Use If Cord Is Damaged.**
- **3) Do Not Touch Plug With Wet Hands**
- **4) Double Insulated – When Servicing Use Only Identical Replacement Parts.**



SAVE THESE WARNINGS

PRODUCT INFORMATION

1	49111701	Adaptor
2	5024002000	Pressure gauge
3	88601004	Drain plug with gasket
4	47312001	Seal cover
5	5022001000	O-ring
6	47311009	Locking ring
7	647312471000	Cartridge element
8	47311009	Locking ring latch
9	647312471000	Main body
10	5431081080	O-ring
11	47312408	Cover
12	5212007000	O-ring
13	47312402	Basket
14	5212032000	Screw (st4.2*16)
15	47312406	Bottom cover
16	5431163080	Screw (st5.5*18)
17	41044001	Pump base
18	5212002000	O-ring
19	5028013000	Clamp
20	5212002000	Screw (st3.5*12)
21	5028013000	Seal assembly
22	647271271000	Impeller
23	547251271000	Pump body
24	47312407	Motor

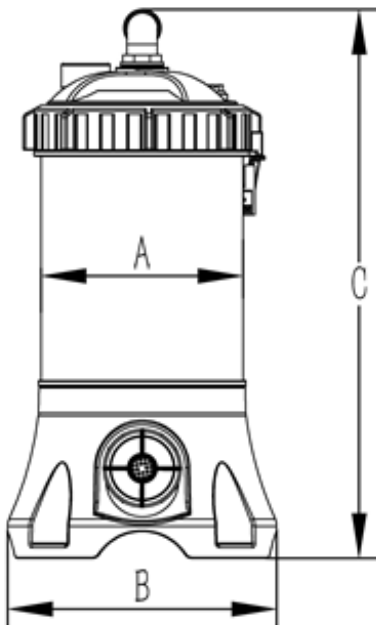
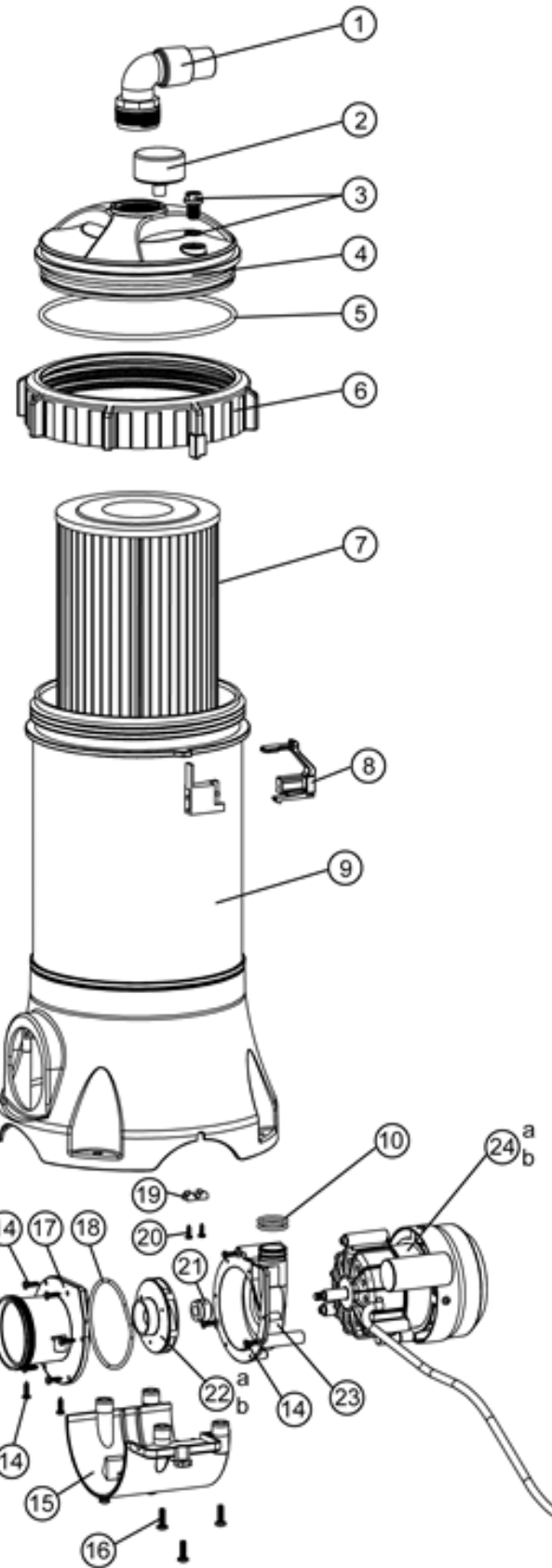

Effective filtration area	25 FT ²
Design-flow rate	25 GPM
Maximum working pressure	3.45 Bar / 50PSI
Net. Weight	22lbs
Power	0.25HP
Dimension	A. 17.64 inches
	B. 23.62 Inches
	C. 47.64 Inches

INSTALLATION

FILTER LOCATION

It is important to first determine where your pump and filter will be located. If above the water line, a self-priming pump must be used. Self-priming pumps have the ability to lift water from a lower level and prime automatically.

1. Since plumbing fittings offer a resistance to water flow, position the filter as close to the swimming pool as local codes allow. Keep the number of fittings to a minimum. Select a well drained area, one that will not flood when it rains.
2. Set the filter on a solid, level surface. Be sure filter, pump, drain and pressure gauge are accessible for convenient operation.
3. Position the filter so the tank can drain by gravity.
4. If practical, place pump and filter in the shade to shield it from continuous, direct heat from the sun.

PLUMBING

1. Use 1-1/2" or 2" piping. When making permanent connections, be sure to provide unions for easy servicing.
2. Refer to the diagrams for basic suggested valving. Ball valves are recommended where needed. While all systems vary, the main consideration is to provide the desired control of water flow from the pool to the pump and filter, and back to the pool. When the filter is located below water level, provide valves to prevent back flow of water to the filter during cleaning and routine servicing.
3. All plumbing on the Star-Clear Plus filter are 1-1/2" or 2" N.P.T. or socket (solvent weld). When making threaded connections to the filter use plastic adapters. Apply three turns of Teflon tape (or use special plastic pipe sealant) to male threads. Screw the fitting into the thread hand tight; then using a wrench, tighten one more full turn. Additional tightening is unnecessary.
4. Install pre-filter, o-ring and clear cover on the inlet as below illustration.
5. Connect the pool suction plumbing between the skimmer, pool outlet, etc. and the pump.
6. Install the pool return plumbing.
7. If pressure gauge is not installed, apply Teflon tape to the gauge threads, and carefully screw the gauge into the threaded hole in the filter head.
8. A manual air relief valve is furnished to aid in bleeding off unwanted air when starting the filter. The auto air relief provides air removal during operation.
9. All electrical connections should be made in accordance with local codes.
10. Check for joint leaks before operating.
11. Refer to pump instruction booklet for pump information.

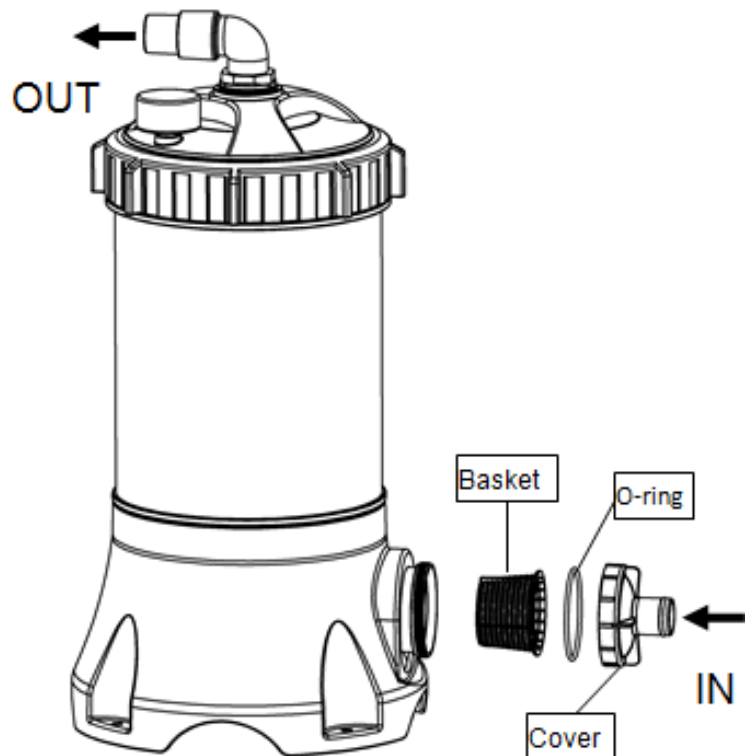

OPERATION

STARTING THE FILTER

Be sure Locking ring is secure (hand tighten--only slight pressure is required).

1. Open manual air relief valve a few turns
2. All suction and discharge valves must be open when starting the system. Failure to do so could cause severe personal injury and/or property damage.
3. Stand clear of the filter and prime and start the pump, following the manufacturer's instructions. Air trapped in the system will automatically vent to the pool and out air relief valve. Close air relief valve as soon as air is vented.
4. Check if the water is running and return to pool, and check the reading of pressure gauge.

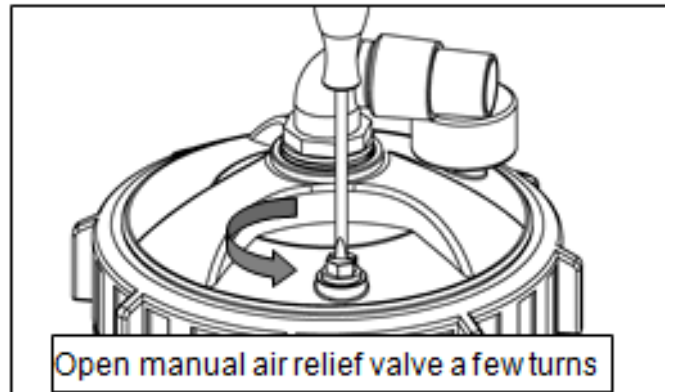
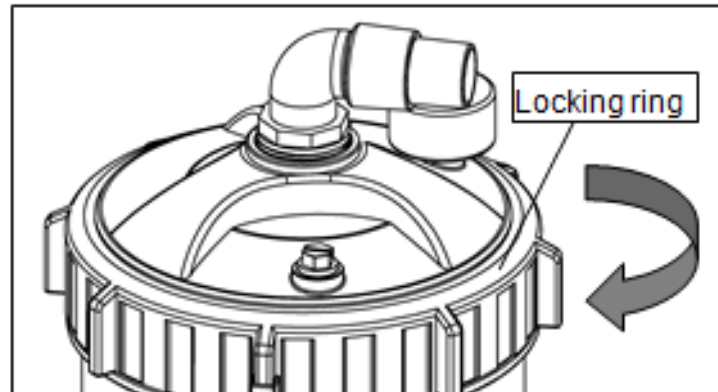

FILTERING

Filtration starts as soon as flow is steady through the filter. As the filter cartridge removes dirt from the pool water, the accumulated dirt causes a resistance to flow. As a result, the gauge pressure will rise and the flow will decrease. When the pressure rises 7-10 psi (.49-.70 Bar) above the starting pressure, or when flow decreases below desired rate, clean or replace the filter cartridge.



CLEAN/REPLACE CARTRIDGE

1. Turn off all system circulation pumps and all electric power on the equipment pad.
2. Set all system valves in a position to prevent water flow to the filter.
3. Unfasten the clamp on the inlet, take off the hose, drain the water.

(Note: To assist draining process: open air vent a few turns.)

4. Unscrew and remove locking ring (counterclock wise direction).
5. Carefully lift off top cover to gain access to filter cartridge.
6. Lift out cartridge and clean. Or, replace with clean, spare cartridge. (See Cleaning Cartridge.)

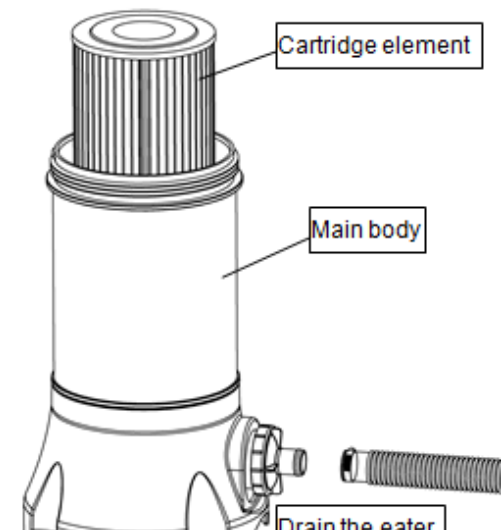
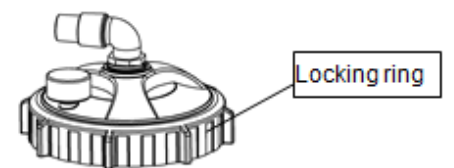

OPERATION / TROUBLESHOOTING

CLEANING CARTRIDGE

The cartridge filter element can be cleaned by pressure washing inside and out with a garden hose. (The cartridge is easier to clean when dry.) After hosing the cartridge, for best results, allow cartridge to dry and carefully brush pleated surface areas to remove fine particles.

Algae, suntan oil and body oils can form a coating on the cartridge pleats which may not be thoroughly removed by hosing. To remove such materials, soak the cartridge in a solution of filter element cleaner (various brands available at pool dealer). Follow manufacturer's directions for use and allow an hour for soaking. Hose thoroughly before reinstalling in filter.

If calcium or mineral deposits are excessive, the cartridge may be restored to "like new" condition by soaking in muriatic acid. Use commercially available 20% muriatic acid added to water in 1 to 1 ratio. Use a plastic container and take extreme care when handling cleaning agents as they can be harmful to eyes, skin and clothing. After cleaning, flush with water.

A spare cartridge filter element is an excellent investment. It provides convenience and ensures that your filter will always be ready to operate at peak efficiency.

RE-INSTALLATION

1. Clean any collected debris from the bottom of filter body.
2. Carefully replace cartridge element over tie rod and into filter body ensuring that the cartridge sits evenly on the collector hub in bottom of filter body.
3. Tighten locking ring in clockwise direction. (Hand tight only.)
4. Connect the hose to inlet and fasten the clamp.
5. Proceed as in STARTING THE FILTER.

WINTERIZING THE FILTER

In areas where sub-freezing temperatures can be expected, the filter should be drained and/or removed from its operating location and stored indoors. Remove and clean cartridge. Reinstall cartridge in filter tank. Tighten locking knob only a few turns when storing

TROUBLESHOOTING

Pump not running	Power cord not properly plugged or loose * Power button not on * Breaker tripping, electric leakage on power button	* Remove the stopper plugs and insert the debris screens * Clean the strainer * Call for service
No water flow	* Stopper plugs were not removed * The strainer was blocked * Filter broken	* Cleaning filter balls * Replace the pressure gauge
Excessive filter pressure	* Dirty filter * The pressure gauge was broken	* Replace the O-ring * Tighten them
Pool water not clear	O-ring on the hose connection was broken - Loose Hoses - Filter not running for enough time - Filter ball element is dirt or broken	* Replace the O-ring * Tighten them * Run the filter for a longer time * Clean / replace filter ball element

PLEASE READ THE FOLLOWING CAREFULLY

THE MANUFACTURER AND/OR DISTRIBUTOR HAS PROVIDED THE PARTS LIST AND ASSEMBLY DIAGRAM IN THIS MANUAL AS A REFERENCE TOOL ONLY. NEITHER THE MANUFACTURER OR DISTRIBUTOR MAKES ANY REPRESENTATION OR WARRANTY OF ANY KIND TO THE BUYER THAT HE OR SHE IS QUALIFIED TO MAKE ANY REPAIRS TO THE PRODUCT, OR THAT HE OR SHE IS QUALIFIED TO REPLACE ANY PARTS OF THE PRODUCT. IN FACT, THE MANUFACTURER AND/OR DISTRIBUTOR EXPRESSLY STATES THAT ALL REPAIRS AND PARTS REPLACEMENTS SHOULD BE UNDERTAKEN BY CERTIFIED AND LICENSED TECHNICIANS, AND NOT BY THE BUYER. THE BUYER ASSUMES ALL RISK AND LIABILITY ARISING OUT OF HIS OR HER REPAIRS TO THE ORIGINAL PRODUCT OR REPLACEMENT PARTS THERETO, OR ARISING OUT OF HIS OR HER INSTALLATION OF REPLACEMENT PARTS THERETO.

Record Product's Serial Number Here: _____

Note: If product has no serial number, record month and year of purchase instead.

Note: Some parts are listed and shown for illustration purposes only and are not available individually as replacement parts.



SAVE THESE INSTRUCTIONS.

Questions, issues or missing parts?

Before returning the item, our exceptional customer service is here to help.



Call us: 909.628.0880

Email Us: customer@xtremepowerusa.com

Hours of operation: 9am - 4pm Monday through Friday

PRODUCT MADE IN CHINA