

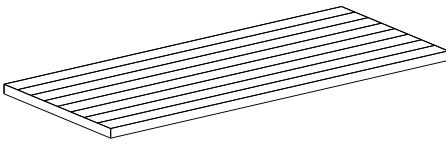

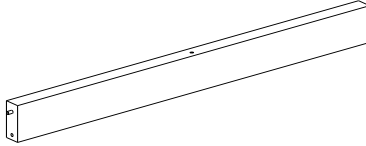
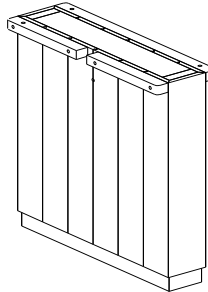
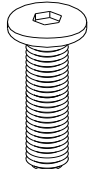
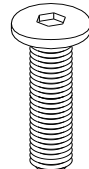

ASSEMBLY INSTRUCTIONS

SKU# 51031648/51031649

PARTS LIST

A	TABLE TOP X 1		<p>Before beginning</p> <ol style="list-style-type: none"> 1 - Carefully unpack and position the item on a clean, non-marring surface to assemble. 2 - Read this Assembly Instructions from beginning to end before starting to assemble. 3 - Take an inventory of the required parts to ensure all are available. 4 - To prevent accidental choking hazards, keep all packing materials away from small children. 5 - Only tighten hardware until ALL hardware are fully engaged on their locations. Overtighten bolts will damage the bolt threads. 6 - Use only factory provided hardware to assemble. Unapproved hardware can damage product or jeopardize the structural integrity of the product. 7 - The use of power tool to assemble is not recommended due to high risk of over-torque, which can damage the product.
B	TOP SUPPORT x1		
C	LEGS X 2		

Z	HARDWARE	Z1	Z2	Z3	Z4	Z5	Z6		
									
		8X150 MM X 1	8X60MM X 10	8X19X2MM X 11	8X12X2MM X 11	4X59MM X 1	X4 Adjustable Floor Glide (Pre-installed at the bottom of the legs)		

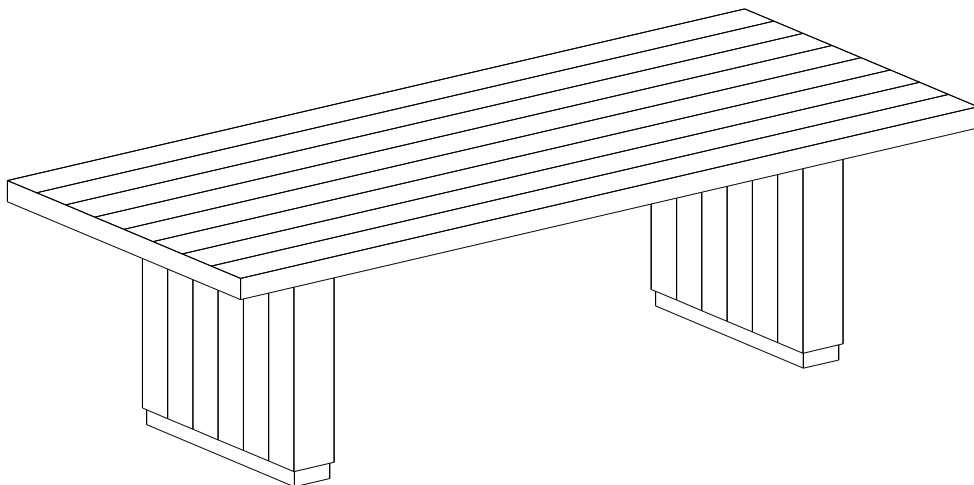

 <p>ASSEMBLY REQUIRES TWO PEOPLE</p>	 <p>15-MINUTE ASSEMBLY TIME</p>	 <p>KEEP INSTRUCTIONS FOR FUTURE USE</p>		
--	--	---	---	--

ASSEMBLY INSTRUCTIONS
SKU# 51031648/51031649

1

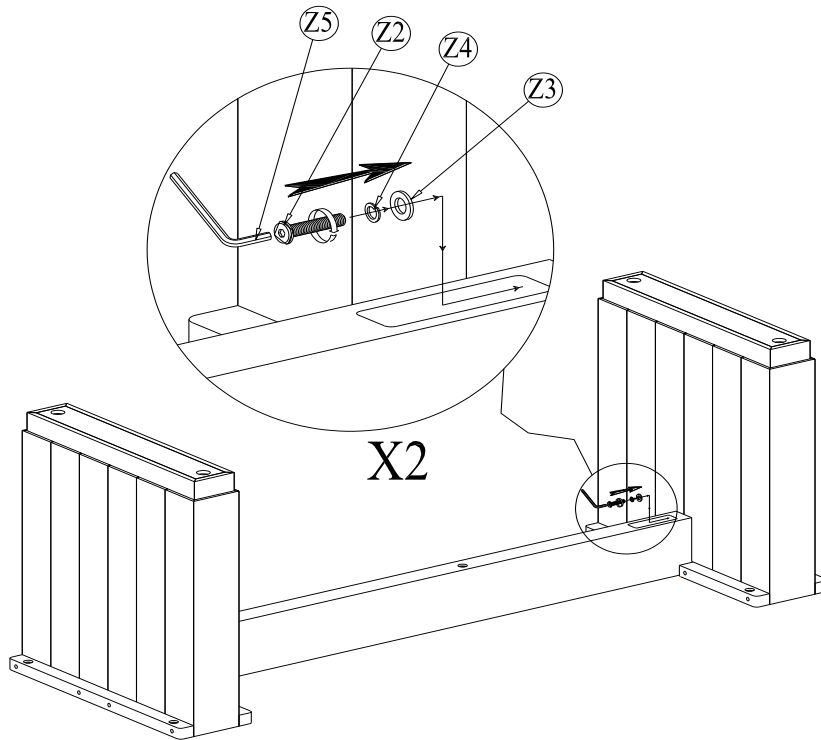

- Assemble the Top Support (B) to the Legs (C), using Allen key (Z5) to tighten Allen Bolts (Z2), Spring Washers (Z4) and Washers (Z3).

2

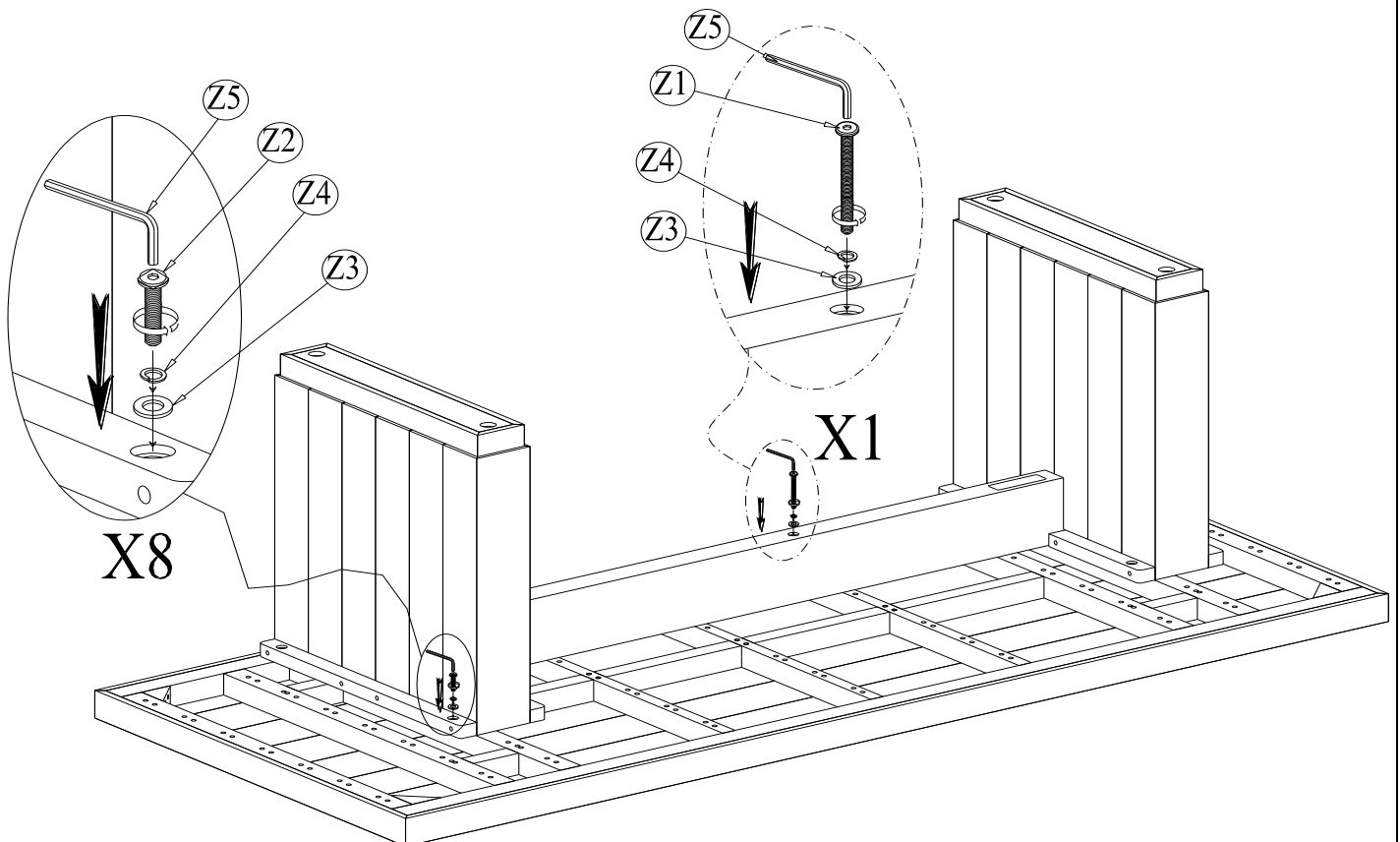

- Attach the Leg set into the Table Top (A).
- Using Allen key (Z5) to tighten Allen Bolts (Z1), Allen Bolts (Z2), Spring washers (Z4) and Washers (Z3)

ASSEMBLY INSTRUCTIONS
SKU# 51031648/51031649

3

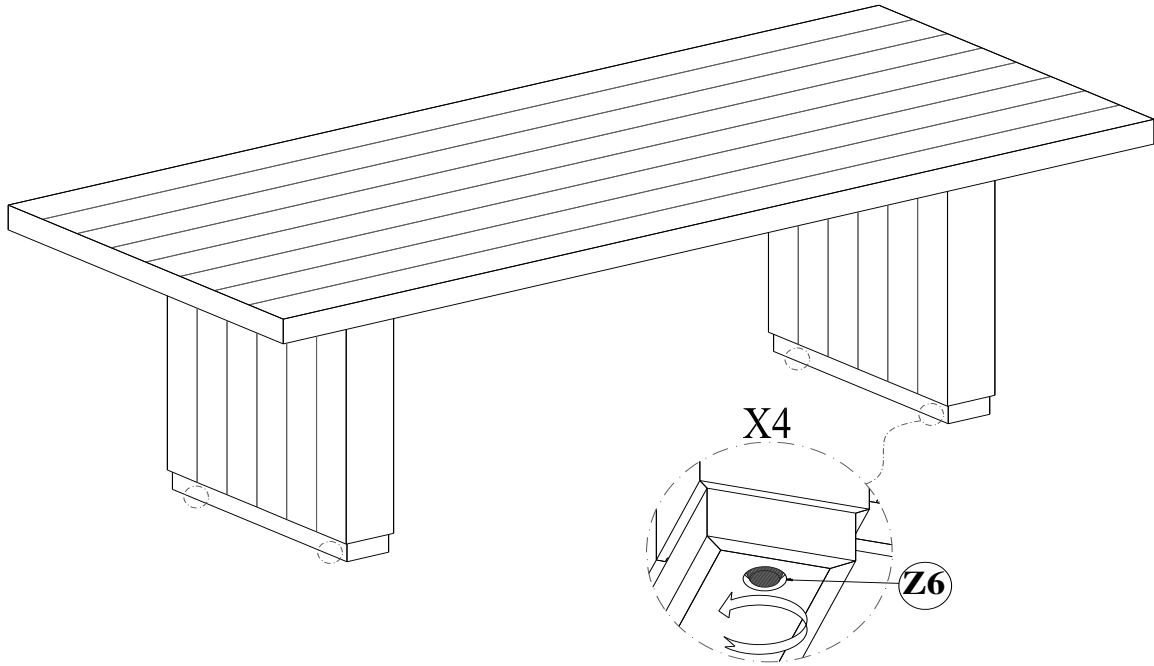

- With the assistance of two people, carefully flip the table over and position it on its legs.
- If the table is not level, make adjustments by using the adjustable floor glides beneath the legs.
- Assembly Completed