

Outdoor Sofa

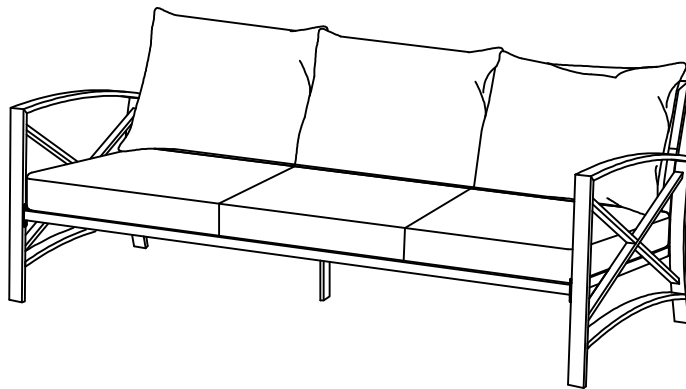

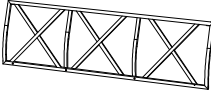
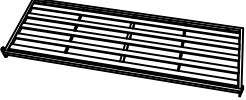
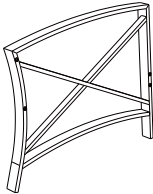
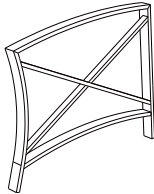
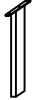
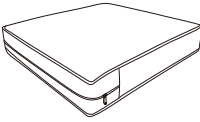
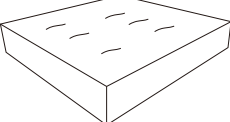
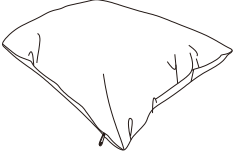
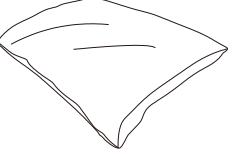

PART LIST

| | | | | |
|---|---|---|---|---|
|  |  |  |  |  |
| <p>Back Panel 1 PC</p> | <p>Seat Panel 1 PC</p> | <p>Right Arm Panel 1 PC</p> | <p>Left Arm Panel 1 PC</p> | <p>Leg 1 PC</p> |
|  |  |  |  | |
| <p>Cover of Seat Cushion * 3 PCS</p> | <p>Core of Seat Cushion 3 PCS</p> | <p>Cover of Back Cushion * 3 PCS</p> | <p>Core of Back Cushion 3 PCS</p> | |

*Please note cushion covers will ship separately.

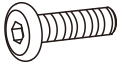
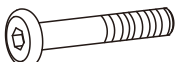
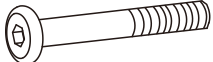
HARDWARE LIST

| | | | | |
|---|---|---|---|---|
|  |  |  |  |  |
| <p>#1 M6*15mm Short Bolt 6 PCS (Extra 1)</p> | <p>#2 M6*25mm Medium Bolt 4 PCS (Extra 1)</p> | <p>#3 M6*40mm Long Bolt 4 PCS (Extra 1)</p> | <p>#4 M6mm Flat Washer 14 PCS (Extra 1)</p> | <p>#5 M6mm Allen Wrench 1 PC</p> |

Step 1. Lay left arm panel (part D) down on a soft flat surface, such as carpet, as shown below. Attach back panel (part A) to left arm panel (part D) using long bolts (part #3), flat washers (part #4) and allen wrench (part #5).

NOTE: Please do not fully tighten bolts until unit is fully assembled.

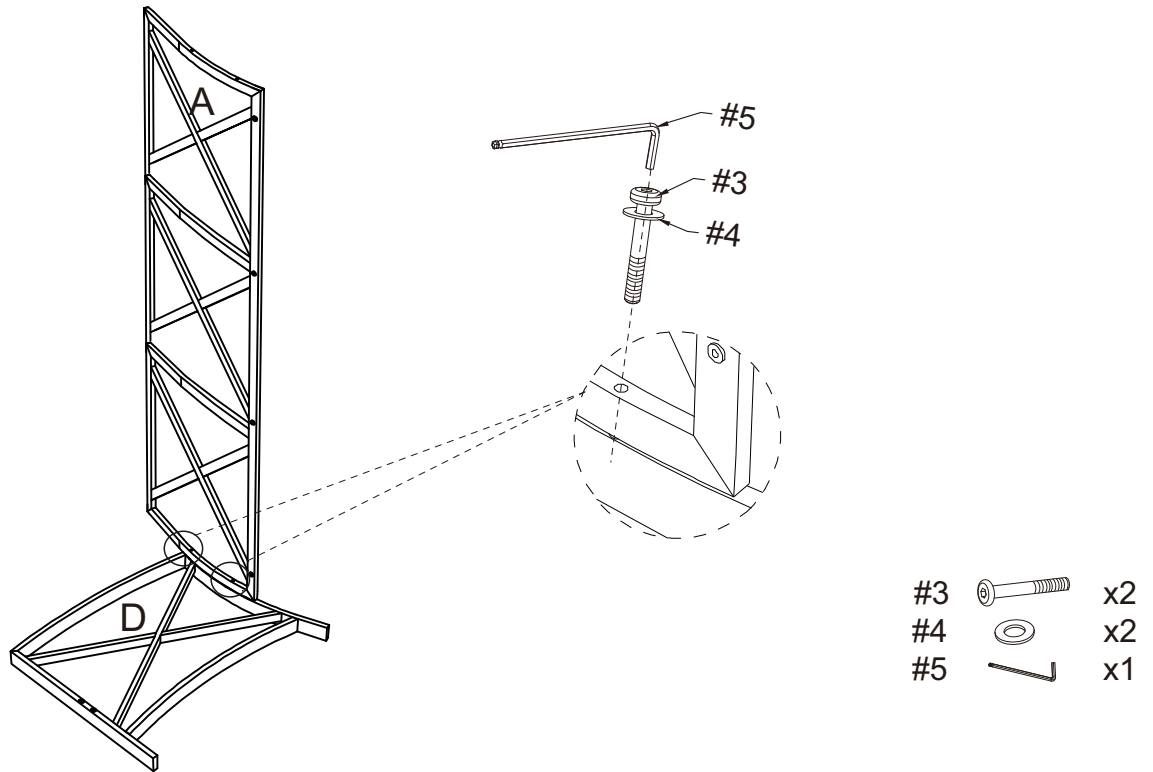

Step 2. Attach seat panel (part B) to assembled unit (parts A & D) using short bolts (part #1), medium bolts (part #2), flat washers (part #4) and allen wrench (part #5).

NOTE: Please do not fully tighten bolts until unit is fully assembled.

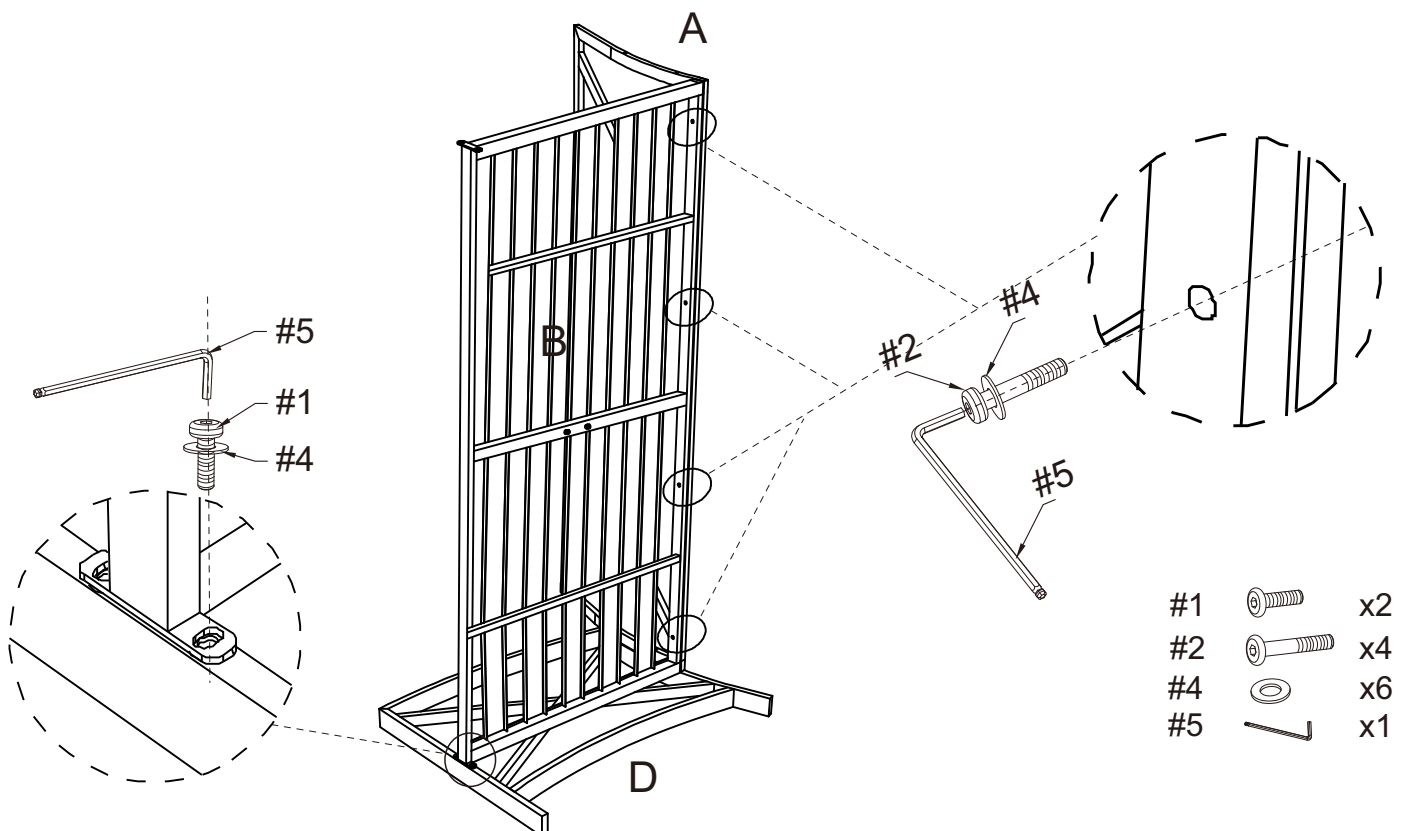

Step 3. Attach right arm panel (part C) to back panel (part A) and seat panel (part B) using short bolts (part #1), long bolts (part #3), flat washers (part #4) and allen wrench (part #5).

NOTE: Please fully tighten all bolts at this time.

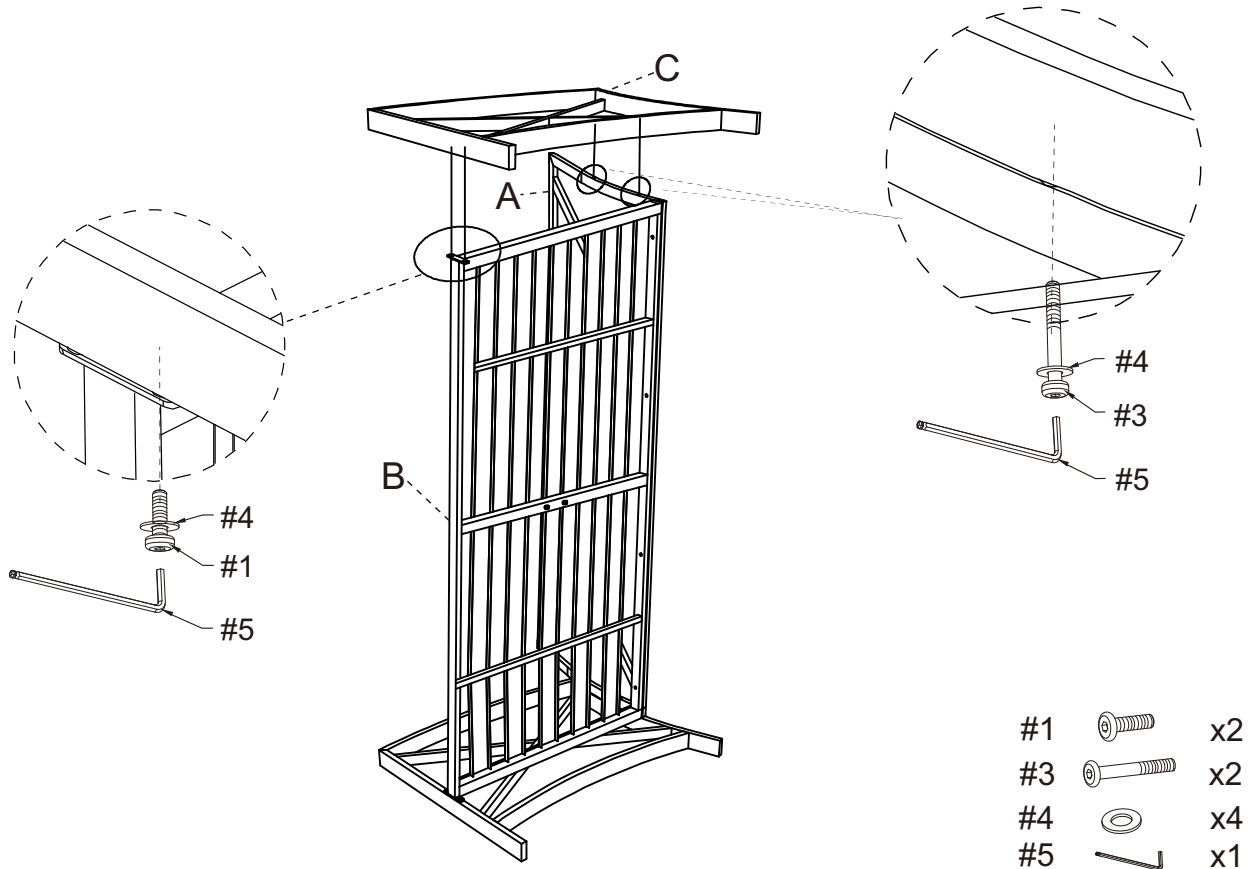

Step 4. Attach leg (part E) to seat panel (part B) using short bolts (part #1), flat washers (part #4) and allen wrench (part #5).

NOTE: Please fully tighten all bolts at this time.

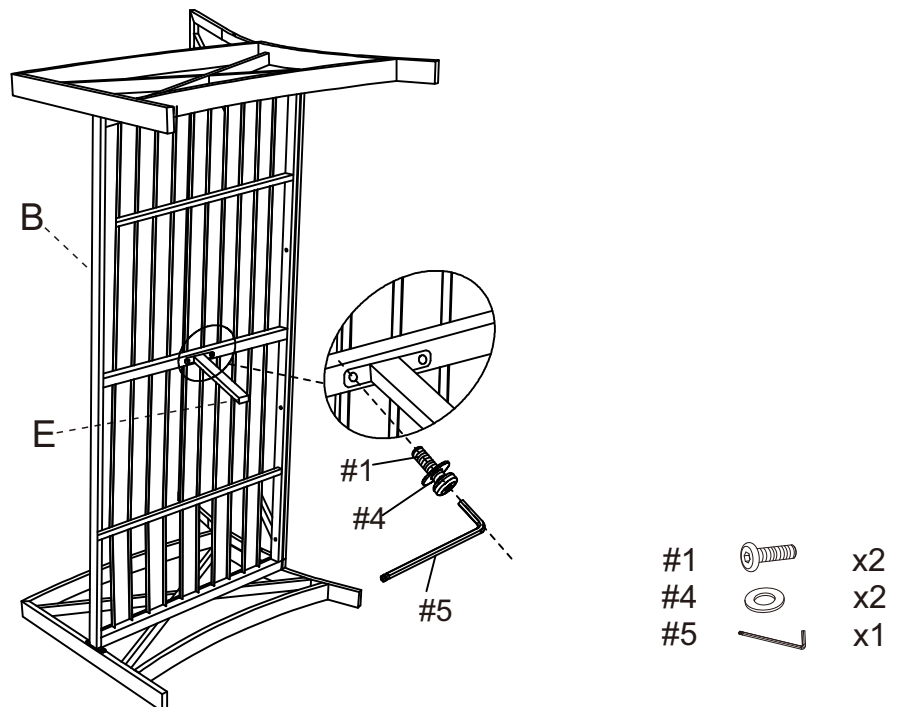

Step 5. Insert core of seat cushions (part G) into cover of seat cushions (part F).
Insert core of back cushions (part I) into cover of back cushions (part H).

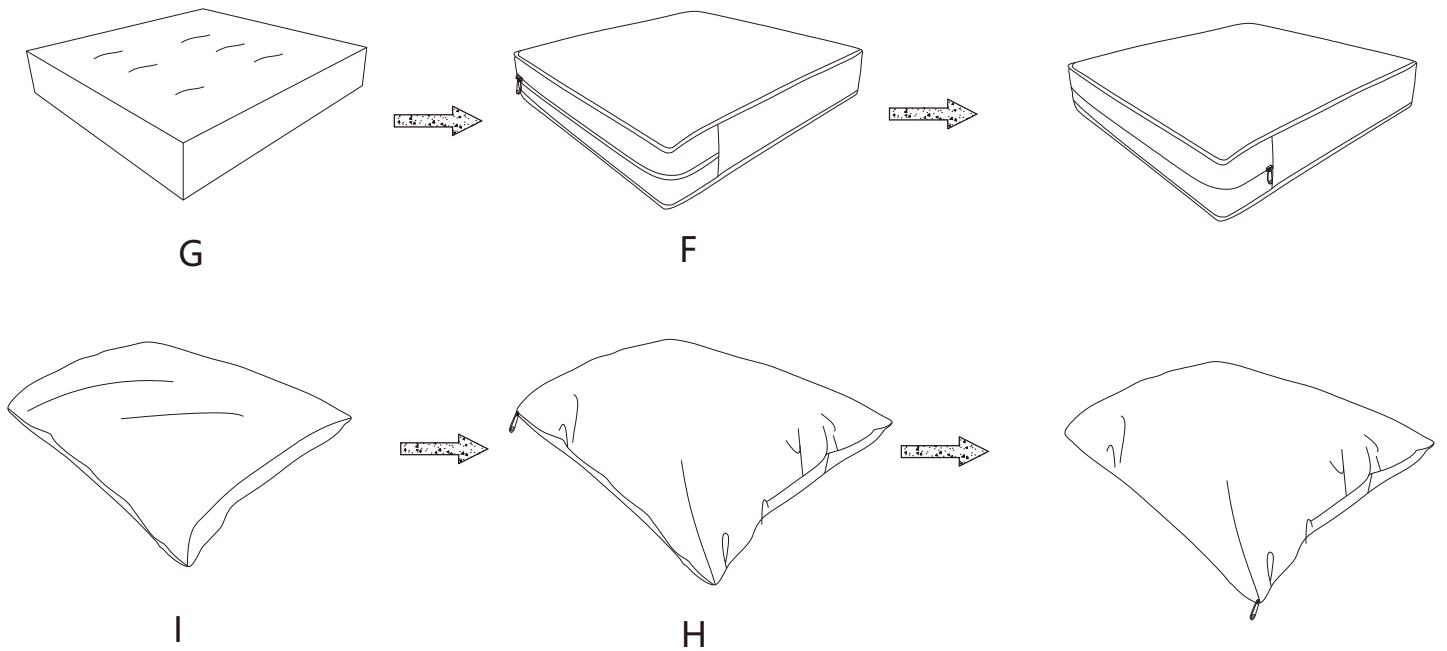

Step 6. Carefully turn unit upright and add cushions as shown below.

