

ASSEMBLY INSTRUCTION

E371-13 54.5"W BENCH BASE

A Side Frame  2pcs	B Middle Frame  1pc	C Top Stretcher  4pcs
D Bottom Stretcher  2pcs	E Cushion (In Other Carton)  1pc	F Bolt 1/4"x1/2"  12pcs
G Bolt 1/4"x1"  8pcs	H Flat Washer 1/4"  8pcs	I Lock Washer 1/4"  8pcs
J Allen Wrench 1/4"  1pc		

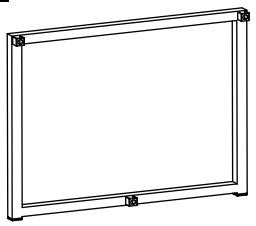
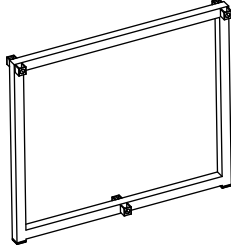
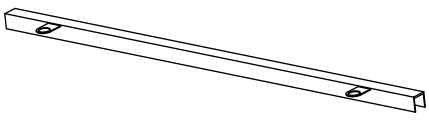
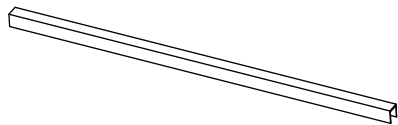
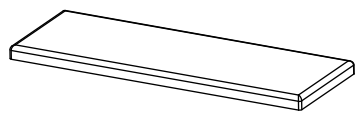
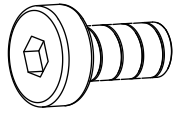
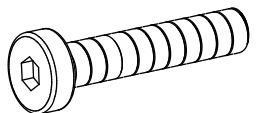
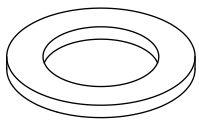
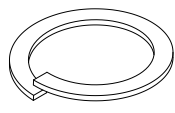
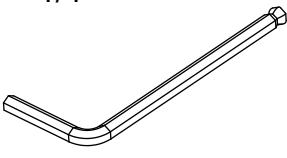
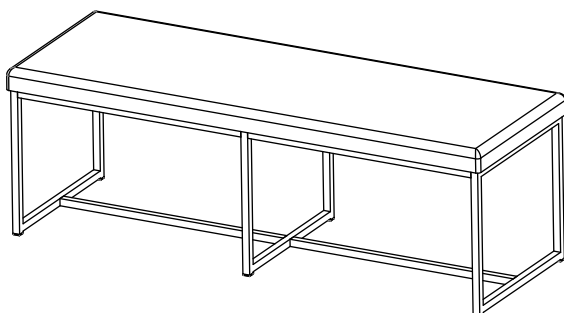

This page lists all the contents included in the box. Please take the time to identify the hardware as well as the individual components to this product. As you unpack and prepare for assembly, place the contents on a carpeted or padded area to protect them from damage.

***** Do not tighten screws & bolts until the entire unit is completely assembled.**

- 1** Attach side frame (A) and middle frame (B) to top stretcher (C) and bottom stretcher (D) by using bolt (F) and allen wrench (J) as shown.

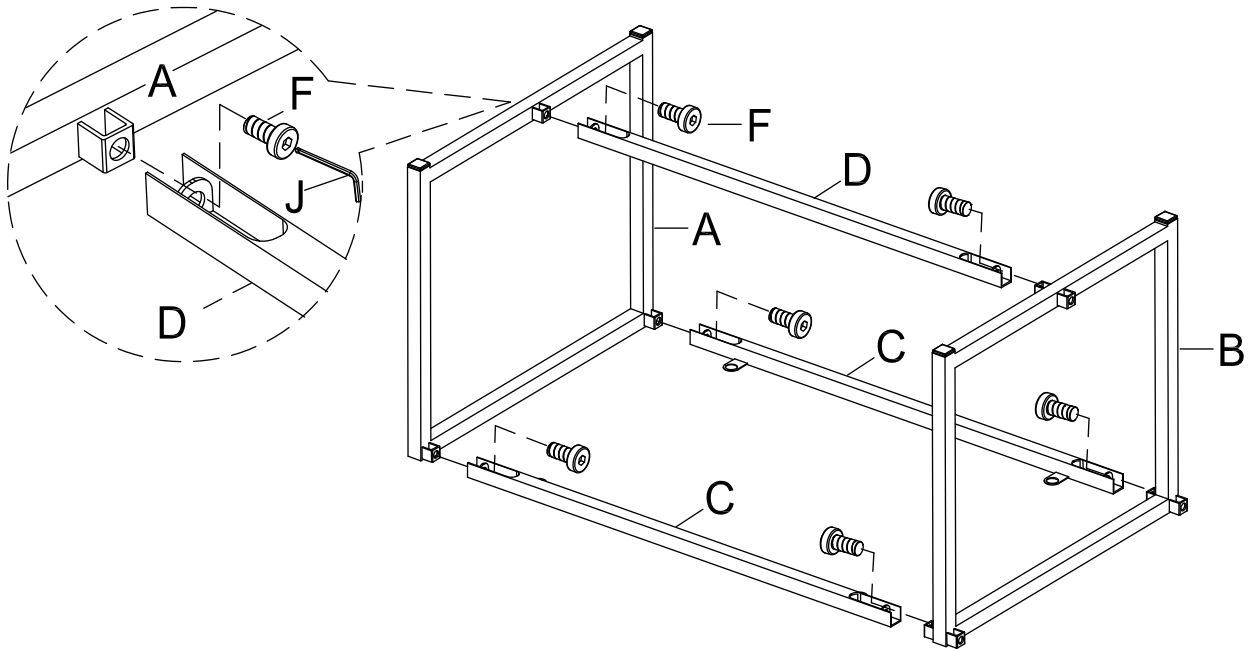

- 2** Attach top stretcher (C) and bottom stretcher (D) to middle frame (B) by using bolt (F) and allen wrench (J). Then use bolt (F) and allen wrench (J) again, attach side frame (A) to top stretcher (C) and bottom stretcher (D) as shown.

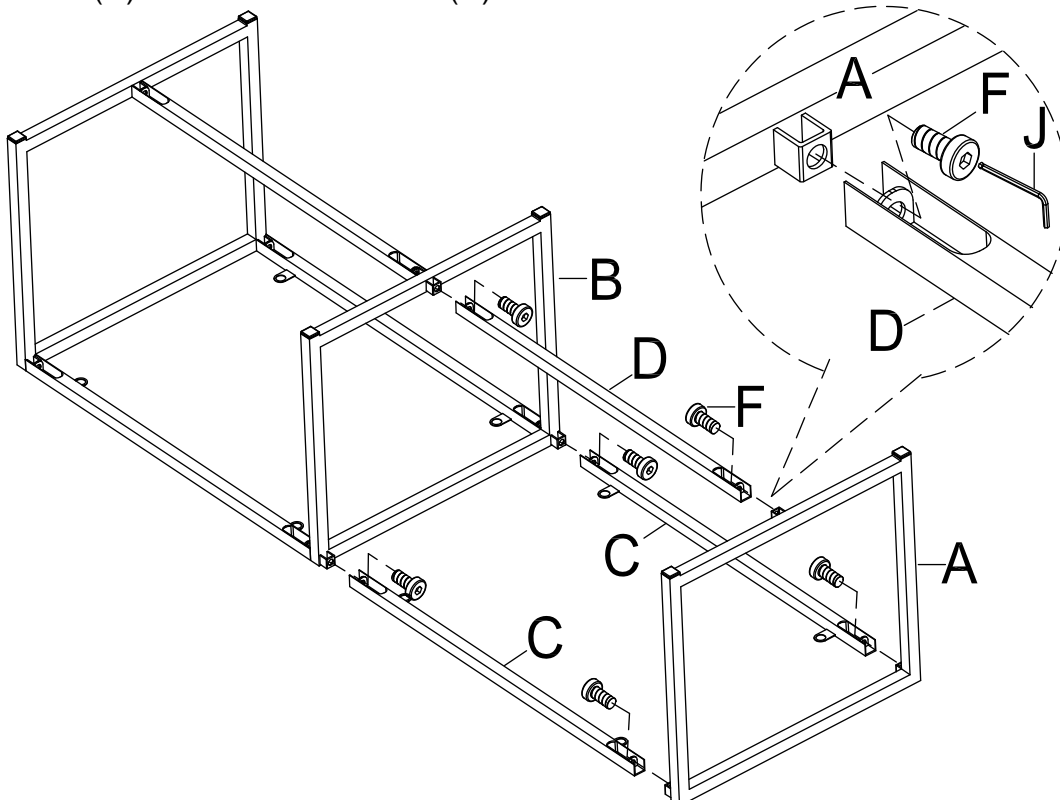

3

Attach assembled metal base to cushion (E) by using bolt (G), lock washer (I), flat washer (H) and allen wrench (J) as shown. Carefully turn the assembled unit upright.

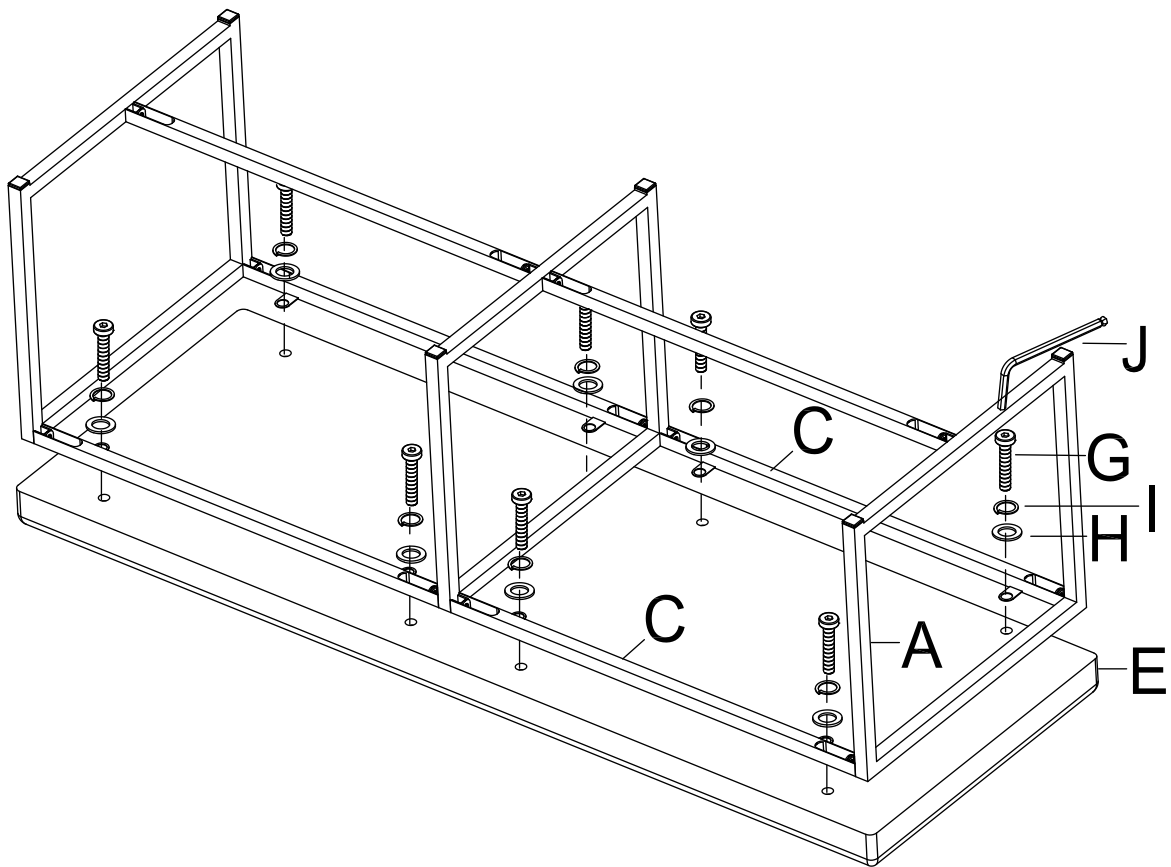

Cleaning & Care

Treat surface with care. Surface is resistant to scratches but is not scratch resistant. Clean surfaces with a dry or damp soft cloth. Do not use abrasive cleaners. Hardware may loosen over time. Periodically check that all connections are tight.