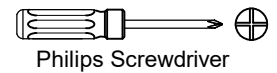

ASSEMBLY INSTRUCTIONS

SAVILLE DINING CHAIR ITEM# 78018

ASSEMBLY
REQUIREMENTS1-Person
Assembly30 Minutes
Assembly Time Per chair
(Approximate)Tools Required
(Not Provided)

Thank you for purchasing our product!

Please refer and use this assembly instruction to assemble the product. Contact our customer service department in case there are any missing or damage parts or hardware. Replacement parts are normally shipped within 2 or 3 days.

**Email : replacementparts@buylateral.com
Within 30 days From delivery date**

PRODUCT PURCHASED THROUGH OUR AUTHORIZED VENDORS ONLY ARE ELIGIBLE FOR REPLACEMENT PARTS

We appreciate your business!

THIS PRODUCT IS FOR INDOOR AND HOUSEHOLD USE ONLY- NOT FOR COMMERCIAL USE.

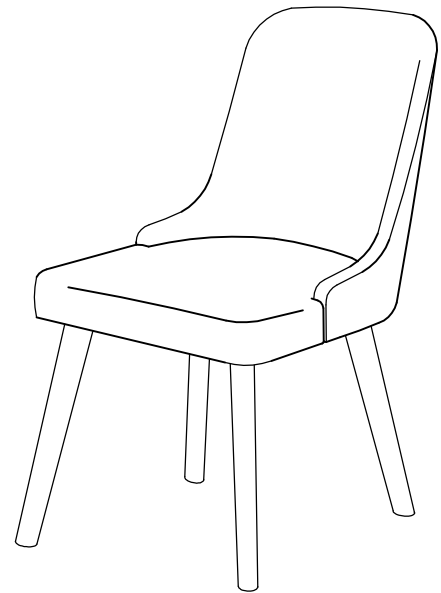

ASSEMBLY PREPARATION

1. Remove all packaging materials, staples and packing straps from the carton.
2. Refer to Parts List and Hardware List and ensure parts and hardware are correct before assembly.
3. Contact customer service for missing parts.
4. Place all wooden parts on a clean, flat and soft surface (e.g. carpet or rug) to prevent parts from getting scratched.

SAFETY PRECAUTION

1. KEEP ALL HARDWARE PARTS OUT OF REACH OF CHILDREN.
2. DISPOSE PLASTIC PACKAGING MATERIAL IMMEDIATELY TO AVOID ANY RISK OF SUFFOCATION TO CHILDREN AND ANIMALS.

TIPS FOR ASSEMBLY

1. Allow ample room for assembly and in close proximity to where product will be placed.
2. Assemble the product on a surface that does not scratch or damage the exterior gloss and finish of the furniture.
3. Identify all of the parts, hardware and quantities required for each step.
4. During assembly, do not over-tighten any fittings as this may cause damage.
5. DO NOT USE POWER TOOLS TO ASSEMBLE THIS PRODUCT.
6. Always place the product on a flat, level surface.
7. Do not sit or stand on the partially assembled product; only use the product for which it is intended.





CARE AND MAINTENANCE

- Wipe clean with a soft , dry cloth; avoid the use of harsh chemicals or household cleaners as they may damage the exterior finish of the furniture.
- Hardware may loosen over time. Periodically , check that all connections are tight ; re-tighten as necessary.
- Solid wood is impacted by heat and humidity fluctuations which may cause in small joint separations or hairline cracks; place the furniture away from direct sunlight and air conditioning vents, heating vents or units to protect the furniture.





ASSEMBLY INSTRUCTIONS

SAVILLE DINING CHAIR ITEM# 78018

PARTS LIST (FOR 2 COMPLETE CHAIR)

Item	Description	Part	Qty
1	Chair Body		2
2	Leg Left		2
3	Leg Right		2
4	Corner Block -Short		4
5	Corner Block -Long		4

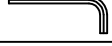
HARDWARE LIST (FOR 2 COMPLETE CHAIR)

Item	Description	Part	Qty	Extra
A	JCBC M6 X 60mm		8	1
B	Spring Washer M6 X 13mm		8	1
C	CSK Screw M4 X 28mm		16	1
D	Allen Key		1	
E	Leg Stud		8	1

* Extra Hardware For Spare Use

STEP 1

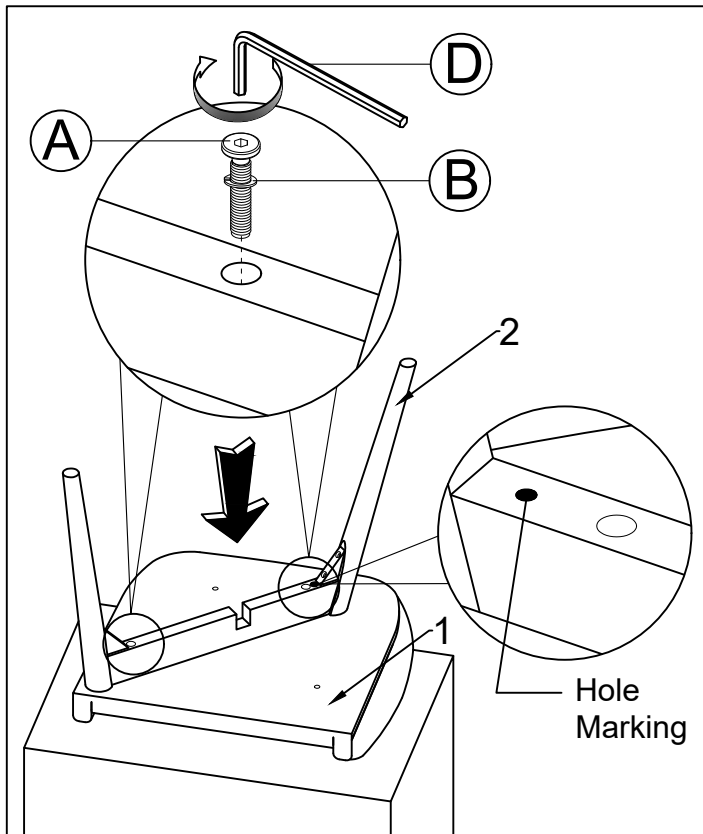

- a) Place Chair Body (1) bottom-side up on an elevated surface (e.g. table top) as shown.
- b) Position Left Leg (2) diagonally and align the screw holes on (2) to the diagonal screw holes on the bottom-side of the seat. (Note: the Hole Marking is towards the rear edge of the seat.)
- c) Insert Screw (A) fitted with Spring Washer (B) into screw hole on (2).
- d) Use Allen Key (D) to drive (A) to fasten (2) to bottom-side of seat. Do not tighten (A) completely until both screws are in place on each leg. Do not over-tighten the screws.

STEP 2

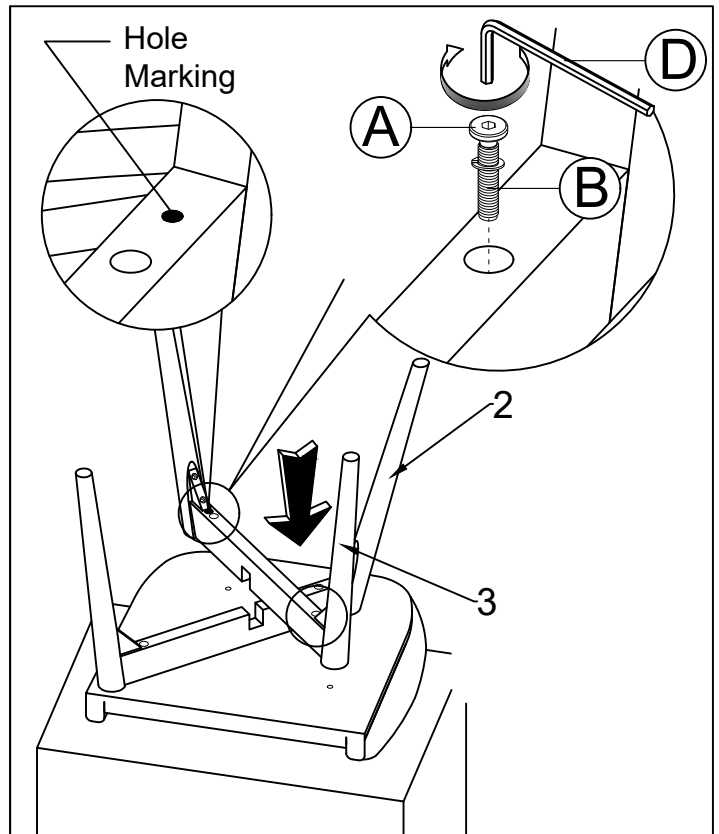

- a) Position Right Leg (3) diagonally to mate its half lap joint to the half lap joint on (2) to form a crossed half lap joint as shown. (Note: the Hole Marking is towards the rear edge of the seat.)
- b) Insert Screw (A) fitted with Spring Washer (B) into screw hole on (3).
- c) Use Allen Key (D) to drive (A) to fasten (3) to bottom-side of seat. Do not tighten (A) completely until both screws are in place on each leg. Do not over-tighten the screws.

ASSEMBLY INSTRUCTIONS

SAVILLE DINING CHAIR ITEM# 78018

STEP 3

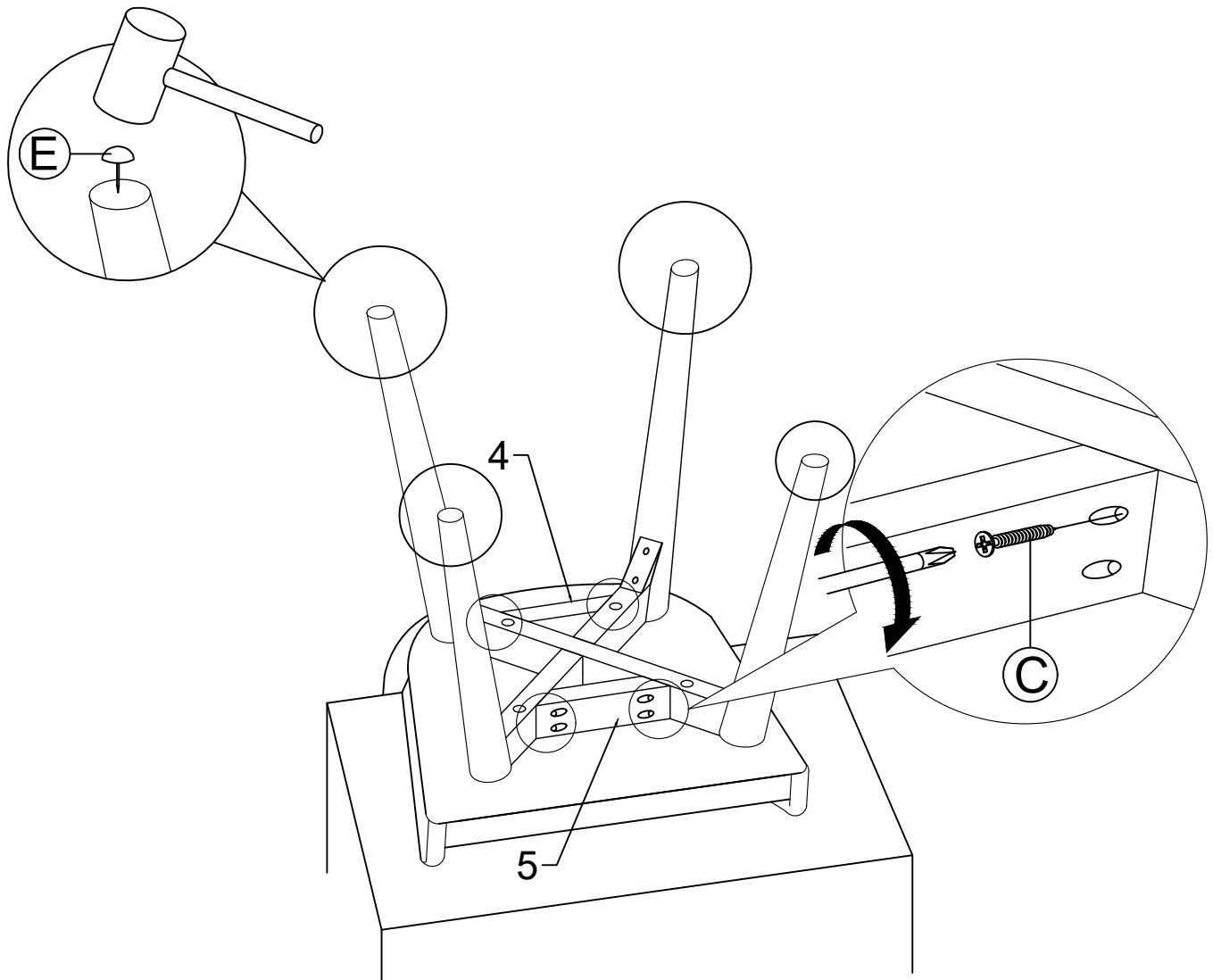

- Fit Corner Block (4 & 5) between and against the Leg Rails of (2 & 3).
- Use a Phillips Screwdriver to drive Screw (C) to fasten (4 & 5) to the Leg Rails of (2 & 3).
Do not tighten the screws completely until both screws are in place on corner block.
Do not over-tighten the screws.
- Use a mallet to gently nail Leg Stud (E) into each end of the leg.

Position the chair right-side up. The assembly of the Chair is complete.